



2Pro Devices

The 2Pro product is an integrated overcurrent/overvoltage protection device. The RoHS-compliant component incorporates PolySwitch PPTC (Polymeric Positive Temperature Coefficient) and metal oxide varistor technology in a single device to help reduce board space requirements and component count.

Damage to telephony communications equipment can be caused by various sources including lightning, electrostatic discharge (ESD), power contact and induction with AC lines. The 2Pro TM2P-10271 devices help provide current limiting during overcurrent events, and voltage clamping during overvoltage events. After a fault condition is removed and power is cycled, 2Pro devices will reset so that the equipment remains operational.

The 2Pro device helps address the need for resettable circuit protection devices for use in cost-sensitive PSTN (Public Switched Telephone Network) and VoIP (Voice over Internet Protocol) telephony equipment. The widespread use of VoIP gateways in homes and enterprise environments as the primary means of voice delivery requires the utmost safety and reliability in equipment. 2Pro circuit protection devices help manufacturers comply with global safety standards, including UL 60950, TIA-968-A, IEC 60950, and ITU-T K.20/K.21. The UL 497A listed protector also helps provide ESD protection.

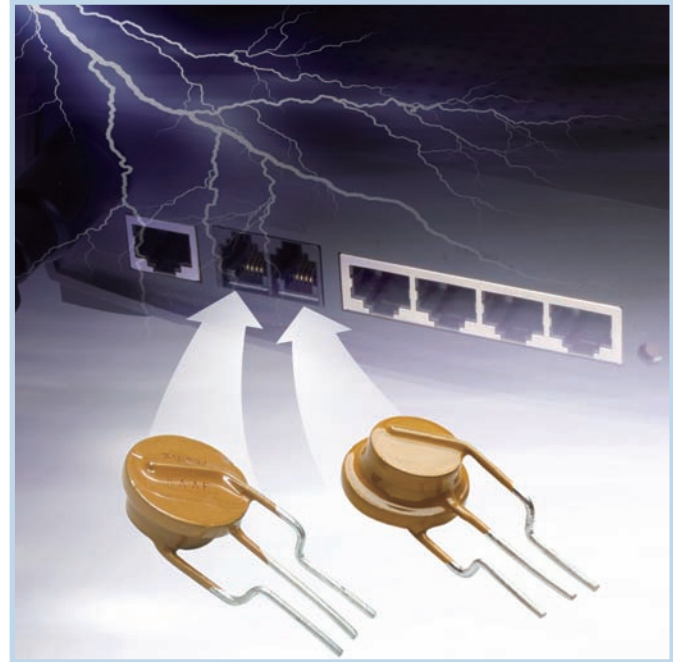

5

Benefits

- Single device helps reduce component count and footprint
- Helps reduce warranty returns
- Helps equipment comply with surge tests per: TIA-968-A, IEC 60950, ITU-T K.20/K.21
- Helps simplify UL 60950 testing
- Helps equipment comply with UL 60950

Features

- Single overcurrent, overvoltage and ESD protection device
- Resettable overcurrent protection
- UL 497A listed protector (#E258475)
- RoHS compliant

Applications

- Cordless telephones
- VoIP gateways
- Fax machines
- Data modems
- Set-top boxes
- Security systems
- MDF modules
- Analog and ISDN linecards

Table 2P1 Electrical Characteristics for 2Pro Devices

Overcurrent (terminals 1 – 2) — Performance ratings @ 20°C

Part Number	I _{HOLD} (A)	I _{TRIP} (A)	Resistance (Ω)			Time to Trip (s)† @ 1A	
			R _{MIN}	R _{MAX}	R _{1MAX} *	Typ.	Max.
TM2P-10271	0.15	0.30	6.5	14.0	16.0	0.9	3

Overvoltage (terminals 2 – 3)

Part Number	Varistor Voltage V @ 1mA		DC Resistance @ 100V (MΩ)	Maximum Clamping Voltage @ 25A (V)	Rated Wattage (W)
	DC(V)	Tolerance			
TM2P-10271	260	+14% -7%	>10	455	0.25

* Maximum device resistance at 20°C measured 1 hour post trip.
 † Corresponds to operation below varistor voltages.

Electrical Schematic

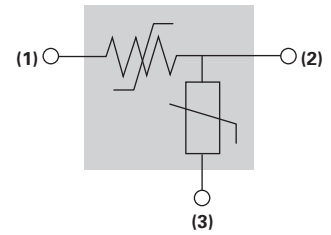

Table 2P2 Dimensions for 2Pro Devices

	A		B		C		D		E	F	
	Min.	Max.	Min.	Max.	Min.	Max.	Min.	Max.	Nom.	Min.	Max.
mm	—	12.0	—	15.0	—	6.6	6.0	—	2.5	—	12.0
inch*	—	(0.47)	—	(0.59)	—	(0.26)	(0.24)	—	(0.10)	—	(0.47)

* The dimensions in inches are rounded approximations.

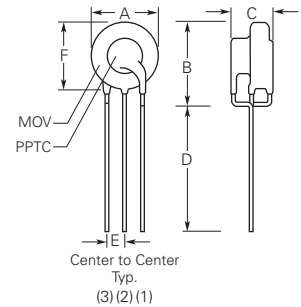

Figure 2P1 Typical Time-to-Trip at 25°C for 2Pro Devices

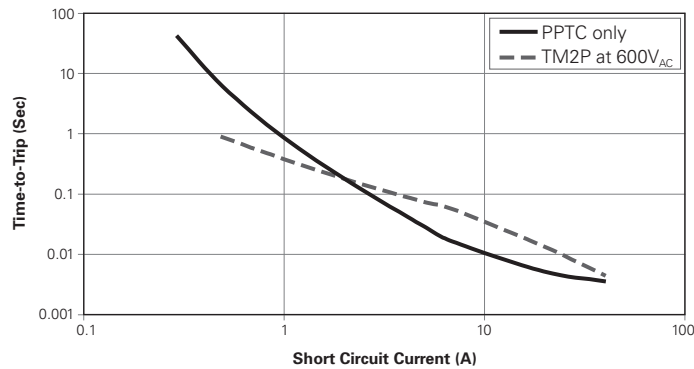

Table 2P3 Physical Characteristics and Environmental Specifications for 2Pro Devices

Physical Characteristics

Lead material	Tin-plated copper, 0.33mm ² (22AWG), ø0.64mm (0.025in.)
Flammability	IEC 695-2-2 needle flame test for 20s
Soldering characteristics	ANSI approved IPC/EIA/JEDEC J-STD-002, Category 3
Solder heat withstand	per IEC-STD 68-2-20, Test Tb, Method1A, Condition B, can withstand 10 seconds at 260°C ± 5°C

Environmental Specifications

Test	Conditions
Passive aging	60°C, 1000 hours / 85°C, 1000 hours
Humidity aging	85°C, 85% RH, 500 hours
Active aging	60°C, 90% RH, 60V _{DC} bias, 1000 hours
Thermal shock	125°C, -55°C (10 times)
Solvent resistance	MIL-STD-202, Method 215K

Note: Storage conditions: 40°C max., 70% RH max., devices should remain in original sealed bag prior to use. Devices may not meet specified values if these storage conditions are exceeded.

Table 2P4 Packaging and Marking Information for 2Pro Devices

Part Number	Bag Quantity	Tape & Reel Quantity	Standard Package	Part Marking	Agency Recognition
TM2P-10271	500	-	10,000	1027 & Batch #	UL 497A/File No. E258475
TM2P-10271-2	-	1,000	5,000	1027 & Batch #	UL 497A/File No. E258475

Table 2P5 Ordering Information for 2Pro Devices

Bulk	500 pieces/bag
	10,000 pieces/box
Tape & Reel	1,000 pieces/reel
	5,000 pieces/box

Wave Soldering and Rework Recommendations for 2Pro Devices
Recommended Wave Soldering for Radial-leaded Devices

- Soldering temperature profile
Temperature characteristic at component terminal with dual wave soldering

Rework

- If a device is removed from the board, it should be discarded and replaced with a new device.

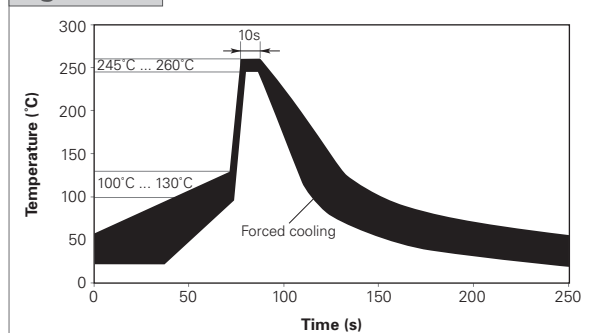
Figure 2P2

Table 2P6 Tape and Reel Specifications for 2Pro Devices (in Millimeters)

2Pro devices are available in tape and reel packaging per EIA 468-B standard. See Figures 2P3 and 2P4 for details.

Description	EIA Mark	IEC Mark	Dimension (mm)	Tolerance
Carrier tape width	W	W	18	-0.5/ +1.0
Hold down tape width	W ₄	W ₀	5	Minimum
Top distance between tape edges	W ₆	W ₂	3	Maximum
Sprocket hole position	W ₅	W ₁	9	-0.5/+0.75
Sprocket hole diameter	D ₀	D ₀	4	±0.2
Abcissa to plane (kinked lead)*	H ₀	H ₀	16	-0.5/0.6
Abcissa to top	H ₁	H ₁	32.2	Maximum
Overall width with lead protrusion	-	C ₁	43.2	Maximum
Overall width without lead protrusion	-	C ₂	42.5	Maximum
Lead protrusion	L ₁	I ₁	1.0	Maximum
Protrusion of cut-out	L	L	11	Maximum
Protrusion beyond hold down tape	I ₂	I ₂	Not specified	-
Sprocket hole pitch	P ₀	P ₀	12.7	±0.3
Pitch tolerance	-	-	20 consecutive	±1
Tape thickness	t	t	0.9	Maximum
Tape thickness with splice*	t ₁	-	2.0	Maximum
Splice sprocket hole alignment	-	-	0	±0.3
Body lateral deviation	Δh	Δh	0	±0.1
Body tape plane deviation	Δp	Δp	0	±1.3
Ordnate to component center lead	P ₂	P ₂	6.35	±0.7
Lead spacing*	F ₁ , F ₂	F ₁ , F ₂	2.54	-0.1/+0.4
Reel width	w ₂	w	56	Maximum
Reel diameter	a	d	370	Maximum
Space between flanges	w ₁	-	51.2	Maximum
Arbor hole diameter	c	f	26	±12.0
Core diameter	n	h	80	Maximum
Box	-	-	56/372/372	Maximum
Consecutive missing pieces*	-	-	3 maximum	-
Empty places per reel*	-	-	Not specified	-

Note: *Differs from EIA specification.

Figure 2P3 EIA Referenced Taped Component Dimensions for 2Pro Devices

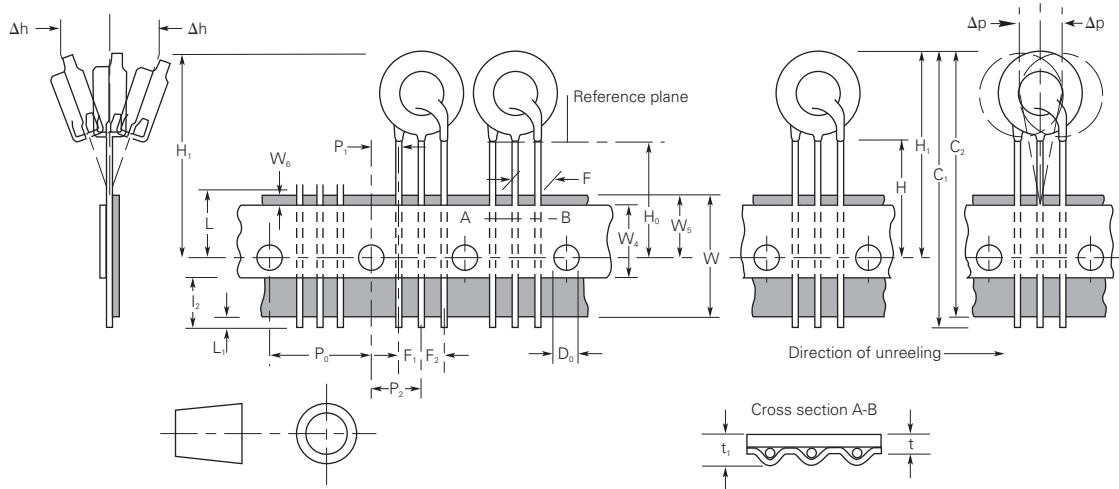
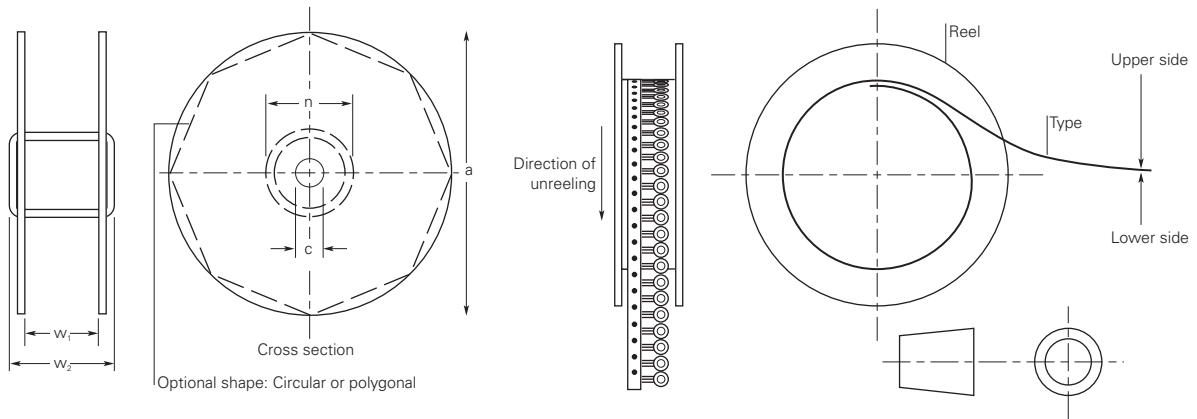
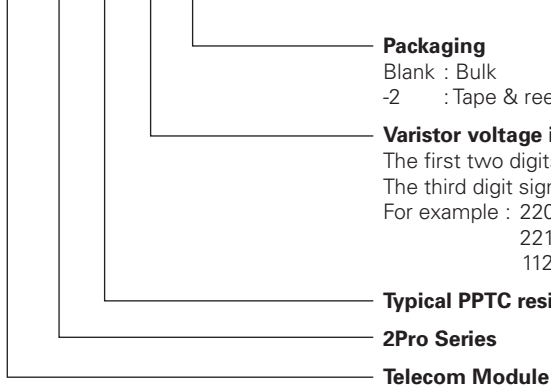

Figure 2P4 EIA Referenced Reel Dimensions for 2Pro Devices



Part Numbering System for 2Pro Devices

TM 2P- 10 271 -2



Packaging
Blank : Bulk
-2 : Tape & reel

Varistor voltage indicator
The first two digits indicate voltage.
The third digit signifies the power of ten.
For example : 220 : $22 \times 10^0 = 22V$
221 : $22 \times 10^1 = 220V$
112 : $11 \times 10^2 = 1100V$

Typical PPTC resistance (ohms)
2Pro Series
Telecom Module

Warning :

All information, including illustrations, is believed to be accurate and reliable. Users, however, should independently evaluate the suitability of and test each product selected for their application. Tyco Electronics Corporation makes no warranties as to the accuracy or completeness of the information, and disclaims any liability regarding its use. Tyco Electronics' only obligations are those in the Tyco Electronics' Standard Terms and Conditions of Sale for this product, and in no case will Tyco Electronics be liable for any incidental, indirect, or consequential damages arising from the sale, resale, use, or misuse of the product. Specifications are subject to change without notice. In addition, Tyco Electronics reserves the right to make changes to materials or processing that do not affect compliance with any applicable specification without notification to Buyer.