



RVT70AQLNWR00 V2

TN LVDS 7.0" LCD TFT DATASHEET

Rev.2.1
2021-11-23

ITEM	CONTENTS	UNIT
LCD Type	TFT/Transmissive/Normally white	/
Size	7.0	Inch
Viewing Direction	12:00	O'clock
Gray Scale Inversion Direction	6:00	O'clock
Outside Dimensions (W x H x D)	164.90 x 99.80 x 11.17	mm
Active Area (W x H)	154.08 x 85.92	mm
Pixel Pitch (W x H)	0.1790 x 0.1926	mm
Resolution	800 (RGB) x 480	/
Brightness	400	cd/m ²
LCD Interface Type	LVDS	/
Driver On Board	GM8284DD	/
Color Depth	16.7 M	/
Pixel Arrangement	RGB Vertical Stripe	/
With/Without Touch	With Resistive Touch Panel	/
Weight	TBD	g

Note 1: RoHS compliant

Note 2: LCM weight tolerance: $\pm 5\%$.



1. REVISION RECORD

REV NO.	REV DATE	CONTENTS	REMARKS
2.0	2021-03-24	Initial Release	
2.1	2021-11-23	Update the new template	



2. CONTENTS

1.	REVISION RECORD.....	2
2.	CONTENTS.....	3
3.	MODULE CLASSIFICATION INFORMATION.....	4
4.	MODULE DRAWING.....	5
5.	ABSOLUTE MAXIMUM RATINGS.....	6
6.	ELECTRICAL CHARACTERISTICS.....	6
7.	ELECTRO-OPTICAL CHARACTERISTICS.....	7
8.	INTERFACES DESCRIPTION.....	9
8.1	CN1 assignment.....	9
9.	TIMING CHARACTERISTICS.....	10
9.1	LVDS timing condition.....	10
9.2	AC characteristics.....	10
9.3	Clock and data input time diagram.....	11
9.4	Parallel RGB input timing table.....	11
10.	RESISTIVE TOUCH SCREEN PANEL SPECIFICATIONS.....	12
10.1	Electrical characteristics.....	12
10.2	Mechanical characteristics.....	12
11.	INSPECTION.....	13
11.1	Inspection condition.....	13
11.2	Inspection standard.....	14
12.	RELIABILITY TEST.....	17
13.	LEGAL INFORMATION.....	18



3. MODULE CLASSIFICATION INFORMATION

RV	T	70	A	Q	L	N	W	R	00	V2
1.	2.	3.	4.	5.	6.	7.	8.	9.	10.	11.

NO.	PARAMETER	SYMBOL
1.	BRAND	RV – Riverdi
2.	PRODUCT TYPE	T – TFT Standard
3.	DISPLAY SIZE	70 – 7.0"
4.	MODEL SERIAL NO.	A – (A - Z)
5.	RESOLUTION	Q – 800 x 480 px
6.	INTERFACE	L – TFT LCD, LVDS
7.	FRAME	N – Without Mounting Metal Frame
8.	BACKLIGHT TYPE	W – LED White
9.	TOUCH PANEL	R – With Resistive Touch Panel
10.	OPTION	00 – (00 - 99)
11.	VERSION	V2

Revision:	Changes:	Date:
2.0	LCD Change	2020.08.21

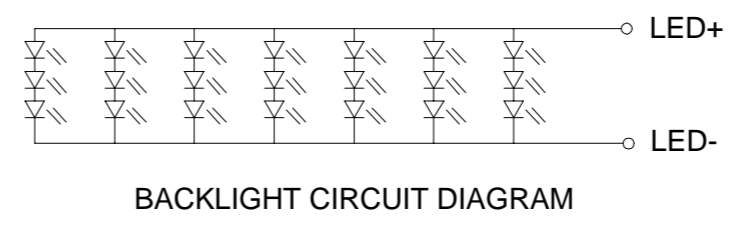
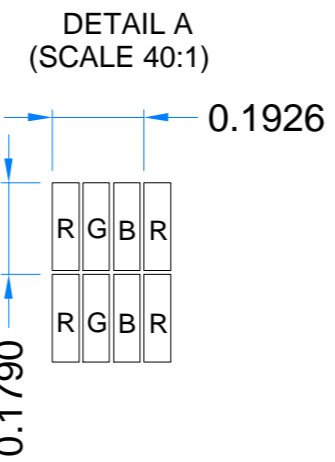
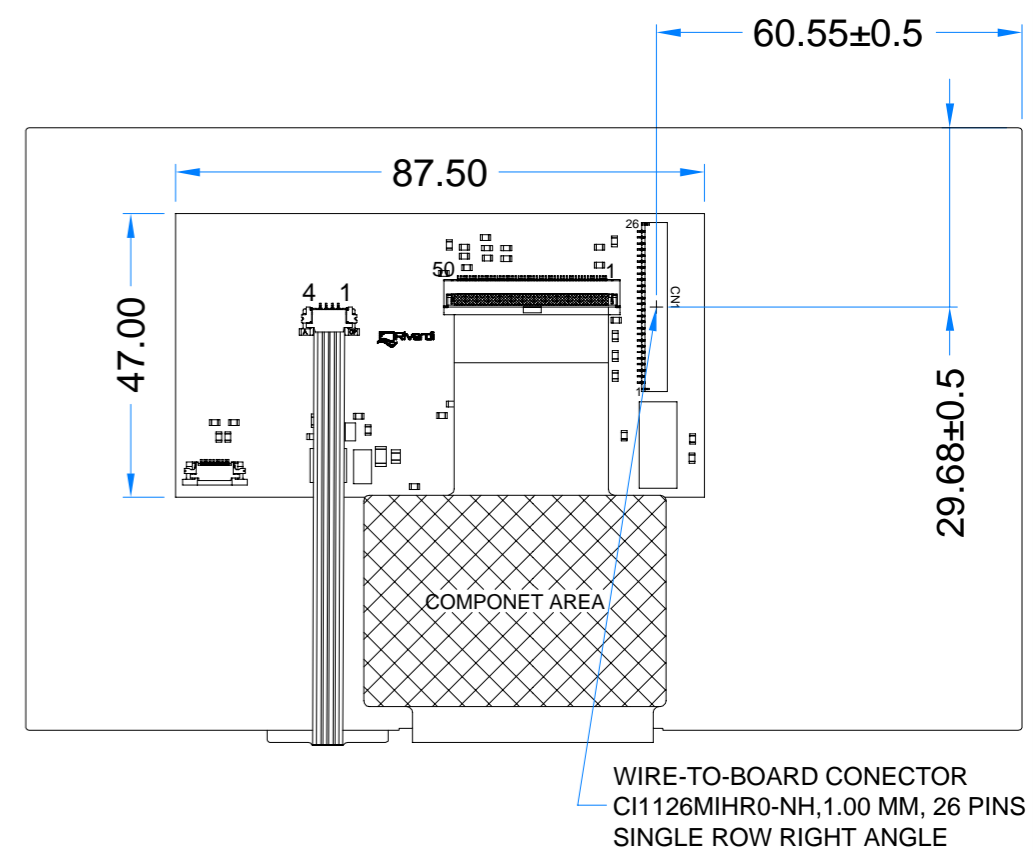
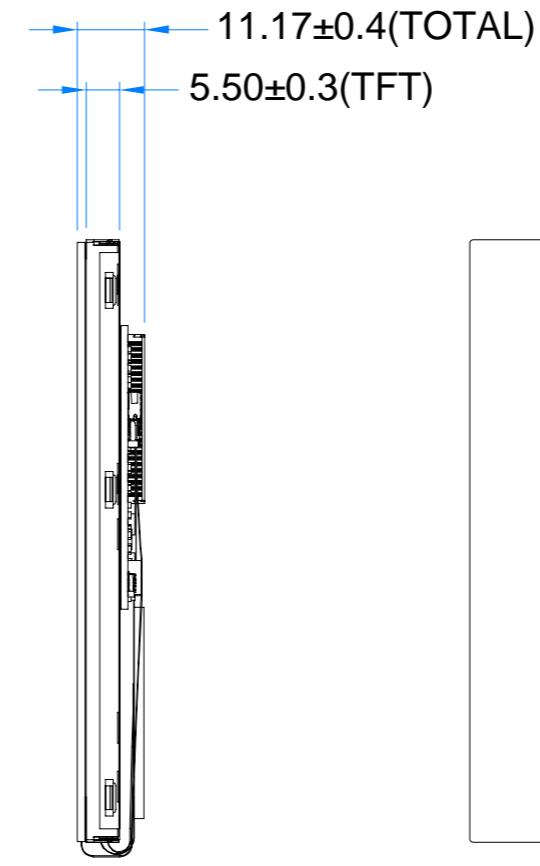
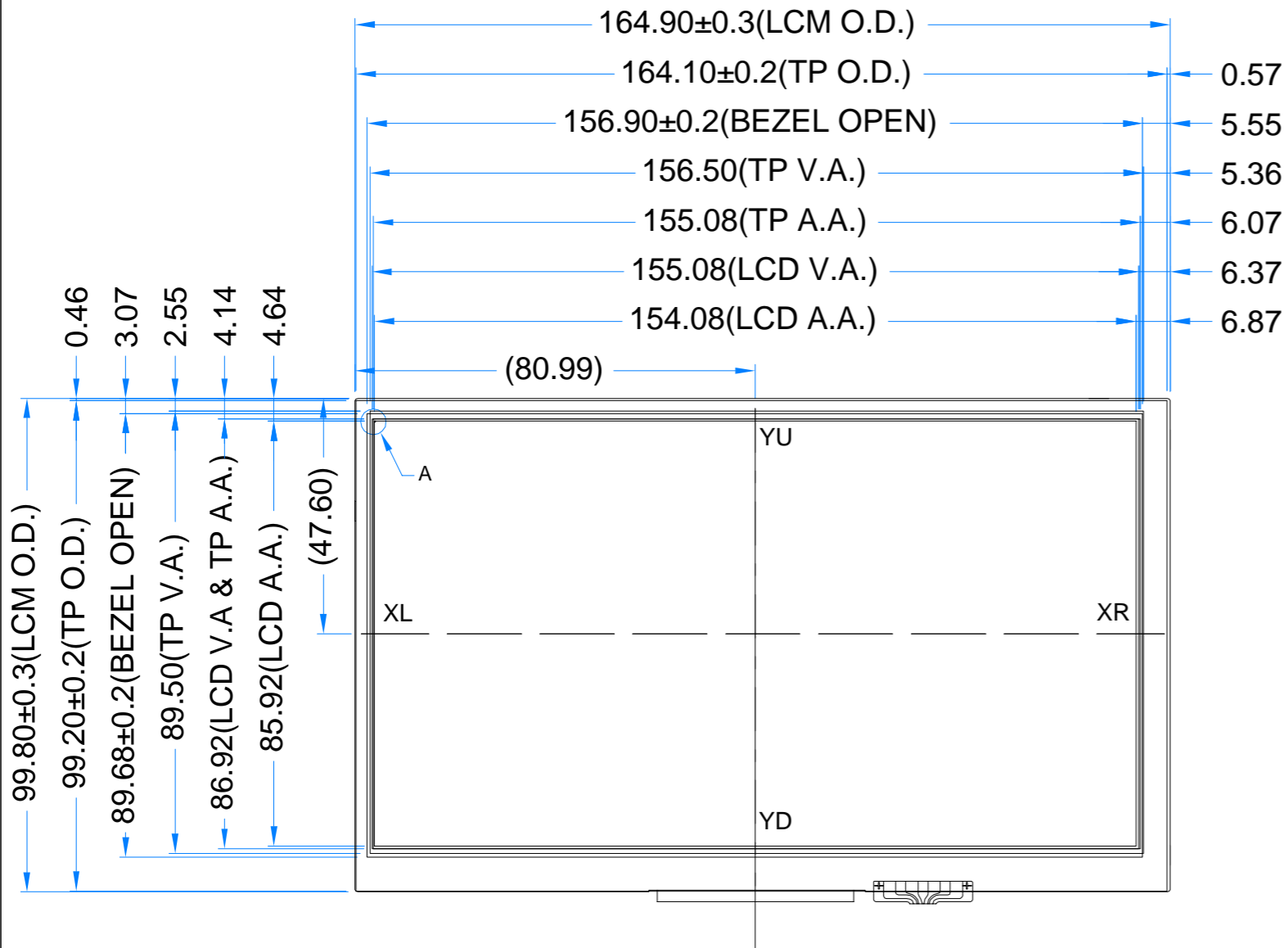

LCM NOTES:

1. DISPLAY TYPE: TFT, TRANSMISSIVE, NORMALLY WHITE
2. OPERATING VOLTAGE: VCC=3.3V
3. RESOLUTION: 800x480
4. VIEWING DIRECTION: 12 O'CLOCK
5. IC DRIVER: GM8284DD
6. LED BACKLIGHT: 21-LED WHITE, BUILT-IN LED INVERTER
7. SURFACE LUMINANCE: 400cd/m²

TP NOTES:

1. TP STRUCTURE: FILM TO GLASS, 4 ELECTRODE RESISTIVE TOUCH PANEL

GENERAL NOTES:

1. OPERATING TEMPERATURE: -20°C ~ 70°C
2. STORAGE TEMPERATURE: -30°C ~ 80°C
3. WITHOUT INDIVIDUAL TOLERANCE: ±0.3mm
4. RoHS COMPLIANT

PN: RVT70AQLNWR00 V2
 SN:
 DRAWN: M.Natywa
 CHECKED: Carol Gao
 APPR:

2020.08.21
 1:1.6
 [mm]
 ISO A3
 P. 1 of 1



5. ABSOLUTE MAXIMUM RATINGS

PARAMETER	SYMBOL	MIN	MAX	UNIT
Supply Voltage for Logic	VDD	-0.3	5.0	V
Input Voltage for Logic	VIN	-0.3	VDD	V
Input Voltage for LED Inverter	BLVDD	-0.3	7.0	V
Operating Temperature	T _{OP}	-20	70	°C
Storage Temperature	T _{ST}	-30	80	°C
Humidity	RH	-	90% (Max 60°C)	RH

6. ELECTRICAL CHARACTERISTICS

PARAMETER	SYMBOL	MIN	TYP	MAX	UNIT
Supply Voltage for Module	VDD	-	3.3	-	V
Input Voltage for LED Inverter	BLVDD	2.8	5.0	5.5	V
LED Backlight Current	IDD _{backlight} (@ 5V)	-	450	540	mA
Input Voltage ' H ' level	V _{IH}	0.7VDD	-	VDD	V
Input Voltage ' L ' level	V _{IL}	0	-	0.2VDD	V
LED Lifetime	-	30,000	50,000	-	Hrs

Note: The LED lifetime is defined as the module brightness decrease to 50% original brightness at Ta = 25°C.



7. ELECTRO-OPTICAL CHARACTERISTICS

Optical characteristics are determined after the unit has been 'ON' and stable for approximately 30 minutes in a dark environment at 25 °C. The values specified are at an approximate distance 500mm from the LCD surface at a viewing angle of Φ and θ equal to 0°.

ITEM	SYMBOL	CONDITION	MIN	TYP	MAX	UNIT	RMK	NOTE
Response Time	Tr+Tf	$\theta=0^\circ$ $\phi=0^\circ$ Ta=25 °C	-	20	35	ms	FIG 1.	4
Contrast Ratio	Cr		400	500	-	---	FIG 2.	1
Luminance Uniformity	δ WHITE		70	75	-	%	FIG 2.	3
Surface Luminance	Lv		-	400	-	cd/m ²	FIG 2.	2
Viewing Angle Range	θ	$\phi = 90^\circ$	40	50	-	deg	FIG 3.	6
		$\phi = 270^\circ$	60	70	-	deg	FIG 3.	
		$\phi = 0^\circ$	60	70	-	deg	FIG 3.	
		$\phi = 180^\circ$	60	70	-	deg	FIG 3.	
CIE (x, y) Chromaticity	Rx	$\theta=0^\circ$ $\phi=0^\circ$ Ta=25 °C	0.522	0.572	0.622	-	FIG 2.	5
	Ry		0.300	0.350	0.400	-		
	Gx		0.311	0.361	0.411	-		
	Gy		0.526	0.576	0.626	-		
	Bx		0.097	0.147	0.197	-		
	By		0.038	0.088	0.138	-		
	Wx		0.266	0.316	0.366	-		
	Wy		0.266	0.316	0.366	-		

Note 1. Contrast Ratio (CR) is defined mathematically as below, for more information see Figure 2.

$$\text{Contrast Ratio} = \frac{\text{Average Surface Luminance with all white pixels (P1, P2, P3, P4, P5)}}{\text{Average Surface Luminance with all black pixels (P1, P2, P3, P4, P5)}}$$

Note 2. Surface luminance is the LCD surface from the surface with all pixels displaying white. For more information see Figure 2.

$$Lv = \text{Average Surface Luminance with all white pixels (P1, P2, P3, P4, P5)}$$

Note 3. The uniformity in surface luminance δ WHITE is determined by measuring luminance at each test position 1 through 5, and then dividing the minimum luminance of 5 points luminance by maximum luminance of 5 points luminance. For more information see Figure 2.

$$\delta \text{ WHITE} = \frac{\text{Minimum Surface Luminance with all white pixels (P1, P2, P3, P4, P5)}}{\text{Maximum Surface Luminance with all white pixels (P1, P2, P3, P4, P5)}}$$

Note 4. Response time is the time required for the display to transition from white to black (Rise Time, Tr) and from black to white (Decay Time, Tf). For additional information see Figure 1. The test equipment is Autronic-Melchers's ConoScope series.

Note 5. CIE (x, y) chromaticity, the x, y value is determined by measuring luminance at each test position 1 through 5, and then make average value.



Note 6. Viewing angle is the angle at which the contrast ratio is greater than 2. For TFT module the contrast ratio is greater than 10. The angles are determined for the horizontal or x axis and the vertical or y axis with respect to the z axis which is normal to LCD surface. For more information see Figure 3.

Note 7. For viewing angle and response time testing, the testing data is based on Autronic-Melchers's ConoScope series. Instruments for Contrast Ratio, Surface Luminance, Luminance Uniformity, CIE the test data is based on TOPCON's BM-5 photo detector.

Figure 1. The definition of response time

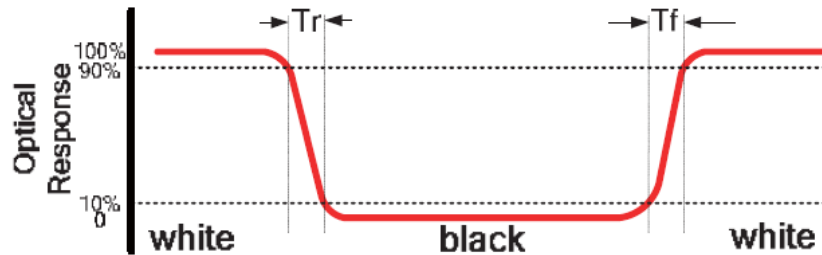
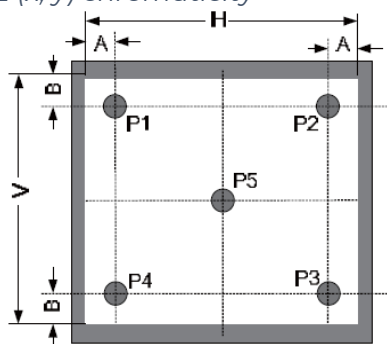

Figure 2. Measuring method for Contrast ratio, surface luminance, Luminance uniformity, CIE (x, y) chromaticity



A: 5mm

B: 5mm

H, V: Active Area

Light spot size $\varnothing=5\text{mm}$, 500mm distance from the LCD surface to detector lens.

Measurement instrument is TOPCON'S luminance meter BM-5

Figure 3. The definition of viewing angle

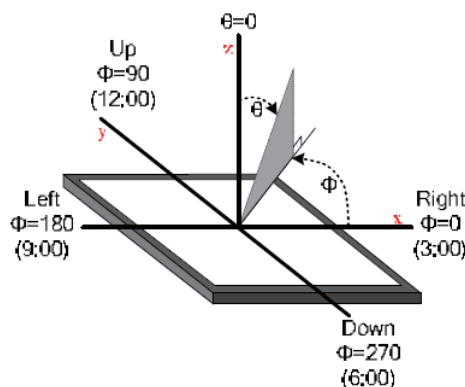



8. INTERFACES DESCRIPTION

8.1 CN1 assignment

PIN NO.	SYMBOL	DESCRIPTION
1	GND	Power Ground
2	RXCLK+	LVDS Clock Output Signal +
3	RXCLK-	LVDS Clock Output Signal -
4	GND	Power Ground
5	RXC0+	LVDS Channel 0 Input Signal +
6	RXC0-	LVDS Channel 0 Input Signal -
7	GND	Power Ground
8	RXC1+	Channel 1 Input Signal +
9	RXC1-	Channel 1 Input Signal -
10	GND	Power Ground
11	RXC2+	LVDS Channel 2 Input Signal +
12	RXC2-	LVDS Channel 2 Input Signal -
13	VDD	Power Supply: +3.3V
14	RXC3+	LVDS Channel 3 Input Signal +
15	RXC3-	LVDS Channel 3 Input Signal -
16	VDD	Power Supply: +3.3V
17	RESET	Global Reset Pin
18	BLGND	Backlight Ground
19	BLGND	Backlight Ground
20	BLVDD	Backlight Supply Voltage
21	BLVDD	Backlight Supply Voltage
22	BELENA	Enable Signal Control System
23	XL	X - Left
24	YD	Y - Bottom
25	XR	X - Right
26	YU	Y - Up



9. TIMING CHARACTERISTICS

9.1 LVDS timing condition

PARAMETER	SYMBOL	MIN	TYP	MAX	UNIT
CLK OUT Period	tRCP	11.76	30.06(T)	50.0	ns
CLK OUT High Time	tRCH	-	4T/7	-	ns
CLK OUT Low Time	tRCL	-	3T/7	-	ns
RCLK+/- to CLK OUT Delay	tRCD	-	5T/7	-	ns
TTL Data Setup to CLK OUT	tRS	0.35T-0.3	-	-	ns
TTL Data Hold from CLK OUT	tRH	0.45T-1.6	-	-	ns
TTL Low to High Transition Time	tTLH	-	2.0	3.0	ns
TTL Low to Low Transition Time	tTHL	-	1.8	3.0	ns
Input Data Position0 (T=11.76ns)	tRIP1	-0.4	0.0	0.4	ns
Input Data Position0 (T=11.76ns)	tRIP0	T/7-0.4	T/7	T/7+0.4	ns
Input Data Position0 (T=11.76ns)	tRIP6	2T/7-0.4	2T/7	2T/7+0.4	ns
Input Data Position0 (T=11.76ns)	tRIP5	3T/7-0.4	3T/7	3T/7+0.4	ns
Input Data Position0 (T=11.76ns)	tRIP4	4T/7-0.4	4T/7	4T/7+0.4	ns
Input Data Position0 (T=11.76ns)	tRIP3	5T/7-0.4	5T/7	5T/7+0.4	ns
Input Data Position0 (T=11.76ns)	tRIP2	6T/7-0.4	6T/7	6T/7+0.4	ns
Phase Lock Loop Set	tRPLL	-	-	10	ms

9.2 AC characteristics

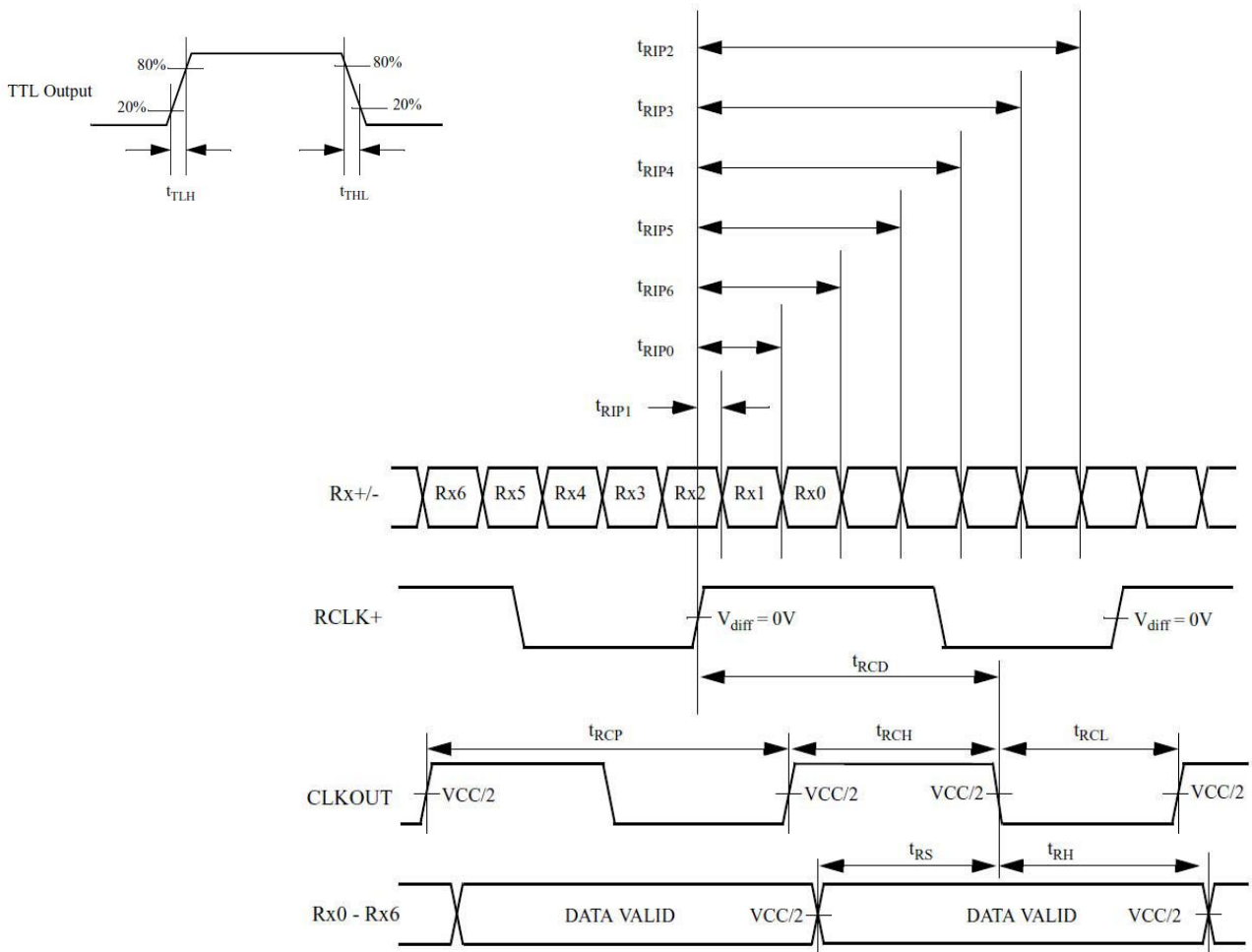



9.3 Clock and data input timing diagram

Horizontal input timing diagram



Vertical input timing diagram

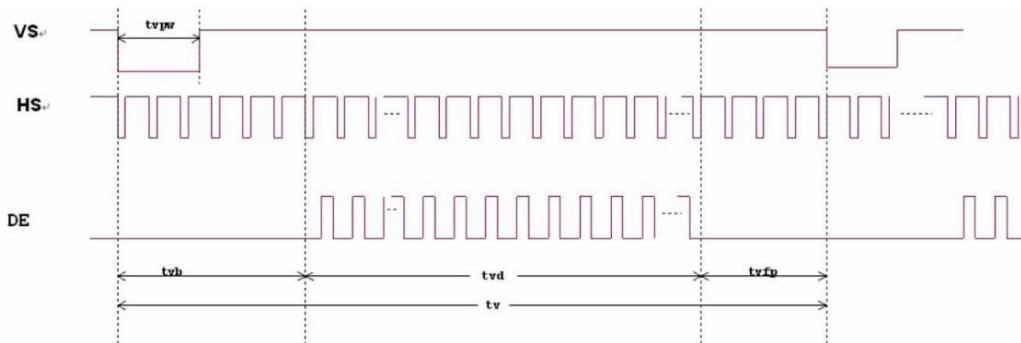

9.4 Parallel RGB input timing table

PARAMETER	SYMBOL	MIN	TYP	MAX	UNIT
DCLK Frequency	Fclk	26.0	30.0	36.0	MHz
VSD Period Time	Tv	515	525	535	TH
VSD Display Area	Tvd		480		
VSD Blanking	Tvb		10		
VSD Front Porch	Tvfp	12	22	32	
VSD Pulse Width	Tvpw	-	13	-	DCLK
HSD Pulse Width	Thpw	-	30	-	
HSD Period Time	Th	1026	1056	1086	
HSD Display Area	Thd		800		
HSD Blanking	Thb		16		
HSD Front Porch	Thfp	180	210	240	

10. RESISTIVE TOUCH SCREEN PANEL SPECIFICATIONS

10.1 Electrical characteristics

ITEM	VALUE			UNIT	REMARK
	Min.	Typ.	Max.		
Linearity	3.0	-	-	%	Analog X and Y directions
Terminal Resistance	440	-	1100	Ω	X (Film side)
	100	-	420	Ω	Y (Glass side)
Insulation Resistance	25	-	-	M Ω	DC 25V
Voltage	-	-	10	V	DC
Chattering	-	-	10	ms	100k Ω pull-up
Transparency	78	-	-	%	

Note. Avoid operating with hard or sharp material such as a ball point pen or a mechanical pencil except a polyacetal pen (tip R 0.8mm or less) or a finger.

10.2 Mechanical characteristics

ITEM	VALUE			UNIT	REMARK
	Min.	Typ.	Max.		
Activation Force	20	-	100	gf	Note 1
Durability-Surface Scratching	Write 100,000	-	-	characters	Note 2
Durability-Surface Pitting	1,000 000	-	-	touches	Note 3
Surface Hardness	3	-	-	H	JIS K5400

Note 1: Activation force test condition

(1) Input DC 5V on X direction, drop off Polyacetal Stylus (R0.8), until output voltage stabilizes, then get the activation force.

(2) R8.0mm Silicon rubber for finger Activation force test.

(3) Test point: 9 points.

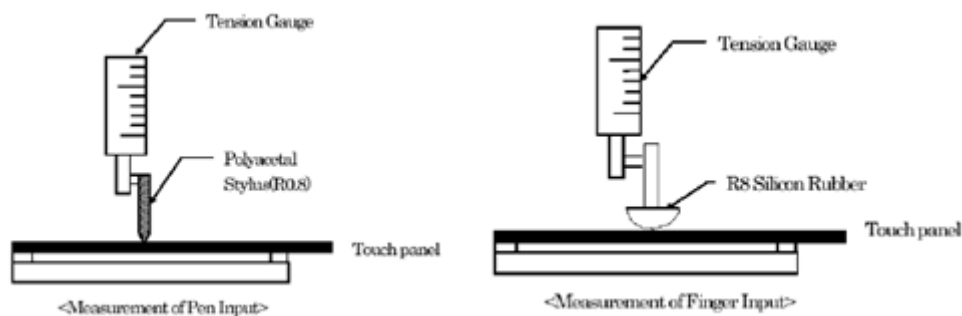

Note 2: Measurement for surface area.

(1) Scratch 100,000 times straight line on the film with a stylus change every 20,000 times.

(2) Force: 100gf.

(3) Speed: 60mm/sec.

(4) Stylus: R0.8 polyacetal tip.

Note 3: Pit 1,000,000 times on the film with a R0.8 silicon rubber.

(1) Force: 100gf.

(2) Speed: 2times/sec.

11. INSPECTION

Standard acceptance/rejection criteria for TFT module

11.1 Inspection condition

Ambient conditions:

- Temperature: $25 \pm 2^{\circ}\text{C}$
- Humidity: $(60 \pm 10) \% \text{RH}$
- Illumination: Single fluorescent lamp non-directive (300 to 700 lux)

Viewing distance: $35 \pm 5\text{cm}$ between inspector bare eye and LCD.

Viewing Angle: U/D: $45^{\circ}/45^{\circ}$, L/R: $45^{\circ}/45^{\circ}$

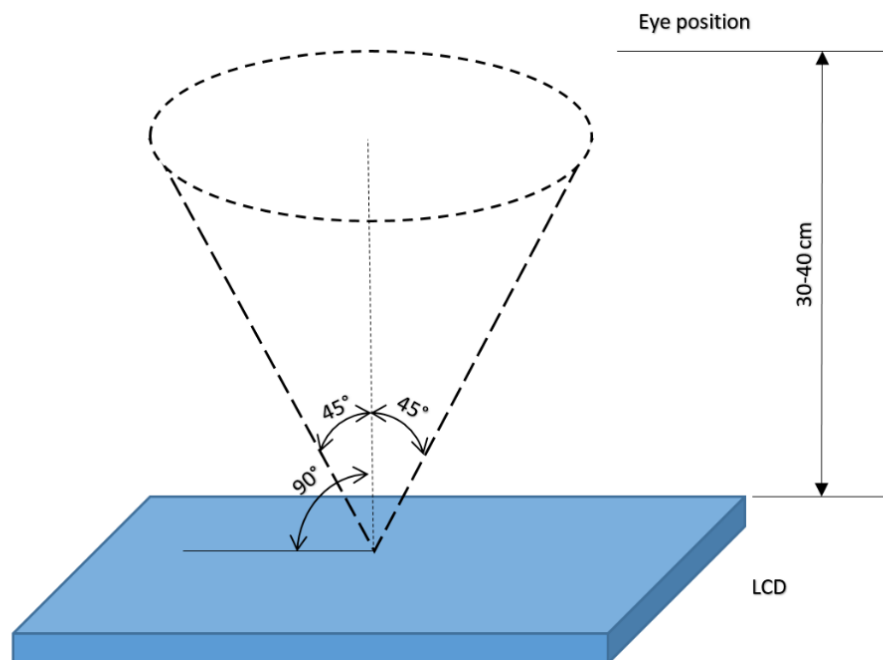

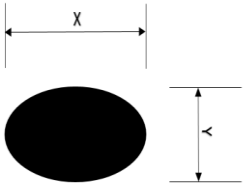
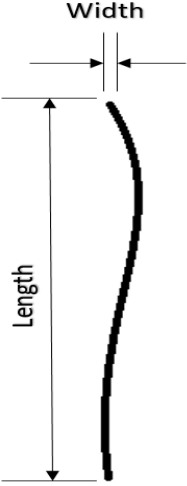

11.2 Inspection standard

Item	Criterion																																		
<p>Black spots, white spots, light leakage, Foreign Particle (round Type)</p>	<div style="display: flex; align-items: center; justify-content: center;">  <table border="1" style="margin-left: 20px;"> <thead> <tr> <th colspan="2" style="background-color: #0056b3; color: white;">Size < 5"</th> </tr> <tr> <th>Average Diameter</th> <th>Qualified Qty</th> </tr> </thead> <tbody> <tr> <td>D < 0.2 mm</td> <td>Ignored</td> </tr> <tr> <td>0.2 mm < D < 0.3 mm</td> <td>3</td> </tr> <tr> <td>0.3 mm < D < 0.5 mm</td> <td>2</td> </tr> <tr> <td>0.5 mm < D</td> <td>0</td> </tr> </tbody> </table> </div> $D = \frac{(x + y)}{2}$ <p>*Spots density: 10 mm</p>	Size < 5"		Average Diameter	Qualified Qty	D < 0.2 mm	Ignored	0.2 mm < D < 0.3 mm	3	0.3 mm < D < 0.5 mm	2	0.5 mm < D	0																						
Size < 5"																																			
Average Diameter	Qualified Qty																																		
D < 0.2 mm	Ignored																																		
0.2 mm < D < 0.3 mm	3																																		
0.3 mm < D < 0.5 mm	2																																		
0.5 mm < D	0																																		
<p>LCD black spots, white spots, light leakage (line Type)</p>	<div style="display: flex; align-items: center; justify-content: center;">  <table border="1" style="margin-left: 20px;"> <thead> <tr> <th colspan="3" style="background-color: #0056b3; color: white;">Size < 5"</th> </tr> <tr> <th>Length</th> <th>Width</th> <th>Qualified Qty</th> </tr> </thead> <tbody> <tr> <td>-</td> <td>W < 0.02</td> <td>Ignored</td> </tr> <tr> <td>L < 3.0</td> <td>0.02 < W < 0.05</td> <td rowspan="2">2</td> </tr> <tr> <td>L < 2.5</td> <td>0.05 < W < 0.08</td> </tr> <tr> <td>-</td> <td>0.08 < W</td> <td>0</td> </tr> </tbody> </table> </div> <table border="1" style="margin-left: 20px; margin-top: 10px;"> <thead> <tr> <th colspan="3" style="background-color: #0056b3; color: white;">Size >= 5"</th> </tr> <tr> <th>Length</th> <th>Width</th> <th>Qualified Qty</th> </tr> </thead> <tbody> <tr> <td>-</td> <td>W < 0.02</td> <td>Ignored</td> </tr> <tr> <td>L < 3.0</td> <td>0.02 < W < 0.05</td> <td rowspan="2">4</td> </tr> <tr> <td>L < 2.5</td> <td>0.05 < W < 0.08</td> </tr> <tr> <td>-</td> <td>0.08 < W</td> <td>0</td> </tr> </tbody> </table> <p>*Spots density: 10 mm</p>	Size < 5"			Length	Width	Qualified Qty	-	W < 0.02	Ignored	L < 3.0	0.02 < W < 0.05	2	L < 2.5	0.05 < W < 0.08	-	0.08 < W	0	Size >= 5"			Length	Width	Qualified Qty	-	W < 0.02	Ignored	L < 3.0	0.02 < W < 0.05	4	L < 2.5	0.05 < W < 0.08	-	0.08 < W	0
Size < 5"																																			
Length	Width	Qualified Qty																																	
-	W < 0.02	Ignored																																	
L < 3.0	0.02 < W < 0.05	2																																	
L < 2.5	0.05 < W < 0.08																																		
-	0.08 < W	0																																	
Size >= 5"																																			
Length	Width	Qualified Qty																																	
-	W < 0.02	Ignored																																	
L < 3.0	0.02 < W < 0.05	4																																	
L < 2.5	0.05 < W < 0.08																																		
-	0.08 < W	0																																	



Item	Criterion	
Clear spots	Size < 5"	
	Average Diameter	Qualified Qty
	D < 0.2 mm	Ignored
	0.2 mm < D < 0.3 mm	3
	0.3 mm < D < 0.5 mm	2
	0.5 mm < D	0
	Size >= 5"	
	Average Diameter	Qualified Qty
	D<0.2 mm	Ignored
	0.2 mm < D < 0.3 mm	4
	0.3 mm < D < 0.5 mm	2
	0.5 mm < D	0
	*Spots density: 10 mm	
	Polarizer bubbles	Size < 5"
Average Diameter		Qualified Qty
D < 0.2 mm		Ignored
0.2 mm < D < 0.5 mm		3
0.5 mm < D < 1 mm		2
1 mm < D		0
Total Q'ty		3
Size >= 5"		
Average Diameter		Qualified Qty
D<0.25 mm		Ignored
0.25 mm < D < 0.5 mm		3
0.5 mm < D		0
Electrical Dot Defect		Size < 5"
		item
	Black do defect	4
	Bright dot defect	2
	Total Dot	5
	Size >= 5"	
	item	Qualified Qty
	Black do defect	5
	Bright dot defect	2
	Total Dot	5



Touch panel spot	Size < 5"	
	Average Diameter	Qualified Qty
	D < 0.2 mm	Ignored
	0.2 mm < D < 0.4 mm	5
	0.4 mm < D < 0.5 mm	2
	0.5 mm < D	0
	Size >= 5"	
	Average Diameter	Qualified Qty
	D < 0.25 mm	Ignored
	0.25 mm < D < 0.5 mm	4
0.5 mm < D	0	
Touch panel White line Scratch	Size < 5"	
	Length	Width
	-	W < 0.02
	L < 3.0	0.02 < W < 0.05
	L < 2.5	0.05 < W < 0.08
	-	0.08 < W
	Size >= 5"	
	Length	Width
	-	W < 0.03
	L < 5.0	0.03 < W < 0.05
-	0.05 < W	



12. RELIABILITY TEST

NO.	TEST ITEM	TEST CONDITION
1	High Temperature Storage	80±2°C/240hours
2	Low Temperature Storage	-30±2°C/240hours
3	High Temperature Operating	70±2°C/240hours
4	Low Temperature Operating	-20±2°C/240hours
5	Temperature Cycle	-30±2°C ~ 25 ~ 80±2°C x 20 cycles (30min.) (5min.) (30min.)
6	Damp Proof Test	60°C ± 5°C × 90%RH/240hours
7	Vibration Test	Frequency 10Hz~55Hz Amplitude of vibration: 1.5mm Sweep time: 11Mins Test period: Cycles For Each Direction of X, Y, Z (Packing Condition)
8	Shortage Test (Non- operating)	Random vibration :0.15G*G/HZ from 5-200HZ, -6dB/Octave from 200-500HZ of each direction of X.Y. Z (6 hours for total)
9	Package Drop Test	100G, 6Ms Direction: ±X, ±Y, ±Z Cycle: 3 Times

Note 1: Without water condensation.

Note 2: The function test shall be conducted after 2 hours storage at the room temperature (25°C±2°C) and room humidity (65%±5%) after removed from the test chamber. In the standard conditions, there shall be no functional defects occurred.



13. LEGAL INFORMATION

Riverdi grants the guarantee for the proper operation of the goods for a period of 12 months from the date of possession of the goods. If in a consequence of this guaranteed execution the customer has received the defects-free item as replacement for the defective item, the effectiveness period of this guarantee shall start anew from the moment the customer receives the defects-free item.

Information about device is the property of Riverdi and may be the subject of patents pending or granted. It is not allowed to copy or disclosed this document without prior written permission.

Riverdi endeavors to ensure that all contained information in this document is correct but does not accept liability for any error or omission. Riverdi products are in developing process and published information may be not up to date. Riverdi reserves the right to update and makes changes to Specifications or written material without prior notice at any time. It is important to check the current position with Riverdi.

Images and graphics used in this document are only for illustrative the purpose. All images and graphics are possible to be displayed on the range products of Riverdi, however the quality may vary. Riverdi is no liable to the buyer or to any third party for any indirect, incidental, special, consequential, punitive or exemplary damages (including without limitation lost profits, lost savings, or loss of business opportunity) relating to any product, service provided or to be provided by Riverdi, or the use or inability to use the same, even if Riverdi has been advised of the possibility of such damages.

Riverdi products are not fault tolerant nor designed, manufactured or intended for use or resale as on line control equipment in hazardous environments requiring fail-safe performance, such as in the operation of nuclear facilities, aircraft navigation or communication systems, air traffic control, direct life support machines or weapons systems in which the failure of the product could lead directly to death, personal injury or severe physical or environmental damage ('High-Risk Activities'). Riverdi and its suppliers specifically disclaim any expressed or implied warranty of fitness for High-Risk Activities. Using Riverdi products and devices in 'High-Risk Activities' and in any other application is entirely at the buyer's risk, and the buyer agrees to defend, indemnify and hold harmless Riverdi from all damages, claims or expenses resulting from such use. No licenses are conveyed, implicitly or otherwise, under any Riverdi intellectual property rights.

Hi, I am here to help you!
If you have any additional
questions, please contact
our support via email:
contact@riverdi.com

