

Fig1. MEASURING METHOD

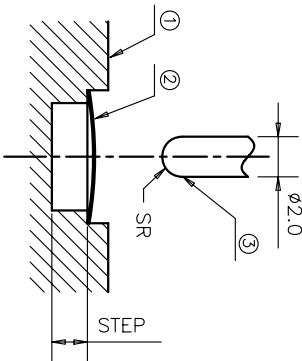

Fig2. OPERATING PERFORMANCE

NOTES:
 1. ALL THE OPERATING PERFORMANCE SPEC. IN BELLOW TABLE SHOULD BE MET. THE MEASURE METHOD IS SHOWN AS Fig.1.
 OPERATE THE DOME 10 TIMES BEFORE MEASURING.

REV	ECN NO.	APPD
A	HC060009	ZO
B	HC100097	ZO
C	HC150011	ZO

F_p: PEAK FORCE
 F_r: RETURN FORCE
 T1: CONTACT POINT
 T2: BUTTON POINT
 C/R=(F_p-F_r)/F_p*100%
 REMARK:
 1. T2 TESTED WHEN THE SETP IS DEEP ENOUGH TO NOT CONTACT WITH DOME DURING MEASURING.
 2. T1 < T2

- 1) TEST SPEED : 120 SPM
- 2) TEST FORCE : F_p
- 3) MATERIAL : ALUMINIUM.
2. OBVIOUS BURR, SCRATCHES, CRACKES IS FORBIDDEN.
3. DIMENSIONS MARKED ∇ SHOULD BE CHECKED BY Q.C. AND P.E.
4. DIMENSIONING SHALL BE INTERPRETED PER ANSI Y14.5M-1982.
5. HARMFUL MATERIAL CONTROL PLEASE FOLLOW DOC."HY-QW-02".
6. PART PERFORMANCE TABLE

PART NAME	D	W	H	P.F(gf)	C/R(%)
610-5***-***	$\phi 5 \pm 0.05$	3.7±0.05	0.25±0.05	CP±15	C/R±10
610-C***-***	$\phi 4.5 \pm 0.05$	3.3±0.05	0.22±0.05	CP±15	C/R±10
610-4***-***	$\phi 4 \pm 0.05$	2.8±0.05	0.2±0.05	CP±15	C/R±10
610-F***-***	$\phi 2.4 \pm 0.05$	2.2±0.05	0.15±0.05	CP±15	C/R±10
610-D***-***	$\phi 2.2 \pm 0.05$	1.6±0.05	0.13±0.05	CP±15	C/R±10
610-2***-***	$\phi 2 \pm 0.05$	1.5±0.05	0.12±0.05	CP±15	C/R±10

TYPE:	DIMPLE:	D:	C/R:	STEP:	MATERIAL:	CP:
□	0	2=φ2.0mm	0=60%	0=0.00mm	9=SUS	060=060gf
□	1	3=φ3.0mm	1=65%	1=0.01mm	0=Ni-SUS	080=080gf
□	3	4=φ4.0mm	2=55%	2=0.02mm	S=AG-SUS	100=100gf
□	4	5=φ5.0mm	3=45%	3=0.03mm	1=PB	130=130gf
□	5	6=φ6.0mm	4=35%	4=0.04mm	2=BECU	160=160gf
□		A=φ2.5mm	5=25%	5=0.05mm		180=180gf
□		B=φ3.5mm	6=15%	6=0.06mm		200=200gf
□		C=φ4.5mm		7=0.07mm		250=250gf
□		D=φ2.2mm		8=0.08mm		
□		E=φ2.3mm		9=0.09mm		
□		F=φ2.4mm		A=0.10mm		
□		G=φ2.7mm				
□		H=φ2.8mm				
□		J=φ2.9mm				
□		K=φ2.85mm				
□		L=φ2.92mm				

X. ± 0.2	X'. ± 0.3	UNITS	MM	NAME(INTENDED USE)	HON YUAN
.X ± 0.1	.X' ± 2'	MATL		METAL DOME FOR TACT SWITCH	HON YUAN PRECISION IND. CO.,LTD. SHENZHEN, CHINA, R.O.C.
.XX ± 0.05	.XX' ± 1'	FINISH		PART NO.(INTENDED USE)	TITLE: DOME CUSTOMER DRAWING
.XXX ± 0.03	.XXX' ± 0.5'			610-****-***	
APPD: ZO 6/04/2015 CHKD: M.H.L: 6/04/2015 DR: WP.Lu 6/03/2015				DWG NO.:	610-0000-000
THESE DRAWINGS AND SPECIFICATIONS ARE THE PROPERTY OF HON YUAN PRECISION IND. CO., LTD. AND SHALL NOT BE REPRODUCED, COPIED OR USED IN ANY MANNER WITHOUT THE PRIOR WRITTEN CONSENT OF HON YUAN PRECISION IND. CO., LTD.				SCALE SHEET	1/1
				REV.	1/5
					C