

18D

Electro-mechanical hydraulic pressure switches



- > 5 to 420 bar
Port size: G1/4, 1/4 NPT
7/16-20 UNF (SAE 4) Flange
(CETOP)
- > Microswitch with gold plated contacts
- > High number of switching cycles
- > Vibration resistant to 15 g
- > Microswitch approved by UL and CSA
- > Intrinsically safe operation



Technical features

Medium:

For neutral, self lubricating fluids, e.g. hydraulic oil, lube oil, light fuel oil

Operation:

Softseal piston

Operating pressure:

5 ... 420 bar (72 ... 6091 psi)

Repeatability:

±4% of final value (depending on regulating pressure)

Media viscosity:

Up to 1000 mm²/s

Switching cycles:

100 1/min

Switching pressure difference/hysteresis:

Fixed

Life cycle of mechanical parts:

10⁷ switching cycles

Switching element:

Microswitch with gold plated contacts

Degree of protection:

IP65 for DIN EN 175301-803 (DIN 43650) form A connection
IP67 for M12 x 1 connection

Mounting position:

Optional

Weight:

0,2 kg (0.44 lbs)

Electrical connection:

DIN EN 175301-803 (DIN 43650) form A or M12 x 1 IEC 947-5-2

Ambient/Media temperature:

-25 ... +80°C (-13 ... +176°F)
Air supply must be dry enough to avoid ice formation at temperatures below +2°C (+35°F)

Materials:

Body: Aluminium/steel
Seals: PTFE, NBR

Technical data

DIN plug connection – plug included in scope of supply

Symbol	Port size	Pressure range *1)		Switching pressure difference				Materials press sensor		Drawing No.	Model
		(bar)	(psi)	Lower range (bar)	Upper range (psi)	Body	Seal				
	1/4"	5 ... 70	72 ... 1015	10,5	152	15	217	AL/Stahl	PTFE/NBR	1	
	Flansch	5 ... 70	72 ... 1015	10,5	152	15	217	AL/Stahl	PTFE/NBR	2	
	7/16-20 UNF	5 ... 70	72 ... 1015	10,5	152	15	217	AL/Stahl	PTFE/NBR	1	
	Flansch (CETOP)	10 ... 160	145 ... 2320	11	159	17	246	AL/Stahl	PTFE/NBR	3	
	1/4"	10 ... 160	145 ... 2320	11	159	17	246	AL/Stahl	PTFE/NBR	1	
	Flansch	10 ... 160	145 ... 2320	11	159	17	246	AL/Stahl	PTFE/NBR	2	
	7/16-20 UNF	10 ... 160	145 ... 2320	11	159	17	246	AL/Stahl	PTFE/NBR	1	
	1/4"	25 ... 250	362 ... 3625	11	159	17	246	AL/Stahl	PTFE/NBR	1	
	Flansch	25 ... 250	362 ... 3625	11	159	17	246	AL/Stahl	PTFE/NBR	2	
	7/16-20 UNF	25 ... 250	362 ... 3625	11	159	17	246	AL/Stahl	PTFE/NBR	1	
	Flansch (CETOP)	40 ... 420	580 ... 6091	17	246	35	507	AL/Stahl	PTFE/NBR	3	
	1/4"	40 ... 420	580 ... 6091	17	246	38	551	AL/Stahl	PTFE/NBR	1	08824#0
	Flansch	40 ... 420	580 ... 6091	17	246	38	551	AL/Stahl	PTFE/NBR	2	
	7/16-20 UNF	40 ... 420	580 ... 6091	17	246	38	551	AL/Stahl	PTFE/NBR	1	

M12 x 1 Connection – plug not included, max. allowable voltage 30

Symbol	Port size	Pressure range *1)		Switching pressure difference				Materials press sensor		Drawing No.	Model
		(bar)	(psi)	Lower range (bar)	Upper range (bar)	Lower range (psi)	Upper range (psi)	Body	Seal		
	G1/4	5 ... 70	72 ... 1015	10,5	152	15	217	AL/Stahl	PTFE/NBR	1	
	Flansch	5 ... 70	72 ... 1015	10,5	152	15	217	AL/Stahl	PTFE/NBR	2	
	G1/4	10 ... 160	145 ... 2320	11	159	17	246	AL/Stahl	PTFE/NBR	1	
	Flansch	10 ... 160	145 ... 2320	11	159	17	246	AL/Stahl	PTFE/NBR	2	

Please insert '0' for ISO G, '2' for NPT thread

*1) Setpoints should be ideally in the middle of the switching pressure range. Reference pressure = atmospheric pressure. Switching pressure must not exceed the indicated values.

Accessories

Pressure port reducing nipple	Surge damper	Cover
Page 3	Page 3	Page 3
0574767 (brass)	0574773 (brass)	0554737
0550083 (stainless steel)	0553258 (stainless steel)	

Connector DIN EN 175301-803	Connector M 12 x 1 4-pin, 90°	4-pin, straight		
0570110 (Form A)	0523058 (2 m cable, 4-core)	0523056 (without cable)	0523057 (2 m cable, 4-core)	0523055 (without cable)
	0523053 (5 m cable, 4-core)		0523052 (5 m cable, 4-core)	

Switching function

	Connector DIN EN 175301-803, form A Microswitch SPDT Terminals 1 - 3: Contacts close on rising pressure. Terminals 1 - 2: Contacts open on rising pressure.		Connector M12 x 1 Microswitch SPDT Terminals 1 - 4: Contacts close on rising pressure. Terminals 1 - 2: Contacts open on rising pressure.
--	--	--	---

Switching capacity

Commutator with gold plated contacts

Current type	Load type *2)	U min [V]	Max. permissible persistent current I _{max} [A] at U *1) (UL & CSA)					Electrical life-time
			M12 x 1 30 V	DIN EN 175301-803, form A 30 V	48 V	125 V	250 V	
a.c.	Ohmic, inductive	6	0,1	0,1	0,1	0,1	0,1	≥ 2 x 10 ⁵ Switching cycles
d.c.	Ohmic, inductive	6	0,1	0,1	—	—	—	

Reference number: 20/min, Reference temperature: +20°C.

I_{min} = 1 mA at 24 V d.c. or 5 mA at 6 V d.c.

*1) Higher currents (5 A max) will cause a reduction of the durability of the micro-switch contacts. Furthermore additional measures has to be taken to fulfil the EMV regulation 2004/108/EG by the manufacturer

*2) Spark quenching/overload protection will be necessary using inductive loads.

Recommended circuit

Spark quenching and EMV intrinsically safe

1. Quick diode (D) with t_v ≤ 200 ns, parallel to inductive load.

2. RC link in parallel to load in parallel to switching contact.

Dimensioning principles:

R_L in Ω ≈ 0,2 x R_{Load} in Ω

C in [μF] ≈ I_{Load} in [A]

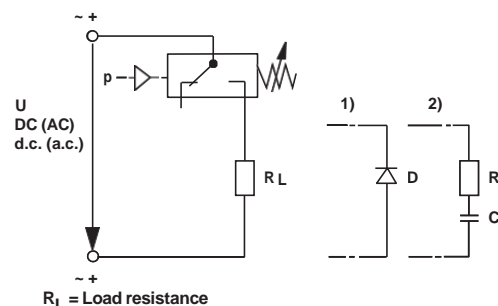

Drawings

1

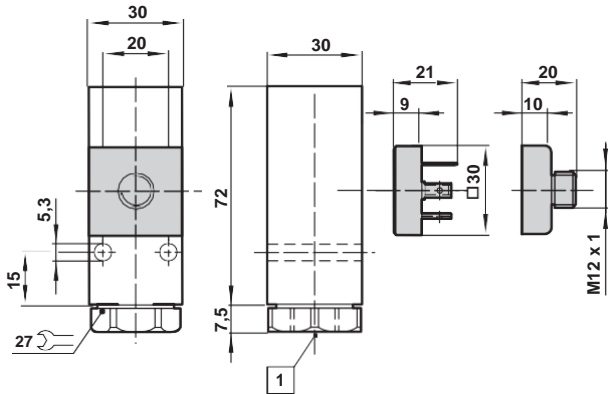

2

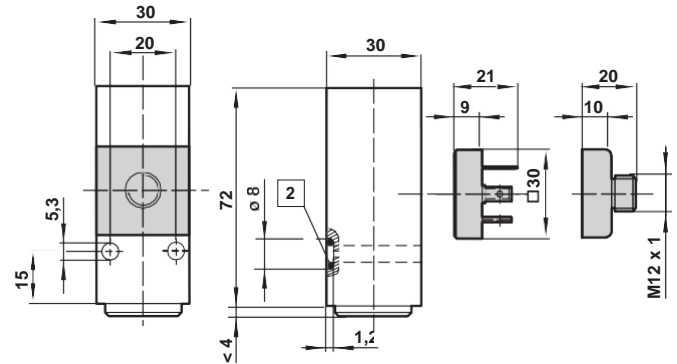

Dimensions in mm
Projection/First angle



3

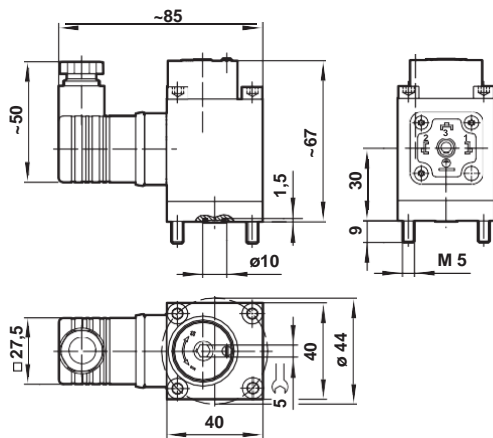

Adjustable switch point

After releasing the locking screw

Clockwise rotation = increasing switch point

Anti-clockwise rotation = decreasing the switch point

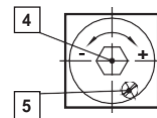

- 4 Locking screw
- 5 Switch point screw

- 1 Media port
- 2 O-ring 5 x 1,5

Pressure port reducing nipple

Model: 0574767 (brass)
0550083 (stainless steel)

el)

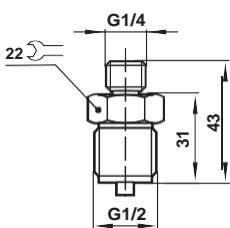

Surge damper

Model: 0574773 (brass)
0553258 (stainless steel)

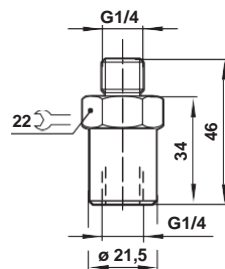

Cover

Model: 0554737 (plastic)

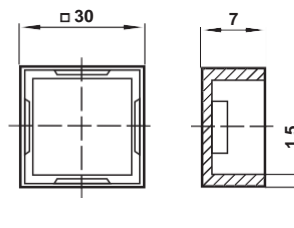

Warning

These products are intended for use in industrial compressed air systems only. Do not use these products where pressures and temperatures can exceed those listed under »**Technical features/ data**«.

Before using these products with fluids other than those specified, for non-industrial applications, life-support systems or other applications not within published specifications, consult Norgren Ltd.

Through misuse, age, or malfunction, components used in fluid power systems can fail in various modes.

The system designer is warned to consider the failure modes of all component parts used in fluid power systems and to provide adequate safeguards to prevent personal injury or damage to equipment in the event of such failure.

System designers must provide a warning to end users in the system instructional manual if protection against a failure mode cannot be adequately provided.

System designers and end users are cautioned to review specific warnings found in instruction sheets packed and shipped with these products.