

- NOTES:
1. ALL DIMENSIONS IN MM
 2. TERM. NOS. FOR REF. ONLY
 3. RATING: 3A @120VAC DR 28VDC
1A @250VAC
 4. CRIMP METAL RETAINING BRACKET
 5. 2002/95/EC (ROHS) COMPLIANT
 6. GENERAL TOLERANCE: X.XX=±0.4
X.XXX=±0.25

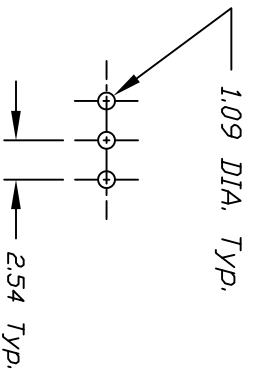

RECOMMEND P.C.B. LAYOUT

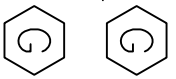
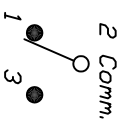
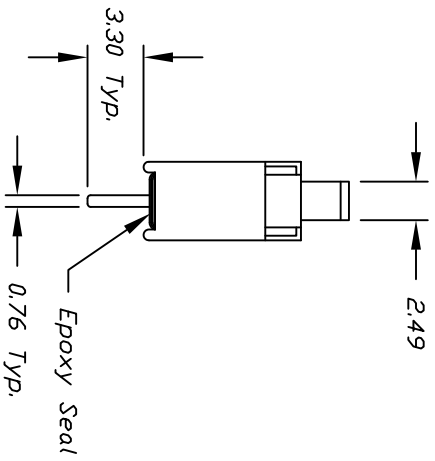
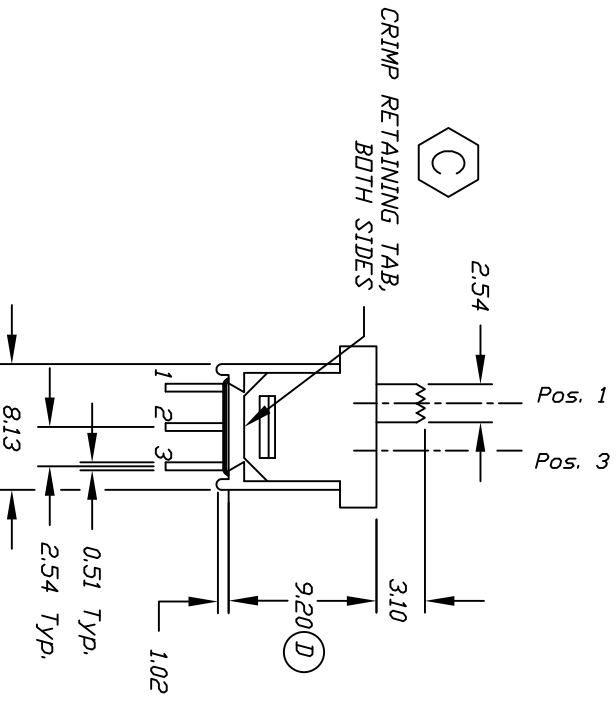

CIRCUIT: SPDT

CONTACT CONFIGURATION

SWITCH FUNCTION	
POS. 1	POS. 3
DN	DN
2-1	2-3

REV.	ECN	DESCRIPTION	DATE	CHK
G	20794	EDIT RATING, ADD TOLERANCE	10/11/12	EBP
F	15955	EDIT RATING	4/11/06	CT
E	15823	EDIT RATING	2/27/06	PH
D	15427	CHANGED FROM 8.79	10/21/05	PH
C		ADDED NOTES	7/5/05	JB
B		REVISED & REDRAWN		

TITLE		SCALE	DATE	DR	DWG	REV
500A SSP-1 M2 Q E		2:1	12/12/97	MM	T551002	G



THE INFORMATION CONTAINED IN THIS DOCUMENT IS PROPRIETARY TO E-SWITCH AND IS NOT TO BE COPIED OR TRANSFERRED