

L80225 10/100 MbpsTX/10BT Ethernet Physical Layer Device (PHY) Technical Manual

Features

- Single Chip 100Base-TX /10Base-T physical layer solution
- Dual Speed - 10/100 Mbps
- Half and Full Duplex
- MII interface to Ethernet Controller
- MI interface for configuration & status
- Optional Repeater Interface
- AutoNegotiation: 10/100, Full/Half Duplex
- Meets all applicable IEEE 802.3 standards
- Advertisement control through pins
- Adaptive Equalizer
- On-chip wave shaping - no external filters required
- Baseline Wander Correction
- LED outputs
 - Link
 - Activity
 - Collision
 - Full Duplex
 - 10/100
- Few external components
- 3.3 V supply with 5 V tolerant I/O
- 44 PLCC

Contents	
Description 2 Pin Description 4 Block Diagram 8 Functional Description 9 Register Description 43	Application Information 51 Specifications 65 Ordering Information 84 Revision History 84 Surface Mount Packages 87

Note: Check for the latest revision of this document before starting any designs. This document is available on the Web, at www.lsillogic.com

Description

The L80225 is a highly integrated analog interface IC for twisted pair Ethernet applications. The L80225 can be configured for either (100Base-TX) or 10 Mbps (10Base-T) Ethernet operation.

The L80225 consists of 4B5B/Manchester encoder/decoder, scrambler/descrambler, transmitter with wave shaping and output driver, twisted pair receiver with on chip equalizer and baseline wander correction, clock and data recovery, AutoNegotiation, controller interface (MII), and serial port (MI).

The addition of internal output waveshaping circuitry and on-chip filters eliminates the need for external filters normally required in 100Base-TX and 10Base-T applications.

The L80225 can automatically configure itself for 100 or 10 Mbps and Full or Half Duplex operation with the on-chip AutoNegotiation algorithm.

The L80225 can access six 16-bit registers through the Management Interface (MI) serial port. These registers contain configuration inputs, status outputs, and device capabilities.

The L80225 is ideal as a media interface for 100Base-TX/ 10Base-T adapter cards, motherboards, repeaters, switching hubs, and external PHYs.

The L80225 operates from a single 3.3V supply. All inputs and outputs are 5V tolerant and will directly interface to other 5V devices.

Pin Configuration

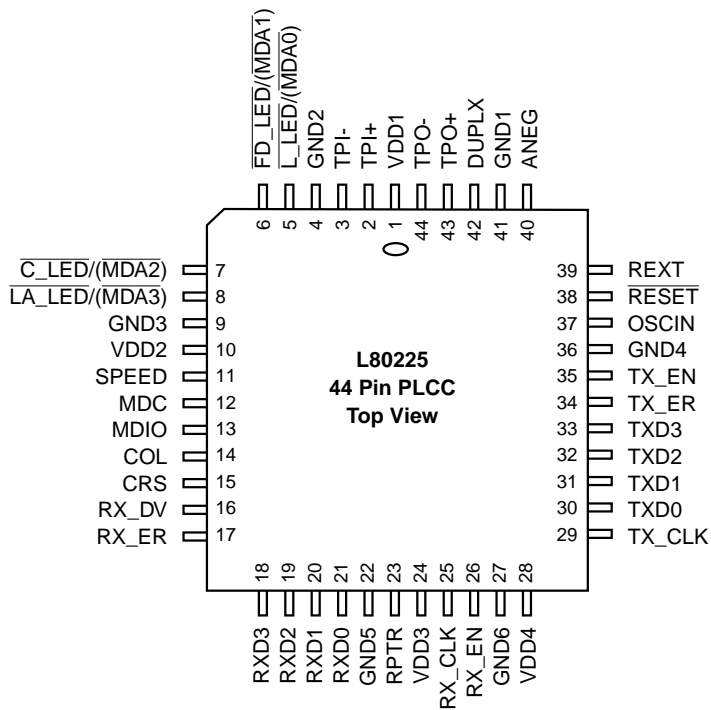

1 Pin Description

Pin Description

Pin #	Pin Name	I/O	Description
28 24 10 1	VDD4 VDD3 VDD2 VDD1	—	Positive Supply. 3.3 V \pm 5% Volts
27 22 36 9 4 41	GND6 GND5 GND4 GND3 GND2 GND1	—	Ground. 0 V
43	TPO+	O	Twisted Pair Transmit Output, Positive.
44	TPO -	O	Twisted Pair Transmit Output, Negative.
2	TPI+	I	Twisted Pair Receive Input, Positive.
3	TPI -	I	Twisted Pair Receive Input, Negative.
39	REXT	—	Transmit Current Set. An external resistor connected between this pin and GND will set the output current for the TP and FX transmit outputs.
37	OSCIN	I	Clock Oscillator Input. There must be either a 25 MHz crystal between this pin and GND or a 25 MHz clock applied to this pin. TX_CLK output is generated from this input.
29	TX_CLK	O	Transmit Clock Output. This controller interface output provides a clock to an external controller. Transmit data from the controller on TXD, TX_EN, and TX_ER is clocked in on rising edges of TX_CLK and OSCIN.
35	TX_EN	I	Transmit Enable Input. This controller interface input has to be asserted active high to indicate that data on TXD and TX_ER is valid, and it is clocked in on rising edges of TX_CLK and OSCIN.
33 32 31 30	TXD3 TXD2 TXD1 TXD0	I	Transmit Data Input. These controller interface inputs contain input nibble data to be transmitted on the TP outputs, and they are clocked in on rising edges of TX_CLK and OSCIN when TX_EN is asserted.
34	TX_ER	I	Transmit Error Input. This controller interface input causes a special pattern to be transmitted on the twisted pair outputs in place of normal data, and it is clocked in on rising edges of TX_CLK when TX_EN is asserted.

Pin Description (Cont.)

Pin #	Pin Name	I/O	Description
25	RX_CLK	O	Receive Clock Output. This controller interface output provides a clock to an external controller. Receive data on RXD, RX_DV, and RX_ER is clocked out on falling edges of RX_CLK.
15	CRS	O	Carrier Sense Output. This controller interface output is asserted active high when valid data is detected on the receive twisted pair inputs, and it is clocked out on falling edges of RX_CLK.
16	RX_DV	O	Receive Data Valid Output. This controller interface output is asserted active high when valid decoded data is present on the RXD outputs, and it is clocked out on falling edges of RX_CLK.
18 19 20 21	RXD3 RXD2 RXD1 RXD0	O	Receive Data Output. These controller interface outputs contain receive nibble data from the TP input, and they are clocked out on falling edges of RX_CLK.
17	RX_ER	O	Receive Error Output. This controller interface output is asserted active high when a coding or other specified errors are detected on the receive twisted pair inputs and it is clocked out on falling edges of RX_CLK.
14	COL	O	Collision Output. This controller interface output is asserted active high when a collision between transmit and receive data is detected.
12	MDC	I	Management Interface (MI) Clock Input. This MI clock shifts serial data into and out of MDIO on rising edges.
13	MDIO	I/O	Management Interface (MI) Data Input/Output. This bidirectional pin contains serial MI data that is clocked in and out on rising edges of the MDC clock.
8	$\overline{\text{LA_LED}}$ / (MDA3)	I/O O.D. Pullup	Link + Activity LED/Management Interface Address Input. This pin indicates the occurrence of Link or Activity. It can drive an LED from VDD. 0 = Link Detect Blink = Link Detect and Activity 1 = No Link Detect During powerup or reset, this pin is high impedance and its value is latched in as the physical device address MDA3 for the MI serial port.
7	$\overline{\text{C_LED}}$ / (MDA2)	I/O O.D. Pullup	Collision LED Output/Management Interface Address Input. This pin indicates the occurrence of a Collision. It can drive an LED from VDD. 0 = Collision Detect 1 = No Collision During powerup or reset, this pin is high impedance and the value on this pin is latched in as the physical device address MDA2 for the MI serial port.

Pin Description (Cont.)

Pin #	Pin Name	I/O	Description
6	$\overline{\text{FD_LED}}$ / (MDA1)	I/O Pullup	Full Duplex LED Output/Management Interface Address Input. This pin is a Full Duplex Detect output. It can drive an LED from VDD. 0 = Full Duplex Mode Detect with Link Pass 1 = Half Duplex During powerup or reset, this pin is high impedance and its value is latched in as the physical address device address MDA1 for the MI serial port.
5	$\overline{\text{L_LED}}$ / (MDA0)	I/O Pullup	Link LED Output/Management Interface Address Input. This pin is a 10/100 Mbps Detect output. It can drive an LED from VDD. 0 = 100 Mbit Mode Detected with Link Pass 1 = 10 Mbit Mode Detected During powerup or reset, this pin is high impedance and the value on this pin is latched in as the address MDA0 for the MI serial port.
26	RX_EN	I	Receive Enable Input 1 = All Outputs Enabled 0 = Receive Controller Outputs are High Impedance (RX_CLK, RXD[3:0], RX_DV, RX_ER, COL).
23	RPTR	I	Repeater Mode Enable Input. 1 = Repeater Mode Enabled 0 = Normal Operation
11	SPEED	I	Speed Select Input. This input pin selects 10/100 Mbps operation when pin ANEG = 0. When ANEG = 1, this pin controls the 10/100 advertisement abilities of the device. 1 = 100 Mbps 0 = 10 Mbps
42	DPLX	I	Full/Half Duplex Select Input. This input pin selects Half/Full Duplex operation when pin ANEG = 0. When ANEG = 1, this pin controls the Half/Full Duplex advertisement abilities. 1 = Full Duplex 0 = Half Duplex

Pin Description (Cont.)

Pin #	Pin Name	I/O	Description																																				
40	ANEG	I	AutoNegotiation Enable Input. 1 = AutoNegotiation On 0 = AutoNegotiation Off																																				
			<table border="1"> <thead> <tr> <th>ANEG</th> <th>Speed</th> <th>Duplx</th> <th></th> </tr> </thead> <tbody> <tr> <td>0</td> <td>0</td> <td>0</td> <td>Forced 10 Mbit Half Duplex Mode</td> </tr> <tr> <td>0</td> <td>0</td> <td>1</td> <td>Forced 10 Mbit Full Duplex Mode</td> </tr> <tr> <td>0</td> <td>1</td> <td>0</td> <td>Forced 100 Mbit Half Duplex Mode</td> </tr> <tr> <td>0</td> <td>1</td> <td>1</td> <td>Forced 100 Mbit Full Duplex Mode</td> </tr> <tr> <td>1</td> <td>0</td> <td>0</td> <td>AutoNegotiate and Advertise 10 M Half Duplex only</td> </tr> <tr> <td>1</td> <td>0</td> <td>1</td> <td>AutoNegotiate and Advertise 10 M Half/Full Duplex only</td> </tr> <tr> <td>1</td> <td>1</td> <td>0</td> <td>AutoNegotiate and Advertise all the capabilities Mode (Default). Note: To control advertisement through the register, these three pins must be configured in this default mode.</td> </tr> <tr> <td>1</td> <td>1</td> <td>1</td> <td>AutoNegotiate and Advertise 10/100 M Half Duplex only</td> </tr> </tbody> </table>	ANEG	Speed	Duplx		0	0	0	Forced 10 Mbit Half Duplex Mode	0	0	1	Forced 10 Mbit Full Duplex Mode	0	1	0	Forced 100 Mbit Half Duplex Mode	0	1	1	Forced 100 Mbit Full Duplex Mode	1	0	0	AutoNegotiate and Advertise 10 M Half Duplex only	1	0	1	AutoNegotiate and Advertise 10 M Half/Full Duplex only	1	1	0	AutoNegotiate and Advertise all the capabilities Mode (Default). Note: To control advertisement through the register, these three pins must be configured in this default mode.	1	1	1	AutoNegotiate and Advertise 10/100 M Half Duplex only
			ANEG	Speed	Duplx																																		
			0	0	0	Forced 10 Mbit Half Duplex Mode																																	
			0	0	1	Forced 10 Mbit Full Duplex Mode																																	
			0	1	0	Forced 100 Mbit Half Duplex Mode																																	
			0	1	1	Forced 100 Mbit Full Duplex Mode																																	
			1	0	0	AutoNegotiate and Advertise 10 M Half Duplex only																																	
			1	0	1	AutoNegotiate and Advertise 10 M Half/Full Duplex only																																	
1	1	0	AutoNegotiate and Advertise all the capabilities Mode (Default). Note: To control advertisement through the register, these three pins must be configured in this default mode.																																				
1	1	1	AutoNegotiate and Advertise 10/100 M Half Duplex only																																				
38	$\overline{\text{RESET}}$	I Pullup	RESET Input 1 = Normal Operation 0 = Device Reset																																				

2 Block Diagram

Figure 1 Block Diagram

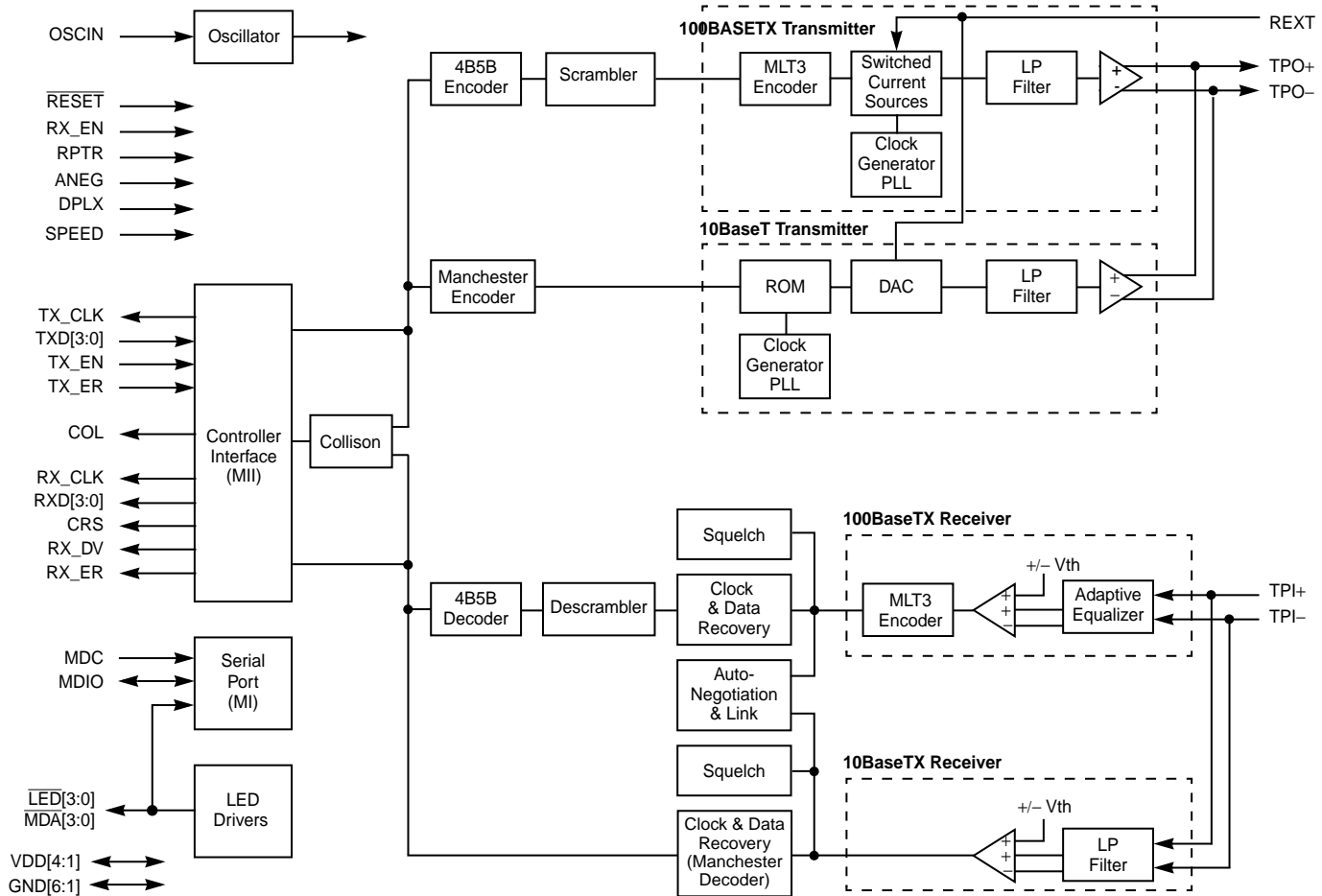

3 Functional Description

3.1 General

The L80225 is a complete 100/10 Mbps Ethernet Media Interface IC. The L80225 has nine main sections: controller interface, encoder, decoder, scrambler, descrambler, clock and data recovery, twisted pair transmitter, twisted pair receiver, and MI serial port. A block diagram is shown in [Figure 1](#).

The L80225 can operate as a 100Base-TX device (hereafter referred to as 100 Mbps mode) or as a 10Base-T device (hereafter referred to as 10 Mbps mode). The difference between the 100 Mbps mode and the 10 Mbps mode is data rate, signaling protocol, and allowed wiring. The 100 Mbps TX mode uses two pairs of category 5 or better UTP or STP twisted pair cable with 4B5B encoded, scrambled, and MLT-3 coded 62.5 MHz ternary data to achieve a throughput of 100 Mbps. The 10 Mbps mode uses two pairs of category 3 or better UTP or STP twisted pair cable with Manchester encoded, 10 MHz binary data to achieve a 10 Mbps throughput. The data symbol format on the twisted pair cable for the 100 and 10 Mbps modes is defined in IEEE 802.3 specifications and shown in [Figure 2](#).

On the transmit side for 100 Mbps TX operation, data is received on the controller interface from an external Ethernet controller per the format shown in [Figure 3](#). The data is then sent to the 4B5B encoder for formatting. The encoded data is then sent to the scrambler. The scrambled and encoded data is then sent to the TP transmitter. The TP transmitter converts the encoded and scrambled data into MLT-3 ternary format, preshapes the output, and drives the twisted pair cable.

Figure 2 TX/10BT Frame Format

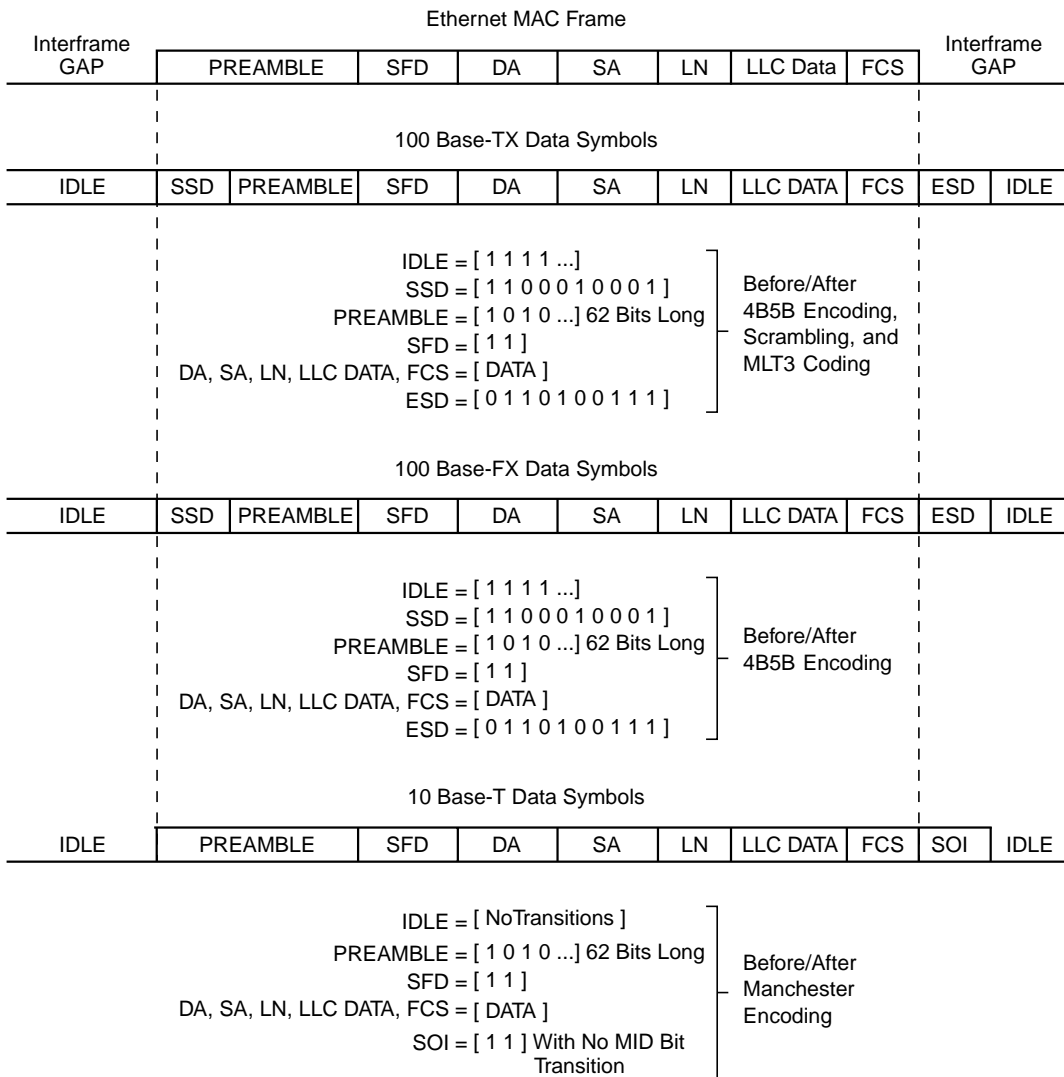

On the receive side for 100 Mbps TX operation, the twisted pair receiver receives incoming encoded and scrambled MLT-3 data from the twisted pair cable, removes any high frequency noise, equalizes the input signal to compensate for the effects of the cable, equalizes the data with a squelch algorithm, and converts the data from MLT-3 coded twisted pair levels to internal digital levels. The output of the twisted pair receiver then goes to a clock and data recovery block which recovers a clock from the incoming data, uses the clock to latch in valid data into the device, and converts the data back to NRZ format. The NRZ data is then unscrambled and decoded by the 4B5B decoder and descrambler, respectively, and outputted to an external Ethernet controller by the controller interface.

10 Mbps operation is similar to the 100 Mbps TX operation except, (1) there is no scrambler/descrambler, (2) the encoder/decoder is Manchester instead of 4B5B, (3) the data rate is 10 Mbps instead of 100 Mbps, and (4) the twisted pair symbol data is two level Manchester instead of ternary MLT-3.

The Management Interface, (hereafter referred to as the MI serial port), is a two pin bidirectional link through which configuration inputs can be set and status outputs can be read.

Each block plus the operating modes are described in more detail in the following sections. Since the L80225 can operate as either a 100Base-TX or a 10Base-T device, each of the following sections describes the performance of the respective section in both the 100 and 10 Mbps modes.

3.2 Differences between 80220/80221, L80225, and 80223

Table 1 80221, L80225, and 80223

Difference	80221	L80225	80223
Power Supply	5V	3.3V	3.3V
RESET Pin	No	Yes	Yes
FX Interface	No	Yes	Yes
Transmit Xfmr. Winding Ratio	2:1	1:1	1:1
T4 Interface	Yes	No	No
Speed Pin	No	Yes	Yes
Duplx Pin	No	Yes	Yes
Hardware Advertisement Control	No	Yes	No
Registers 16-20	Yes	No	Yes

3.3 Controller Interface

3.3.1 General

The L80225 has two interfaces to an external controller: Media Independent Interface (referred to as the MII).

3.3.2 MII - 100 Mbps

The MII is a nibble wide packet data interface defined in IEEE 802.3 and shown in [Figure 3](#). The L80225 meets all the MII requirements outlined in IEEE 802.3. The L80225 can directly connect, without any external logic, to any Ethernet controllers or other devices which also complies with the IEEE 802.3 MII specifications. The MII frame format is shown in [Figure 3](#).

The MII consists of eighteen signals: four transmit data bits (TXD[3:0]), transmit clock (TX_CLK), transmit enable (TX_EN), transmit error (TX_ER), four receive data bits (RXD[3:0]), receive clock (RX_CLK), carrier sense (CRS), receive data valid (RX_DV), receive data error

(RX_ER), and collision (COL). The transmit and receive clocks operate at 25 MHz in 100 Mbps mode.

On the transmit side, the TX_CLK output runs continuously at 25 MHz. When no data is to be transmitted, TX_EN has to be deasserted. While TX_EN is deasserted, TX_ER and TXD[3:0] are ignored and no data is clocked into the device. When TX_EN is asserted on the rising edge of TX_CLK, data on TXD[3:0] is clocked into the device on rising edges of the TX_CLK output clock. TXD[3:0] input data is nibble wide packet data whose format needs to be the same as specified in IEEE 802.3 and shown in [Figure 3](#). When all data on TXD[3:0] has been latched into the device, TX_EN has to be deasserted on the rising edge of TX_CLK.

TX_ER is also clocked in on rising edges of the TX_CLK clock. TX_ER is a transmit error signal which, when asserted, will substitute an error nibble in place of the normal data nibble that was clocked in on TXD[3:0]. The error nibble is defined to be the /H/ symbol, which is defined in IEEE 802.3 and shown in [Table 2](#).

Since OSCIN input clock generates the TX_CLK output clock, TXD[3:0], TX_EN, and TX_ER are also clocked in on rising edges of OSCIN.

On the receive side, as long as a valid data packet is not detected, CRS and RX_DV are deasserted and RXD[3:0] is held low. When the start of packet is detected, CRS and RX_DV are asserted on falling edge of RX_CLK. The assertion of RX_DV indicates that valid data is clocked out on RXD[3:0] on falling edges of the RX_CLK clock. The RXD[3:0] data has the same frame structure as the TXD[3:0] data and is specified in IEEE 802.3 and shown in [Figure 3](#). When the end of packet is detected, CRS and RX_DV are deasserted, and RXD[3:0] is held low. CRS and RX_DV also stay deasserted if the device is in the Link Fail State.

RX_ER is a receive error output which is asserted when certain errors are detected on a data nibble. RX_ER is asserted on the falling edge of RX_CLK for the duration of that RX_CLK clock cycle during which the nibble containing the error is being outputted on RXD[3:0].

The collision output, COL, is asserted whenever the collision condition is detected.

3.3.3 MII - 10 Mbps

10 Mbps operation is identical to the 100 Mbps operation except, (1) TX_CLK and RX_CLK clock frequency is reduced to 2.5 MHz, (2) TX_ER is ignored, (3) RX_ER is disabled and always held low, and (4) receive operation is modified as follows: On the receive side, when the squelch circuit determines that invalid data is present on the TP inputs, the receiver is idle. During idle, RX_CLK follows TX_CLK, RXD[3:0] is held low, and CRS and RX_DV are deasserted. When a start of packet is detected on the TP receive inputs, CRS is asserted and the clock recovery process starts on the incoming TP input data. After the receive clock has been recovered from the data, the RX_CLK is switched over to the recovered clock and the data valid signal RX_DV is asserted on a falling edge of RX_CLK. Once RX_DV is asserted, valid data is clocked out on RXD[3:0] on falling edges of the RX_CLK clock. The RXD[3:0] data has the same packet structure as the TXD[3:0] data and is formatted on RXD[3:0] as specified in IEEE 802.3 and shown in [Figure 3](#). When the end of packet is detected, CRS and RX_DV are deasserted. CRS and RX_DV also stay deasserted as long as the device is in the Link Fail State.

3.3.4 MII Disable

The MII inputs and outputs can be disabled by setting the MII disable bit in the MI serial port Control register. When the MII is disabled, the MII inputs are ignored, the MII outputs are placed in high impedance state, and the TP output is high impedance.

If the MI address lines, $\overline{\text{MDA}}[3:0]$, are pulled high during reset or powerup, the L80225 powers up and resets with the MII disabled. Otherwise, the L80225 powers up and resets with the MII enabled.

3.3.5 Receive Output High Impedance Control

The RX_EN pin can be configured to be RX_EN, a high impedance control for the receive controller output signals, by setting the R/J Configuration select bit in the MI serial port Configuration 2 register. When this pin is configured to be RX_EN and is deasserted active low, the following outputs will be placed in the high impedance state: RX_CLK, RXD[3:0], RX_DV, RX_ER, and COL.

3.3.6 TX_EN to CRS Loopback Disable

The internal TX_EN to CRS loopback can be disabled by appropriately setting the TXEN to CRS loopback disable bit in the MI serial port Configuration 1 register.

3.4 Encoder

3.4.1 4B5B Encoder - 100 Mbps

100Base-TX requires that the data be 4B5B encoded. 4B5B coding converts the 4-Bit data nibbles into 5-Bit data code words. The mapping of the 4B nibbles to the 5B code words is specified in IEEE 802.3 and shown in [Table 2](#). The 4B5B encoder on the L80225 takes 4B nibbles from the controller interface, converts them into 5B words according to [Table 2](#), and sends the 5B words to the scrambler. The 4B5B encoder also substitutes the first 8 bits of the preamble with the SSD delimiters (a.k.a. /J/K/ symbols) and adds an ESD delimiter (a.k.a. /T/R/ symbols) to the end of every packet, as defined in IEEE 802.3 and shown in [Figure 2](#). The 4B5B encoder also fills the period between packets, called the idle period, with the a continuous stream of idle symbols, as shown in [Figure 2](#).

3.4.2 Manchester Encoder - 10 Mbps

The Manchester encoding process combines clock and NRZ data such that the first half of the data bit contains the complement of the data, and the second half of the data bit contains the true data, as specified in IEEE 802.3. This guarantees that a transition always occurs in the middle of the bit cell. The Manchester encoder on the L80225 converts the 10 Mbps NRZ data from the controller interface into a Manchester Encoded data stream for the TP transmitter and adds a start of idle pulse (SOI) at the end of the packet as specified in IEEE 802.3 and shown in [Figure 2](#). The Manchester encoding process is only done on actual packet data,

and the idle period between packets is not Manchester encoded and filled with link pulses.

Table 2 4B/5B Symbol Mapping

Symbol Name	Description	5B Code	4B Code
0	Data 0	11110	0000
1	Data 1	01001	0001
2	Data 2	10100	0010
3	Data 3	10101	0011
4	Data 4	01010	0100
5	Data 5	01011	0101
6	Data 6	01110	0110
7	Data 7	01111	0111
8	Data 8	10010	1000
9	Data 9	10011	1001
A	Data A	10110	1010
B	Data B	10111	1011
C	Data C	11010	1100
D	Data D	11011	1101
E	Data E	11100	1110
F	Data F	11101	1111
I	Idle	11111	0000
J	SSD #1	11000	0101
K	SSD #2	10001	0101
T	ESD #1	01101	0000
R	ESD #2	00111	0000

Table 2 4B/5B Symbol Mapping (Cont.)

Symbol Name	Description	5B Code	4B Code
H	Halt	00100	Undefined
---	Invalid codes	All others ¹	0000 ¹

1. These 5B codes are not used. For decoder, these 5B codes are decoded to 4B 0000. For encoder, 4B 0000 is encoded to 5B 11110, as shown in symbol Data 0.

3.5 Decoder

3.5.1 4B5B Decoder - 100 Mbps

Since the TP input data is 4B5B encoded on the transmit side, it must also be decoded by the 4B5B decoder on the receive side. The mapping of the 5B nibbles to the 4B code words is specified in IEEE 802.3 and shown in [Table 2](#). The 4B45 decoder on the L80225 takes the 5B code words from the descrambler, converts them into 4B nibbles per [Table 2](#), and sends the 4B nibbles to the controller interface. The 4B5B decoder also strips off the SSD delimiter (a.k.a. /J/K/ symbols) and replaces them with two 4B Data 5 nibbles (a.k.a. /5/ symbol), and strips off the ESD delimiter (a.k.a. /T/R/ symbols) and replaces it with two 4B Data 0 nibbles (a.k.a. // symbol), per IEEE 802.3 specifications and shown in [Figure 2](#).

The 4B5B decoder detects SSD, ESD and, codeword errors in the incoming data stream as specified in IEEE 802.3. These errors are indicated by asserting RX_ER output while the errors are being transmitted across RXD[3:0], and they are also indicated in the serial port by setting SSD, ESD, and codeword error bits in the MI serial port Status Output register.

3.5.2 Manchester Decoder - 10 Mbps

In Manchester coded data, the first half of the data bit contains the complement of the data, and the second half of the data bit contains the true data. The Manchester decoder in the L80225 converts the Manchester encoded data stream from the TP receiver into NRZ data for the controller interface by decoding the data and stripping off the SOI

pulse. Since the clock and data recovery block has already separated the clock and data from the TP receiver, the Manchester decoding process to NRZ data is inherently performed by that block.

3.6 Clock and Data Recovery

3.6.1 Clock Recovery - 100 Mbps

Clock recovery is done with a PLL. If there is no valid data present on the TP inputs, the PLL is locked to the 25 MHz TX_CLK. When valid data is detected on the TP inputs with the squelch circuit and when the adaptive equalizer has settled, the PLL input is switched to the incoming data on the TP input. The PLL then recovers a clock by locking onto the transitions of the incoming signal from the twisted pair wire. The recovered clock frequency is a 25 MHz nibble clock, and that clock is outputted on the controller interface signal RX_CLK.

3.6.2 Data Recovery - 100 Mbps

Data recovery is performed by latching in data from the TP receiver with the recovered clock extracted by the PLL. The data is then converted from a single bit stream into nibble wide data word according to the format shown in [Figure 3](#).

3.6.3 Clock Recovery - 10 Mbps

The clock recovery process for 10 Mbps mode is identical to the 100 Mbps mode except, (1) the recovered clock frequency is 2.5 MHz nibble clock, (2) the PLL is switched from TX_CLK to the TP input when the squelch indicates valid data, (3) The PLL takes up to 12 transitions (bit times) to lock onto the preamble, so some of the preamble data symbols are lost, but the clock recovery block recovers enough preamble symbols to pass at least 6 nibbles of preamble to the receive controller interface as shown in [Figure 3](#).

3.6.4 Data Recovery - 10 Mbps

The data recovery process for 10 Mbps mode is identical to the 100 Mbps mode. As mentioned in the Manchester Decoder section, the data recovery process inherently performs decoding of Manchester encoded data from the TP inputs.

3.7 Scrambler

3.7.1 100 Mbps

100Base-TX requires scrambling to reduce the radiated emissions on the twisted pair. The L80225 scrambler takes the encoded data from the 4B5B encoder, scrambles it per the IEEE 802.3 specifications, and sends it to the TP transmitter.

3.7.2 10 Mbps

A scrambler is not used in 10 Mbps mode.

3.8 Descrambler

3.8.1 100 Mbps

The L80225 descrambler takes the scrambled data from the data recovery block, descrambles it per the IEEE 802.3 specifications, aligns the data on the correct 5B word boundaries, and sends it to the 4B5B decoder.

The algorithm for synchronization of the descrambler is the same as the algorithm outlined in the IEEE 802.3 specification. Once the descrambler is synchronized, it will maintain synchronization as long as enough descrambled idle pattern 1's are detected within a given interval. To stay in synchronization, the descrambler needs to detect at least 25 consecutive descrambled idle pattern 1's in a 1 ms interval. If 25 consecutive descrambled idle pattern 1's are not detected within the 1 ms interval, the descrambler goes out of synchronization and restarts the synchronization process.

If the descrambler is in the unsynchronized state, the descrambler loss of synchronization detect bit is set in the MI serial port Status Output register to indicate this condition. Once this bit is set, it will stay set until the descrambler achieves synchronization.

3.8.2 10 Mbps

A descrambler is not used in 10 Mbps mode.

3.9 Twisted Pair Transmitter

3.9.1 Transmitter - 100 Mbps

The TX transmitter consists of an MLT-3 encoder, waveform generator, and line driver.

The MLT-3 encoder converts the NRZ data from the scrambler into a three level MLT-3 code required by IEEE 802.3. MLT-3 coding uses three levels and converts 1's to transitions between the three levels, and converts 0's to no transitions or changes in level.

The purpose of the waveform generator is to shape the transmit output pulse. The waveform generator takes the MLT-3 three level encoded waveform and uses an array of switched current sources to control the rise/fall time and level of the signal at the output. The output of the switched current sources then goes through a low pass filter in order to "smooth" the current output and remove any high frequency components. In this way, the waveform generator preshapes the output waveform transmitted onto the twisted pair cable to meet the pulse template requirements outlined in IEEE 802.3. The waveform generator eliminates the need for any external filters on the TP transmit output.

The line driver converts the shaped and smoothed waveform to a current output that can drive 100 meters of category 5 unshielded twisted pair cable or 150 Ohm shielded twisted pair cable.

3.9.2 Transmitter - 10 Mbps

The transmitter operation in 10 Mbps mode is much different from the 100 Mbps transmitter. Even so, the transmitter still consists of a waveform generator and line driver.

The purpose of the waveform generator is to shape the output transmit pulse. The waveform generator consists of a ROM, DAC, clock generator, and filter. The DAC generates a stair-stepped representation of the desired output waveform. The stairstepped DAC output then goes through a low pass filter in order to "smooth" the DAC output and remove any high frequency components. The DAC values are determined from the ROM outputs; the ROM contents are chosen to shape the pulse to the desired template and are clocked into the DAC at high speed by the clock generator. In this way, the waveform generator preshapes the

output waveform to be transmitted onto the twisted pair cable to meet the pulse template requirements outlined in IEEE 802.3 Clause 14 and also shown in [Figure 4](#). The waveshaper replaces and eliminates external filters on the TP transmit output.

The line driver converts the shaped and smoothed waveform to a current output that can drive 100 meters of category 3/4/5 100 Ohm unshielded twisted pair cable or 150 Ohm shielded twisted pair cable tied directly to the TP output pins without any external filters. During the idle period, no output signal is transmitted on the TP outputs (except link pulse).

3.9.3 STP (150 Ohm) Cable Mode

The transmitter can be configured to drive 150 Ohm shielded twisted pair cable. The STP mode can be selected by appropriately setting the cable type select bit in the MI serial port Configuration 1 register. When STP mode is enabled, the output current is automatically adjusted to comply with IEEE 802.3 levels.

3.9.4 Activity Indication

The $\overline{\text{LA_LED}}$ indicates the combination of link detect and activity. Link detect 10 or 100 MB causes this LED to stay ON and the detection of activity causes the LED to blink whenever activity is detected. The LED goes low for 100 ms every time a transmit or receive packet activity is detected.

The $\overline{\text{LA_LED}}$ output is an open drain with a pullup resistor and can drive an LED from VDD or can drive another digital input.

3.10 Twisted Pair Receiver

3.10.1 Receiver - 100 Mbps

The TX receiver detects input signals from the twisted pair input and converts it to a digital data bit stream ready for clock and data recovery. The receiver can reliably detect data from a 100Base-TX compliant transmitter that has been passed through 0-100 meters of 100 Ohm category 5 UTP or 150 Ohm STP.

The TX receiver consists of an adaptive equalizer, baseline wander correction circuit, comparators, and MLT-3 decoder. The TP inputs first

go to an adaptive equalizer. The adaptive equalizer compensates for the low pass characteristic of the cable, and it has the ability to adapt and compensate for 0-100 meters of category 5, 100 Ohm UTP or 150 Ohm STP twisted pair cable. The baseline wander correction circuit restores the DC component of the input waveform that was removed by external transformers. The comparators convert the equalized signal back to digital levels and are used to qualify the data with the squelch circuit. The MLT-3 decoder takes the three level MLT-3 digital data from the comparators and converts it back to normal digital data to be used for clock and data recovery.

3.10.2 Receiver - 10 Mbps

The 10 Mbps receiver is able to detect input signals from the twisted pair cable that are within the template shown in [Figure 5](#). The inputs are biased by internal resistors. The TP inputs pass through a low pass filter designed to eliminate any high frequency noise on the input. The output of the receive filter goes to two different types of comparators, squelch and zero crossing. The squelch comparator determines whether the signal is valid, and the zero crossing comparator is used to sense the actual data transitions once the signal is determined to be valid. The output of the squelch comparator goes to the squelch circuit and is also used for link pulse detection, SOI detection, and reverse polarity detection; the output of the zero crossing comparator is used for clock and data recovery in the Manchester decoder.

3.10.3 TP Squelch - 100 Mbps

The squelch block determines if the TP input contains valid data. The 100 Mbps TP squelch is one of the criteria used to determine link integrity. The squelch comparators compare the TP inputs against fixed positive and negative thresholds, called squelch levels.

Figure 4 TP Output Voltage Template-10 Mbps

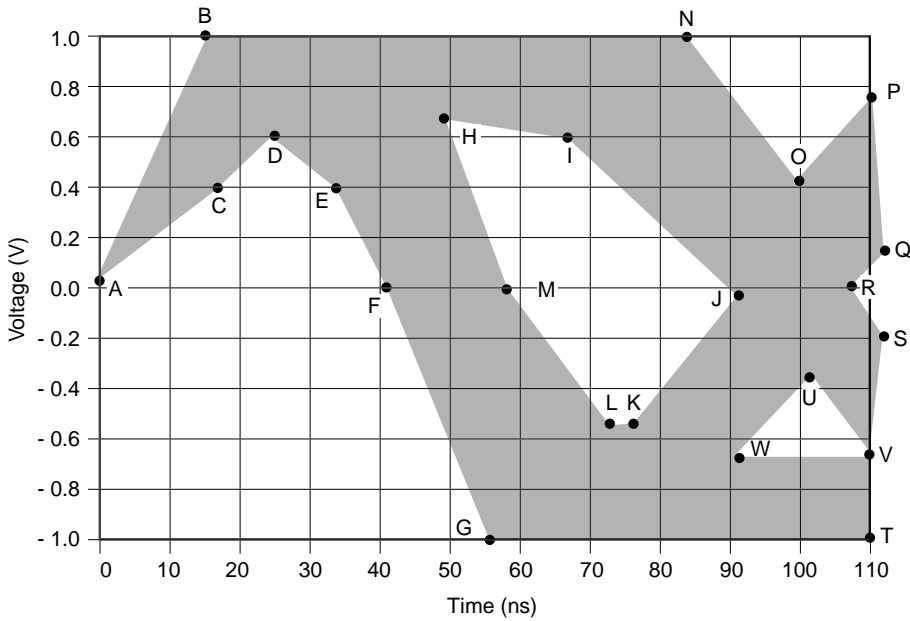

Reference	Time (ns) Internal MAU	Voltage (V)	Reference	Time (ns) Internal MAU	Voltage (V)
A	0	0	M	61	0
B	15	1.0	N	85	1.0
C	15	0.4	O	100	0.4
D	25	0.55	P	110	0.75
E	32	0.45	Q	111	0.15
F	39	0	R	111	0
G	57	-1.0	S	111	-0.15
H	48	0.7	T	110	-1.0
I	67	0.6	U	100	-0.3
J	89	0	V	110	-0.7
K	74	-0.55	W	90	-0.7
L	73	-0.55			

The output from the squelch comparator goes to a digital squelch circuit which determines if the receive input data on that channel is valid. If the data is invalid, the receiver is in the squelched state. If the input voltage

exceeds the squelch levels at least 4 times with alternating polarity within a 10 mS interval, the data is considered to be valid by the squelch circuit and the receiver now enters into the unsquelch state. In the unsquelch state, the receive threshold level is reduced by approximately 30% for noise immunity reasons and is called the unsquelch level. When the receiver is in the unsquelch state, then the input signal is deemed to be valid. The device stays in the unsquelch state until loss of data is detected. Loss of data is detected if no alternating polarity unsquelch transitions are detected during any 10 mS interval. When the loss of data is detected, the receive squelch is turned on again.

3.10.4 TP Squelch, 10 Mbps

The TP squelch algorithm for 10 Mbps mode is identical to the 100 Mbps mode except, (1) the 10 Mbps TP squelch algorithm is not used for link integrity but to sense the beginning of a packet, (2) the receiver goes into the unsquelch state if the input voltage exceeds the squelch levels for three bit times with alternating polarity within a 50-250 ns interval, (3) the receiver goes into the squelch state when idle is detected, (4) unsquelch detection has no affect on link integrity, link pulses are used for that in 10 Mbps mode, (5) start of packet is determined when the receiver goes into the unsquelch state and CRS is asserted, and (6) the receiver meets the squelch requirements defined in IEEE 802.3 Clause 14.

3.11 Collision

3.11.1 100 Mbps

Collision occurs whenever transmit and receive occur simultaneously while the device is in Half Duplex.

Collision is sensed whenever there is simultaneous transmission (packet transmission on TPO \pm) and reception (non idle symbols detected on TP input). When collision is detected, the COL output is asserted, TP data continues to be transmitted on twisted pair outputs, TP data continues to be received on twisted pair inputs, and internal CRS loopback is disabled. Once collision starts, CRS is asserted and stays asserted until the receive and transmit packets that caused the collision are terminated.

The collision function is disabled if the device is in the Full Duplex mode or is in the Link Fail state, or if the device is in the diagnostic loopback mode.

3.11.2 10 Mbps

Collision in 10 Mbps mode is identical to the 100 Mbps mode except, (1) reception is determined by the 10 Mbps squelch criteria, (2) RXD[3:0] outputs are forced to all 0's, (3) collision is asserted when the SQE test is performed, (4) collision is asserted when the jabber condition has been detected.

3.11.3 Collision Test

The controller interface collision signal, COL, can be tested by setting the collision test register bit in the MI serial port Control register. When this bit is set, TX_EN is looped back onto COL and the TP outputs are disabled.

3.11.4 Collision Indication

Collision is indicated through the $\overline{\text{CLED}}$ pin. This pin is asserted active low for 100 ms every time a collision occurs. The $\overline{\text{CLED}}$ output is open drain with pullup resistor and can drive an LED from Vdd or can drive another digital input.

3.12 Start of Packet

3.12.1 100 Mbps

Start of packet for 100 Mbps mode is indicated by a unique Start of Stream Delimiter (referred to as SSD). The SSD pattern consists of the two /J/K/ 5B symbols inserted at the beginning of the packet in place of the first two preamble symbols, as defined in IEEE 802.3 Clause 24 and shown in [Figure 2](#).

The transmit SSD is generated by the 4B5B encoder and the /J/K/ symbols are inserted by the 4B4B encoder at the beginning of the transmit data packet in place of the first two 5B symbols of the preamble, as shown in [Figure 2](#).

The receive pattern is detected by the 4B5B decoder by examining groups of 10 consecutive code bits (two 5B words) from the descrambler. Between packets, the receiver will be detecting the idle pattern, which is 5B // symbols. While in the idle state, CRS and RX_DV are deasserted.

If the receiver is in the idle state and 10 consecutive code bits from the receiver consist of the /J/K/ symbols, the start of packet is detected, data reception is begun, CRS and RX_DV are asserted, and /5/5/ symbols are substituted in place of the /J/K/ symbols.

If the receiver is in the idle state and 10 consecutive code bits from the receiver consist of a pattern that is neither /I/ I/ nor /J/K/ symbols but contains at least 2 non contiguous 0's, then activity is detected but the start of packet is considered to be faulty and a False Carrier Indication (also referred to as bad SSD) is signaled to the controller interface. When False Carrier is detected, then CRS is asserted, RX_DV remains deasserted, RXD[3:0]=1110 while RX_ER is asserted, and the bad SSD bit is set in the MI serial port Status Output register. Once a False Carrier Event is detected, the idle pattern (two /I/I/ symbols) must be detected before any new SSD's can be sensed.

Figure 5 Input Voltage Template-10Mbps

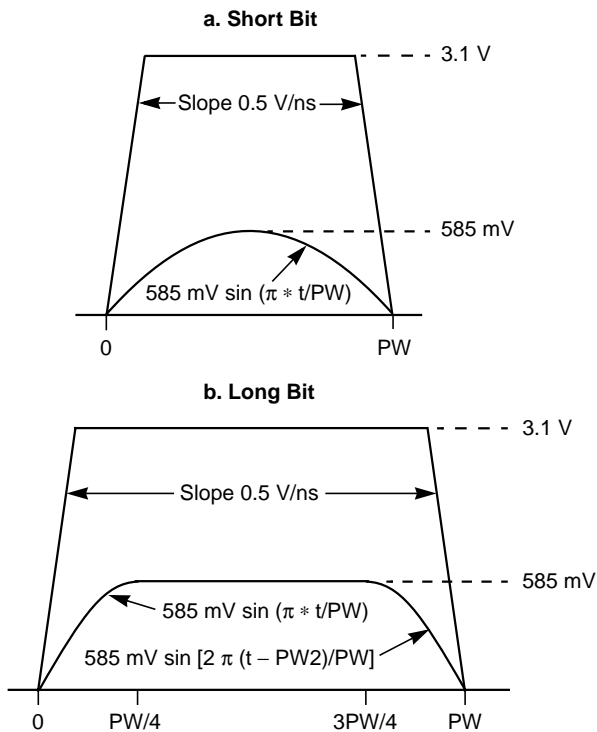

If the receiver is in the idle state and 10 consecutive code bits from the receiver consist of a pattern that is neither /I/ I/ nor /J/K/ symbols but does not contain at least 2 noncontiguous 0's, the data is ignored and the receiver stays in the idle state.

3.12.2 10 Mbps

Since the idle period in 10 Mbps mode is defined to be the period when no data is present on the TP inputs, then the start of packet for 10 Mbps mode is detected when valid data is detected by the TP squelch circuit. When start of packet is detected, CRS is asserted as described in the Controller Interface section. Refer to the TP squelch section for 10 Mbps mode for the algorithm for valid data detection.

3.13 End of Packet

3.13.1 100 Mbps

End of packet for 100 Mbps mode is indicated by the End of Stream Delimiter (referred to as ESD). The ESD pattern consists of the two /T/R/ 4B5B symbols inserted after the end of the packet, as defined in IEEE 802.3 Clause 24 and shown in [Figure 2](#).

The transmit ESD is generated by the 4B5B encoder and the /T/R/ symbols are inserted by the 4B5B encoder after the end of the transmit data packet, as shown in [Figure 2](#).

The receive ESD pattern is detected by the 4B5B decoder by examining groups of 10 consecutive code bits (two 5B words) from the descrambler during valid packet reception to determine if there is an ESD.

If the 10 consecutive code bits from the receiver during valid packet reception consist of the /T/R/ symbols, the end of packet is detected, data reception is terminated, CRS and RX_DV are asserted, and /I/I/ symbols are substituted in place of the /T/R/ symbols.

If 10 consecutive code bits from the receiver during valid packet reception do not consist of /T/R/ symbols but consist of /I/I/ symbols instead, then the packet is considered to have been terminated prematurely and abnormally. When this premature end of packet condition is detected, RX_ER is asserted for the nibble associated with the first /I/ symbol detected and then CRS and RX_DV are deasserted.

Premature end of packet condition is also indicated by setting the bad ESD bit in the MI serial port Status Output register.

3.13.2 10 Mbps

The end of packet for 10 Mbps mode is indicated with the SOI (Start of Idle) pulse. The SOI pulse is a positive pulse containing a Manchester code violation inserted at the end of every packet .

The transmit SOI pulse is generated by the TP transmitter and inserted at the end of the data packet after TX_EN is deasserted. The transmitted SOI output pulse at the TP output is shaped by the transmit waveshaper to meet the pulse template requirements specified in IEEE 802.3 Clause 14 and shown in [Figure 6](#).

The receive SOI pulse is detected by the TP receiver by sensing missing data transitions. Once the SOI pulse is detected, data reception is ended and CRS and RX_DV are deasserted.

3.14 Link Integrity & Autonegotiation

3.14.1 General

The L80225 can be configured to implement either the standard link integrity algorithms or the AutoNegotiation algorithm.

The standard link integrity algorithms are used solely to establish an active link to and from a remote device. There are different standard link integrity algorithms for 10 and 100 Mbps modes. The AutoNegotiation algorithm is used for two purposes: (1) To automatically configure the device for either 10/100 Mbps and Half/Full Duplex modes, and (2) to establish an active link to and from a remote device. The standard link integrity and AutoNegotiation algorithms are described below.

3.14.2 10Base-T Link Integrity Algorithm - 10Mbps

The L80225 uses the same 10Base-T link integrity algorithm that is defined in IEEE 802.3 Clause 14. This algorithm uses normal link pulses, referred to as NLP's and transmitted during idle periods, to determine if a device has successfully established a link with a remote device (called Link Pass state). The transmit link pulse meets the template defined in

IEEE 802.3 Clause 14 and shown in [Figure 7](#). Refer to IEEE 802.3 Clause 14 for more details if needed.

3.14.3 100Base-TX Link Integrity Algorithm -100Mbps

Since 100Base-TX is defined to have an active idle signal, then there is no need to have separate link pulses like those defined for 10Base-T. The L80225 uses the squelch criteria and descrambler synchronization algorithm on the input data to determine if the device has successfully established a link with a remote device (called Link Pass state). Refer to IEEE 802.3 for both of these algorithms for more details.

3.14.4 AutoNegotiation Algorithm

As stated previously, the AutoNegotiation algorithm is used for two purposes: (1) To automatically configure the device for either 10/100 Mbps and Half/Full Duplex modes, and (2) to establish an active link to and from a remote device. The AutoNegotiation algorithm is the same algorithm that is defined in IEEE 802.3 Clause 28. AutoNegotiation uses a burst of link pulses, called fast link pulses and referred to as FLP's, to pass up to 16 bits of signaling data back and forth between the L80225 and a remote device. The transmit FLP pulses meet the template specified in IEEE 802.3 and shown in [Figure 7](#). A timing diagram contrasting NLP's and FLP's is shown in [Figure 8](#).

The AutoNegotiation algorithm is initiated by any of the following events: (1) Powerup, (2) device reset, (3) AutoNegotiation reset, (4) AutoNegotiation enabled, or (5) a device enters the Link Fail State. Once a negotiation has been initiated, the L80225 first determines if the remote device has AutoNegotiation capability. If the remote device is not AutoNegotiation capable and is just transmitting either a 10Base-T or 100Base-TX signal, the L80225 will sense that and place itself in the correct mode. If the L80225 detects FLP's from the remote device, then the remote device is determined to have AutoNegotiation capability and the device then uses the contents of the MI serial port AutoNegotiation Advertisement register and FLP's to advertise its capabilities to a remote device. The remote device does the same, and the capabilities read back from the remote device are stored in the MI serial port AutoNegotiation Remote End Capability register. The L80225 negotiation algorithm then matches it's capabilities to the remote device's capabilities and determines what mode the device should be configured to according to the priority resolution algorithm defined in IEEE 802.3 Clause 28. Once

the negotiation process is completed, the L80225 then configures itself for either 10 or 100 Mbps mode and either Full or Half Duplex modes (depending on the outcome of the negotiation process), and it switches to either the 100Base-TX or 10Base-T link integrity algorithms (depending on which mode was enabled by AutoNegotiation). Refer to IEEE 802.3 Clause 28 for more details.

3.14.5 AutoNegotiation Outcome Indication

The outcome or result of the AutoNegotiation process is stored in the speed detect and duplex detect bits in the MI serial port Status Output register.

3.14.6 AutoNegotiation Status

The status of the AutoNegotiation process can be monitored by reading the AutoNegotiation acknowledgement bit in the MI serial port Status register. The MI serial port Status register contains a single AutoNegotiation acknowledgement bit, which indicates when an AutoNegotiation has been initiated and successfully completed.

3.14.7 AutoNegotiation Enable

The AutoNegotiation algorithm can be enabled (or restarted) by setting the AutoNegotiation enable bit in the MI serial port Control register or by asserting the ANEG pin. When the AutoNegotiation algorithm is enabled, the device halts all transmissions including link pulses for 1200- 1500 ms, enters the Link Fail State, and restarts the negotiation process. When the AutoNegotiation algorithm is disabled, the selection of 100 Mbps or 10 Mbps modes is determined by the speed select bit in the MI serial port Control register, and the selection of Half or Full Duplex is determined by the duplex select bit in the MI serial port Control register.

3.14.8 AutoNegotiation Reset

The AutoNegotiation algorithm can be initiated at any time by setting the AutoNegotiation reset bit in the MI serial port Control register.

3.14.9 Link Indication

Link activity is also indicated through two pins namely $\overline{\text{LA_LED}}$ and $\overline{\text{L_LED}}$. The $\overline{\text{LA_LED}}$ is asserted whenever a link is detected and starts

blinking on activity. The $\overline{L_LED}$ is asserted whenever the device goes into the link pass state. The $\overline{LA_LED}$ is open drain with pullup resistor and can drive an LED from VDD. The $\overline{L_LED}$ output has both pullup and pull down transistors in addition to a weak pullup resistor. Since this LED is shared with the physical address input, this LED should only be driven from Vdd.

3.15 Jabber

3.15.1 100 Mbps

Jabber function is disabled in the 100 Mbps mode.

3.15.2 10 Mbps

Jabber condition occurs when the transmit packet exceeds a predetermined length. When jabber is detected, the TP transmit outputs are forced to the idle state, collision is asserted, and register bits in the MI serial port Status and Status Output registers are set.

Figure 6 SOI Output Voltage Template - 10 Mbps

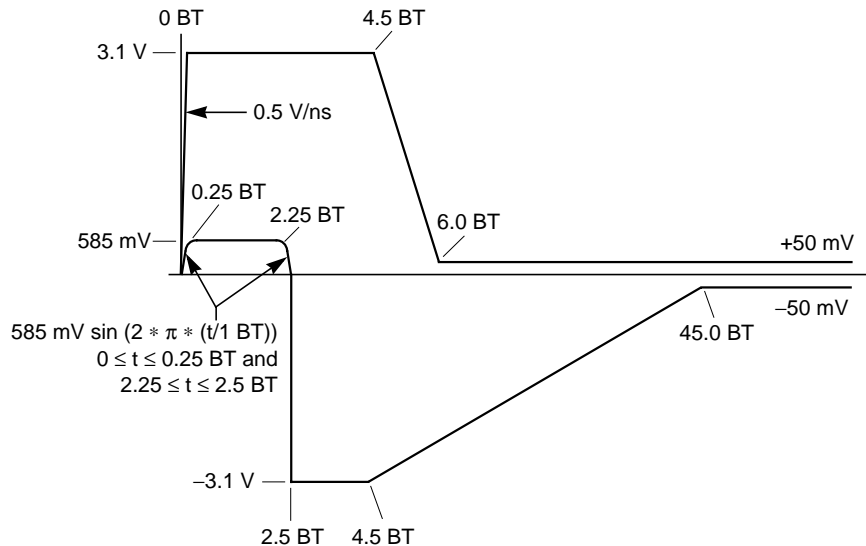

3.16 Receive Polarity Correction

3.16.1 100 Mbps

No polarity detection or correction is needed in 100 Mbps mode.

3.16.2 10 Mbps

The polarity of the signal on the TP receive input is continuously monitored. If either 3 consecutive link pulses or one SOI pulse indicates incorrect polarity on the TP receive input, the polarity is internally determined to be incorrect.

The L80225 will automatically correct for the reverse polarity.

3.17 Full Duplex Mode

3.17.1 100 Mbps

Full Duplex mode allows transmission and reception to occur simultaneously. When Full Duplex mode is enabled, collision is disabled and internal TX_EN to CRS loopback is disabled.

The device can be either forced into Half or Full Duplex mode, or the device can detect either Half or Full Duplex capability from a remote device and automatically place itself in the correct mode.

The device can be forced into the Full or Half Duplex modes by either setting the duplex bit in the MI serial port Control register or by asserting the DPLX pin assuming AutoNegotiation is not enabled.

The device can automatically configure itself for Full or Half Duplex modes by using the AutoNegotiation algorithm to advertise and detect Full and Half Duplex capabilities to and from a remote terminal. All of this is described in detail in the Link Integrity and AutoNegotiation section.

3.17.2 10 Mbps

Full Duplex in 10 Mbps mode is identical to the 100 Mbps mode.

Figure 7 Link Pulse Output Voltage Template _ NLP, FLP

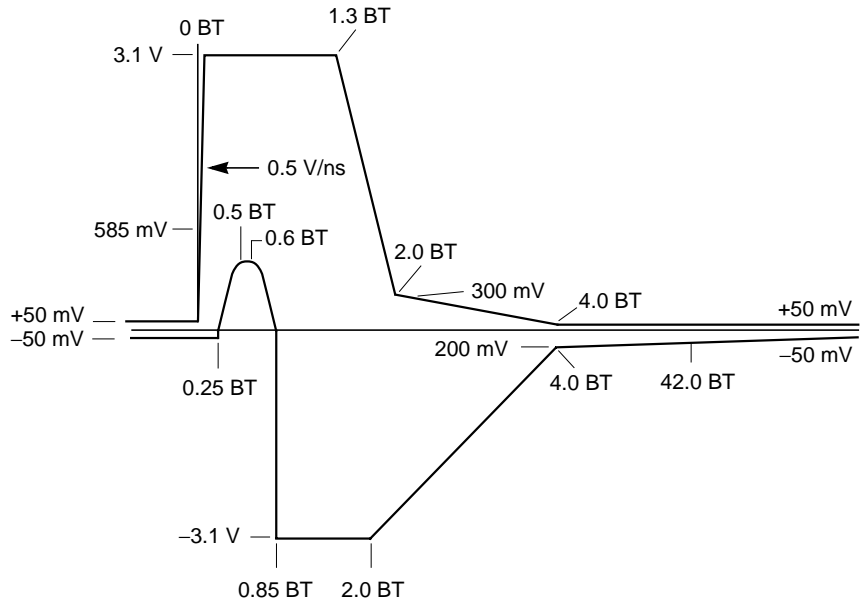

3.17.3 Full Duplex Indication

Full Duplex detection can be monitored through the $\overline{F_LED}$ pin. This pin is asserted low when the device is configured for Full Duplex operation. This output has both pullup and pull down driver transistors and a weak pullup resistor. Since this LED shared with the physical address input, it should be driven only from Vdd.

3.18 100/10 Mbps Selection

3.18.1 General

The device can be forced into either the 100 or 10 Mbps mode, or the device also can detect 100 or 10 Mbps capability from a remote device and automatically place itself in the correct mode.

The device can be forced into either the 100 or 10 Mbps mode by setting the speed select bit in the MI serial port Control register or by appropriately asserting the SPEED pin assuming AutoNegotiation is not enabled.

The device can automatically configure itself for 100 or 10 Mbps mode by using the AutoNegotiation algorithm to advertise and detect 100 and 10 Mbps capabilities to and from a remote terminal. All of this is described in detail in the Link Integrity & AutoNegotiation section. There is also a table that describes all these combinations in the ANEG pin description.

3.18.2 10/100 Mbps Indication

Please refer to the application section for information on connecting two LEDs to L_LED for indication of 10 and 100.

3.19 Loopback

3.19.1 Internal CRS Loopback

TX_EN is internally looped back onto CRS during every transmit packet. This internal CRS loopback is disabled during collision, in Full Duplex mode, and in Link Fail State. In 10 Mbps mode, internal CRS loopback is also disabled when jabber is detected.

Figure 8 NLP vs. FLP Link Pulse

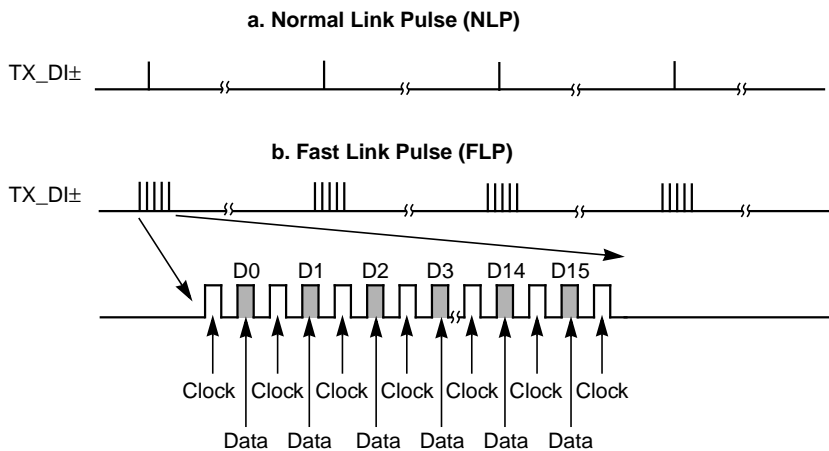

3.19.2 Diagnostic Loopback

A diagnostic loopback mode can also be selected by setting the loopback bit in the MI serial port Control register. When diagnostic loopback is

enabled, TXD[3:0] data is looped back onto RXD[3:0], TX_EN is looped back onto CRS, RX_DV operates normally, the TP receive and transmit paths are disabled, the transmit link pulses are halted, and the Half/Full Duplex modes do not change.

3.20 Reset

The device is reset when either (1) VDD is applied to the device, (2) the reset bit is set in the MI serial port Control register, or (3) the $\overline{\text{RESET}}$ pin is asserted active low. When reset is initiated by (1) or (2), an internal power-on reset pulse is generated which resets all internal circuits, forces the MI serial port bits to their default values, and latches in new values for the MI address. After the power-on reset pulse has finished, the reset bit in the MI serial port Control register is cleared and the device is ready for normal operation. When reset is initiated by (3), the same procedure occurs except the device stays in the reset state as long as the $\overline{\text{RESET}}$ pin is held low. The $\overline{\text{RESET}}$ pin has an internal pullup to VDD. The device is guaranteed to be ready for normal operation 50 ms after the reset was initiated.

3.21 Oscillator

The L80225 requires a 25 MHz reference frequency for internal signal generation. This 25 MHz reference frequency is generated by either connecting an external 25 MHz crystal between OSCIN and GND or by applying an external 25 MHz clock to OSCIN.

3.22 LED Drivers

The $\overline{\text{LA_LED}}$ and $\overline{\text{L_LED}}$ outputs are open drain with a pullup resistor and can drive LED's tied to VDD. The $\overline{\text{FD_LED}}$ and $\overline{\text{L_LED}}$ outputs have both pullup and pulldown driver transistors. Since these two LEDs also

share their outputs with the address inputs, they should be driven only from Vdd.

Table 3 LED Event Definition

Symbol	Definition
ACT	Activity Occurred, Stretch Pulse to 100 ms
COL	Collision Occurred, Stretch Pulse to 100 ms
LINK100	100 Mb Link Detected
LINK10	10 Mb Link Detected
LINK	100 or 10 Mb Link Detected
LINK+ACT	100 or 10 Mb Link Detected or Activity Occurred, Stretch Pulse To 100 ms (Link Detect Causes LED to be On, Activity Causes LED to Blink)
FDX	Full Duplex Mode Enabled
10/100	10 Mb Mode Enabled (High), or 100 Mb Mode Enabled (Low)

3.23 Repeater Mode

The L80225 has one predefined repeater mode which can be enabled by asserting the RPTR pin. When this repeater mode is enabled with the RPTR pin, the device operation is altered as follows: (1) TX_EN to CRS loopback is disabled.

3.24 MI Serial Port

3.24.1 Signal Description

The MI serial port has eight pins, MDC, MDIO, $\overline{\text{MDINT}}$, and $\overline{\text{MDA}}[3:0]$. MDC is the serial shift clock input. MDIO is a bidirectional data I/O pin. $\overline{\text{MDINT}}$ is an interrupt output. $\overline{\text{MDA}}[3:0]$ are address pins for the MI serial port.

$\overline{\text{MDA}}[3:0]$ inputs share the same pins as the LED outputs, respectively. At powerup or reset, the LED output drivers are 3-stated for an interval called the power-on reset time. During the power-on reset interval, the

value on these pins is latched into the device, inverted, and used as the MI serial port physical device addresses.

3.24.2 Timing

A timing diagram for a MI serial port frame is shown in [Figure 9](#). The MI serial port is idle when at least 32 continuous 1's are detected on MDIO and remains idle as long as continuous 1's are detected. During idle, MDIO is in the high impedance state. When the MI serial port is in the idle state, a 01 pattern on the MDIO pin initiates a serial shift cycle. Data on MDIO is then shifted in on the next 14 rising edges of MDC (MDIO is high impedance). If the register access mode is not enabled, on the next 16 rising edges of MDC, data is either shifted in or out on MDIO, depending on whether a write or read cycle was selected with the bits READ and WRITE. After the 32 MDC cycles have been completed, one complete register has been read/written, the serial shift process is halted, data is latched into the device, and MDIO goes into high impedance state. Another serial shift cycle cannot be initiated until the idle condition (at least 32 continuous 1's) is detected.

3.24.3 Bit Types

Since the serial port is bidirectional, there are many types of bits. Write bits (W) are inputs during a write cycle and are high impedance during a read cycle. Read bits (R) are outputs during a read cycle and high impedance during a write cycle. Read/Write bits (R/W) are actually write bits, which can be read out during a read cycle. R/WSC bits are R/W bits that are self-clearing after a set period of time or after a specific event has completed. R/LL bits are read bits that latch themselves when they go low, and they stay latched low until read. After they are read, they are reset high. R/LH bits are the same as R/LL bits except that they latch high. R/LT are read bits that latch themselves whenever they make a transition or change value, and they stay latched until they are read. After R/LT bits are read, they are updated to their current value. R/LT bits can

also be programmed to assert the interrupt function as described in the Interrupt section. The bit type definitions are summarized in [Table 4](#).

Table 4 MI Register Bit Type Definition

Sym.	Name	Definition	
		Write Cycle	Read Cycle
W	Write	Input	No operation, Hi Z
R	Read	No Operation, Hi Z	Output
R/W	Read/Write	Input	Output
R/WSC	Read/ Write Self Clearing	Input	Output Clears itself after operation completed
R/LL	Read/Latching Low	No Operation, Hi Z	Output When bit goes low, bit latched. When bit is read, bit updated.
R/LH	Read/Latching High	No Operation, Hi Z	Output When bit goes high, bit latched. When bit is read, bit updated.
R/LT	Read/Latching on Transition	No Operation, Hi Z	Output When bit transitions, bit latched and interrupt set. When bit is read, interrupt cleared and bit updated.

3.24.4 Frame Structure

The structure of the serial port frame is shown in [Table 5](#), and a timing diagram of a frame is shown in [Figure 9](#). Each serial port access cycle consists of 32 bits (or 192 bits if multiple register access is enabled and REGAD[4:0]=11111), exclusive of idle. The first 16 bits of the serial port cycle are always write bits and are used for addressing. The last 16/176 bits are from one/all of the 11 data registers.

The first 2 bits in [Table 5](#) and [Figure 6](#) are start bits and need to be written as a 01 for the serial port cycle to continue. The next 2 bits are

a read and write bit which determine if the accessed data register bits will be read or write. The next bit has to be a zero. The next 4 bits are device addresses and they must match the inverted values latched in from pins $\overline{\text{MDA}}[3:0]$ during the power-on reset time for the serial port access to continue. The next 5 bits are register address select bits that select one of the five data registers for access. The next 1 bit is a turnaround bit which is not an actual register bit but extra time to switch MDIO from write to read if necessary, as shown in [Figure 2](#). The final 16 bits of the MI serial port cycle (or 176 bits if multiple register access is enabled and $\text{REGAD}[4:0]=11111$) come from the specific data register designated by the register address bits $\text{REGAD}[4:0]$.

3.24.5 Register Structure

The L80225 has six internal 16 bit registers. A map of the registers is shown in [Table 5](#).

The L80225 supports only the six registers mandated by the IEEE 802.3 specification.

The structure and bit definition of the Control register is shown in [Table 6](#). This register stores various configuration inputs and its bit definition complies with the IEEE 802.3 specifications.

The structure and bit definition of the Status register is shown in [Table 7](#). This register contains device capabilities and status output information. Its bit definition complies with the IEEE 802.3 specifications.

The structure and bit definition of the PHY ID #1 and #2 registers is shown in [Table 8](#) and [Table 9](#), respectively. These registers contain an identification code unique to the L80225 and their bit definition complies with the IEEE 802.3 specifications.

The structure and bit definition of the AutoNegotiation Advertisement and AutoNegotiation Remote End Capability registers is shown in [Table 10](#) and [Table 11](#), respectively. These registers are used by the AutoNegotiation algorithm and their bit definition complies with the IEEE 802.3 specifications.

Figure 9 MI Serial Port Frame Timing Diagram

WRITE Cycle

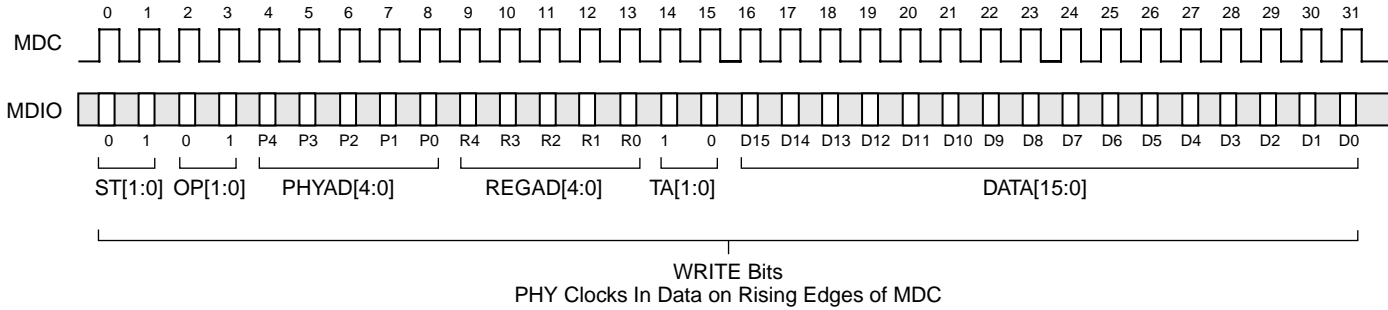

READ Cycle

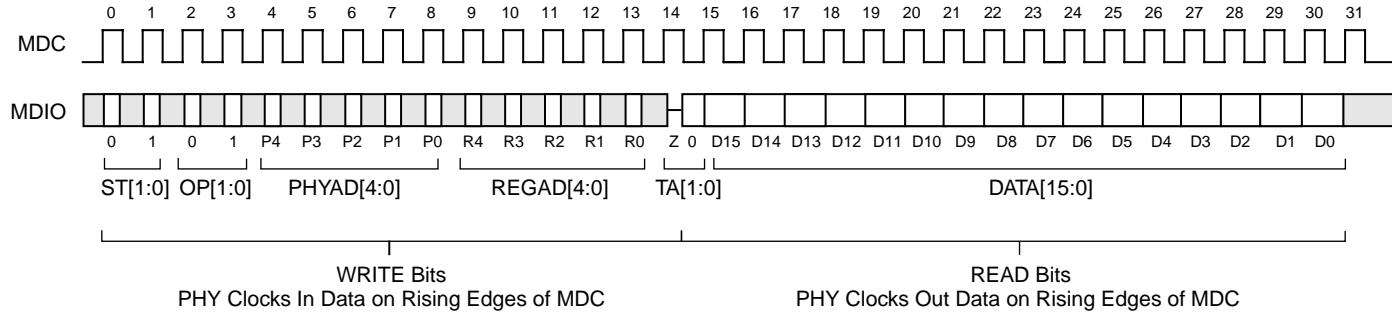
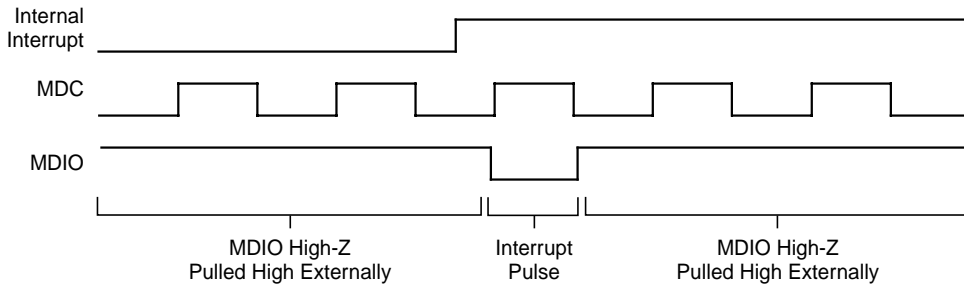
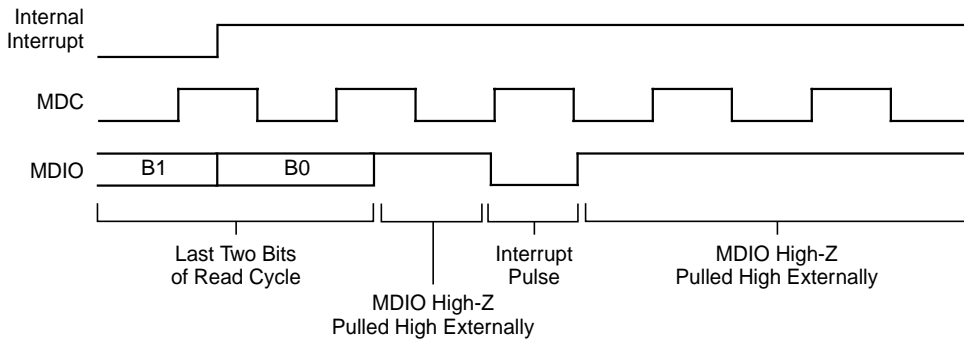

Figure 10 MDIO Interrupt Pulse

a. Interrupt Happens During Idle



b. Interrupt Happens During Read Cycle



4 Register Description

Table 5 MI Serial Port Frame Structure

<Idle>	<Start>	<Read>	<Write>	<PHY Addr.>	<Reg. Addr.>	<Turnaround>	<Data>
IDLE	ST[1:0]	READ	WRITE	PHYAD[4:0]	REGAD[4:0]	TA[1:0]	D[15:0]....

Register 0	Control
Register 1	Status
Register 2	PHY ID #1
Register 3	PHY ID #2
Register 4	AutoNegotiation Advertisement
Register 5	AutoNegotiation Remote End Capability

Symbol	Name	Definition	R/W
IDLE	Idle Pattern	These bits are an idle pattern. Device will not initiate an MI cycle until it detects at least 32 1's.	W
ST1 ST0	Start Bits	When ST[1:0]=01, an MI Serial Port access cycle starts.	W
READ	Read Select	1 = Read Cycle	W
WRITE	Write Select	1 = Write Cycle	W
PHYAD[4:0]	Physical Device Address	When PHYAD[3:0]= $\overline{\text{MDA}}[3:0]$ pins inverted and PHYAD[4] = 0, the MI Serial Port is selected for operation.	W
REGAD4[4:0]	Register Address	If REGAD[4:0]=00000-11110, these bits determine the specific register from which D[15:0] is read/written. If multiple register access is enabled and REGAD[4:0]=11111, all registers are read/written in a single cycle.	W
TA1 TA0	Turnaround Time	These bits provide some turnaround time for MDIO R/W When READ=1, TA[1:0]=Z0 When WRITE=1, TA[1:0]=ZZ	R/W
D[15:0]....	Data	These 16 bits contain data to/from one of the eleven registers selected by register address bits REGAD[4:0].	Any

IDLE is shifted in first

Table 6 MI Register 0 (Control) Structure And Bit Definition

0.15	0.14	0.13	0.12	0.11	0.10	0.9	0.8
RST	LPBK	SPEED	ANEG_EN	PDN	MII_DIS	ANEG_RST	DPLX
R/WSC	R/W	R/W	R/W	R/W	R/W	R/WSC	R/W
0.7	0.6	0.5	0.4	0.3	0.2	0.1	0.0
COLTST	0	0	0	0	0	0	0
R/W	R/W	R/W	R/W	R/W	R/W	R/W	R/W

Bit	Symbol	Name	Definition	R/W	Def.
0.15	RST	Reset	1 = Reset, bit self clearing after reset complete 0 = Normal SC	R/W SC	0
0.14	LPBK	Loopback Enable	1 = Loopback Mode Enabled 0 = Normal	R/W	0
0.13	SPEED	Speed Select	1 = 100 Mbps Selected (100BaseTX) 0 = 10 Mbps Selected (10BaseT) Note: Can be overridden with SPEED pin	R/W	1
0.12	ANEG_EN	AutoNegotiation Enable	1 = AutoNegotiation Enabled 0 = Normal Note: Can be overridden with ANEG pin	R/W	1
0.11	PDN	Powerdown Enable	1 = Powerdown 0 = Normal	R/W	0
0.10	MII_DIS	MII Interface Disable	1 = MII Interface Disabled 0 = Normal	R/W	1 ¹
0.9	ANEG_RST	AutoNegotiation Reset	1 = Restart autonegotiation process, bit self clearing after reset complete 0 = Normal	R/W SC	0
0.8	DPLX	Duplex Mode Select	1 = Full Duplex 0 = Half Duplex Note: Can be overridden with DPLX pin	R/W	0
0.7	COLTST	Collision Test Enable	1 = Collision Test Enabled 0 = Normal	R/W	0
0.6 thru 0.0			Reserved	R/W	0

1. If MDA[3:0] not = 1111, then the MII_DIS default value is changed to 0.

x.15 Bit Is Shifted First

Table 7 MI Register 1 (Status) Structure And Bit Definition

1.15	1.14	1.13	1.12	1.11	1.10	1.9	1.8
CAP_T4	CAP_TXF	CAP_TXH	CAP_TF	CAP_TH	0	0	0
R	R	R	R	R	R	R	R
1.7	1.6	1.5	1.4	1.3	1.2	1.1	1.0
0	CAP_SUPR	ANEG_ACK	REM_FLT	CAP_ANEG	LINK	JAB	EXREG
R	R	R	R/LH	R	R/LL	R/LH	R

Bit	Symbol	Name	Definition	R/W	Def.
1.15	CAP_T4	100Base-T4 Capable	0 = Not Capable of 100Base-T4 Operation	R	0
1.14	CAP_TXF	100Base-TX Full Duplex Capable	1 = Capable of 100Base-TX Full Duplex	R	1
1.13	CAP_TXH	100Base-TX Half Duplex Capable	1 = Capable of 100Base-TX Half Duplex	R	1
1.12	CAP_TF	10Base-T Full Duplex Capable	1 = Capable of 10Base-T Full Duplex	R	1
1.11	CAP_TH	10Base-T Half Duplex Capable	1 = Capable of 10Base-T Half Duplex	R	1
1.10 thru 1.7			Reserved	R	0
1.6	CAP_SUPR	MI Preamble Suppression Capable	0 = Not capable of accepting mi frames with mi preamble suppressed	R	0
1.5	ANEG_ACK	AutoNegotiation Acknowledgment	1 = AutoNegotiation acknowledgement process complete 0 = Normal	R	0
1.4	REM_FLT	Remote Fault Detect	1 = Remote Fault Detected. This bit is set when either Interrupt Detect bit 18.15 or AutoNegotiation Remote Fault bit 5.13 is set. 0 = No Remote Fault	R/LH	0
1.3	CAP_ANEG	AutoNegotiation Capable	1 = Capable of AutoNegotiation Operation	R	1

Bit	Symbol	Name	Definition	R/W	Def.
1.2	LINK	Link Status	1 = Link Detected (same as bit 18.14 inverted) 0 = Link Not Detected	R/LL	0
1.1	JAB	Jabber Detect	1 = Jabber detected (same as bit 18.8) 0 = Normal	R/LH	0
1.0	EXREG	Extended Register Capable	1 = Extended registers exist	R	1

x.15 Bit Is Shifted First

Table 8 MI Register 2 (PHY ID #1) Structure And Bit Definition

2.15	2.14	2.13	2.12	2.11	2.10	2.9	2.8
OUI3	OUI4	OUI5	OUI6	OUI7	OUI8	OUI9	OUI10
R	R	R	R	R	R	R	R
2.7	2.6	2.5	2.4	2.3	2.2	2.1	2.0
OUI11	OUI12	OUI13	OUI14	OUI15	OUI16	OUI17	OUI18
R	R	R	R	R	R	R	R

Bit	Symbol	Name	Definition	R/W	Def.
2.15	OUI3	CompanyID, Bits 3-18	OUI = 00-A0-7D	R	0
2.14	OUI4				0
2.13	OUI5				0
2.12	OUI6				0
2.11	OUI7				0
2.10	OUI8				0
2.9	OUI9				0
2.8	OUI10				0
2.7	OUI11				0
2.6	OUI12				0
2.5	OUI13				0
2.4	OUI14				1
2.3	OUI15				0
2.2	OUI16				1
2.1	OUI17				1
2.0	OUI18				0

x.15 Bit Is Shifted First

Table 9 MI Register 3 (PHY ID #2) Structure And Bit Definition

3.15	3.14	3.13	3.12	3.11	3.10	3.9	3.8
OUI19	OUI20	OUI21	OUI22	OUI23	OUI24	PART5	PART4
R	R	R	R	R	R	R	R
3.7	3.6	3.5	3.4	3.3	3.2	3.1	3.0
PART3	PART2	PART1	PART0	REV3	REV2	REV1	REV0
R	R	R	R	R	R	R	R

Bit	Symbol	Name	Definition	R/W	Def.
3.15 3.14 3.13 3.12 3.11 3.10	OUI19 OUI20 OUI21 OUI22 OUI23 OUI24	Company ID, Bits 19-24	OUI = 00-A0-7D	R	1 1 1 1 1 0
3.9 3.8 3.7 3.6 3.5 3.4	PART5 PART4 PART3 PART2 PART1 PART0	Manufacturer's Part Number	03 _H	R	0 0 0 1 1 1
3.3 3.2 3.1 3.0	REV3 REV2 REV1 REV0	Manufacturer's Revision Number		R	– – – –

x.15 Bit Is Shifted First

Table 10 MI Register 4 (AutoNegotiation Advertisement) Structure

4.15	4.14	4.13	4.12	4.11	4.10	4.9	4.8
NP	ACK	RF	0	0	0	T4	TX_FDX
R/W	R	R/W	R/W	R/W	R/W	R/W	R/W
4.7	4.6	4.5	4.4	4.3	4.2	4.1	4.0
TX_HDX	10_FDX	10_HDX	0	0	0	0	CSMA
R/W	R/W	R/W	R/W	R/W	R/W	R/W	R/W

Bit	Symbol	Name	Definition	R/W	Def.
4.15	NP	Next Page Enable	1 = Next Page Exists ¹ 0 = No Next Page	R/W	0
4.14	ACK	Acknowledge	1 = Received AutoNegotiation Word Recognized 0 = Not Recognized	R	0
4.13	RF	Remote Fault Enable	1 = AutoNegotiation Remote Fault Detected 0 = No Remote Fault	R/W	0
4.12 thru 4.10			Reserved	R/W	0
4.9	T4	100Base-T4 Capable	1 = Capable of 100Base-T4 0 = Not Capable	R/W	0
4.8	TX_FDX	100Base-TX Full Duplex Capable	1 = Capable of 100Base-TX Full Duplex 0 = Not Capable	R/W	1
4.7	TX_HDX	100Base-TX Half Duplex Capable	1 = Capable of 100Base-TX Half Duplex 0 = Not Capable	R/W	1
4.6	10_FDX	10Base-TX Full Duplex Capable	1 = Capable of 10Base-TX Full Duplex 0 = Not Capable	R/W	1
4.5	10_HDX	10Base-TX Half Duplex Capable	1 = Capable of 10Base-TX Half Duplex 0 = Not Capable	R/W	1
4.4 thru 4.1			Reserved	R/W	0
4.0	CSMA	CSMA 802.3 Capable	1 = Capable of 802.3 CSMA Operation 0 = Not Capable	R/W	1

1. Next Page is currently not supported.

x.15 Bit Is Shifted First

Table 11 MI Register 5 (AutoNegotiation Remote End Capability) Structure

5.15	5.14	5.13	5.12	5.11	5.10	5.9	5.8
NP	ACK	RF	0	0	0	T4	TX_FDX
R	R	R	R	R	R	R	R
5.7	5.6	5.5	5.4	5.3	5.2	5.1	5.0
TX_HDX	10_FDX	10_HDX	0	0	0	0	CSMA
R	R	R	R	R	R	R	R

Bit	Symbol	Name	Definition	R/W	Def.
5.15	NP	Next Page Enable	1 = Next Page Exists 0 = No Next Page	R	0
5.14	ACK	Acknowledge	1 = Received AutoNegotiation Word Recognized 0 = Not Recognized	R	0
5.13	RF	Remote Fault Enable	1 = AutoNegotiation Remote Fault Detected 0 = No Remote Fault	R	0
5.12 thru 5.10			Reserved	R	0
5.9	T4	100Base-T4 Capable	1 = Capable of 100Base-T4 0 = Not Capable	R	0
5.8	TX_FDX	100Base-TX Full Duplex Capable	1 = Capable of 100Base-TX Full Duplex 0 = Not Capable	R	1
5.7	TX_HDX	100Base-TX Half Duplex Capable	1 = Capable of 100Base-TX Half Duplex 0 = Not Capable	R	0
5.6	10_FDX	10Base-TX Full Duplex Capable	1 = Capable of 10Base-TX Full Duplex 0 = Not Capable	R	0
5.5	10_HDX	10Base-TX Half Duplex Capable	1 = Capable of 10Base-TX Half Duplex 0 = Not Capable	R	0
5.4 thru 5.1			Reserved	R	0
5.0	CSMA	CSMA 802.3 Capable	1 = Capable of 802.3 CSMA Operation 0 = Not Capable	R	0

x.15 Bit Is Shifted First

Table 12 MI Register 18 (Status Output) Structure and Bit Definition

18.15	18.14	18.13	18.12	18.11	18.10	18.9	18.8
0	1	0	0	0	0	0	0
R	R/LT	R/LT	R/LT	R/LT	R/LT	R/LT	R/LT
18.7	18.6	18.5	18.4	18.3	18.2	18.1	18.0
SPD_DET	DPLX_DET	0	0	0	0	0	0
R/LT	R/LT	R	R	R	R	R	R

Bit	Symbol	Name	Definition	R/W	Def.
18.15			Reserved for factory use	R	0
18.14			Reserved for factory use	R/LT	1
18.13			Reserved for factory use	R/LT	0
18.12			Reserved for factory use	R/LT	0
18.11			Reserved for factory use	R/LT	0
18.10			Reserved for factory use	R/LT	0
18.9			Reserved for factory use	R/LT	0
18.8			Reserved for factory use	R/LT	0
18.7	SPD_DET	100/10 Speed Detect	1 = Device in 100 Mbps Mode (100Base-TX) 0 = Device in 10 Mbps Mode (10Base-T)	R/LT	1
18.6	DPLX_DET	Duplex Detect	1 = Device in Full Duplex 0 = Device in Half Duplex	R/LT	0
18.5 18.4			Reserved for factory use	R/LT	0
18.3 thru 18.0			Reserved for factory use	R	0

x.15 Bit Is Shifted First

5 Application Information

5.1 Example Schematics

A typical example schematic of the L80225 used in an adapter card application is shown in [Figure 11](#), a hub application is shown in [Figure 12](#), and an external PHY application is shown in [Figure 13](#).

5.2 TP Transmit Interface

The interface between the TP outputs on TPO and the twisted pair cable is typically transformer coupled and terminated with the two resistors, as shown in [Figure 11](#), [Figure 12](#), and [Figure 13](#).

The transformer for the transmitter is recommended to have a winding ration of 1:1 with a center tap on the primary winding tied to VDD, as shown in [Figure 11](#), [Figure 12](#), and [Figure 13](#). The specifications for such a transformer are shown in [Table 13](#). Sources for the transformer are listed in [Table 14](#).

The transmit output needs to be terminated with two external termination resistors in order to meet the output impedance and return loss requirements of IEEE 802.3. It is recommended that these two external resistors be connected from VDD to each of the TPO outputs, and their value should be chosen to provide the correct termination impedance when looking back through the transformer from the twisted pair cable, as shown in [Figure 11](#), [Figure 12](#), and [Figure 13](#). The value of these two external termination resistors depends on the type of cable driven by the device. Refer to the Cable Selection section for more details on choosing the value of these resistors.

To minimize common mode output noise and to aid in meeting radiated emissions requirements, it may be necessary to add a common mode choke on the transmit outputs as well as add common mode bundle termination. The qualified transformers mentioned in [Table 14](#) all contain common mode chokes along with the transformers on both the transmit and receive sides, as shown in [Figure 11](#), [Figure 12](#), and [Figure 13](#). Common mode bundle termination may be needed and can be achieved by tying the unused pairs in the RJ45 to chassis ground through 75 Ohm

resistors and a 0.01 μF capacitor, as shown in [Figure 11](#), [Figure 12](#), and [Figure 13](#).

To minimize noise pickup into the transmit path in a system or on a PCB, the loading on TPO should be minimized and both outputs should always be loaded equally.

5.3 TP Receive Interface

Receive data is typically transformer coupled into the receive inputs on TPI and terminated with external resistors, as shown in [Figure 11](#), [Figure 12](#), and [Figure 13](#).

The transformer for the receiver is recommended to have a winding ratio of 1:1, as shown in [Figure 11](#), [Figure 12](#), and [Figure 13](#). The specifications for such a transformer are shown in [Table 13](#). Sources for the transformer are listed in [Table 14](#).

The receive input needs to be terminated with the correct termination impedance meet the input impedance and return loss requirements of IEEE 802.3. In addition, the receive TP inputs need to be attenuated. It is recommended that both the termination and attenuation be accomplished by placing four external resistors in series across the TPI inputs, as shown in [Figure 11](#), [Figure 12](#), and [Figure 13](#). The resistors should be 25%/25%/25%/25% of the total series resistance, and the total series resistance should be equal to the characteristic impedance of the cable (100 Ohms for UTP). It is also recommended that a 0.01 μF capacitor be placed between the center of the series resistor string and VDD in order to provide an AC ground for attenuating common mode signal at the input. This capacitor is also shown in [Figure 11](#), [Figure 12](#), and [Figure 13](#).

To minimize common mode input noise and to aid in meeting susceptibility requirements, it may be necessary to add a common mode choke on the receive input as well as add common mode bundle termination. The qualified transformers mentioned in [Table 14](#) all contain common mode chokes along with the transformers on both the transmit and receive sides, as shown in [Figure 11](#), [Figure 12](#), and [Figure 13](#). Common mode bundle termination may be needed and can be achieved by tying the receive secondary center tap and the unused pairs in the RJ45 to chassis ground through 75 Ohm resistors and a 0.01 μF capacitor, as shown in [Figure 11](#), [Figure 12](#), and [Figure 13](#).

In order to minimize noise pickup into the receive path in a system or on a PCB, loading on TPI should be minimized and both inputs should be loaded equally.

Figure 11 Typical Network Interface Card Schematic Using L80225

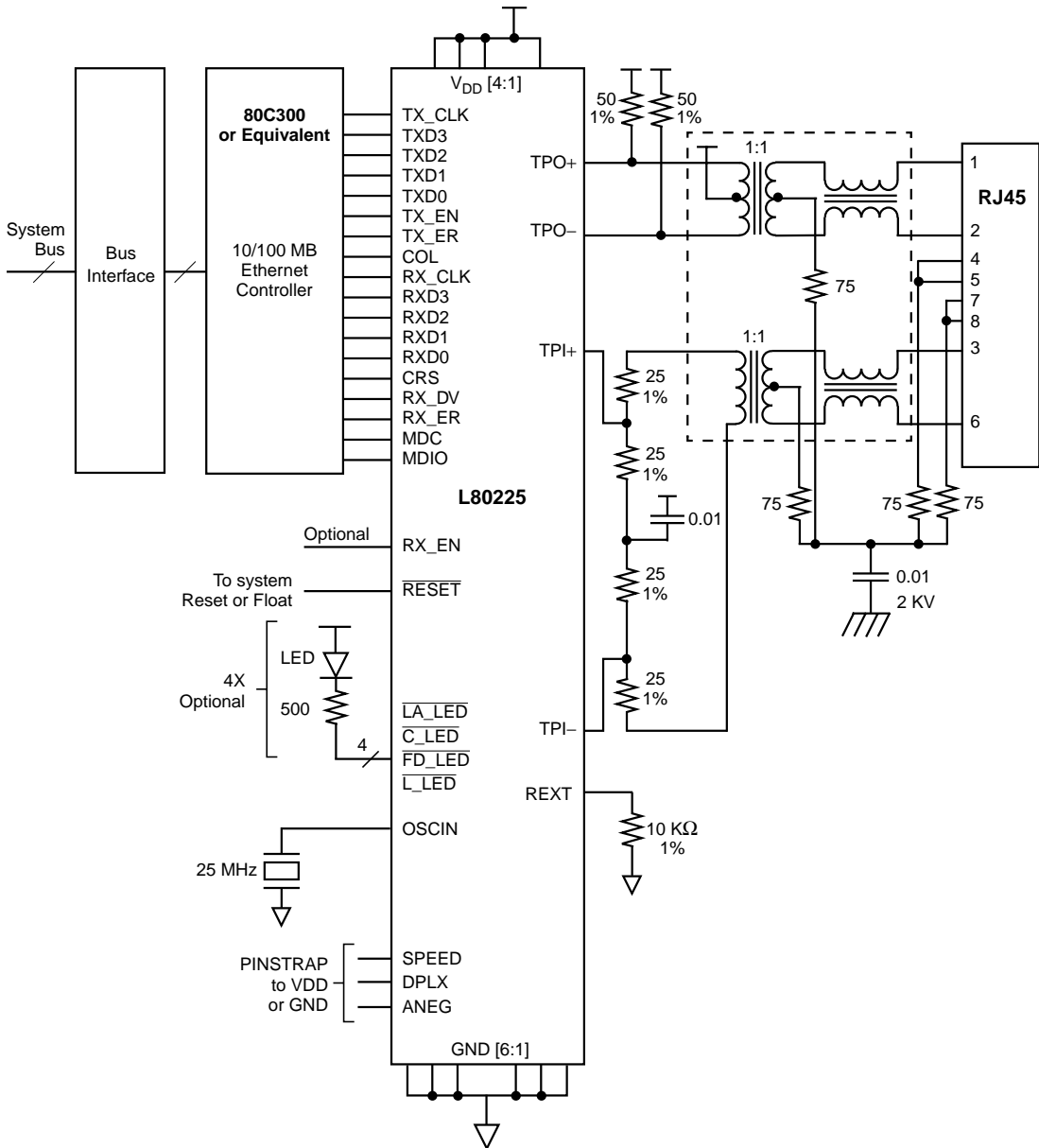

Figure 12 Typical Switching Port Schematic Using L80225

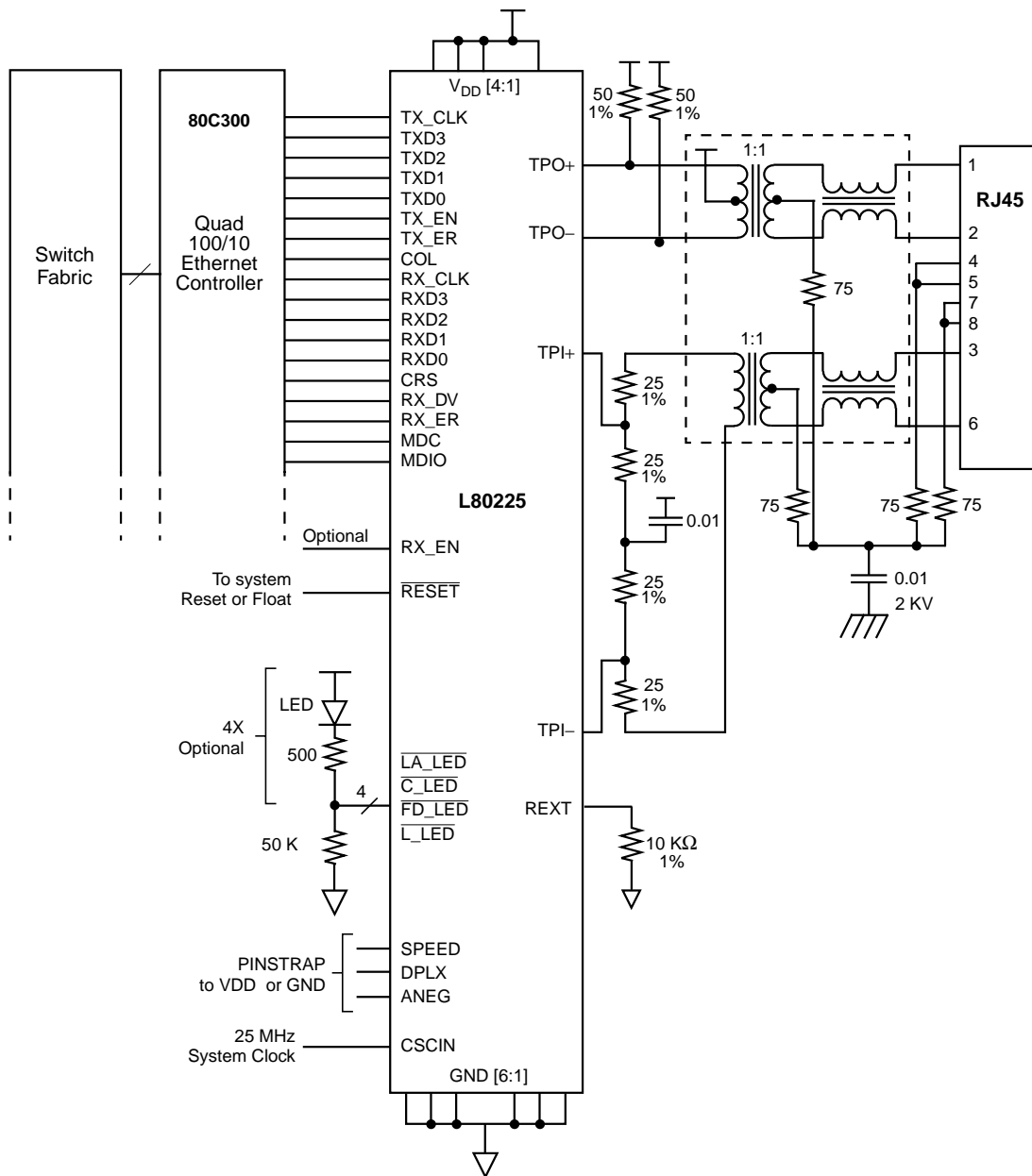

Figure 13 Typical External PHY Schematic Using L80225

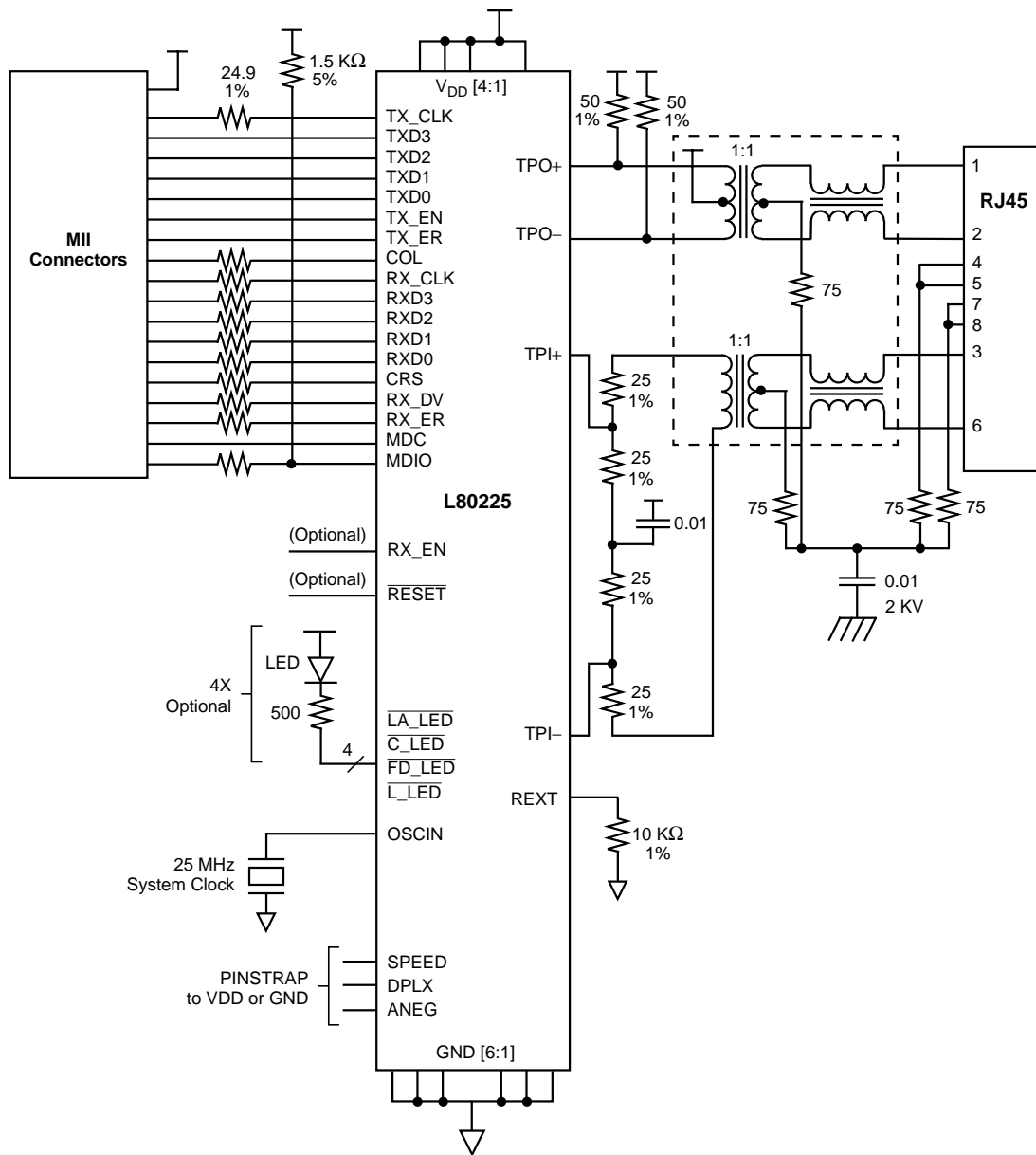

Table 13 Transformer Specification

Parameter	Specification	
	Transmit	Receive
Turns Ratio	1:1 CT	1:1
Inductance, (μ H Min)	350	350
Leakage Inductance, (μ H)	0.05-0.15	0.0-0.2
Capacitance (pF Max)	15	15
DC Resistance (Ohms Max)	0.4	0.4

Table 14 TP Transformer Sources

Vendor	Part Number
PULSE	H1089, H1102
BEL	S558-5999-J9, 558-5999-46
HALO	TG22-3506ND, TG110-S050N2
PCA	EPF8017GH

Note: H1089, S558-5999-46, EPF8017GH, and TG22-3506ND are pin compatible. Please contact the transformer vendor for additional information.

5.4 TP Transmit Output Current Set

The TPO output current level is set by an external resistor tied between REXT and GND. This output current is determined by the following equation where R is the value of REXT:

$$I_{out} = (10K/R) I_{ref}$$

Where I_{ref} = 40 mA (100 Mbps, UTP)
= 32.6 mA (100 Mbps, STP)
= 100 mA (10 Mbps, UTP)
= 81.6 mA (10 Mbps, STP)

REXT should be typically set to 10K Ohms and REXT should be a 1% resistor in order to meet IEEE 802.3 specified levels. Once REXT is set for the 100 Mbps and UTP modes as shown by the equation above, Iref is then automatically changed inside the device when the 10 Mbps mode or UTP120/STP150 modes are selected.

Keep REXT close to the REXT and GND pins as possible in order to reduce noise pickup into the transmitter.

Since the TP output is a current source, capacitive and inductive loading can reduce the output voltage level from the ideal. Thus, in actual application, it might be necessary to adjust the value of the output current to compensate for external loading. One way to adjust the TP output level is to change the value of the external resistor tied to REXT.

5.5 Transmitter Droop

The IEEE 802.3 specification has a transmit output droop requirement for 100BaseTX. Since the L80225 TP output is a current source, it has no perceptible droop by itself. However, the inductance of the transformer added to the device transmitter output, as shown in [Figure 11](#), [Figure 12](#), and [Figure 13](#), will cause droop to appear at the transmit interface to the TP wire. If the transformer connected to the L80225 outputs meets the requirements in [Table 13](#), the transmit interface to the TP cable will meet the IEEE 802.3 droop requirements.

5.6 MII Controller Interface

5.6.1 General

The MII controller interface allows the L80225 to connect to any external Ethernet controller without any glue logic provided that the external Ethernet controller has a MII interface that complies with IEEE 802.3, as shown in [Figure 11](#), [Figure 12](#), and [Figure 13](#).

5.6.2 Clocks

Standard Ethernet controllers with a MII use TX_CLK to clock data in on TXD[3:0]. TX_CLK is specified in IEEE 802.3 and on the L80225 to be an output. If a nonstandard controller or other digital device is used to interface to the L80225, there might be a need to clock TXD[3:0] into the L80225 on the edges of an external master clock. The master clock, in

this case, would be an input to the L80225. This can be done by using OSCIN as the master clock input; since OSCIN generates TX_CLK inside the L80225, data on TXD[3:0] can be clocked into the L80225 on edges of output clock TX_CLK or input clock OSCIN. In the case where OSCIN is used as the input clock, a crystal is no longer needed on OSCIN, and TX_CLK can be left open or used for some other purpose.

5.6.3 Output Drive

The digital outputs on the L80225 controller signals meet the MII driver characteristics specified in IEEE 802.3 and shown in Figure 16 if external 24.9 ohm 1% termination resistors are added. These termination resistors are only needed if the outputs have to drive a MII cable or other transmission line type load, such as in the external PHY application shown in Figure 13. If the L80225 is used in embedded applications, such as adapter cards and switching hubs shown in Figure 11 and Figure 12, then these terminations resistors are not needed.

5.6.4 MII Disable

The MII outputs can be placed in the high impedance state and inputs disabled by setting the MII disable bit in the MI serial port Control register. When this bit is set to the disable state, the TP outputs are also disabled and transmission is inhibited. The default value of this bit when the device powers up or is reset is dependent on the physical device address. If the device address latched into $\overline{\text{MDA}}[3:0]$ at reset is 1111, it is assumed that the device is being used in applications where there maybe more than one device sharing the MII bus, like external PHY's or adapter cards, so the device powers up with the MII interface disabled. If the device address latched into $\overline{\text{MDA}}[3:0]$ at reset is not 1111, it is assumed that the device is being used in application where it is the only device on the MII bus, like hubs, so the device powers up with the MII interface enabled.

Figure 14 MII Output Driver Characteristics

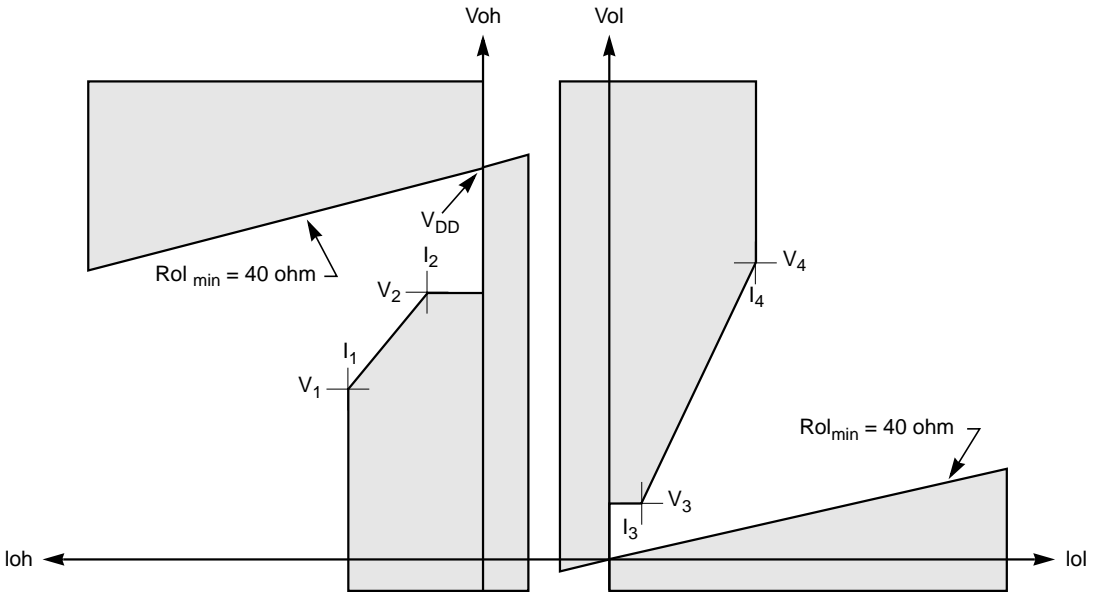

I - V	I (mA)	V (Volts)
I ₁ , V ₁	-20	1.10
I ₂ , V ₂	-4	2.40
I ₃ , V ₃	4	0.40
I ₄ , V ₄	43	3.05

5.6.5 Receive Output Enable

The receive output enable pin, RX_EN, forces the receive and collision MII/FBI outputs into the high impedance state. More specifically, when RX_EN is deasserted, RX_CLK, RXD[3:0], RX_DV, RX_ER, and COL are placed in high impedance.

RX_EN can be used to "wire OR" the outputs of many L80225 devices in multiport applications where only one device may be receiving at a time, like a repeater. By monitoring CRS from each individual port, the repeater can assert only the one RX_EN to that L80225 device which is receiving data. The method will reduce, by 8 per device, the number of pins and PCB traces required by a repeater core IC.

The RX_EN function can be enabled by appropriately setting the R/J Configuration select bit in the MI serial port Configuration 2 register. When this bit is set, the RX_EN pin becomes RX_EN.

5.7 Repeater Applications

5.7.1 MII Based Repeaters

The L80225 can be used as the physical interface for MII based repeaters by using the standard MII as the interface to the repeater core.

For most repeaters, it is necessary to disable the internal CRS loopback.

For some particular types of repeaters, it may be desirable to either enable or disable AutoNegotiation, force Half Duplex operation, and enable either 100 Mbps or 10 Mbps operation. All of these modes can be configured by setting the appropriate bits in the MI serial port Control register or by enabling/disabling the Speed, Duplex and ANEG pins.

The L80225 has a RPTR pin which will automatically configure the device for one common type of repeater application. When the RPTR pin is asserted, the TX_EN to CRS loopback is automatically disabled.

The MII requires 16 signals between the L80225 and a repeater core. The MII signal count to a repeater core will be 16 multiplied by the number of ports, which can be quite large. The signal count between the L80225 and repeater core can be reduced by 8 per device by sharing the receive output pins and using RX_EN to enable only that port where CRS is asserted. Refer to the Controller Interface section within the Applications section for more details about RX_EN.

5.7.2 Clocks

Normally, transmit data over the MII/FBI is clocked into the L80225 with edges from the output clock TX_CLK. It may be desirable or necessary in some repeater applications to clock in the transmit data from a master clock from the repeater core. This would require that transmit data be clocked in on edges of an input clock. An input clock is available for clocking in data on TXD with the OSCIN pin. Notice from the timing diagrams that OSCIN generates TX_CLK, and TXD data is clocked in on TX_CLK edges. This means that TXD data is also clocked in on OSCIN

edges as well. Thus, an external clock driving the OSCIN input can also be used as the clock for TXD.

5.8 Serial Port

5.8.1 General

The L80225 has a MI serial port to access the device's configuration inputs and read out the status outputs. Any external device that has a IEEE 802.3 compliant MI interface can connect directly to the L80225 without any glue logic, as shown in [Figure 11](#), [Figure 12](#), and [Figure 13](#).

As described earlier, the MI serial port consists of 8 lines: MDC, MDIO, $\overline{\text{MDINT}}$, and $\overline{\text{MDA}}[3:0]$. However, only 2 lines, MDC and MDIO, are needed to shift data in and out; $\overline{\text{MDINT}}$ and $\overline{\text{MDA}}[3:0]$ are not needed but are provided for convenience only.

Note that the $\overline{\text{MDA}}[3:0]$ addresses are inverted inside the L80225 before going to the MI serial port block. This means that the $\overline{\text{MDA}}[3:0]$ pins would have to be pin strapped to 1111 externally in order to successfully match the MI physical address of 00000 on the PHYAD[4:0] bits internally. The MSB of the address is internally tied to zero.

5.8.2 Serial Port Addressing

The device address for the MI serial port are selected by tying the $\overline{\text{MDA}}[3:0]$ pins to the desired value. $\overline{\text{MDA}}[3:0]$ share the same pins as the LED outputs, respectively, as shown in part a. of [Figure 15](#). At powerup or reset, the output drivers are 3-stated for an interval called the power-on reset time. During the power-on reset interval, the value on these pins is latched into the device, inverted, and used as the MI serial port address. The LED outputs are open drain with internal resistor pullup to VDD.

If an LED is desired on the LED outputs, then an LED and resistor are tied to VDD as shown in part b. of [Figure 15](#). If a high address is desired, then the LED to VDD automatically makes the latched address value a high. If a low value for the address is desired, then a 50K resistor to GND must be added as shown in part b. of [Figure 15](#).

If no LED's are needed on the LED outputs, the selection of addresses can be done as shown in part c. of [Figure 15](#). If a high address is

desired, the pin should be left floating and the internal pullup will pull the pin high during power-on reset time and latch in a high address value. If a low address is desired, then the LED output pins should be tied either directly to GND or through an optional 50K resistor to GND. $\overline{\text{FD_LED}}$ and $\overline{\text{L_LED}}$ should always be tied through a 50K resistor to GND since they have both pullup and pulldown capability. The optional 50K resistor also allows the Link, Full Duplex, and Collision LED pins to be used as digital outputs under normal conditions.

Note that the $\overline{\text{MDA}}[3:0]$ addresses are inverted inside the L80225 before going to the MI serial port block. This means that the $\overline{\text{MDA}}[3:0]$ pins would have to be pin strapped to 1111 externally in order to successfully match the MI physical address bits $\text{PHYAD}[4:0]=00000$ internally.

Figure 15 Serial Device Port Address Selection

a. Output Driver/Input Address Correspondence

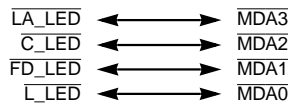

b. Setting Address with LEDs

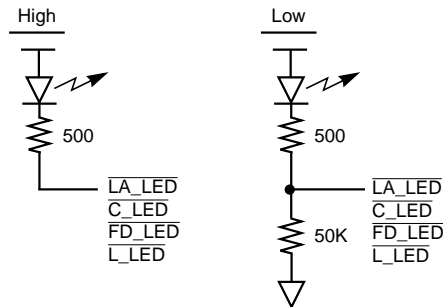

c. Setting Address without LEDs

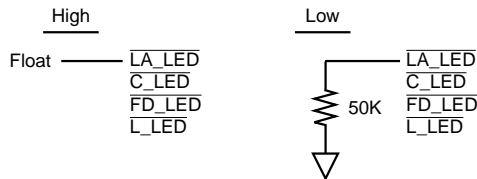

5.9 Oscillator

The L80225 requires a 25 MHz reference frequency for internal signal generation. This 25 MHz reference frequency can be generated by either connecting an external 25 MHz crystal between OSCIN and GND or by applying an external 25 MHz clock to OSCIN.

If the crystal oscillator is used, it needs only a crystal, and no other external capacitors or other components are required. The crystal must have the characteristics shown in [Table 15](#). The crystal must be placed as close as possible to OSCIN and GND pins so that parasitics on OSCIN are kept to a minimum.

Table 15 Crystal Specifications

Parameter	Spec
Type	Parallel Resonant
Frequency	25 MHz 0.01%
Equivalent Series Resistance	25 ohms max
Load Capacitance	18 pF typ
Case Capacitance	7 pF max
Power Dissipation	1 mW max

5.10 LED Drivers

The LED outputs can all drive LED's tied to VDD, as shown in [Figure 11](#), [Figure 12](#), and [Figure 13](#).

The LED outputs can also drive other digital inputs. Thus, LED can also be used as digital outputs whose function can be user defined and controlled through the MI serial port.

5.11 Power Supply Decoupling

There are four VDDs on the L80225 (VDD[4:1]) and six GNDs (GND[6:1]).

All six VDDs should be connected together as close as possible to the device with a large VDD plane. If the VDDs vary in potential by even a

small amount, noise and latchup can result. The VDD's should be kept to within 50 mV of each other.

All six GNDs should also be connected together as close as possible to the device with a large ground plane. If the GNDs vary in potential by even a small amount, noise and latchup can result. The VDD's should be kept to within 50 mV of each other.

A 0.01-0.1 μ F decoupling capacitor should be connected between each VDD/GND set as close as possible to the device pins, preferably within 0.5". The value should be chosen on the basis of whether the noise from VDD-GND is high or low frequency. A conservative approach would be to use two decoupling capacitors on each VDD/GND set, one 0.1 μ f for low frequency and one 0.001 μ f for high frequency noise on the power supply.

The VDD connection to the transmit transformer center tap shown in [Figure 11](#), [Figure 12](#), and [Figure 13](#) has to be well decoupled in order to minimize common mode noise injection from the supply into the twisted pair cable. It is recommended that a 0.01 μ F decoupling capacitor be placed between the center tap VDD to the S004 GND plane. This decoupling capacitor should be physically placed as close as possible to the transformer center tap, preferably within 0.5"

The PCB layout and power supply decoupling discussed above should provide sufficient decoupling to achieve the following when measured at the device: (1) The resultant AC noise voltage measured across each VDD/GND set should be less than 100 mVpp, (2) All VDD's should be within 50 mVpp of each other, and (3) All GNDs should be within 50 mVpp of each other.

6 Specifications

6.1 Absolute Maximum Ratings

Absolute maximum ratings are limits beyond which may cause permanent damage to the device or affect device reliability. All voltages are specified with respect to GND, unless otherwise specified.

- VDD Supply Voltage -0.3 V to +4.0 V
- All Inputs and Outputs -0.3 V to 5.5 V
- Package Power Dissipation 2.0 Watt @ 70 °C
- Storage Temperature -65 to +150 °C
- Temperature Under Bias -10 to +80 °C
- Lead Temperature (Soldering, 10 Sec) 260 °C
- Body Temperature (Soldering, 30 Sec) 220 °C

6.2 DC Electrical Characteristics

Unless otherwise noted, all test conditions are as follows:

1. $T_A = 0$ to +70 °C
2. $V_{DD} = 3.3$ V 5%
3. 25 MHz 0.01%
4. REXT = 10K 1%, no load

Sym.	Parameter	Limit			Unit	Conditions
		Min	Typ	Max		
VIL	Input Low Voltage			0.8	Volt	All except OSCIN, $\overline{MDA}[3:0]$,
				VDD-1.0	Volt	$\overline{MDA}[3:0]$
				1.5	Volt	OSCIN
VIH	Input High Voltage	2		5.5	Volt	All except OSCIN, $\overline{MDA}[3:0]$,
		VDD -0.5			Volt	$\overline{MDA}[3:0]$
		2.5			Volt	OSCIN

Sym.	Parameter	Limit			Unit	Conditions
		Min	Typ	Max		
IIL	Input Low Current			-1	uA	VIN=GND. All except OSCIN, MDA[3:0], RESET
		-4		-25	uA	VIN=GND. $\overline{\text{MDA}}[3:0]$
		-12		-120	uA	VIN=GND. RESET
				-150	uA	VIN=GND. OSCIN
IIH	Input High Current			1	uA	VIN=VDD. All except OSCIN, RPTR
		12		120	uA	VIN=VDD. RPTR
				150	uA	VIN=VDD. OSCIN
VOL	Output Low Voltage			0.4	Volt	IOL=-4 mA. All except LED
				1	Volt	IOL=-10 mA. LED
VOH	Output High Voltage	VDD-1.0			Volt	IOH=4 mA. All except LED
		2.4			Volt	IOH=4 uA. $\overline{\text{L_LED}}$
		VDD-1.0			Volt	IOH=10mA. $\overline{\text{FD_LED}}$
CIN	Input Capacitance		5		pF	
IDD	VDD Supply Current			120	mA	Transmitting, 100 Mbps
				140	mA	Transmitting, 10 Mbps
IGND	GND Supply Current			190	mA	Transmitting, 100 Mbps ¹
				220	mA	Transmitting, 10 Mbps ¹
IPDN	Powerdown Supply Current			200	uA	Powerdown, either IDD or IGND

1. IGND includes current flowing into GND from the external resistors and transformer on TPO as shown in [Figure 11](#).

6.3 Twisted Pair Characteristics, Transmit

Unless otherwise noted, all test conditions are as follows:

1. $T_A = 0$ to $+70$ °C
2. $V_{DD} = 3.3$ V 5%
3. 25 MHz 0.01%
4. $R_{EXT} = 10K$ 1%, no load
5. TPO loading shown in [Figure 11](#), or equivalent.

Sym.	Parameter	Limit			Unit	Conditions
		Min	Typ	Max		
T _{OV}	TP Differential Output Voltage	0.950	1.000	1.050	V pk	100 Mbps, UTP Mode, 100 Ohm load
		2.2	2.5	2.8	V pk	10 Mbps, UTP Mode, 100 Ohm load
T _{OVS}	TP Differential Output Voltage Symmetry	98		102	%	100 Mbps, ratio of positive and negative amplitude peaks on TPO
T _{ORF}	TP Differential Output Rise And Fall Time	3.0		5.0	ns	100 Mbps
T _{ORFS}	TP Differential Output Rise And Fall Time Symmetry			0.5	ns	100 Mbps, Difference between rise and fall times on TPO
T _{ODC}	TP Differential Output Duty Cycle Distortion			0.25	ns	100 Mbps, Output Data = 0101... NRZ Pattern unscrambled, measure at 50% points
T _{OJ}	TP Differential Output Jitter			1.4	ns	100 Mbps, Output Data=scrambled /H/
T _{OO}	TP Differential Output Overshoot			5.0	%	100 Mbps
T _{OVT}	TP Differential Output Voltage Template	See Figure 4				10 Mbps
T _{SOI}	TP Differential Output SOI Voltage Template	See Figure 6				10 Mbps
T _{LPT}	TP Differential Output Link Pulse Voltage Template	See Figure 7				10 Mbps, NLP and FLP
T _{OIV}	TP Differential Output Idle Voltage			50	mV	10 Mbps. Measured on secondary side of Xfmr in Figure 11 .

Sym.	Parameter	Limit			Unit	Conditions
		Min	Typ	Max		
T _{OIA}	TP Output Current	38	40	42	mA pk	100 Mbps
		88	100	112	mA pk	10 Mbps
T _{OIR}	TP Output Current Adjustment Range	0.80		1.2		V _{DD} = 3.3V, Adjustable with REXT, relative to T _{OIA} with REXT=10K
T _{OR}	TP Output Resistance		10K		Ohm	
T _{OC}	TP Output Capacitance		15		pF	

6.4 Twisted Pair Characteristics, Receive

Unless otherwise noted, all test conditions are as follows:

1. T_A = 0 to +70 °C
2. V_{CC} = 3.3 V 5%
3. 25 MHz 0.01%
4. REXT = 10K 1%, no load
5. 62.5/10 MHz Square Wave on TP inputs in 100/10 Mbps

Sym.	Parameter	Limit			Unit	Conditions
		Min	Typ	Max		
R _{ST}	TP Input Squelch Threshold	166		500	mV pk	100 Mbps, RLVL=0
		310		540	mV pk	10 Mbps, RLVL=0
R _{UT}	TP Input Unsquelch Threshold	100		300	mV pk	100 Mbps, RLVL=0
		186		324	mV pk	10 Mbps, RLVL=0
R _{OCV}	TP Input Open Circuit Voltage		V _{DD} -2.4 ± 0.2		Volt	Voltage on either TPI+ or TPI- with respect to GND.
R _{CMR}	TP Input Common Mode Voltage Range		R _{OCV} 0.25		Volt	Voltage on TPI with respect to GND.
R _{DR}	TP Input Differential Voltage Range			V _{DD}	Volt	
R _{IR}	TP Input Resistance	5K			Ohm	
R _{IC}	TP Input Capacitance		10		pF	

6.5 AC Test Timing Conditions

Unless otherwise noted, all test conditions are as follows:

1. $T_A = 0$ to $+70$ °C
2. $V_{DD} = 3.3$ V 5%
3. 25 MHz 0.01%
4. REXT = 10K 1%, no load
5. Input conditions:
All Inputs: $t_r, t_f \leq 10$ nS, 20-80%
6. Output Loading
TPO : Same as [Figure 11](#) or equivalent, 10 pF
Open Drain Outputs: 1K Pullup, 50 pF
All Other Digital Outputs: 25 pF
7. Measurement Points:
TPO ,TPI : 0.0 V during data, 0.3V at start/end of packet
All other inputs and outputs: 1.4 V

6.6 25 MHz Input / Output Clock Timing Characteristics

Refer to [Figure 16](#) for Timing Diagram.

Sym.	Parameter	Limit			Unit	Conditions
		Min	Typ	Max		
t_1	OSCIN Period	39.996	40	40.004	ns	Clock applied to OSCIN
t_2	OSCIN High Time	16			ns	Clock applied to OSCIN
t_3	OSCIN Low Time	16			ns	Clock applied to OSCIN
t_4	OSCIN to TX_CLK Delay			10	ns	100 Mbps
				20	ns	10 Mbps

Figure 16 25 MHz Output Timing

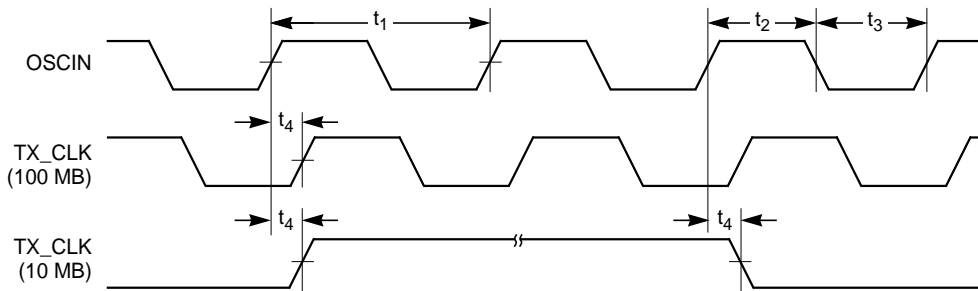

6.7 Transmit Timing Characteristics

Refer to [Figure 17](#) and [Figure 18](#) for Timing Diagram.

Sym.	Parameter	Limit			Unit	Conditions
		Min	Typ	Max		
t ₁₁	TX_CLK Period	39.996	40	40.004	ns	100 Mbps
		399.96	400	400.04	ns	10 Mbps
t ₁₂	TX_CLK Low Time	16	20	24	ns	100 Mbps
		160	200	240	ns	10 Mbps
t ₁₃	TX_CLK High Time	16	20	24	ns	100 Mbps
		160	200	240	ns	10 Mbps
t ₁₄	TX_CLK Rise/Fall Time			10	ns	
t ₁₅	TX_EN Setup Time	15			ns	Note 1
t ₁₆	TX_EN Hold Time	0			ns	
t ₁₇	CRS During Transmit Assert Time			40	ns	100 Mbps
				400	ns	10 Mbps
t ₁₈	CRS During Transmit Dessert Time			160	ns	100 Mbps
				900	ns	10 Mbps
t ₁₉	TXD Setup Time	15			ns	Note 1
t ₂₀	TXD Hold Time	0			ns	
t ₂₁	TX_ER Setup Time	15			ns	Note 1
t ₂₂	TX_ER Hold Time	0			ns	
t ₂₃	Transmit Propagation Delay	60		140	ns	100 Mbps, MII
				600	ns	10 Mbps

Sym.	Parameter	Limit			Unit	Conditions
		Min	Typ	Max		
t ₂₄	Transmit Output Jitter			±0.7	ns pk-pk	100 Mbps
				±5.5	ns pk-pk	10 Mbps
t ₂₅	Transmit SOI Pulse Width To 0.3V	250			ns	10 Mbps
t ₂₆	Transmit SOI Pulse Width to 40 mV			4500	ns	10 Mbps
t ₂₇	LA_LED Delay Time			25	ms	LA_LED activity
t ₂₈	LA_LED Pulse Width	80		105	ms	LA_LED activity

Note 1: Setup time measured with 5 pF loading on TXC. Additional leading will create delay on TXC rise time, which will require increased setup times accordingly.

Figure 17 Transmit Timing - 100 Mbps

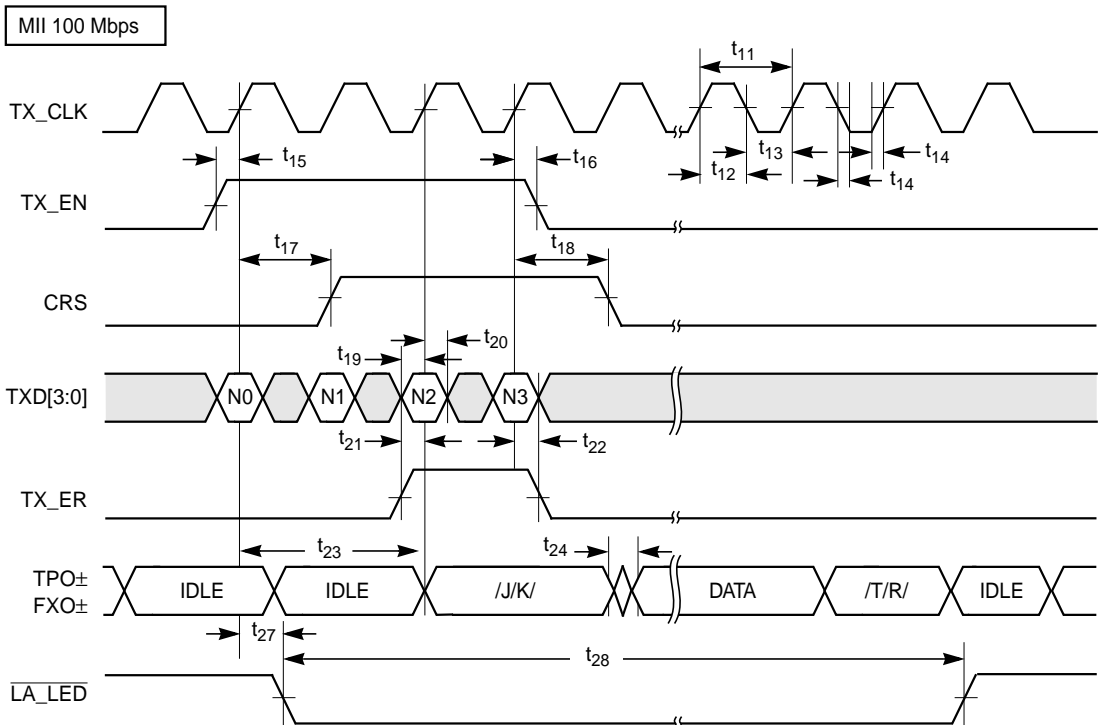
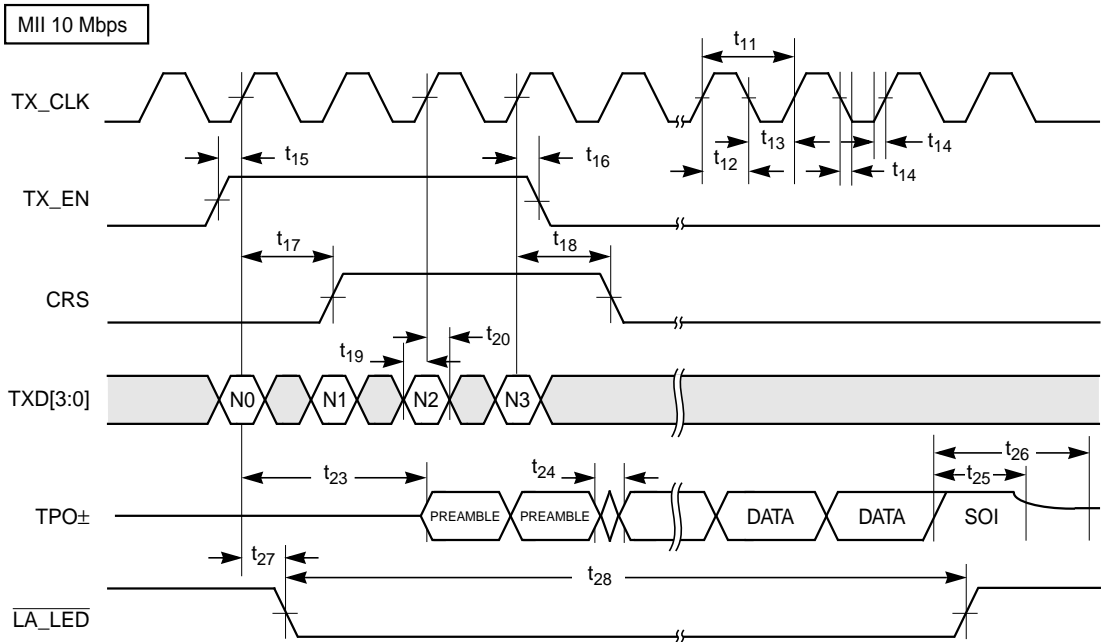

Figure 18 Transmit Timing - 10 Mbps



6.8 Receive Timing Characteristics

Refer to [Figure 19](#) through [Figure 23](#) for Timing Diagrams.

Sym.	Parameter	Limit			Unit	Conditions
		Min	Typ	Max		
t_{31}	Start Of Packet To CRS Assert Delay			200	ns	100 Mbps, MII
				700	ns	10 Mbps
t_{32}	End Of Packet To CRS Deassert Delay	130		240	ns	100 Mbps, MII
				600	ns	10 Mbps. relative to start of SOI pulse
t_{33}	Start Of Packet To RX_DV Assert Delay			240	ns	100 Mbps
				3600	ns	10 Mbps
t_{34}	End Of Packet To RX_DV Deassert Delay			280	ns	100 Mbps
				1000	ns	10 Mbps. relative to start of SOI pulse

Sym.	Parameter	Limit			Unit	Conditions
		Min	Typ	Max		
t ₃₇	RX_CLK To RX_DV, RXD, RX_ER Delay	-8		8	ns	100 Mbps
		-80		80	ns	10 Mbps
t ₃₈	RX_CLK High Time	18	20	22	ns	100 Mbps
		180	200	600	ns	10 Mbps
t ₃₉	RX_CLK Low Time	18	20	22	ns	100 Mbps
		180	200	600	ns	10 Mbps
t ₄₀	SOI Pulse Minimum Width Required for Idle Detection	125		200	ns	10 Mbps Measure TPI from last zero cross to 0.3V point.
t ₄₁	Receive Input Jitter			±3.0	ns pk – pk	100 Mbps
				±13.5	ns pk –pk	10 Mbps
t ₄₃	LA_LED Delay Time			25	ms	LA_LED
t ₄₄	LA_LED Pulse Width	80		105	ms	LA_LED
t ₄₅	RX_CLK, RXD, CRC, RX_DV, RX_ER Output Rise and Fall Times			10	ns	
t ₄₆	RX_EN Deassert to Rcv MII Output HI-Z Delay			40	ns	
t ₄₇	RX_EN Assert to Rcv MII Output Active Delay			40	ns	

Figure 19 Receive Timing, Start of Packet - 100 Mbps

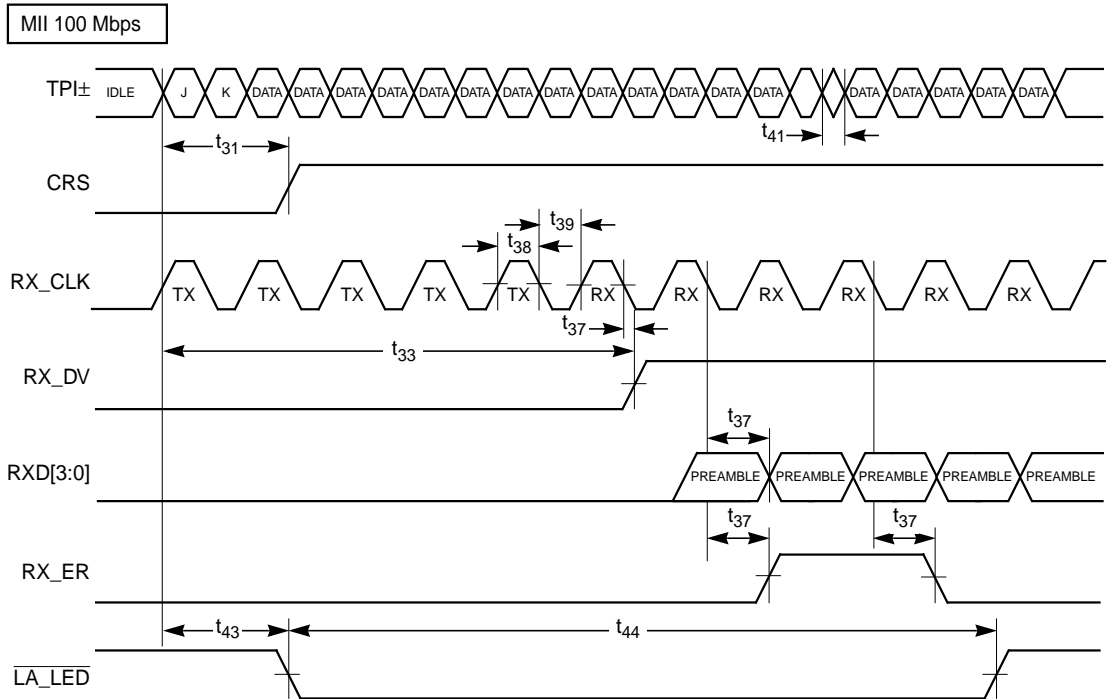

Figure 20 Receive Timing, End of Packet - 100 Mbps

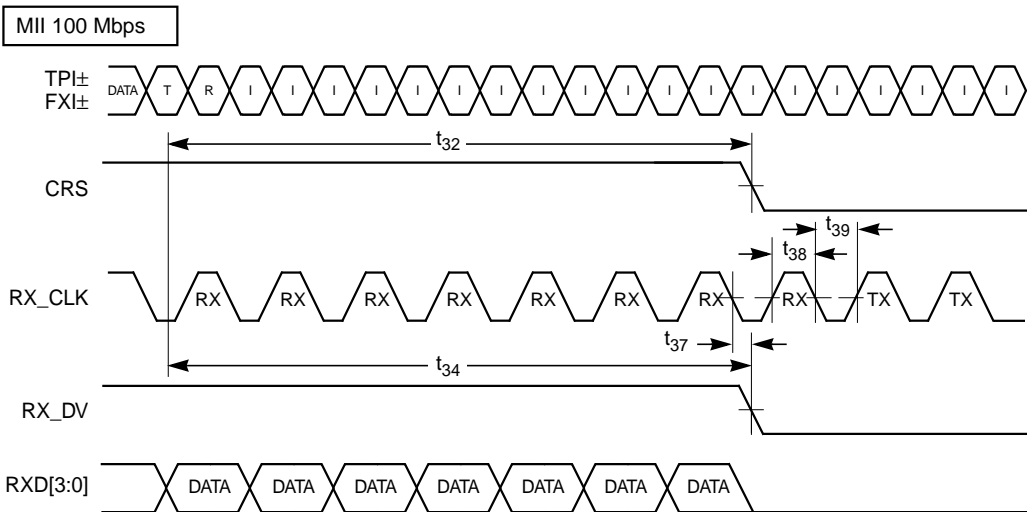

Figure 21 Receive Timing, Start of Packet - 10 Mbps

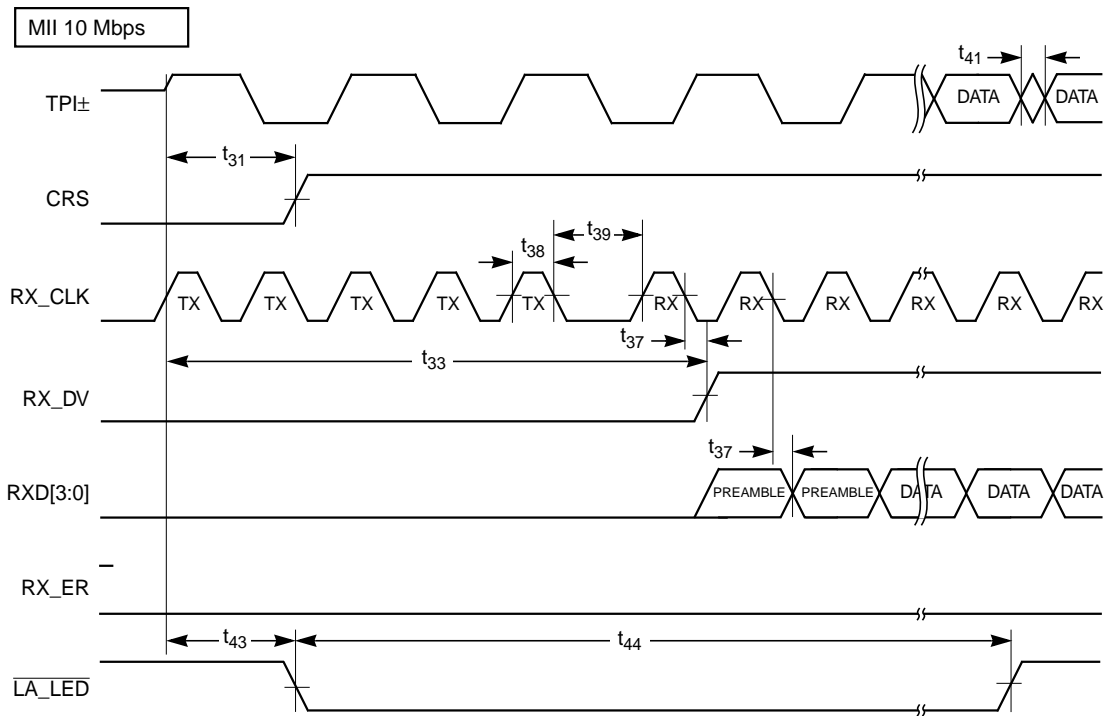

Figure 22 Receive Timing, End of Packet - 10 Mbps

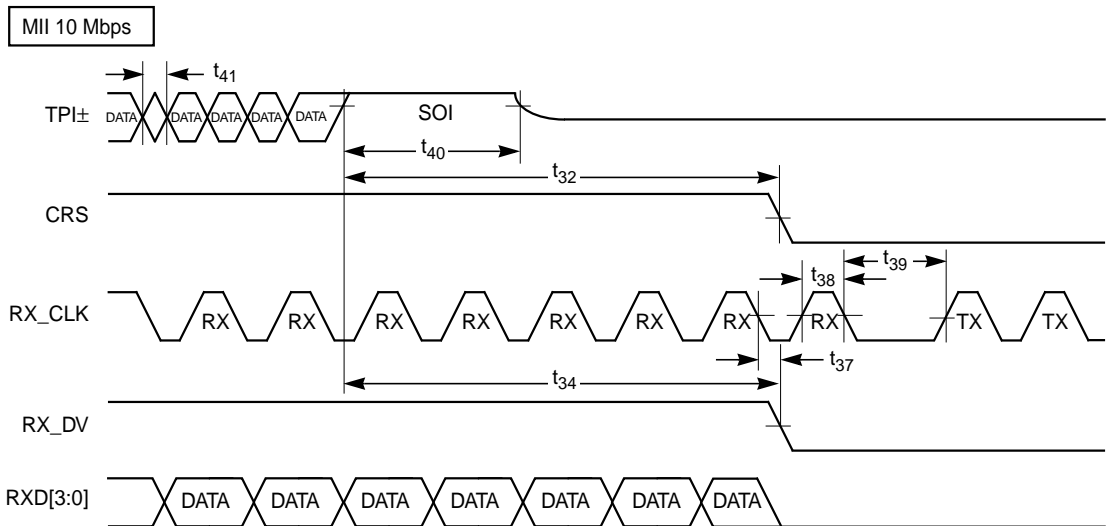
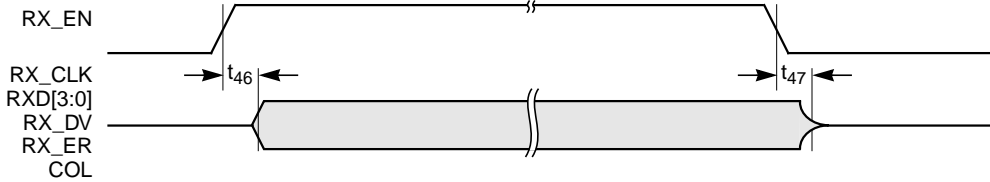

Figure 23 RX_EN Timing



6.9 Collision and Jam Timing Characteristics

Refer to [Figure 24](#), [Figure 25](#), and [Figure 26](#) for Timing Diagrams.

Sym.	Parameter	Limit			Unit	Conditions
		Min	Typ	Max		
t ₅₁	Rcv Packet Start to COL Assert Time			200	ns	100 Mbps
				700	ns	10 Mbps
t ₅₂	Rcv Packet Stop to COL Deassert Time	130		240	ns	100 Mbps
				300	ns	10 Mbps
t ₅₃	Mt Packet Start to COL Assert Time			200	ns	100 Mbps
				700	ns	10 Mbps
t ₅₄	Xmt Packet Stop to COL Deassert Time			240	ns	100 Mbps
				300	ns	10 Mbps
t ₅₅	C_LED Delay Time			25	ms	C_LED
t ₅₆	C_LED Pulse Time	80		105	ms	C_LED
t ₅₇	Collision Test Assert Time			5120	ns	
t ₅₈	Collision Test Deassert Time			40	ns	
t ₆₀	COL Rise and Fall Time			10	ns	

Figure 24 Collision Timing, Receive

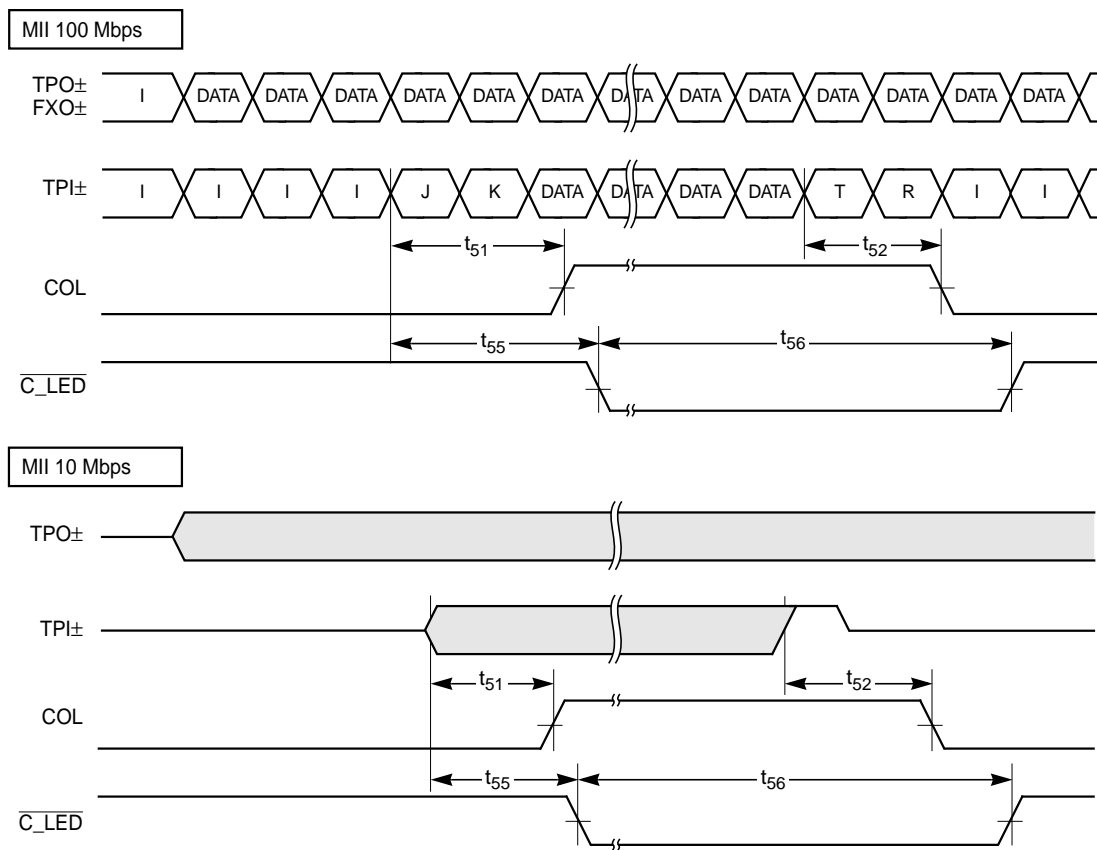

Figure 25 Collision Timing, Transmit

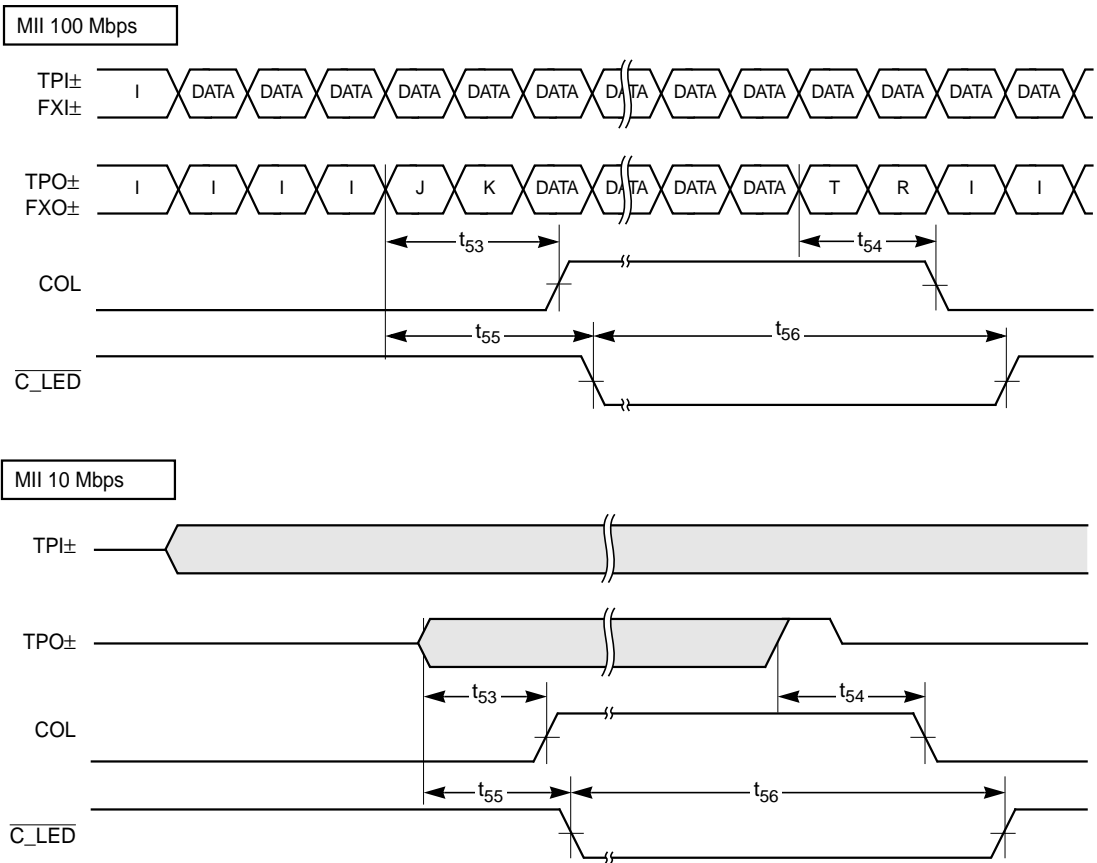
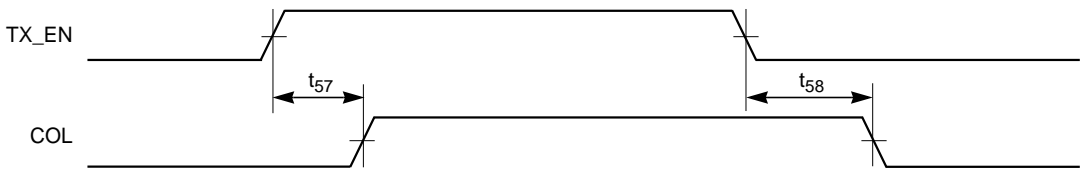

Figure 26 Collision Test Timing



6.10 Link Pulse Timing Characteristics

Refer to [Figure 27](#) and [Figure 28](#) for Timing Diagrams.

Sym.	Parameter	Limit			Unit	Conditions
		Min	Typ	Max		
t ₆₁	NLP Transmit Link Pulse Width	See Figure 7			ns	
t ₆₂	NLP Transmit Link Pulse Period	8		24	ms	
t ₆₃	NLP Receive Link Pulse Width Required For Detection	50			ns	
t ₆₄	NLP Receive Link Pulse Minimum Period Required For Detection	6		7	ms	link_test_min
t ₆₅	NLP Receive Link Pulse Maximum Period Required For Detection	50		150	ms	link_test_max
t ₆₆	NLP Receive Link Pulses Required To Exit Link Fail State	3	3	3	Link Pulses	lc_max
t ₆₇	FLP Transmit Link Pulse Width	100		150	ns	
t ₆₈	FLP Transmit Clock Pulse To Data Pulse Period	55.5	62.5	69.5	μs	interval_timer
t ₆₉	FLP Transmit Clock Pulse To Clock Pulse Period	111	125	139	μs	
t ₇₀	FLP Transmit Link Pulse Burst Period	8		22	ms	transmit_link_burst_timer
t ₇₁	FLP Receive Link Pulse Width Required For Detection	50			ns	
t ₇₂	FLP Receive Link Pulse Minimum Period Required For Clock Pulse Detection	5		25	μs	flp_test_min_timer
t ₇₃	FLP Receive Link Pulse Maximum Period Required For Clock Pulse Detection	165		185	μs	flp_test_max_timer
t ₇₄	FLP Receive Link Pulse Minimum Period Required For Data Pulse Detection	15		47	μs	data_detect_min_timer
t ₇₅	FLP Receive Link Pulse Maximum Period Required For Data Pulse Detection	78		100	μs	data_detect_max_timer
t ₇₆	FLP Receive Link Pulses Required To Detect Valid FLP Burst	17		17	Link Pulses	

Sym.	Parameter	Limit			Unit	Conditions
		Min	Typ	Max		
t ₇₇	FLP Receive Link Pulse Burst Minimum Period Required For Detection	5		7	ms	nlp_test_min_timer
t ₇₈	FLP Receive Link Pulse Burst Maximum Period Required For Detection	50		150	ms	nlp_test_max_timer
t ₇₉	FLP Receive Link Pulses Bursts Required To Detect AutoNegotiation Capability	3	3	3	Link Pulse	
t ₈₀	FLP Receive Acknowledge Fail Period	1200		1500	ms	
t ₈₁	FLP Transmit Renegotiate Link Fail Period	1200		1500	ms	break_link_timer
t ₈₂	NLP Receive Link Pulse Maximum Period Required For Detection After FLP Negotiation Has Completed	750		1000	ms	link_fail_inhibit_timer

Figure 27 NLP Link Pulse Timing

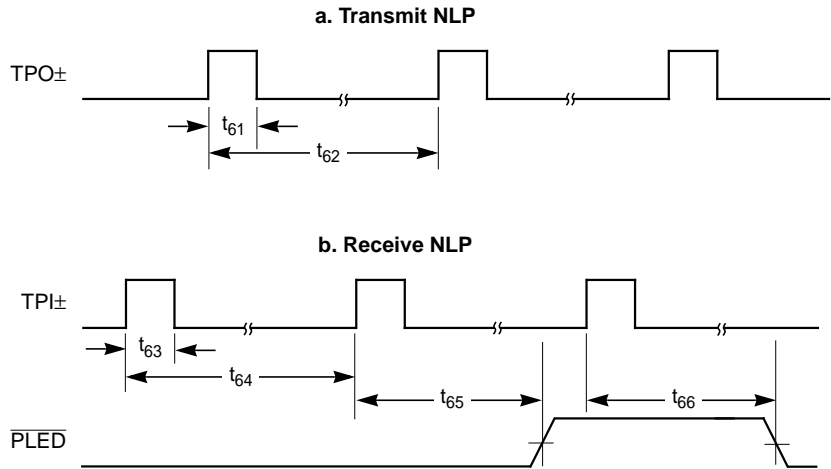
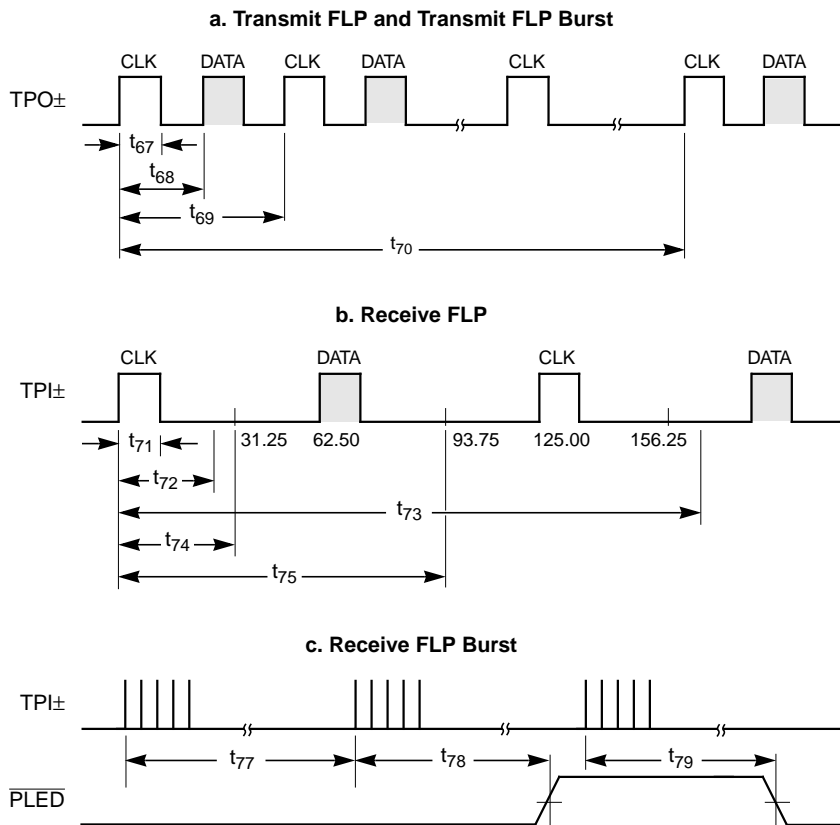

Figure 28 FLP Link Pulse Timing



6.11 Jabber Timing Characteristics

Refer to [Figure 29](#) for Timing Diagram.

Sym.	Parameter	Limit			Unit	Conditions
		Min	Typ	Max		
t ₉₁	Jabber Activation Delay Time	50		100	ms	10 Mbps
t ₉₂	Jabber Deactivation Delay Time	250		750	ms	10 Mbps

Figure 29 Jabber Timing

MII 100 Mbps Not applicable

MII 10 Mbps

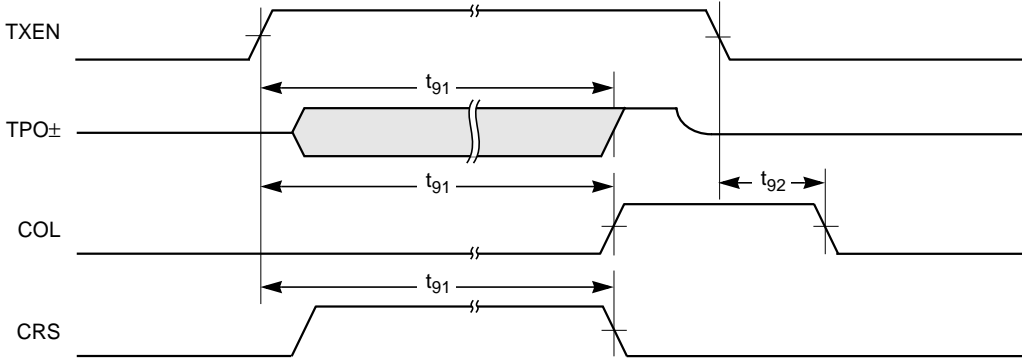

6.12 MI Serial Port Timing Characteristics

Refer to [Figure 30](#) for Timing Diagrams.

Sym.	Parameter	Limit			Unit	Conditions
		Min	Typ	Max		
t_{101}	MDC High Time	20			ns	
t_{102}	MDC Low Time	20			ns	
t_{103}	MDIO Setup Time	10			ns	Write Bits
t_{104}	MDIO Hold Time	10			ns	Write Bits
t_{105}	MDC To MDIO Delay			20	ns	Read Bits
t_{106}	MDIO Hi-Z To Active Delay			20	ns	Write-Read bit transition
t_{107}	MDIO Active To HI-Z Delay			20	ns	Read-Write bit transition
t_{108}	Frame Delimiter (Idle)	32			Clocks	# of consecutive MDC clocks with MDIO=1

Figure 30 MI Serial Port Timing

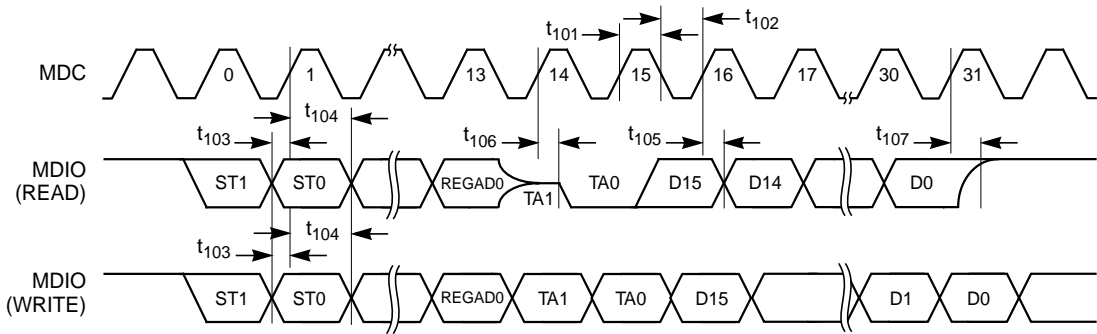

7 Ordering Information

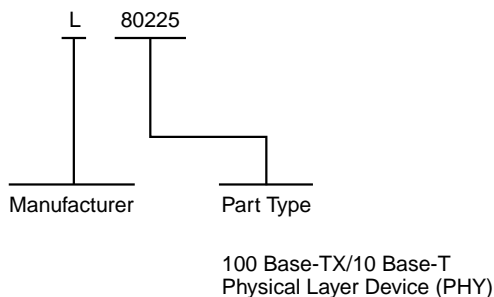

8 Revision History

1/15/99

- Changed document number to MD4000182/A.

1/25/99

[page 5](#): Pin Description

- Pin # 8; 1 = No Link Detect or Activity, has been changed to 1 = No Link Detect

[page 6](#): Pin Description

- Pin # 6; Copy change, This pin can drive an LED from both VDD and GND. has been changed to, This pin can drive an LED from VDD.
- Pin # 6; 0 = Full Duplex, has been changed to, 0 = Full Duplex Mode Detect with Link Pass
- Pin # 5; Copy change, ... function of this pin is to be a 10/100 Mbps Link Detect output... has been changed to...function of this pin is to be a 10/100 Mbps Detect output..
- Pin # 5; Copy change, This pin can drive an LED from both VDD and GND. has been changed to, This pin can drive an LED from VDD.
- Pin #5; 0, has been changed to, 0 = 100 Mbit Mode Detected with Link Pass, 1, has been changed to 1 = 10 Mbit Mode Detected
- Pin # 23; I Pulldown has been changed to I.

[page 7: Pin Description](#)

- Pin #40: ANEG Speed Duplex modes, 1 1 0 Mode Description has been replaced with 1 1 1 Mode Description , Mode 1 1 1 Description has been replaced with 1 1 0 Mode Description.

[page 8: Figure 1. Block Diagram](#)

- Reference to $\overline{\text{MDA4}}$ has been deleted
- Reference to VDD[6:1] has been changed to VDD[4:1].

[page 29: Section 3.14.1, "General."](#)

- Paragraph #3 has been deleted.

[page 31: Section 3.14.9, "Link Indication."](#)

- Paragraph #1 copy change, ...transistors in addition to a weak pullup resistor, so it can drive... has been changed to ...transistors in addition to a weak pullup resistor. Since this LED is shared with...

[page 34: Section 3.17.3, "Full Duplex Indication."](#)

- Paragraph #1 copy change, ...transistors and a weak pullup resistor, so it can drive... has been changed to... transistors and a weak pullup resistor. Since these two LEDs also share their outputs with the address inputs, they should be driven only from Vdd.

[page 36: Section 3.22, "LED Drivers."](#)

- Paragraph #1 copy change, ...pullup and pulldown driver transistors with a pullup resistor so... has been changed to ... pullup and pulldown driver transistors. Since these two LEDs also share their outputs with the address inputs, they should be driven only from Vdd.
- [Table 3](#). LED Event Definition: deleted XMT ACT and RCV ACT.

[page 50: Table 12 MI Register 18 \(Status Output\) Structure and Bit Definition](#)

- [Table 12](#) has been added to the Data Sheet

[page 56: Table 14 TP Transformer Sources](#)

- Vendor BEL, Part Number is now, S558-5999-J9, 558-5999-46

- Vendor HALO, Part Number is now, TG22-3506ND, TG110-S050N2
- Vendor PCA, Part Number is now, EPF8017GH
- **Note:** H1089, S558-5999-46, EPF8017GH, and TG22-3506ND are pin compatible. Please contact the transformer vendor for additional information... has been added.

page 57: Section 5.6.2, "Clocks."

- Paragraph #2 copy change, ... optional 50K resistor to GND. LA_LED should always be tied through a 50K resistor to GND since it has both pullup and pulldown capability. has been changed to ... optional 50K resistor to GND. $\overline{\text{FD_LED}}$ & $\overline{\text{L_LED}}$ should always be tied through a 50K resistor to GND since they have both pullup and pulldown capability.

page 63: Section 5.10, "LED Drivers."

- Paragraph #1 sentence ... In addition, FD_LED ... as well as VDD. ..has been deleted. Paragraph #3 has been deleted.

4/2002

- Changed document number to MD4000182/B.
- Reformatted document with a standard LSI template.
- All references to SEEQ have been removed.
- All "80225" were changed to "L80225."
- Renumbered Tables 7 thru 12a to Tables 6 thru 12. (Table sequence skipped a number in previous version of document, because Table 6 had been deleted.)
- Renumbered Section 5.7.3 (Serial Port Addressing) to Section 5.7.2. (Numbering sequence in previous version of document was incorrect - 5.7.1 followed by 5.7.3.)
- Renumbered Section 5.8.4 (Serial Port Addressing) to Section 5.8.2. (Numbering sequence in previous version of document was incorrect - 5.8.1 followed by 5.8.4.)
- Renumbered Figures 28 thru 31 to Figures 27 thru 30. (There was no Figure 27 in previous version of document.)
- Updated all section, table, and figure cross-references throughout the document.

9 Surface Mount Packages

Figure 31 44-Pin Plastic Leaded Chip Carrier

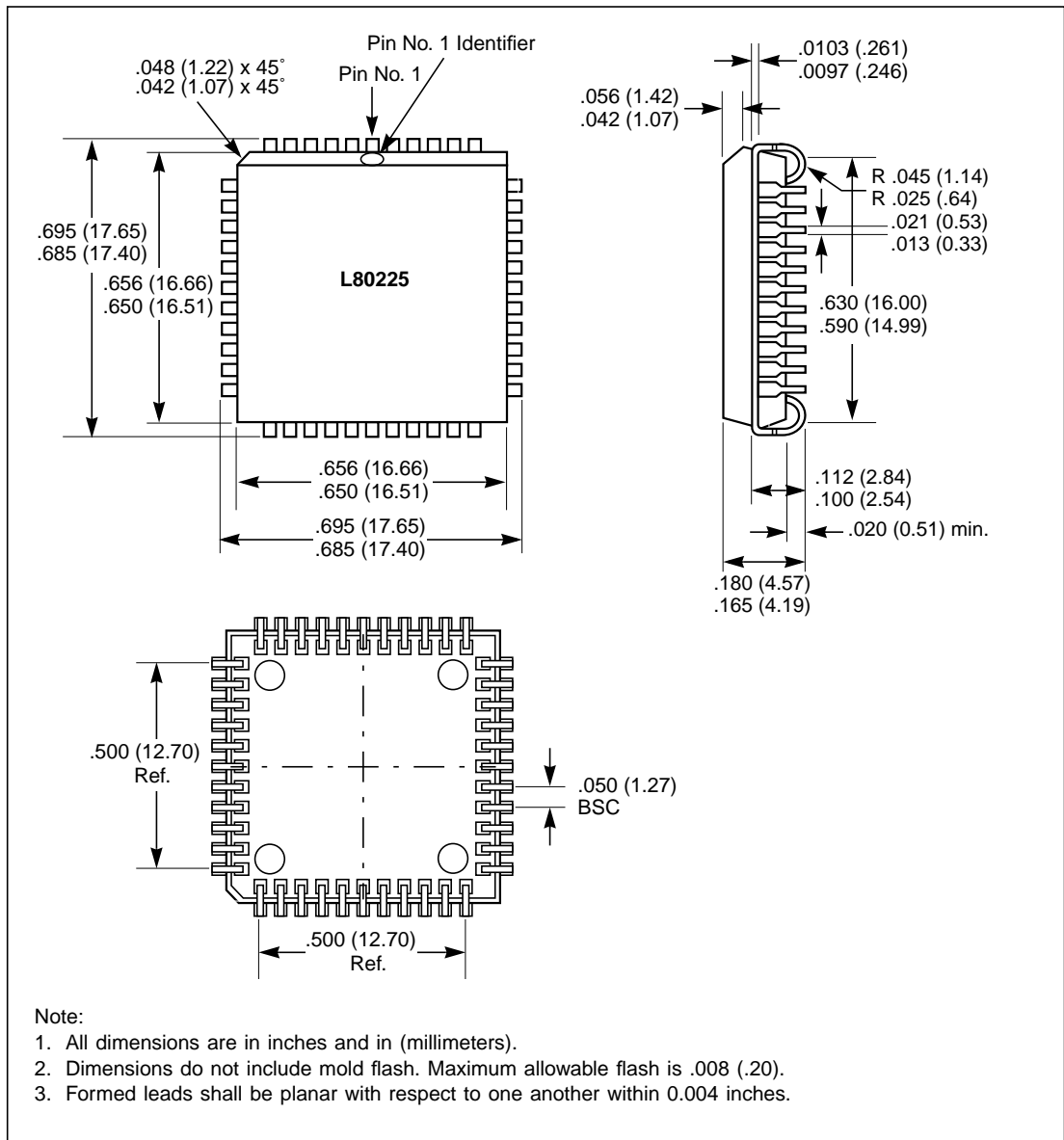

Important: This drawing may not be the latest version.

Headquarters

LSI Logic Corporation
North American Headquarters
Milpitas CA
Tel: 408.433.8000
Fax: 408.433.8989

LSI Logic Europe Ltd
European Headquarters
Bracknell England
Tel: 44.1344.426544
Fax: 44.1344.481039

LSI Logic K.K.
Headquarters
Tokyo Japan
Tel: 81.3.5463.7821
Fax: 81.3.5463.7820

Visit us at our web site: <http://www.lsilogic.com>

ISO 9000 Certified

The LSI Logic logo design is a registered trademark of LSI Logic Corporation. All other brand and product names may be trademarks of their respective companies.

LSI Logic Corporation reserves the right to make changes to any products and services herein at any time without notice. LSI Logic does not assume any responsibility or liability arising out of the application or use of any product or service described herein, except as expressly agreed to in writing by LSI Logic; nor does the purchase, lease, or use of a product or service from LSI Logic convey a license under any patent rights, copyrights, trademark rights, or any other of the intellectual property rights of LSI Logic or of third parties.

Doc. No. MD400182/B
