

isc Silicon NPN RF Transistor

BFR520

DESCRIPTION

- High Power Gain
- High Current Gain Bandwidth Product
- Low Noise Figure

APPLICATIONS

- Designed for RF frontend in wideband applications in the GHz range, such as analog and digital cellular telephones, cordless.

ABSOLUTE MAXIMUM RATINGS(T_a=25°C)

SYMBOL	PARAMETER	VALUE	UNIT
V _{CBO}	Collector-Base Voltage	20	V
V _{CES}	Collector-Emitter Voltage	15	V
V _{EBO}	Emitter-Base Voltage	2.5	V
I _c	Collector Current-Continuous	70	mA
P _c	Collector Power Dissipation @T _c =25°C	0.3	W
T _J	Junction Temperature	175	°C
T _{stg}	Storage Temperature Range	-65~150	°C

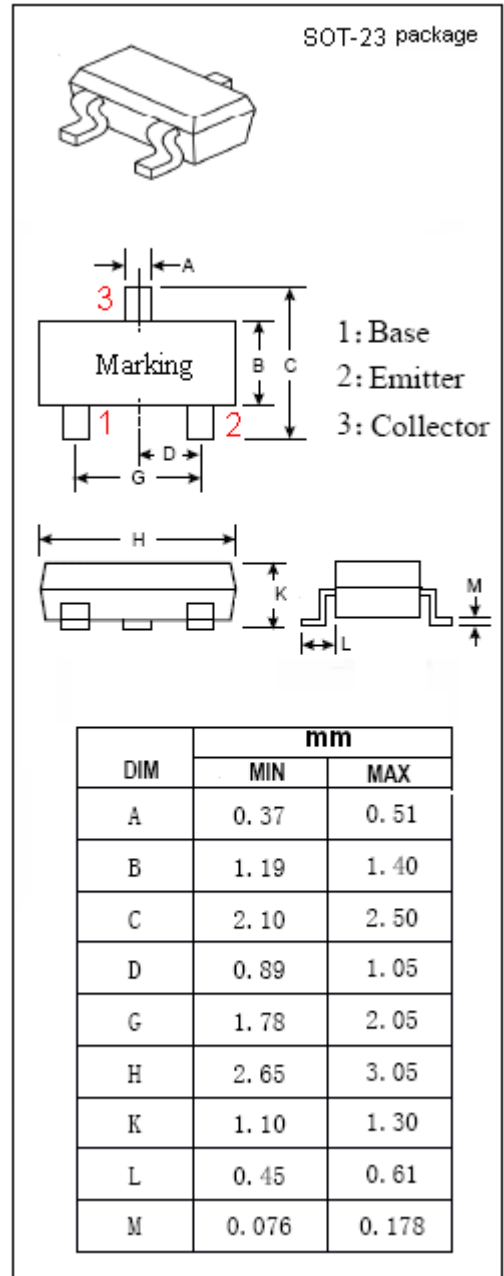

isc Silicon NPN RF Transistor

BFR520

ELECTRICAL CHARACTERISTICS

T_c=25°C unless otherwise specified

SYMBOL	PARAMETER	CONDITIONS	MIN	TYP.	MAX	UNIT
I _{CBO}	Collector Cutoff Current	V _{CB} = 6V; I _E = 0			0.05	μ A
h _{FE}	DC Current Gain	I _C = 20mA ; V _{CE} = 6V	60		250	
f _T	Current-Gain—Bandwidth Product	I _C = 20mA ; V _{CE} = 6V; f= 1GHz		9		GHz
C _{OB}	Output Capacitance	I _E = 0 ; V _{CB} = 6V; f= 1MHz		0.5		pF
PG	Power Gain	I _C = 20mA ; V _{CE} = 6V; f= 900MHz		15		dB
PG	Power Gain	I _C = 20mA ; V _{CE} = 6V; f= 2GHz		9		dB
S _{21e} ²	Insertion Power Gain	I _C = 20mA ; V _{CE} = 6V; f= 900MHz	13	14		dB
NF	Noise Figure	I _C = 5mA ; V _{CE} = 6V; f= 900MHz		1.1	1.6	dB
NF	Noise Figure	I _C = 20mA ; V _{CE} = 6V; f= 900MHz		1.6	2.1	dB

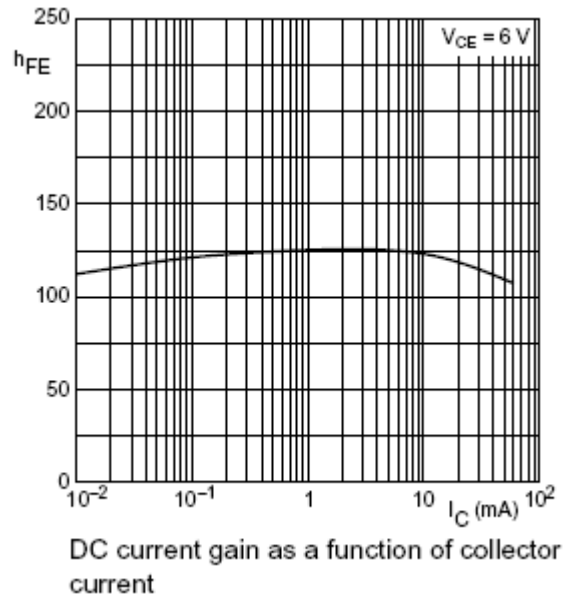
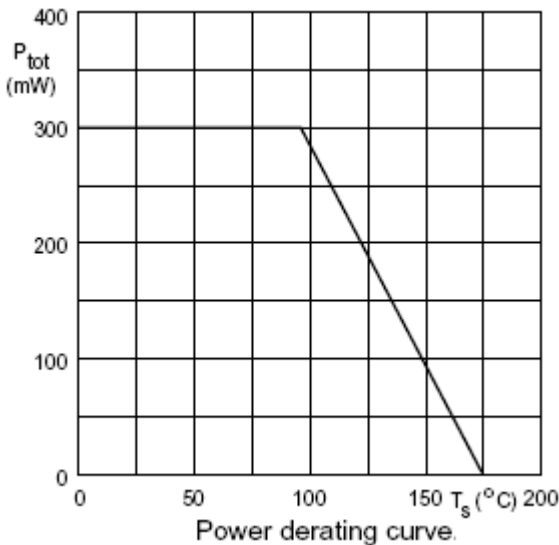

isc Silicon NPN RF Transistor

BFR520

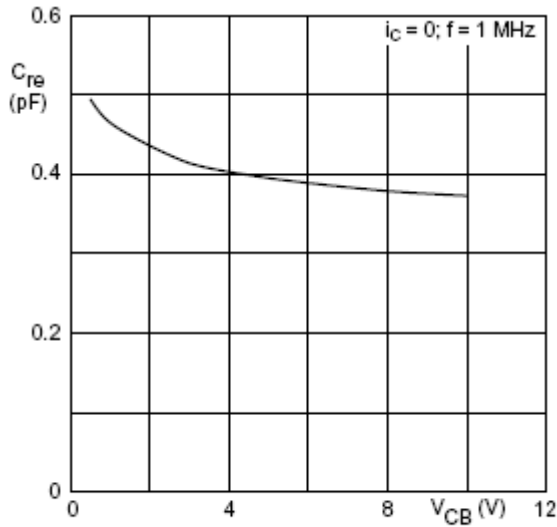

Feedback capacitance as a function of collector-base voltage

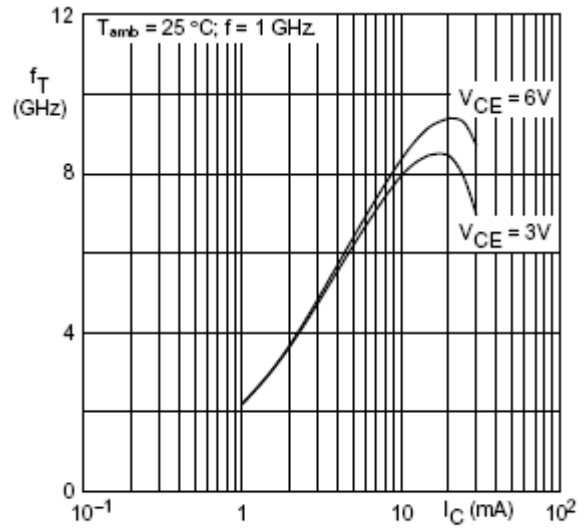

Transition frequency as a function of collector current

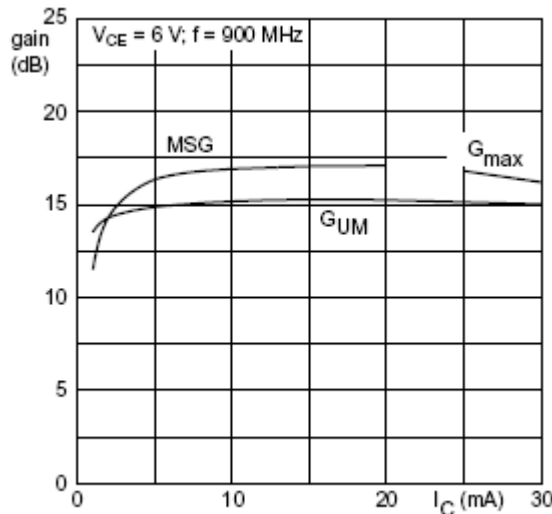

Gain as a function of collector current

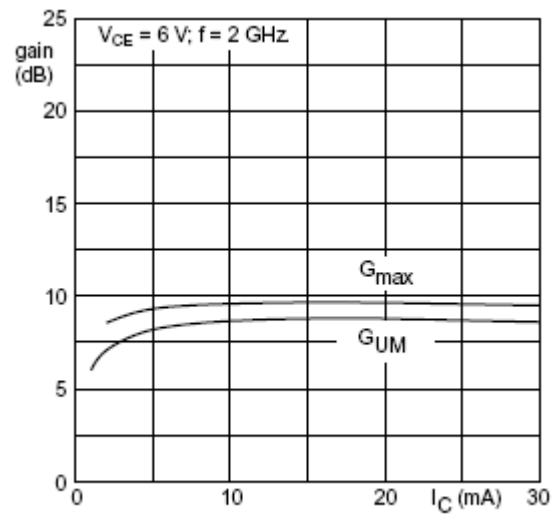

Gain as a function of collector current

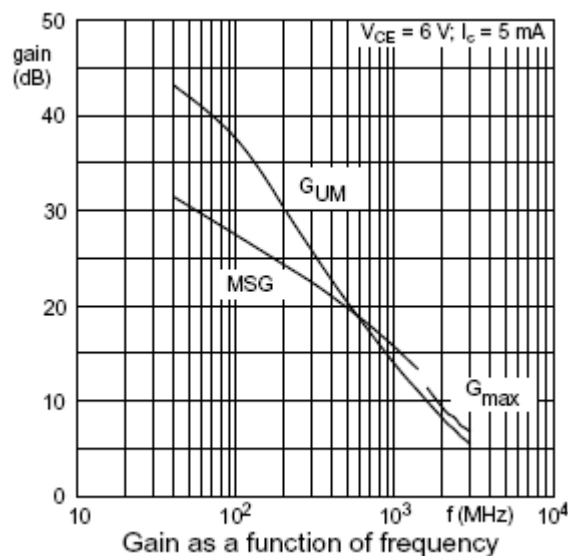

Gain as a function of frequency

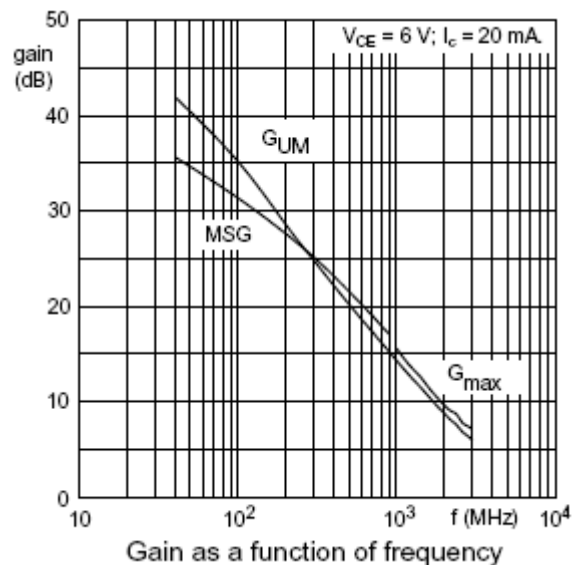

Gain as a function of frequency

isc Silicon NPN RF Transistor

BFR520

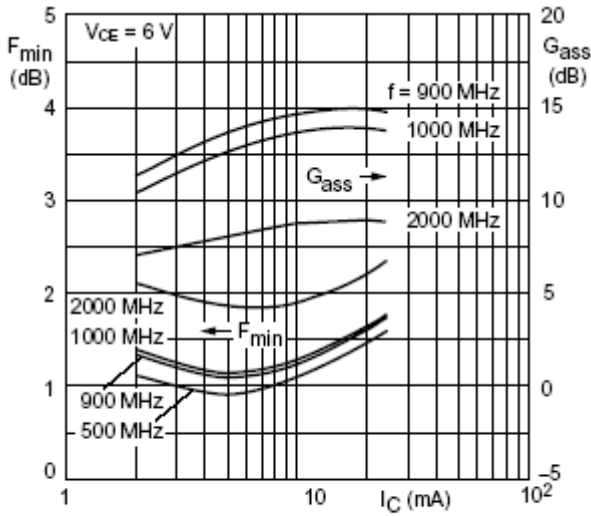

Minimum noise figure and associated available gain as functions of collector current

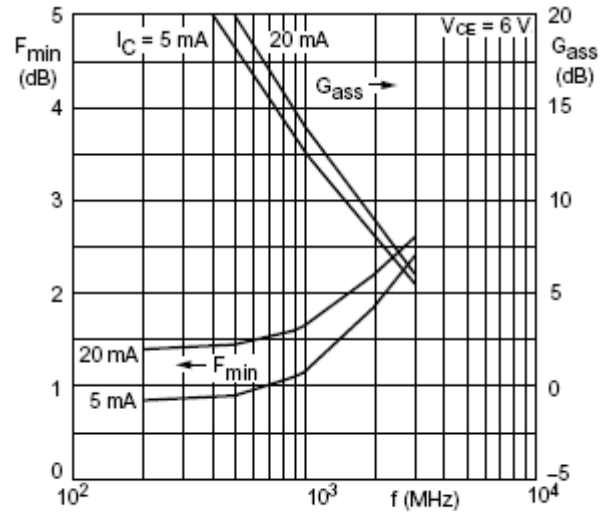

Minimum noise figure and associated available gain as functions of frequency

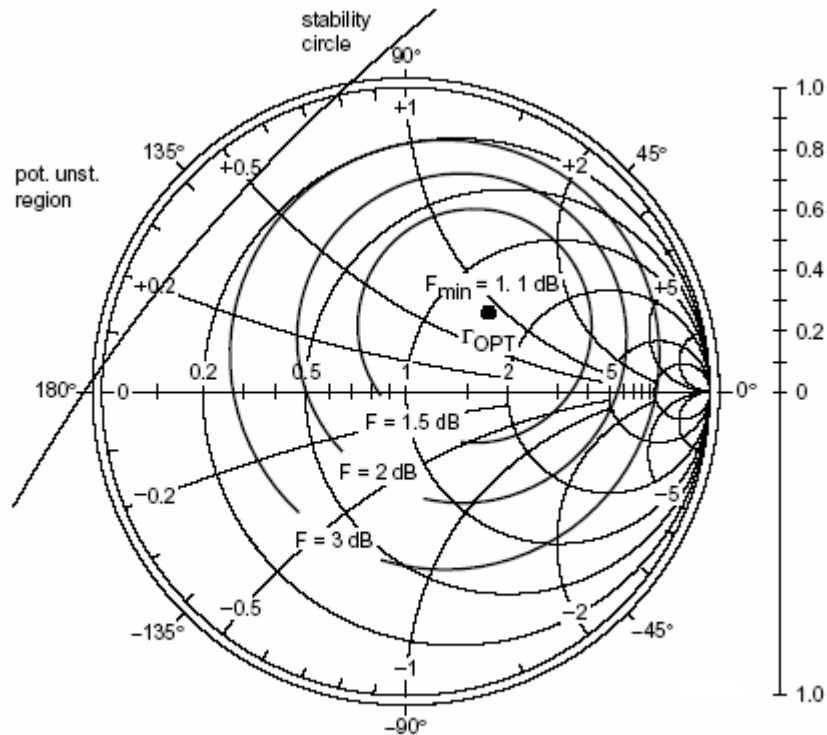

$Z_0 = 50 \Omega$.
 $V_{CE} = 6V$; $I_C = 5mA$; $f = 900MHz$.

Noise circle figure.

isc Silicon NPN RF Transistor

BFR520

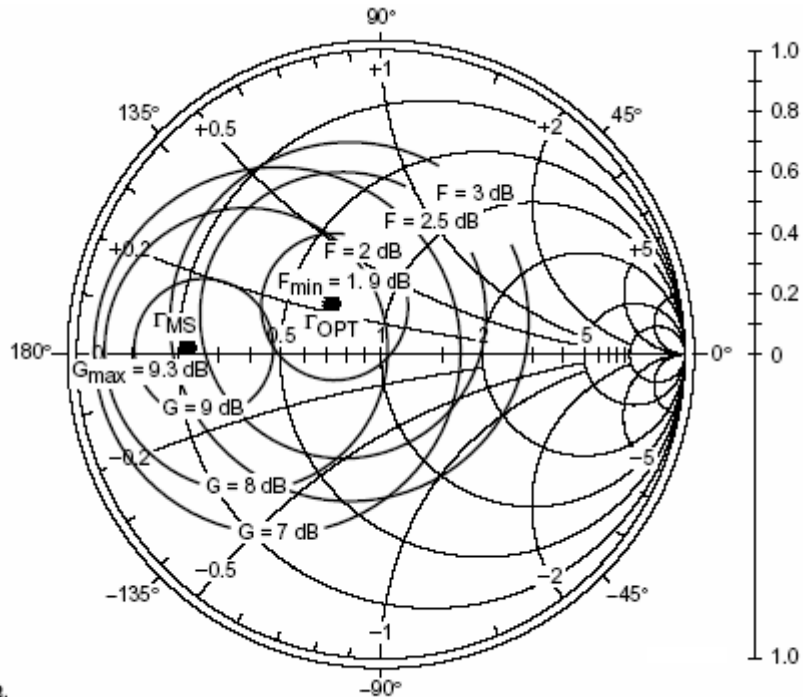

$Z_o = 50 \Omega$.
 $V_{CE} = 6 V$; $I_C = 5 mA$; $f = 2000 MHz$ Noise circle figure.

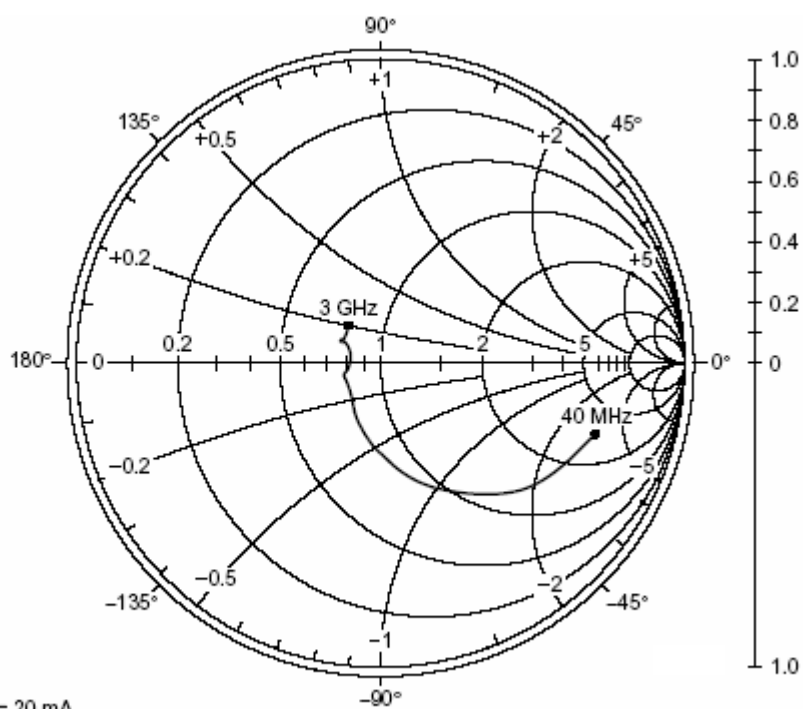

$V_{CE} = 6 V$; $I_C = 20 mA$
 $Z_o = 50 \Omega$. Common emitter input reflection coefficient (S_{11})

isc Silicon NPN RF Transistor

BFR520

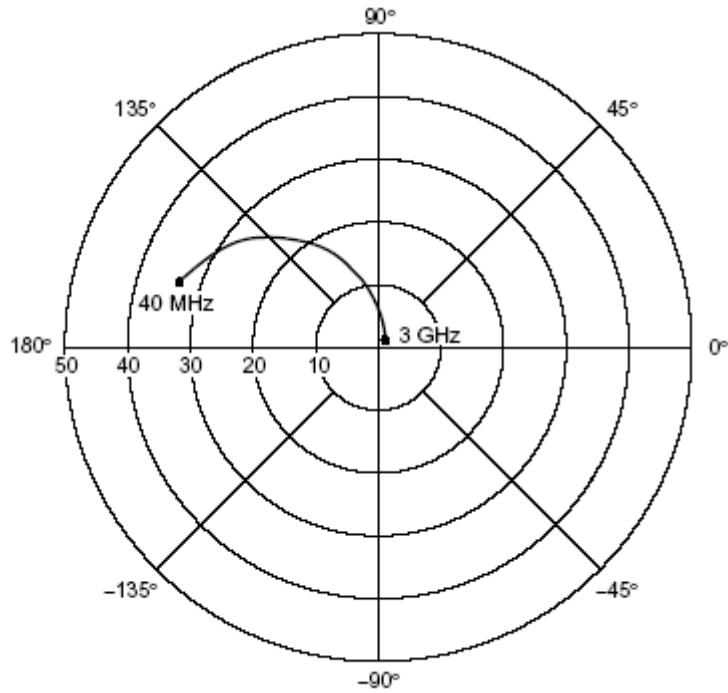

V_{CE} = 6 V; I_C = 20 mA Common emitter forward transmission coefficient (S₂₁)

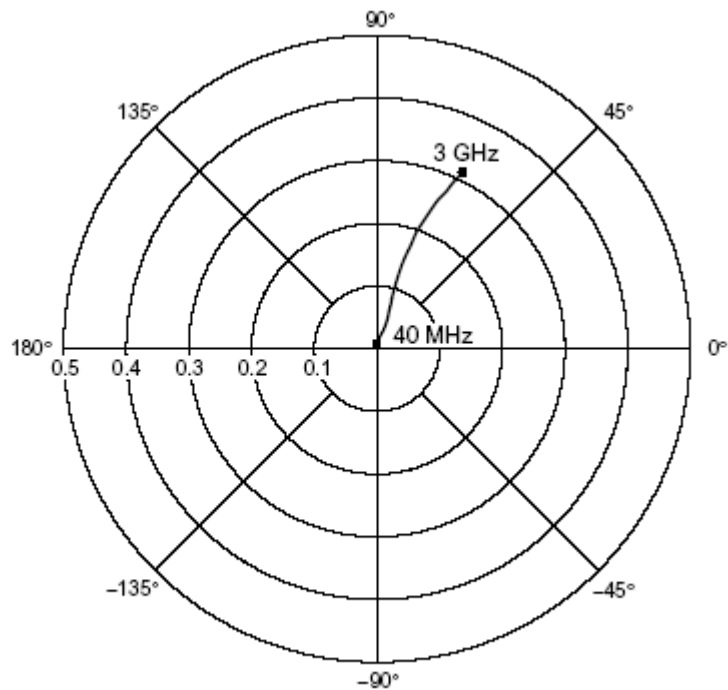

V_{CE} = 6 V; I_C = 20 mA Common emitter reverse transmission coefficient (S₁₂)

isc Silicon NPN RF Transistor

BFR520

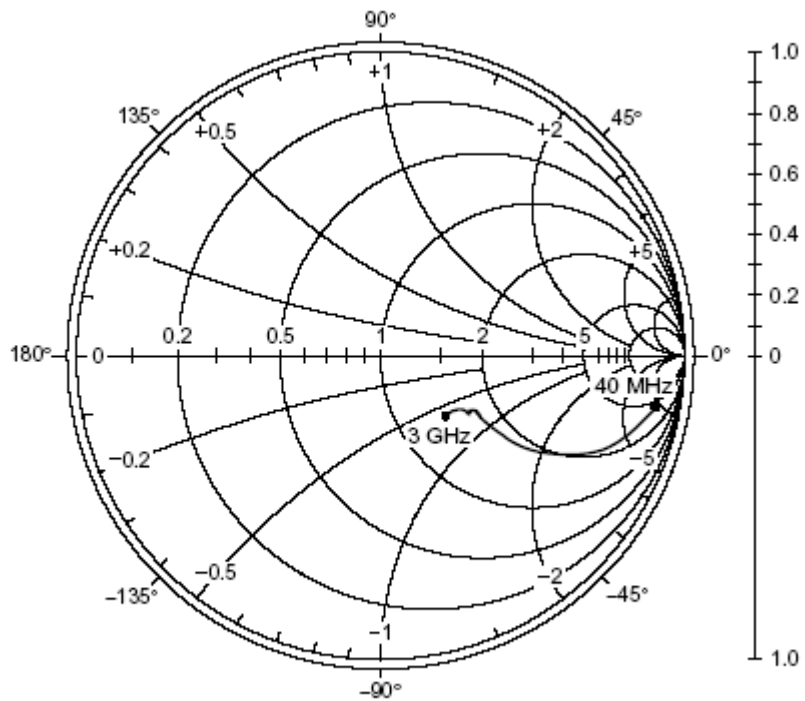

$V_{CE} = 6\text{ V}$; $I_C = 20\text{ mA}$ Common emitter output reflection coefficient (S_{22})
 $Z_o = 50\ \Omega$.