



MACHINERY SAFETY SYSTEMS

**1K3 SERIES
SAFETY LIGHT CURTAINS**

INSTALLATION GUIDE

Smartsan Ltd
Pywell Road
Willowbrook Industrial Estate
Corby
Northamptonshire
NN17 5XJ - England

Tel. +44 (0)1536 – 401 313
sales@smartsan.co.uk
www.smartsan.co.uk

Important!

Failure to read and follow the instructions provided on the Installation Sheet and Installation Guide can lead to the incorrect application or use of the 1K3 series safety light curtain. This could lead to personal injury and damage to equipment. All applicable machine safety standards and regulations should be taken into account when installing the 1K3 series safety light curtain or any machine safety product.

The Installation Sheet and Installation Guide can be downloaded from our web site at www.smartsan.co.uk

The 1K3 series Safety Light Curtain Installation Guide (CD701) is subject to change without notice. Smartsan Ltd shall not be held responsible for technical errors, editorial errors or omissions contained herein, nor for incidental or consequential damages resulting from the use of this material.

© 2020 Smartsan Ltd. All Rights Reserved. Unless explicitly stated otherwise, all rights including those in copyright in the content of this document are owned by or controlled for these purposes by Smartsan Ltd.

Except as otherwise expressly permitted under copyright law or Smartsan Ltd, reproduction of the document or alteration of this document may not be carried out in any way without first obtaining Smartsan Ltd.'s written permission.

CONTENTS

FIGURE A - UNPACKING	1
FIGURE B – OPERATING REQUIREMENTS.....	2
FIGURE C – MOUNTING ARRANGEMENTS.....	3
FIGURE D – DETECTION ZONE, DETECTION CAPABILITY AND RANGE.....	4
FIGURE E – IDENTIFICATION LABELS	4
FIGURE F - IMPORTANT INSTALLATION CONSIDERATIONS.....	5
FIGURE G – MODEL LIST	7
FIGURE H – WIRING CONNECTIONS AND STATUS/DIAGNOSTIC INDICATION	8
POWER SUPPLY	8
AUTOMATIC RESET	9
SAFETY OUTPUTS OSSD1 AND OSSD2	10
LED STATUS INDICATORS	10
FIGURE I – TEST AND MAINTENANCE	11
FIGURE J – OPERATION CYCLE	13
FIGURE K – PRODUCT RETURN PROCEDURE	14
FIGURE L – DECLARATION OF CONFORMITY	15
FIGURE M – GLOSSARY OF WORDS AND LANGUAGE TRANSLATION	16
APPENDIX 1 – IMPORTANT SAFETY INFORMATION.....	17
APPENDIX 2 - CERTIFICATIONS.....	18
APPENDIX 3 - MIRRORS	19
APPENDIX 4 – SPECIFICATION TABLE	23
NOTES	24

1K3 series (Model No. 1K3-xxx) Safety Light Curtain Installation Sheet (CD700/060420)

Figure A - Unpacking

- ❑ Remove all packaging material and retain it
- ❑ Locate and keep the delivery note
- ❑ Inspect all items for transit damage
- ❑ Match goods supplied to those specified on the delivery note
- ❑ Keep the Installation Sheet in a safe place

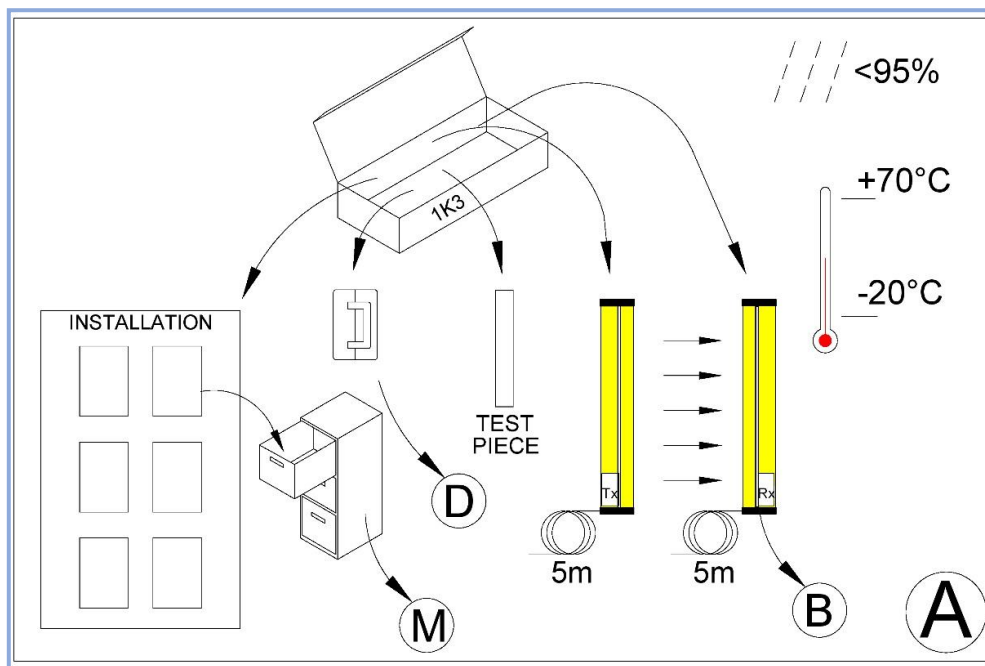

Each 1K3 series supplied would normally include:

- ❑ Safety Light curtain with 5m of cable attached to transmitter and receiver columns
- ❑ Test piece (excluding 1K3 Perimeter options)
- ❑ Installation sheet
- ❑ Ferrite
- ❑ Service questionnaire form

Storage requirements:

- ❑ Humidity - <math><95\%</math>
- ❑ Temperature range between -20°C and $+70^{\circ}\text{C}$

Figure B – Operating Requirements

- ❑ Humidity <95%
- ❑ Temperature range between 0°C and +50°C
- ❑ Vibration: Frequency <55Hz Max. Movement <0.35mm
- ❑ Do not use equipment in explosive atmospheres (contact the manufacturer for further advice).

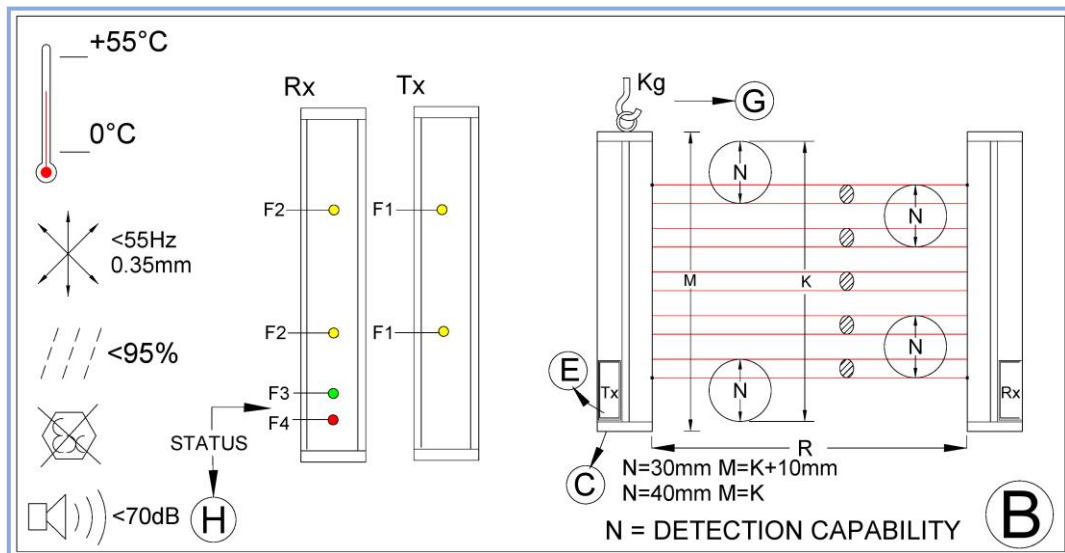

Figure B also describes important parameters associated with the safety light curtain.

M – Overall length of light curtain enclosures

K – Detection zone width

R – Minimum and maximum scanning ranges of the light curtain

N – Object Detection Capability.

(The minimum size of object guaranteed to be detected when placed in the infrared detection zone of the light curtain.)

The position of the status and diagnostic indicators are shown for both the Transmitter head (Tx) F1 and Receiver head (Rx) F2, F3 & F4. See also Figure H.

Figure C – Mounting Arrangements

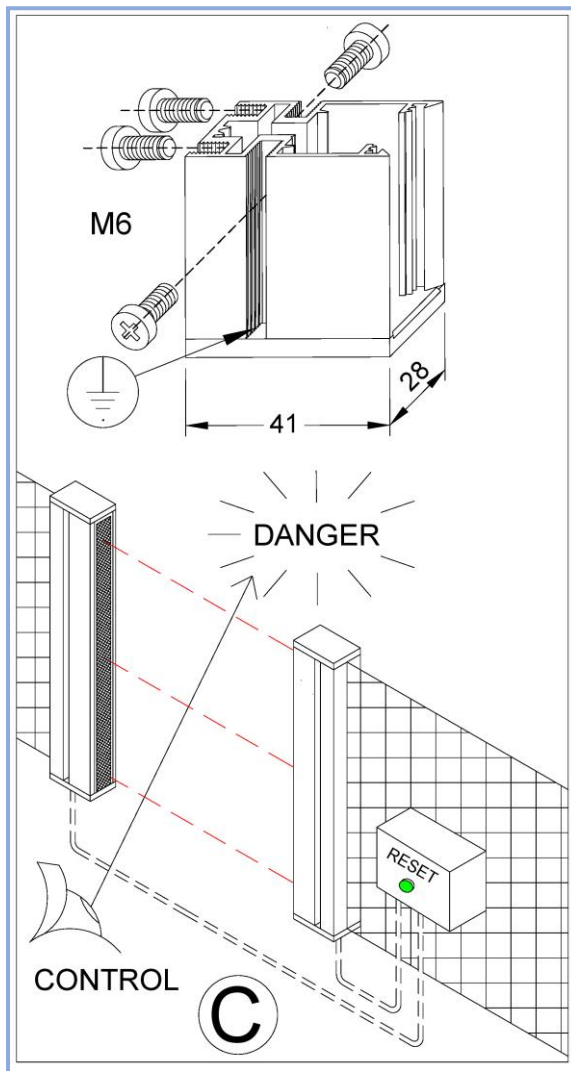

The 1K3 series does not use cable connectors. Both the transmitter and receiver units come complete with 5m cables attached. Transmitter = 2 way cable, Receiver = 4 way cable.

The 1K3 series has a unique mounting arrangement. Threaded slots running from top to bottom of the transmitter and receiver columns enable M6 screws to be affixed at any position along the length of the slot.

The M6 threaded slots run the entire length of the aluminium extrusion, between the two end caps. There is a slot at each side of the extrusion and two slots at the rear as shown in Figure C.

The M6 threaded slot also provides connection point for earthing wire on each head.

The safety light curtain dimensions are, overall length (M) x 28mm width x 41mm depth.

Reset Location

In applications where it is a possible for a person to stand between the safety light curtain and the danger then it is a requirement that the safety outputs cannot be reinstated without the operator first checking that the dangerous area is clear of personnel and therefore safe.

The reset switch must also be located so that the operator cannot reset the light curtain from inside the dangerous area.

Note:

As an additional option a Mounting Bracket Kit (1K3-130) is available.

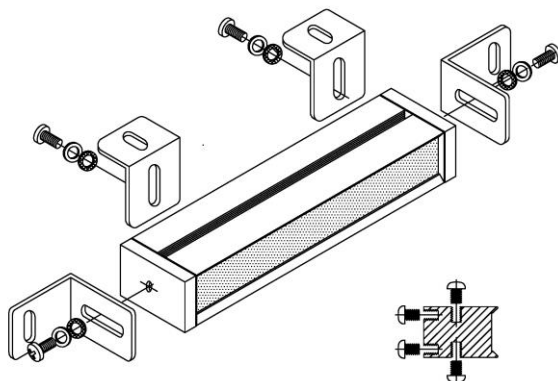
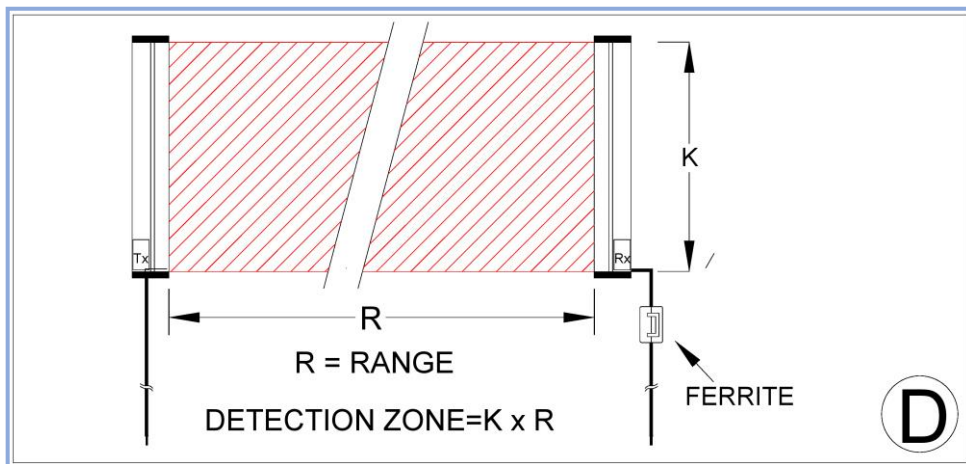

Figure D – Detection Zone, Detection Capability and Range



Detection Zone width (K)

The detection zone width or protected height must be of a suitable size for each application to prevent personnel access to the danger area. This can be over, under or around the light curtain’s detection zone.

Object Detection Capability (ODC) (N)

The minimum size of object guaranteed to be detected when placed in the light curtain’s infrared sensing field. A test piece of appropriate size is provided to test that the light curtain object detection capability is within the parameter specified for the particular model number. Transparent objects are not detected.

Range (R)

This is the maximum scanning range of the light curtain between the Transmitter (Tx) head and Receiver (Rx) head. Ensure the light curtain is capable of satisfying the range requirement for the particular application it is being used for.

A ferrite core is supplied for attachment to the receiver head cable just below the bottom of the light curtain as shown above.

Figure E – Identification Labels

Examples are shown below of the identification labels that are affixed to the bottom of the transmitter (TX) and receiver (RX) columns.

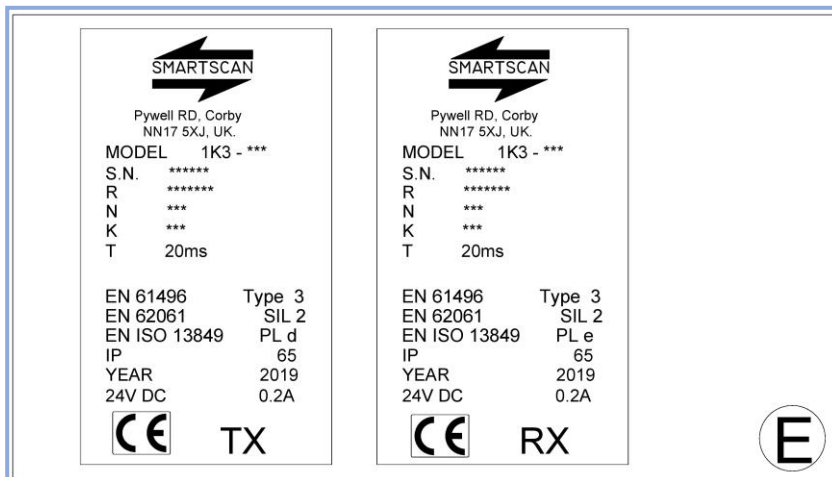
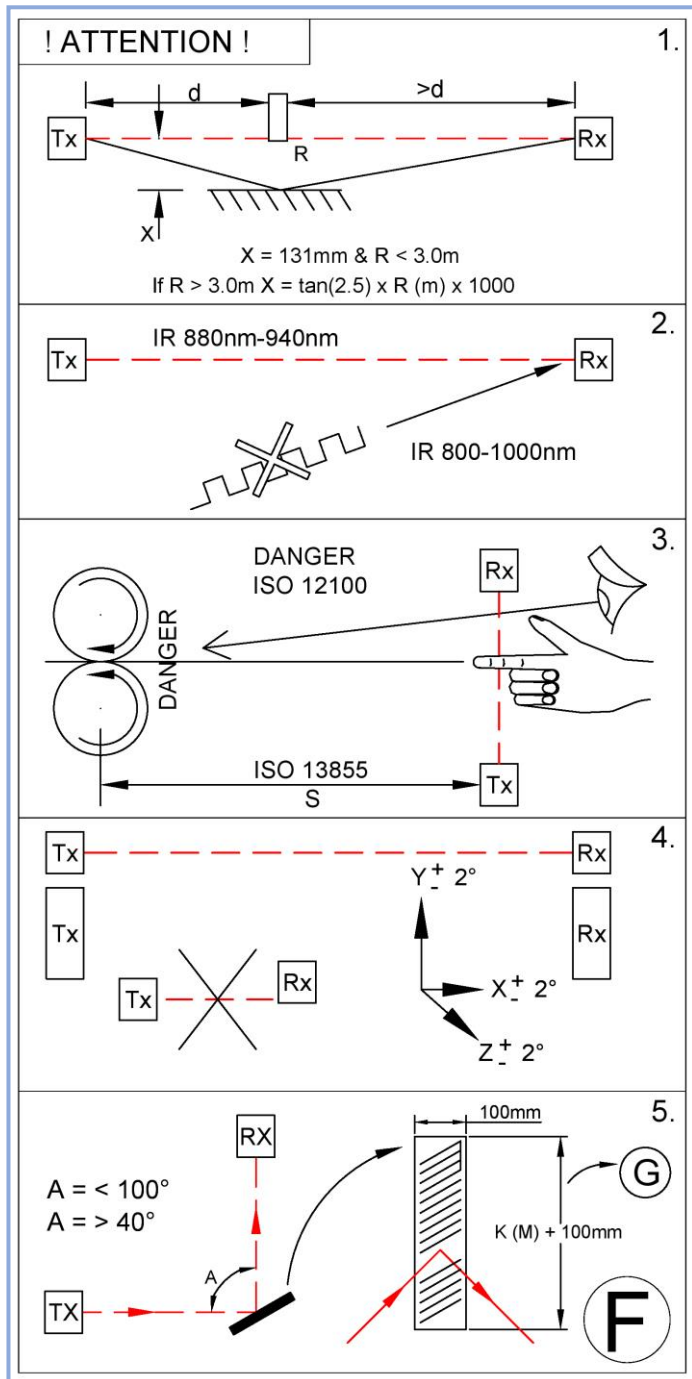

Figure F - Important Installation Considerations

1. Consider reflective surfaces that may give rise to an optical 'short circuit' from the direct path of the safety light curtain's infrared beams as shown in the first illustration of Fig. E. To ensure the safety light curtain is mounted far enough away from reflective surfaces use the formula provided to calculate the minimum distance (X) between the light curtain and reflective surface.



2. To prevent intermittent tripping of the safety light curtain, ensure that extraneous infrared energy between 800 and 1000 nanometres is not directed towards the Perspex window of the receiver unit (Rx). Extraneous sources would include infrared sensors, infrared remote controls, scanning systems or sunlight.

3. Ensure the mounting position of the safety light curtain in respect to the nearest danger point meets the requirements of European Standard ISO 13855. The Separation distance of the safety light

curtain from the danger point of the machine must be met at all times for safe operation. In order for the machine to be guarded by the safety light curtain, the machine must be capable of stopping at any point in the machine cycle.

To prevent personnel from reaching the danger point of the machine additional mechanical guarding may be required so that any access has to be through the sensing field of the safety light curtain. The safety light curtain must be positioned so as to prevent any overreach or under reach to the danger point. If it is possible to stand between the safety light curtain and the danger point

then the latched/manual reset function must be used with the reset being local to the light curtain so the danger area can be seen while resetting and the reset should not be accessible from inside the danger area.

The protection afforded by the safety light curtain should correspond to the machine Risk Assessment under ISO 12100:2010 for the machine being guarded.

4. Ensure the light curtain transmitter (Tx) and receiver (Rx) units are mounted accurately in-line with each other and are both perpendicular and parallel to each other within the parameters shown for each axis.
5. If utilising mirrors to deflect the light curtain ensure the mirror length is 50mm longer at either end of the light curtain detection zone width and mounted centrally to the zone. To ensure reliable operation the light curtain deflection angle (A) from the mirror must not be less than 40 degrees or greater than 100 degrees. (See Appendix 3)

Environmental factors can affect the operation of a safety light curtain and proper consideration should be taken into account for mounting a system where fog, rain, smoke, dust, large temperature fluctuations etc. is a consideration.

Safety light curtains do not protect personnel from chemicals, heat, gases, radiation, flying parts etc. Safety light curtains are not a physical barrier.

The machine operators must be instructed in the use of the safety light curtain by the owner/provider of the machinery.

Figure G – Model List

This shows the 1K3 model list showing part codes, detection zone width (K) and combined weight in Kg of transmitter and receiver columns. A list of the operating ranges for the different model numbers is also provided.

MODEL N=30mm			MODEL N=40mm		
K(mm)	Kg.		K(mm)	Kg.	
180	0.3		190	0.3	
330	0.5		340	0.5	
480	0.7		490	0.7	
630	0.8		640	0.8	
780	0.9		790	0.9	
930	1.1		940	1.1	
1080	1.3		1090	1.3	
1230	1.5		1240	1.5	
1380	1.7		1390	1.7	
1530	1.9		1540	1.9	
1680	2.1		1690	2.1	
1830	2.3		1840	2.3	

MODEL	BEAMS	M(mm)	RANGE	Kg.
1K3-125	2	640	0.5 - 5m	0.7
1K3-126	3	990	0.5 - 5m	0.9
1K3-127	4	1290	0.5 - 5m	1.2
1K3-122	2	640	4 - 10m	0.7
1K3-123	3	990	4 - 10m	0.9
1K3-124	4	1290	4 - 10m	1.2

NOTE: PERIMETER GUARDS HAVE A 6 BEAM UNIT AT THE BEAM LOCATIONS 

N = 30mm R = 0.5 - 5m
 N = 40mm R = 4 - 10m
 PERIMETER R = 0.5 - 5m
 R = 4 - 10m

Figure H – Wiring Connections and Status/Diagnostic Indication

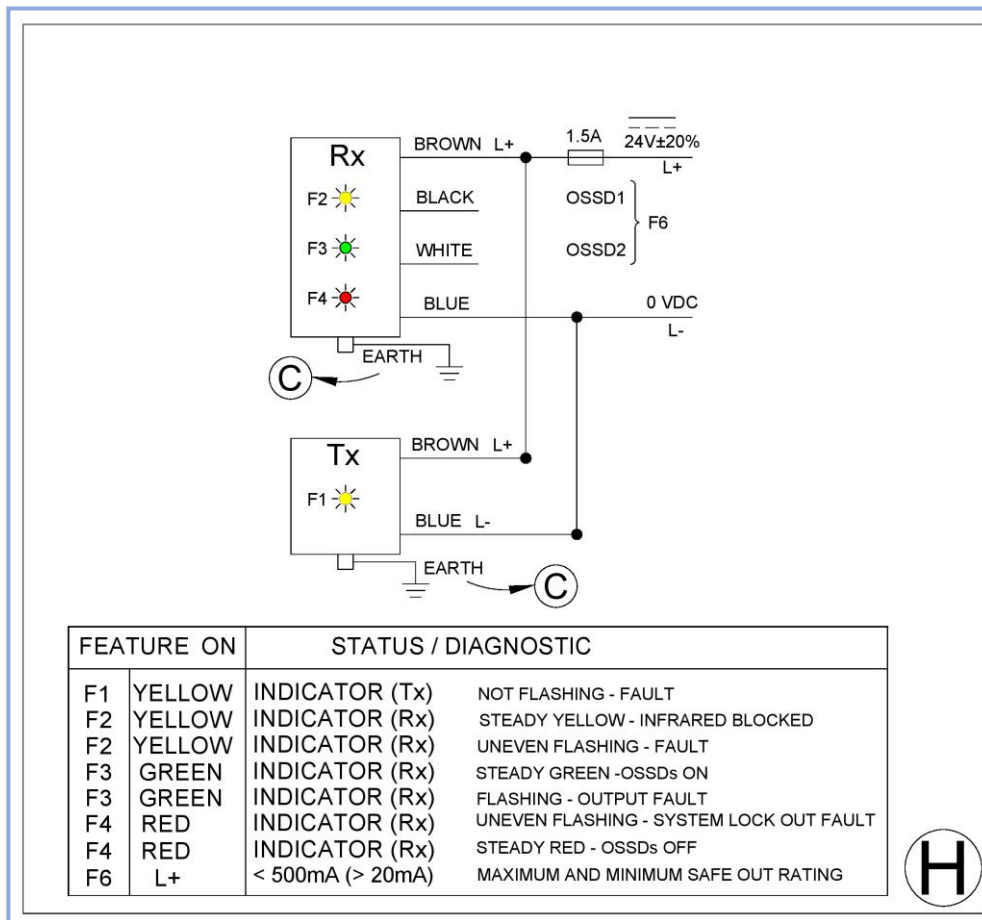

Warning

Any wiring or re-wiring of the safety light curtain must be done with the power supply disconnected.

Any input or output signals that are not being used must be terminated safe.

The machine must be disconnected during electrical installation to ensure no inadvertent start up of the machine occurs.

The connection cables must be not be routed with high-voltage cables, e.g. inverter cables or motor power supplies.

Power Supply

Use a regulated power supply +24V DC ±10% fused at 1.5A for the receiver head and 0.5A for the transmitter head. The transmitter and receiver units operate entirely independently from each other, e.g. there are no electrical connections between the transmitter and receiver units therefore separate 24V DC power supplies may be used if required. In order to protect the 1K3 series electronic

system please remember to install fuses of suitable rating between incoming 24V DC supply and 24V input connections at both the transmitter and receiver units.

The 1K3 light curtain current consumption is rated at 0.5A + load current of the OSSDs. The Brown wire on both the Transmitter (Tx) and Receiver (Rx) head cables must be connected to 24V DC (L+). The Blue wire on both the Transmitter (Tx) and Receiver (Rx) head cables must be connected to 0V DC (L-).

Before power is applied to the light curtain ensure both Tx and Rx heads are aligned correctly.

Ensure both transmitter and receiver units are connected to GROUND. Insert an M6 bolt into one of the threaded slots in the extrusion to ensure a good ground connection.

Warning 0V (L-) of the power supply unit (PSU) must be connected to Earth (PE). No signal should exceed +24V DC $\pm 20\%$ (L+) or be less than 0V (L-)

Warning The shield on both the Transmitter (Tx) and Receiver (Rx) head cables must be connected to Earth (PE).

Note: Prior to initial power up of the unit check the following.

If the Smartsan system is connected directly to a 24V DC source supplied by the user, it must be emphasised that the supply should be regulated and suppressed to prevent transient voltages and other forms of electrical interference from affecting correct operation of the Smartsan equipment.

Ensure the 24V DC source supplied by the user has sufficient current load to satisfy the Smartsan light curtain current consumption requirement, taking into account any other devices already connected to the PSU.

Automatic Reset

The 1K3 series operates in the automatic reset condition.

Applications requiring a manual (latched) reset function are provided by Smartsan's range of multifunction safety relay units (MFUs). They have manual reset, safety relay output, status output, EDM, muting, 2 x safety light curtain connection and many other functions.

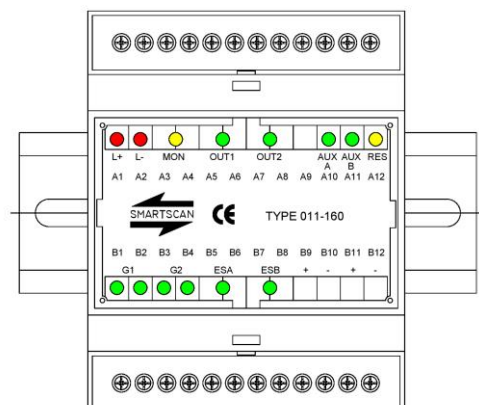

Safety Outputs OSSD1 and OSSD2

Two independent (PNP) electronic switching failsafe signal outputs (OSSDs) are provided for the machine safety circuit. Interruption of the safety light curtains infrared sensing field will cause the OSSDs to go to an OFF state and initiate a machine stop condition.

The connections are provided via the Black wire (OSSD1) and the White wire (OSSD2) on the Receiver (RX) head cable.

Outputs ON = +24V DC (Light curtain clear)
Outputs OFF = 0V DC (Light curtain blocked)

The electronic outputs are monitored and rated at a switching rating of 24V DC, Min. 20mA and Max.500mA. To prevent possible damage never exceed the maximum current rating for the switching devices. LED indicators located on the Receiver (RX) head show the status of the OSSDs.

Note: Inductive load suppressors should be used when driving large power relays.

LED Status Indicators

F1 – If the yellow ‘flashing’ indicators on the transmitter (Tx) column are flashing at an even flash rate the unit is powered-up and the electronic system is operating normally.

F2 – Yellow ‘even-flashing’ indicators on the receiver (Rx) column indicate that communication is established between transmitter and receiver and the light curtain is correctly aligned. Yellow ‘steady’ indicators on the receiver (Rx) column indicate that the light curtain is incorrectly aligned or the light curtain detection zone is ‘blocked’.

F3 – Green LED indicator at the receiver (Rx) column illuminates when the electronic output switches, OSSD1 and OSSD2 are ‘ON’ (only when the light curtain detection zone is ‘clear’ of any obstruction). If the Green LED indicator is flashing this indicates an output fault.

F4 – Red LED indicator at the receiver (Rx) column illuminates when the electronic output switches, OSSD1 and OSSD2 are ‘OFF’ e.g. a trip condition or, when the light curtain detection zone is ‘blocked’. If the Red LED indicator is flashing the system is in lockout. To recover from a lockout condition, disconnect the transmitter and receiver from the power source and then re-apply.

F6 – Output Signal Switching Devices OSSD1 and OSSD2 provide the fail-safe signals for switching a safe, control relay or contactor.

Figure I – Test and Maintenance

Testing the safety light curtain with the test piece

The test procedure should be carried out frequently as indicated by the risk assessment for the particular installation.

A test must be carried out at the initial installation and prior to the machine start-up.

Smartsan Ltd recommends the test should be carried out daily.

Any changes to the configuration of the safety light curtain must be followed by testing to check the system is still working correctly.

Regular function checking of the safety light curtain as well as at initial installation is required as part of the test and maintenance process.

The operating instructions for the safety light curtain and machine must be made available for the operator and those responsible for installation, maintenance and safety control at all times.

To test the safety light curtain, power it up and activate the output switching circuits (OSSDs) to an ON condition.

Insert a test piece of appropriate size into the light curtain detection zone, at the bottom, 150mm from the transmitter unit. At this point the output switches will turn OFF. Sweep the test piece up through the detection zone parallel to the transmitter. Now sweep the test piece down through the detection zone equal distance between the transmitter and receiver. Now sweep the test piece up through the detection zone 150mm and parallel to the receiver unit. At no time during these tests should the output switches turn ON.

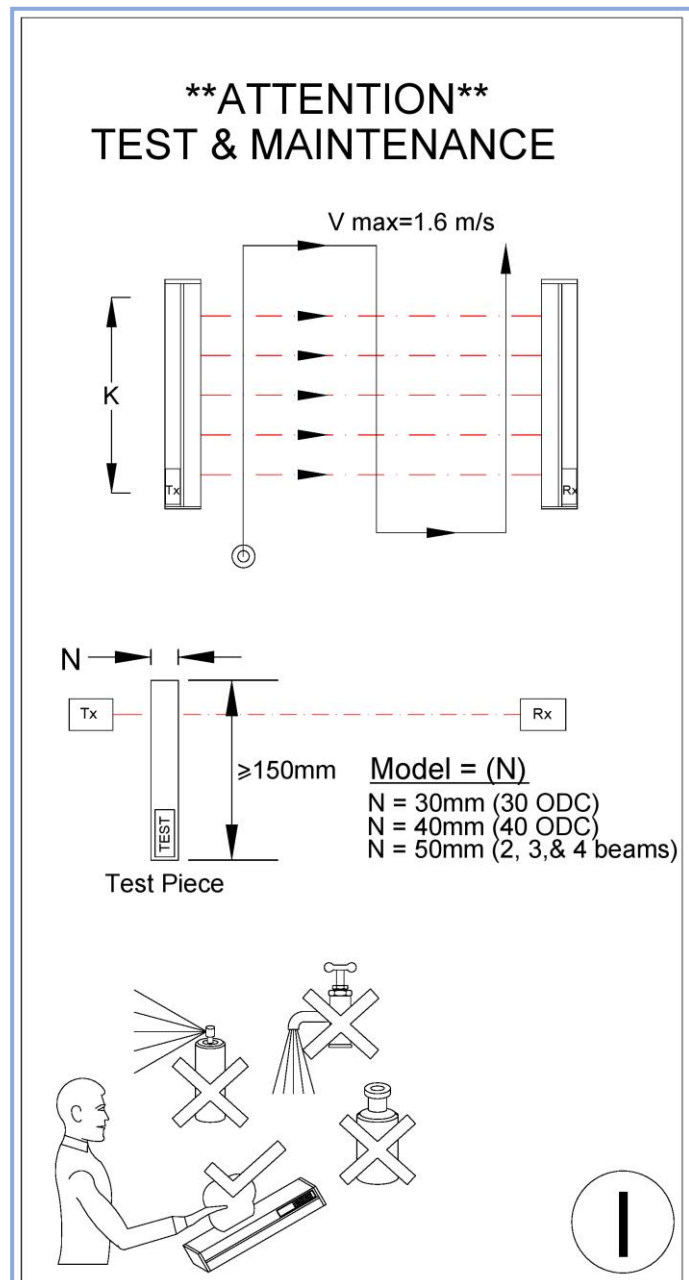

Now thrust the test piece anywhere in the light curtain detection zone and ensure the machinery stops without apparent delay.

Warning The machine shall not start whilst the test piece is blocking the Detection Zone (K) of the light curtain. This is acknowledged by the RED OSSD indicator in the on-state and Green OSSD indicator in the Off-state. The machine shall remain in the stopped condition and/or prevent the machine from restarting. If it does then machine **MUST** be isolated until the reason has been investigated.

For safety light curtain models with an ODC above 40mm undertake the same tests as described. During these tests the output switches should only turn OFF as the test piece totally obscures each beam in the light curtain. Ensure that while the test piece is obscuring each beam the output switches are OFF.

Maintenance

The Transmitter (TX) and Receiver (RX) windows should be cleaned regularly as indicated on the Installation Sheet, Figure K.

Dirt build-up or scratching on the windows may lead to intermittent tripping or a totally blocked condition of the light curtain. Clear adhesive tape may be applied to the windows of curtains in dirty or abrasive conditions. Renew the clear adhesive tape periodically.

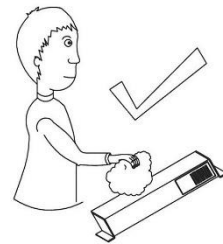

Dust particles can be attracted to the Perspex window due to static charges. This can be prevented by the use of an antistatic plastic cleaner and antistatic cloth.

Clean the windows with a clean damp cloth using a mild detergent. Never use abrasive, corrosive cleaners or spray detergents.



During the maintenance inspection of the safety device and the danger area checks include, damage and general wear, connection cables and the electrical connections, mountings and physical extrusion and Perspex. See also the Operation Cycle checks within this document.

Every 6 months check the entire installation, regular maintenance helps keep the product in good condition and also provides an opportunity to record any modification, manipulation or change to the machine application. This allows for appropriate action including a new risk assessment.

Warning There must not be any means of accessing the danger point without interruption to the infrared field of the safety light curtain.

Figure J – Operation Cycle

- ❑ Before installation read and understand the Installation Sheet provided paying particular attention to the information provided in Fig. E
- ❑ Refer to Fig. K for test and maintenance procedures
- ❑ Every 24 hours carry out tests as indicated in Fig. K
- ❑ Every 6 months check the entire installation paying particular attention to Fig. F
- ❑ If the equipment fails to operate as intended check the electrical connections as shown in Fig. H

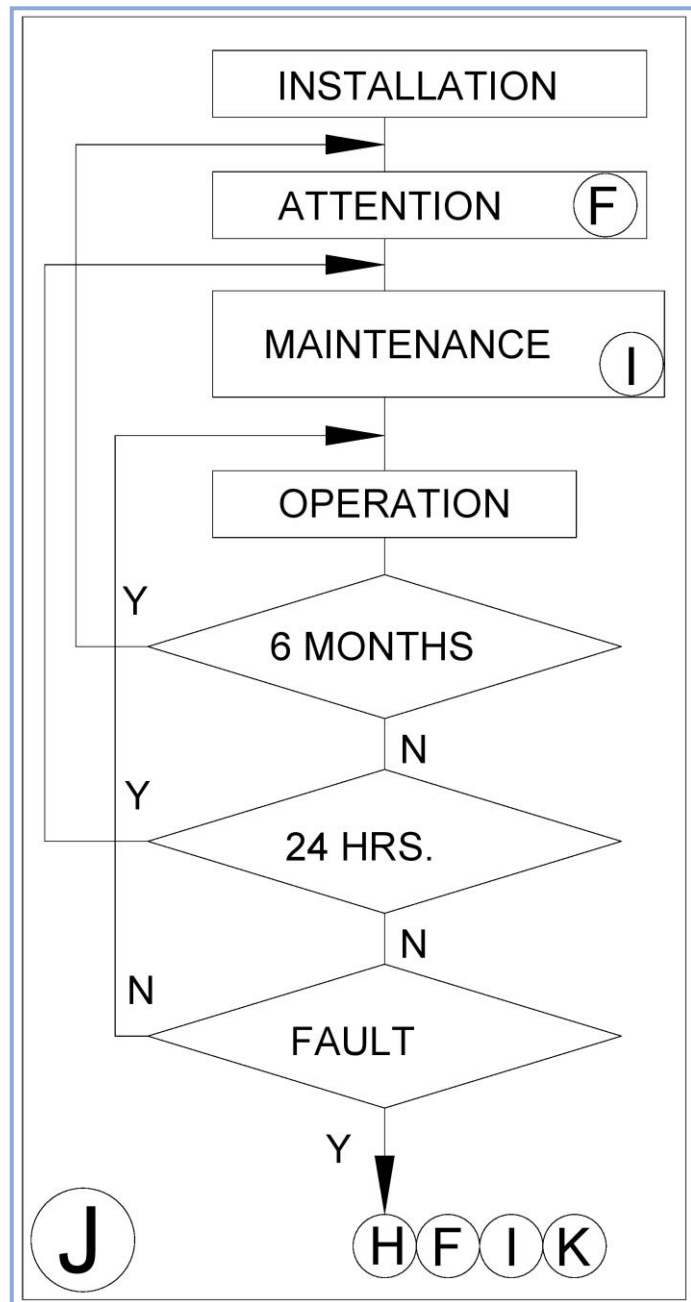
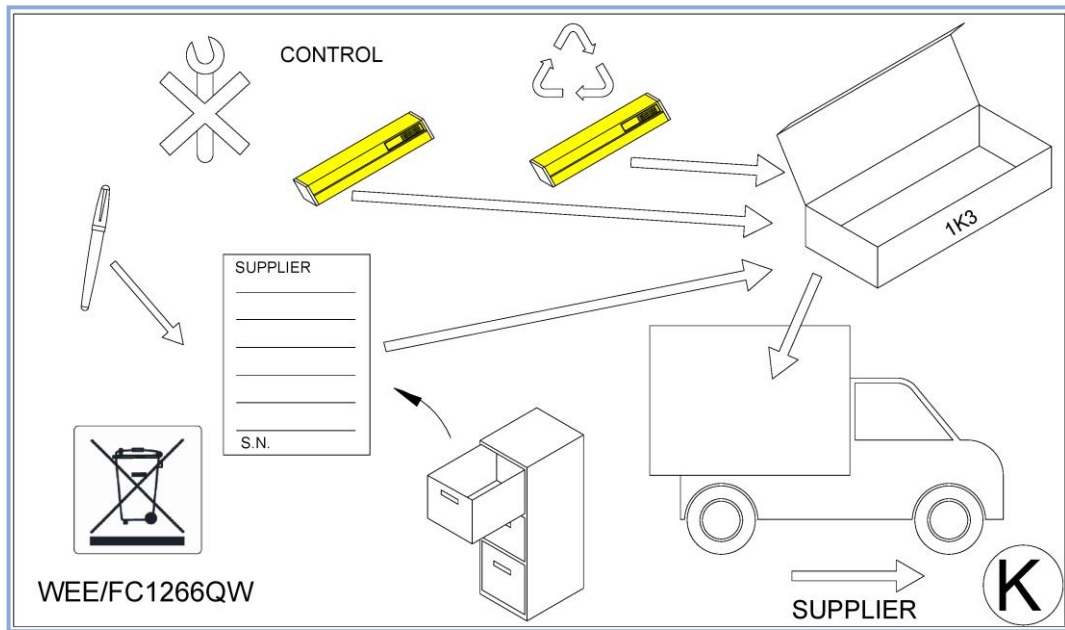

Figure K – Product Return Procedure

If a fault occurs that cannot be resolved or the equipment is damaged return the equipment to the nearest Smartscan distributor or Smartscan Ltd. Indicate the nature of the fault and the symptoms displayed on the Service Questionnaire form provided.

Note Please ensure that returned guards (Transmitter and Receiver heads) are matching serial number pairs.

Disposal of the product should be done in accordance with the regulations of the country where the product is used.

Figure L – Declaration of Conformity



	CD707L/060420
<h3>EC Declaration of Conformity</h3>	
Product:	Smartsan 1K3 Safety Light Curtain series.
Manufacturer:	Smartsan Limited, 1Pywell Road, Willowbrook Industrial Estate, Corby, Northamptonshire, NN17 5XJ, ENGLAND
Declares that the safety component(s) described in serial numbers between 330-000 to 399-999, fulfils the following safety function: Electro-sensitive protective equipment – Active Opto-electronic Protective Device (safety light curtain).	
Conforms to the following Directives:	
Machinery Directive	2006/42/EC
Electromagnetic Conformity Directive	2014/30/EU
Low Voltage Directive	2014/35/EU
Complies with the relevant requirements of the following Standards:	
EN IEC 61496-1, IEC 61496-2	Type 3
EN IEC 62061	SIL 2
EN ISO 13849-1	PL d
EN ISO 13849-1	Category 3
Uses the following standards:	
ISO 12100, EN 60204-1	
Complies with the examples to which the EC type examination certificate below relates, and is in conformity with the protection requirements of Council Directive 2014/30/EU, as amended, on the approximation of the laws of the Member States relating to electromagnetic compatibility.	
The component is of a type listed in Annex IV of the Machinery Directive. Examples have been submitted for type examination by the approved Notified Body as below.	
Safenet Limited	Notified Body Number 1674.
Address	Safenet Limited, Denford Garage, Denford, Kettering, Northamptonshire, NN14 4EQ, U.K.
Certificate No.	TBD
Signed: 	Date: 06/ 04/ 2020
Name: HAROON R KHAWAJA	
Title: Technical Director	
	

Figure M – Glossary of Words and Language Translation

ENGLISH	DANSK	DEUTSCHE	DUTCH	FRANCAIS	ITALIANO	ESPAÑOL	SVENSKA
ATTENTION	attention	achtung	attentie	attention	attenzione	atención	observera
AUTHORISED PERSON	person med autoritet	autorisierte person	bevoegd/ persoon	personne autorisée	personale autorizzato	persona autorizada	behörig person
BEAM CODING	strålekode	Strahlencodierung	strålecodeering	code de faisceau	codifica del raggio	codificación de haz	strålkodning
BEMS	stråle	gitter	stralen	faisceaux	raggi	haces	strålar
BLACK	sort	schwarz	zwart	noir	nero	negro	svart
BLUE	blå	blau	blauw	bleu	blå	azul	blå
BROWN	brun	braun	bruin	marron	marrone	marron	brun
CONTROL	kontrol	auswertegeraet	besturing	contrôle	controllo	controlar	kontroll
DANGER	fare	gefahr	gevaar	danger	pericolo	peligro	fare
DETECTION CAPABILITY	Opiesning	abfragungsfähigkeit	oplossend vermogen	capacité de détection	risoluzione	capacidad de detección	upplösning
DETECTION ZONE	beskyttelses zone	abfragunszone	delecte zone	zone de détection	zona de rilevamento	zona de detección	skyddsstat
DIAGNOSTIC	diagnostisere	diagnostisch	diagnostiek	diagnostique	diagnostico	diagnostico	diagnostisk
DISPOSAL	rådighed	entfernen	weg doen	disposition	smaltimento	disposicion	slangas
FAULT	fej	fehler	fout	défaüt	guasto	incidente	fel
FEATURE	muligheder	eigenschaft	eigenschap	dispositif	caratteristica	característica	egenskaper
FLASHING	blinkende	blitzen, blinken	flitsen	clignotant	lampeggiante	parpadeando	blinkar
GREEN	grøn	grün	groen	vert	verde	verde	grön
INDICATOR	indikation	anzeige	indicator	indicateur	indicatore	indicador	indikering
INSTALLATION	installation	installation	installatie	installation	installazione	instalacion	installation
INSTRUCTIONS	instruktioner	Instruktionen	instructie	instructions	istruzioni	instrucciones	instruktion
LIGHT CURTAIN	lysgitter	lichtgitter	lichtscherm	barrière	barriera ottica	corriña de seguridad	ljus barrier
LOCKOUT	fejlmode	aussperren	system blokkering	bloccage	bloccaggio	cierra	felsäkert läge
MAINTENANCE	vedligeholdelse	wartung	onderhoud	entretien	manutenzione	mantenimiento	underhåll
MAXIMUM	maximum	Maximum	maximum	maximum	massimo	máximo	max
MINIMUM	minimum	minimum	minimum	le minimum	minimo	minimo	minimum
MODEL	model	typ	model	modèle	modello	modelo	modell
MONTHS	månader	monate	maanden	mois	mesi	meses	månader
NOT FLASHING	blinker ikke	NOT blinkt	het opvlammen niet	pas clignotant	non lampeggiante	no parpadea	blinkar inte
OFF	Slukke	aus	uit	off	non attivo	apagado	från
ON	Tænde	ein	aan	on	attivo	en	till
OPERATION	operation	in betrieb	in bedrijf	opération	funzionamento	operacion	drift
OUT	ud	aus	uit	hors / dehors/ extérieur	uscita	fuera	ut
PERIMETER	omkreds	umfang	perimeter	périmètre	perimetro	perimetro	omkrets
RANGE	område	Reichweite	waaler	la gamme	gamma	oscilar	räckvidd
RED	rød	rot	rood	rouge	rosso	rojo	röd
REPAIR	reparere	reparatur	herstellen	réparation	riparazione	reparar	reparation
RESET	Nuistil	zurücksetzen	reset	réinitialiser	Ripristina	Reiniciar	återställa
SAFETY	sikkerhed	sicherheit	veiligheid	sécurité	sicurezza	seguridad	säkerhet
STATUS	status	status	status	statut	stato	estado	status
STEADY	rolig	zuverlässig	geïjkmattig	fixe	stabile	constante	stabil
SUPPLIER	leverandør	lieferant	leverancier	fournisseur	fornitore	proveedor	leverantör
SYSTEM	system	system	system	systeme	sistema	sistema	systemet
TEST PIECE	prøvestykke	Teststück	test stuk	pièce d'essai	pezzo di prova	pieza de prueba	testbit
UNEVEN FLASHING	ujævnt blinkende	ungleichmäßiges Blinken	het ongelijke opvlammen	clignotement inégal	lampeggiamento irregolare	parpadeo desigual	ojläm blinkande
WHITE	hvid	weiss	wit	blanc	bianco	bianco	vit
YEAR	år	Jahr	jaar	année	anno	afío	år
YELLOW	gul	gelb	geel	jaune	giallo	amarillo	gul



Appendix 1 – Important Safety Information

- ❑ Ensure that the Smartsan safety light curtain is installed by a competent person using the installation information provided.
- ❑ Smartsan safety light curtains are supplied as matching serial number pairs and must be used as matching serial number pairs.
- ❑ It is the responsibility of the employer that the safety light curtain is properly installed, operated and maintained as well as the suitable machinery on which the safety product is installed. All the applicable national and international legislation and technical standards for the corresponding machine application must be complied with.
- ❑ The safety light curtain is only one element in the overall machine safety circuit, the whole machine safety control circuit must be a fail-safe design.
- ❑ Do not operate the machine/safety circuit until 2 seconds or more after power-up. The machine must be stopped by electrical control when using a safety light curtain.
- ❑ The stopping elements of the machine should be regularly checked to make sure the machine stop time performance is reliable and within the specified parameters. It must be possible to achieve a safe stop from any point in the dangerous part of the machine cycle.
- ❑ Do not repair, disassemble or modify the Smartsan safety light curtain. Smartsan products can only be repaired by the manufacturer. Any work carried out on the product that is not done by the manufacturer will invalidate the warranty terms. All products being returned for repair must be matching serial number pairs.
- ❑ The Smartsan Product installation sheet and installation guide do not provide instruction or operation information for the machine that it is integrated to.
- ❑ The Smartsan Product Installation instructions should be kept with the safety light curtain during its entire working life.

Appendix 2 - Certifications

Company



ISO9001
FM27829

Smartsan Limited has a certified quality assurance system in compliance with ISO 9001-2015. Certificate number FM27829.

Products



Smartsan safety light curtains are developed and manufactured in compliance with the European Machinery Directive 2006/42/EC and International Legislation and Standards. Smartsan products are Third Party approved by the Notified Body Safenet Limited, Notified Body number 1674.

Appendix 3 - Mirrors

Reflector mirrors can be provided enabling two or three sides of a machine to be safeguarded with, what is effectively a single light curtain.

When mirrors are employed it is essential that the mounting of the transmitter unit, receiver unit and mirrors themselves are sufficiently rigid. Alignment becomes increasingly critical as the range and number of mirrors increase. Mirrors cause a reduction in optical efficiency, reducing the effective range. A guide to the practicality of using mirrors is given below.

Range of the light curtain	Maximum range through 1 mirror	Maximum range through 2 mirrors
4m - 10m	8m	6.5m

Total Light Path	1 Mirror	2 Mirror
2m	Easy	Easy
4m	Easy	Medium
6m	Medium	Hard
8m	Hard	Not Feasible

Based upon a 1K3-105

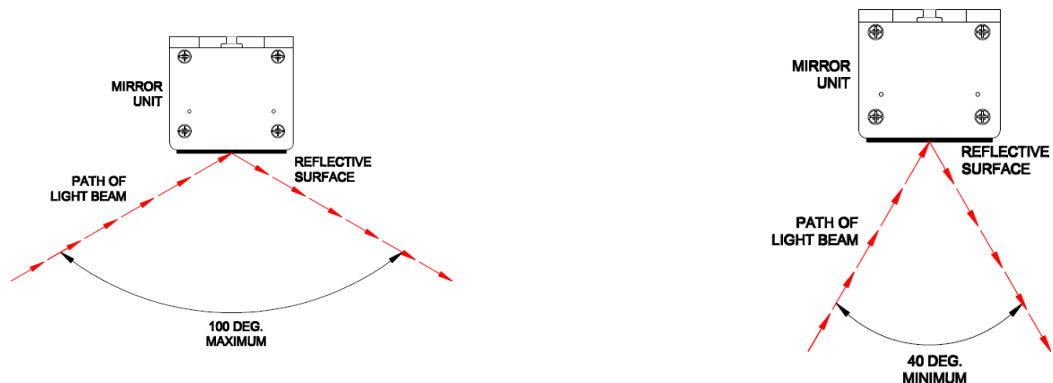

The angle of the infrared beams from the safety light curtain striking the reflective surface must be within defined limits as per the drawings above. See Fig. F in this guide.

Note: The mirror length must be a minimum of 100mm longer than the overall length of the light curtain to be installed e.g. 50mm above and 50mm below either end of the light curtain.

Perimeter curtains will be easier to align, curtains over 900mm may be more difficult to align. Check with the Smartsan technical department prior to ordering for a particular application, support@smartsan.com, Tel: +44 (0) 1536 401 313

Alignment through one mirror

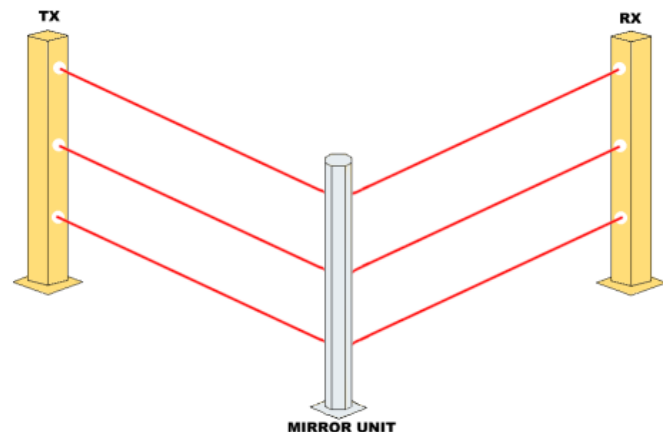

1. Secure the transmitter, receiver and mirror units in the position in which they are intended to be used.
2. Ensure all units are perfectly upright in all planes by using a spirit level.
3. If the units are floor mounted on stands ensure the floor is even. Shim the floor mounts if necessary, to ensure the units are all upright.
4. With one eye looking over the top of the receiver unit in line with the centre of the extrusion look towards the reflective surface of the mirror, in a similar manner to looking through a gun sight.
5. A second person must adjust the mirror to the left and right until the Perspex window of the transmitter unit can be seen reflected in the mirror.
6. If the light curtain is scanning over a long range it may be difficult to see the reflection of the transmitter units Perspex window in the mirror. If so, cut a piece of white paper to the size of the Perspex window and mount directly in front of the window. Now repeat step 5.
7. If the reflection of the white paper is difficult to see in the mirror then employ a third person to hold a flashlight in front of the transmitter unit with the light beam pointing directly in line with the Perspex window towards the mirror. Now repeat step 5.
8. Use shims to ensure the mirror is accurately aligned to enable the infrared beams in the light curtain to reach the receiver. Alternatively, fabricate mirror mountings to include some form of adjustment to enable movement both left and right and also forward and backwards from the central axis of the mirror.

Alignment through two mirrors

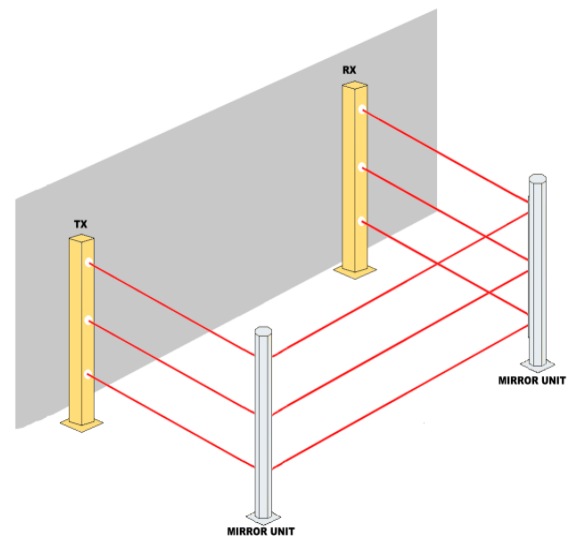

9. Follow instruction 1-4
10. A second person must adjust the position of the first mirror to the left and to the right until the entire length of the second mirror is reflected in the first mirror. If difficulties are experienced in seeing the reflection on the second mirror in the first mirror then use a piece of white paper cut to size and position in front of the second mirror.
11. If the reflection of the white paper is difficult to see in the first mirror then employ a third person to hold a flashlight in front of the second mirror with the light beam pointing directly in line with its mirror housing towards the first mirror. Secure the first mirror.
12. Again, follow instructions 1 to 4.
13. The second person must adjust the position of the second mirror to the left and to the right until the entire length of the transmitter unit is reflected through both the first mirror and the second mirror. If difficulties are experienced in seeing the reflection of the transmitter unit through both the first then the second mirrors then use a piece of white paper cut to size and position in front of the transmitter unit.
14. If the reflection of the white paper is still difficult to see through the first and second mirrors then employ a third person to hold a flashlight in front of the transmitter unit with the light beam pointing directly towards the second mirror. Secure the second mirror.
15. Ensure the mirrors are directly aligned thus enabling the infrared beams of the transmitter to reach the receiver. Alternatively, fabricate mirror mountings to include some form of adjustment to enable movement both left and right and also forwards and backwards from the central axis of each mirror.

- Now turn on the power to the light curtain and check that the green LED beam indicator, mounted on the receiver unit is 'on'. If not, it may be necessary to finely adjust each mirror in turn to ensure the infrared energy from the transmitter unit is being reflected through the mirror(s) to the corresponding receiver unit.

Alignment of the light curtain using mirrors

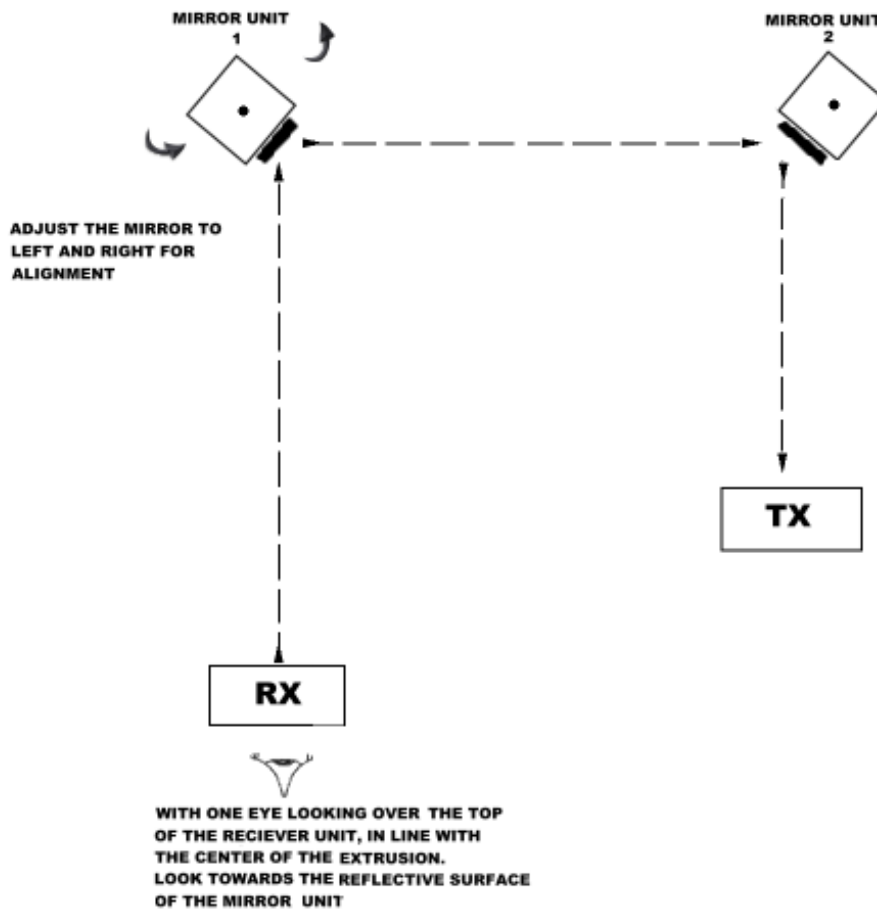

Note: The mirror length must be a minimum of 100mm longer than the overall length of the light curtain to be installed e.g. 50mm above and 50mm below either end of the light curtain.

Appendix 4 – Specification Table

Specification	1K3 series
Number of beams	2 – 96
Object detection	30mm, 40mm and Perimeter guarding systems
Detection zone	180mm to 1840mm
Range	30mm ODC 0.5 – 5m 40mm ODC 4 – 10m Perimeter/ Body 0.5 – 5m and 4 – 10m
Light type	Infrared 880nm
Response time	20ms
Operating temperature	-10°C to +50°C
Light curtain enclosure	IP65, (H x W x D) H x 28 x 41mm
Status indicators	<u>Receiver head (Rx)</u> Red (steady) OSSDs 'OFF'. Red (flashing) system lockout. Green OSSDs 'ON'. Green (flashing) output fault. Yellow (flashing) Tx to Rx communications established. Yellow (steady) incorrectly aligned or detection zone is 'blocked'. <u>Transmitter head (Tx)</u> Yellow (flashing) Tx 'Ok'.
Power supply requirements	24V DC \pm 10%, 1.5A regulated
Current consumption	200mA transmitter and 200mA receiver + (OSSD current consumption)
Light curtain connection	5m cables connected to both Tx and Rx heads
Finish	Aluminium, Polyester powder coated (yellow)
Safety Classification	BS EN 61496-1 Type 3 BS IEC 61496-2 Type 3 EN ISO 13849 PL d EN 62061 - SIL 2

Outputs	
Safety Outputs OSSD1 & OSSD2	2 x electronic switches, each rated at 24V DC, Maximum 500mA – ON = 24V DC, OFF = 0V (Minimum 20mA)

