

Classification	REFERENCE SPECIFICATION	Issue No. 20151589
Part Name 3.5mm x 2.9mm Side-Operational SMD Light Touch Switch	Part No. EVQP7D01P	1 / 8
<p>1. Notification Items</p> <p>1.1 Law and the regulation which are applied</p> <ul style="list-style-type: none"> ① Ozone depleting substances specified by Montreal Protocol have not been used in the manufacturing process of the material used in this product. ② This product complies with RoHS Directive (on the restriction of the use of certain hazardous substances in electrical and electronic equipment) (2011/65/EU). ③ The materials used in this product contain only the substances listed in the List of Existing Chemical Substances specified in 'Act on the Evaluation of Chemical Substances and Regulation of Their Manufacture, etc'. ④ Permission must be obtained from the Japanese government if the product that is subject to the "Foreign Exchange and Foreign Trade Law" is to be exported or taken out of Japan. <p>1.2 Application Limits</p> <p>The following shall be described for safety precaution: [Limitation of Application]</p> <ul style="list-style-type: none"> (a) This product has been designed and manufactured for general electronic devices, such as home electronics, office equipment, information devices and communication devices. <ul style="list-style-type: none"> (1) This product is not intended for use in more sophisticated applications which require a higher safety standard and more reliability, including if a failure or malfunction may cause bodily injury or property damage. (2) If the product is intended for more sophisticated applications prior approval must be obtained. Such applications shall include, but are not limited to, the following: aircraft equipment, aerospace equipment, disaster prevention equipment, crime prevention equipment, medical equipment, transportation equipment (such as vehicles, trains, ships, etc.), and information processing equipment that are highly publicized, and other equivalent equipment. (b) Regardless of its applications, in an event that this product is used for equipment with high safety standards, protective circuits or back up circuits must be used and safety tests must be performed. <p>1.3 Handling of reference specification.</p> <ul style="list-style-type: none"> • Since the contents of this reference specification are subjected to change without prior notifications, please request us a formal specification again for your investigations before using. <p>1.4 Manufacturing Sites</p> <p>The country of manufacture : Malaysia Panasonic Industrial Devices Malaysia Sdn. Bhd. The country of manufacture : China Panasonic Industrial Devices (Qingdao) Co., Ltd.</p> <p>2. Summary</p> <p>2.1 This specifications applies to the following types of switch. Push-ON type S.P.S.T</p> <p>2.2 This specifications is a constituent document of contract for business concluded between your company and Panasonic Corporation.</p> <p>2.3 Items not particularly specified in this specifications shall be in conformance with JIS Standards.</p>		

Classification	REFERENCE SPECIFICATION	Issue No. 20151589
Part Name 3.5mm x 2.9mm Side-Operational SMD Light Touch Switch	Part No. EVQP7D01P	2 / 8

3. Dimension•Marking•Circuit diagram

REFERENCE ONLY

Date code are indicated in the product.
 General dimension tolerance : ± 0.2
 () dimensions are reference dimensions.

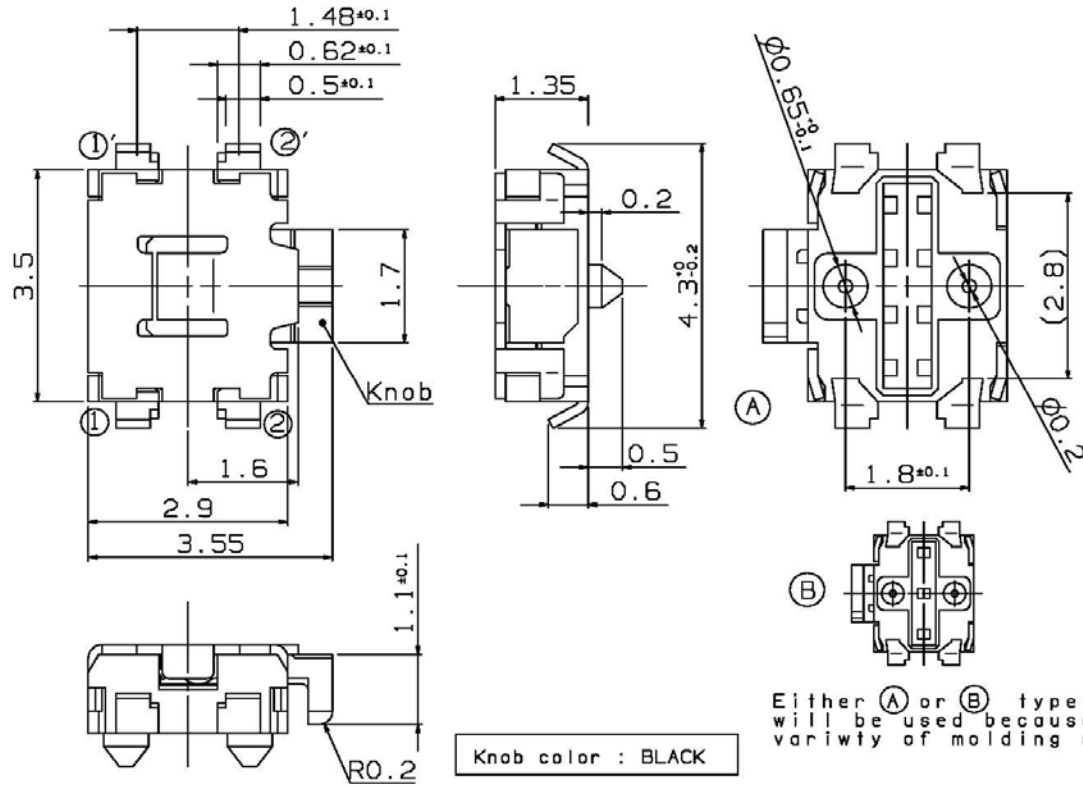

Knob color : BLACK

Piece weight : about 0.035g

Solder thickness $t=0.15\pm 0.03$

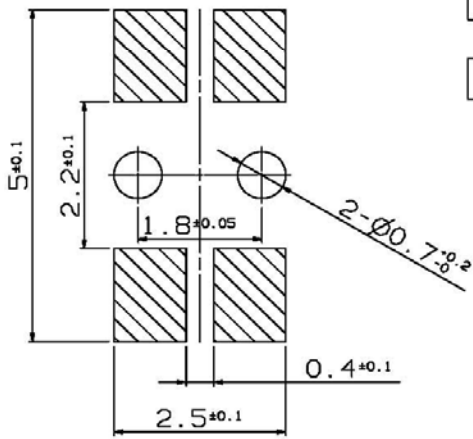

Land pattern plan

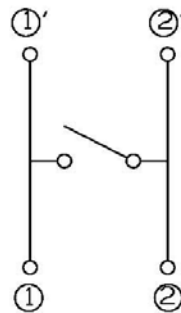

Circuit Diagram

Please connect ② and ②' to the Ground terminal for ESD.

Classification	REFERENCE SPECIFICATION	Issue No. 20151589
Part Name 3.5mm x 2.9mm Side-Operational SMD Light Touch Switch	Part No. EVQP7D01P	3 / 8

4. General specification

4.1 Switch rating DC 12 V 50 mA(max.) DC 2 V 10 µA(min.)

4.2 Operation temperature range -20 ~ + 70 °C

4.3 Preservative temperature range Single condition : - 40 ~ + 85 °C
 Taping conditior : - 20 ~ + 60 °C

4.4 Standard conditions

Unless otherwise specified, the test and measurements shall be carried out as follows.

 Ambient temperature : 5 ~ 35 °C

 Relative humidity : 45 ~ 85 %

 Atmospheric pressure : 86 ~ 106 kPa

However, if doubt arises on the decision based on the measured values under the above-mentioned conditions, the following conditions shall be employed.

 Ambient temperature : 20 ± 2 °C

 Relative humidity : 65 ± 5 %

 Atmospheric pressure : 86 ~ 106 kPa

5. Performance

5.1 Electrical characteristics

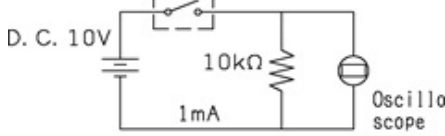
No.	ITEM	TEST CONDITION	PERFORMANCE
5.1.1	Contact resistance	Push force : {Operation force} × 2 Measurement tool : Contact resistance meter (Capable of 10 µA ~ 10 mA)	500 mΩ max.
5.1.2	Insulation resistance	DC 100 V (Between terminals)	100 MΩ min.
5.1.3	Withstand voltage	AC 250 V for 1 minute. (Between terminals)	No insulation destruction
5.1.4	Bouncing	Operation speed : 3~4 times/s  <u>Switch Bouncing Test Circuit</u>	ON 10 ms max. OFF 10 ms max.

5.2 Mechanical characteristics

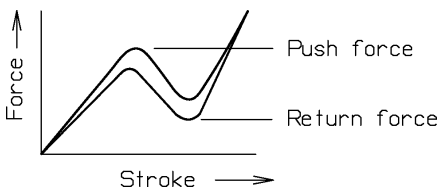
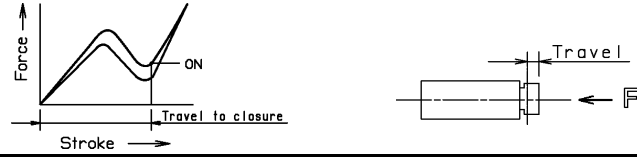
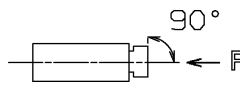
No.	ITEM	TEST CONDITION	PERFORMANCE
5.2.1	Operation force		Push force $2.2 \begin{matrix} + \\ - \end{matrix} \begin{matrix} 0.8 \\ 0.7 \end{matrix} \text{ N}$ Return force 0.2 N min
5.2.2	Travel to closure		$0.2 \begin{matrix} + \\ - \end{matrix} \begin{matrix} 0.2 \\ 0.1 \end{matrix} \text{ mm}$
5.2.3	Push strength	30 N for 1 minute. 	No damage (Electrical and mechanical)
5.2.4	Vibration test	1) Amplitude : 1.5 mm 2) Sweep rate : 10-55-10Hz for 1 minute 3) Sweep method : Logarithmic frequency sweep rate 4) Vibration direction : X,Y,Z(3 directions) 5) Time : Each direction 2 hours (Total 6 hours)	No.5.1 and 5.2.1 to 5.2.2 shall be satisfied.
5.2.5	Soldering heat test	Mount the switch on P.W.B by solder paste. 1) Reflow process 2 times. (Refer to section 6.1) 2) Standard conditions after test : 1 hours	Contact resistance 500 mΩ max. No.5.1.2 to 5.1.4 and No.5.2.1 to 5.2.2 shall be satisfied.
5.2.6	Solderability	After spreading flux, the terminal is immersed in solder with following condition. Solder bar : M705/Sn-3.0Ag-0.5Cu (Senju Metal Industry Co.,Ltd.) Flux : CF-110VH-2A (tamura kaken) Soldering temperture : 260±5 °C Soldering time : 2±0.5 sec.	95% or more of surface area(Excluding ruptured surface)where is immersed in solder shall be covered by new solder.

Classification	REFERENCE SPECIFICATION	Issue No. 20151589
Part Name 3.5mm x 2.9mm Side-Operational SMD Light Touch Switch	Part No. EVQP7D01P	5 / 8

5.3 Climatic characteristics

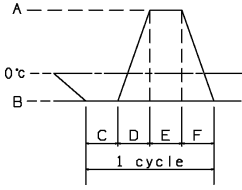
No.	ITEM	TEST CONDITION	PERFORMANCE
5.3.1	Cold test	1) Temperature : $-40\pm 2\text{ }^{\circ}\text{C}$ 2) Duration of test : 500h 3) Take off a drop water. 4) Standard conditions after test : 1 h	Contact resistance 500 mΩ max. No.5.1.2 to 5.1.4 and No.5.2.1 to 5.2.2 shall be satisfied.
5.3.2	Heat test	1) Temperature : $85\pm 2\text{ }^{\circ}\text{C}$ 2) Duration of test : 500h 3) Standard conditions after test : 1 h	Contact resistance 500 mΩ max. No.5.1.2 to 5.1.4 and No.5.2.1 to 5.2.2 shall be satisfied.
5.3.3	Heat shock test	1) Test cycles : 20 cycles 2) Standard conditions after test : 1 h  A: $+85\pm 2\text{ }^{\circ}\text{C}$ B: $-40\pm 2\text{ }^{\circ}\text{C}$ C: 1 hour D: 5 minutes max. E: 1 hour F: 5 minutes max.	Contact resistance 500 mΩ max. No.5.1.2 to 5.1.4 and No.5.2.1 to 5.2.2 shall be satisfied.
5.3.4	Humidity test	1) Temperature : $60\pm 2\text{ }^{\circ}\text{C}$ 2) Relative humidity : 90~95 % 3) Duration of test : 500 h 4) Take off a drop water. 5) Standard conditions after test : 1 h	Contact resistance 500 mΩ max. No.5.1.2 to 5.1.4 and No.5.2.1 to 5.2.2 shall be satisfied.
5.3.5	Endurance (Switching action)	1) DC 12 V 50 mA Resistance load 2) Operation speed : 2~3 times/s 3) Push force : Maximum value of operation force 4) Operation number : 100,000 times	Contact resistance 1000m Ω max. Bouncing : 20 ms max. Variation rate of operation force shall be within $\pm 30\%$ to the value before testing No.5.1.2 and 5.2.2 shall be satisfied.
5.3.6	Withstand H ₂ S	1) Density : 3±1ppm 2) Temperature : $40\pm 2\text{ }^{\circ}\text{C}$ 3) Relative humidity : 80~85 % 4) Duration of test : 24 h 5) Standard conditions after test : 1 h	Contact resistance 500 mΩ max. No.5.1.2 to 5.1.4 and No.5.2.1 to 5.2.2 shall be satisfied.

Classification	REFERENCE SPECIFICATION	Issue No. 20151589
Part Name 3.5mm x 2.9mm Side-Operational SMD Light Touch Switch	Part No. EVQP7D01P	6 / 8

6. Prohibitions and precaution for handling

6.1 Reflow soldering condition

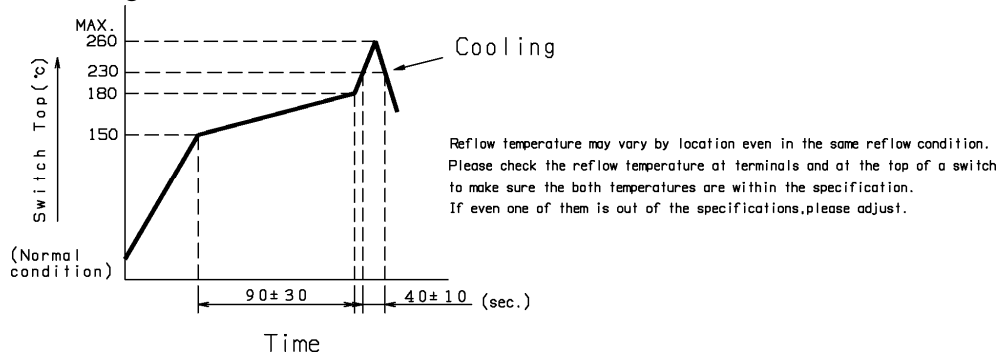

- 1) Two times max. with directing the switch mounting side of P.W.B up.
- 2) Re-soldering by soldering iron shall be allowed under 350 °C max. 3 sec. max. 1 time only and the tip of iron must not touch to terminals.
Soldering iron for re-soldering have to be 60 W max.

6.2 Design instructions

- 1) Please refer to the land pattern plan Panasonic recommends on the 2nd page.
- 2) Design key top as fig-1. Design inclination of key top 5 deg. max. as fig-2 and fig-3.
In order to protect the switch from direct impact, install the stopper as fig-4.
Deviation between center of key top and switch should be within 0.3 mm. as fig-5.
(Recommended operation condition)

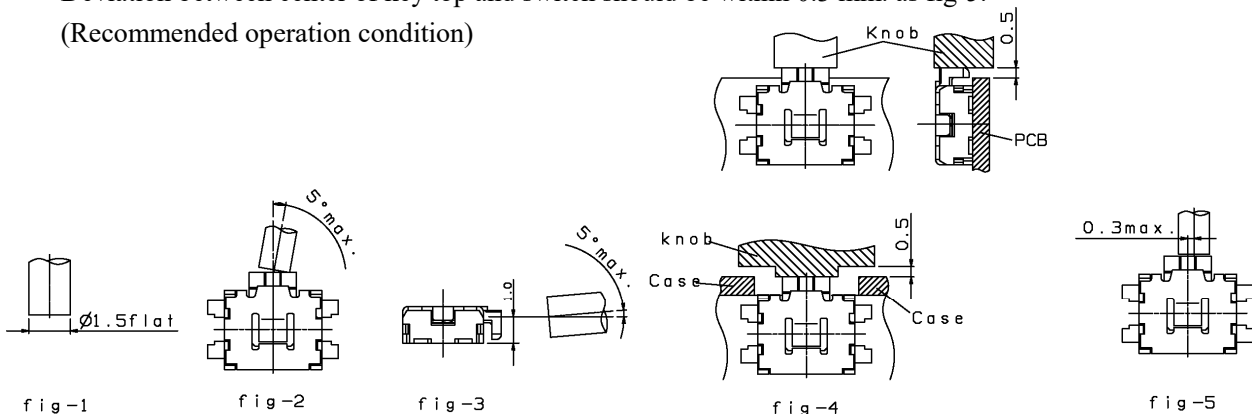

6.3 Note

- 1) Please use caution not to give excessive static load or shock.
Do not apply load to the switch except to the operation part in the operation direction.
- 2) Don't solder a flow method behind the switch mount.
- 3) Preservation under high temperature and high humidity or corrosive gas should be avoided especially.
When you need to preserve for a long period, do not open the carton.
- 4) Avoid the use of the switch under pushed ON condition is continued for a long time.
- 5) Please do not wash or clean the switch with water or an organic solvent.
- 6) There is a possibility the flux from solder paste infiltrates into the body if plenty of solder paste was applied by switch on the P.W.B.
So we recommend to use our proposed land design in order to prevent above problem.
Also please avoid putting additional land by the switch on the P.W.B.

Classification	REFERENCE SPECIFICATION	Issue No. 20151589
Part Name 3.5mm x 2.9mm Side-Operational SMD Light Touch Switch	Part No. EVQP7D01P	7 / 8

7. Packing specification

Carrier tape

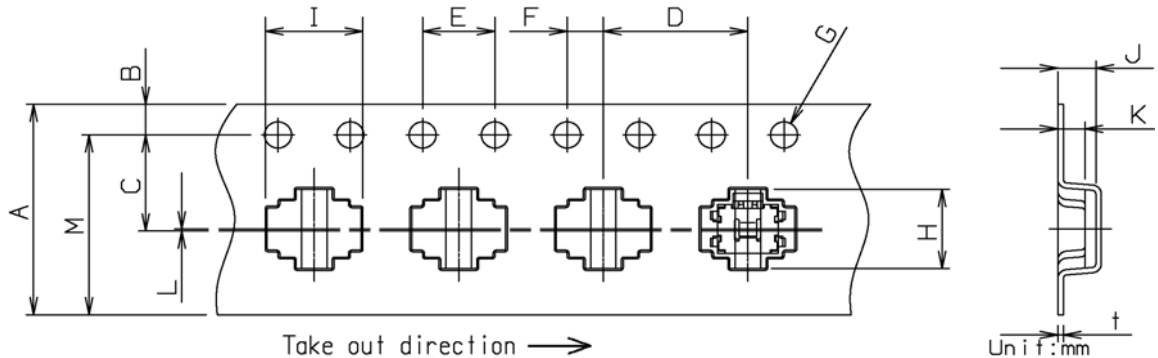

A	B	C	D	E	F	G	H	I	J	t	K	L	M
±0.3	±0.1	±0.1	±0.1	±0.1	±0.1	±0.1	±0.2	±0.2	±0.2	±0.1	±0.2	±0.1	(10.25)
12	1.75	5.5	8	4	2	1.5	4.5	4.5	2.1	0.3	1.5	0.12	

- * Taping condition : Lack of products in the middle of taping should be one MAX.
but total quantity specified in the specifications should be secured.
- * Peeling off strength of top tape : It should be within 0.2N to 1.0N at 165 degree in peeling off angle.
- * Joint of carrier tape : One joint per one reel may exist.

Reel(5000 pcs./reel)

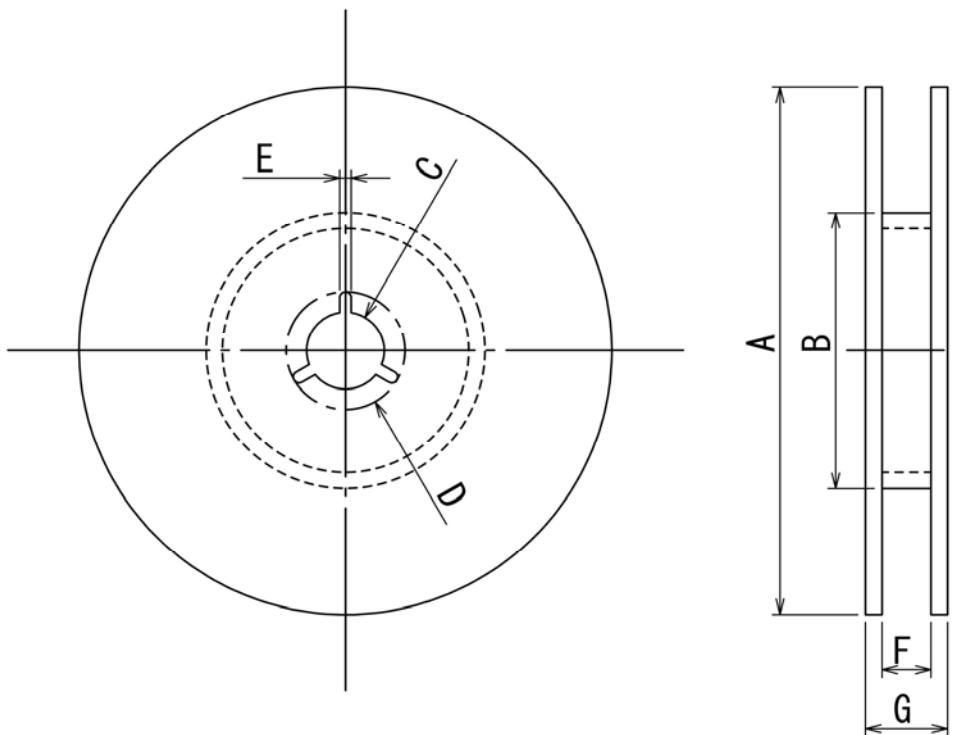

A	B	C	D	E	F	G
±2	±1	±0.2	±0.8	±0.5	±1	±1
Φ380	Φ80	Φ13	Φ21	2	13.4	17.4

Unit:mm

Classification	REFERENCE SPECIFICATION	Issue No. 20151589
Part Name 3.5mm x 2.9mm Side-Operational SMD Light Touch Switch	Part No. EVQP7D01P	8 / 8
<p><Prohibitions and precaution for handling></p> <p>【Prohibited items on fire and smoking】</p> <ul style="list-style-type: none"> • Absolutely avoid use of a product beyond its rated range because doing so may cause a fire. If misuse or abnormal use may result under conditions in which the product is used out of its rated range, take proper measures such as current interruption using a protective circuit. • The grade of nonflammability for resin used in product is "94HB, " which is based on UL94 Standards (flammability test for plastic materials). Prohibit use in a location where a spreading fire may be generated or prepare against a spreading fire. <p>【For use in equipment for which safety is requested】</p> <ul style="list-style-type: none"> • Although care is taken to ensure product quality, inferior characteristics, short circuits, and open circuits are some problems that might be generated. To design an equipment which places maximum emphasis on safety, review the effect of any single fault of a product in advance and perform virtually fail-safe design to ensure maximum safety by: <ul style="list-style-type: none"> • Preparing a protective circuit or a protective device to improve system safety, and equipment. • Preparing a redundant circuit to improve system safety so that the single fault of a product does not cause a dangerous situation. <p>【Attentions required for storage condition】</p> <ul style="list-style-type: none"> • When this product is to be stored in the following circumstances and conditions, it may affect on the performance deteriorations and solderability etc., avoid storing in the following conditions. <ol style="list-style-type: none"> (1) A place where the temperature is -10°C max., +40°C min. and the humidity is 85% min. (2) In the corrosive gas atmosphere. (3) Long-term storage for 6 months min. (4) A place where the product is exposed to direct sunlight. • Store in packed condition so that the load stress is not applied. • Please use this product as soon as possible, our recommendation is within 3 months and the limitation is 6 months. • If any remainder left after packing is opened, store it with proper moistureproofing and gasproofing, etc., 		