

DRV8801-Q1 DMOS Full-Bridge Motor Drivers

1 Features

- Qualified for Automotive Applications
- AEC-Q100 Qualified With The Following Results:
 - Device Temperature Grade 1: $T_A = -40^{\circ}\text{C}$ to 125°C
 - Device HBM ESD Classification Level H2
 - Device CDM ESD Classification Level C4
- Low $R_{DS(on)}$ Outputs (0.83- Ω HS + LS Typical)
- Low-Power Sleep Mode
- 100% PWM Supported
- 8–38 V Operating Supply Voltage Range
- Thermally Enhanced Surface Mount Package
- Configurable Overcurrent Limit
- **Protection Features**
 - VBB Undervoltage Lockout (UVLO)
 - Overcurrent Protection (OCP)
 - Short-to-supply Protection
 - Short-to-ground Protection
 - Overtemperature Warning (OTW)
 - Overtemperature Shutdown (OTS)
 - Overcurrent and Overtemperature Fault Conditions Indicated on Pins (nFAULT)

2 Applications

- Automotive Body Systems
- Door Locks
- HVAC Actuators
- Piezo Alarm

3 Description

The DRV8801-Q1 provides a versatile power driver solution with a full H-bridge driver. The device can drive a brushed DC motor or one winding of a stepper motor, as well as other devices like solenoids. A simple PHASE/ENABLE interface allows easy interfacing to controller circuits.

The output stages use N-channel power MOSFETs configured as $\frac{1}{2}$ -H-bridges. The DRV8801-Q1 is capable of peak output currents up to ± 2.8 A and operating voltages up to 38 V. An internal charge pump generates needed gate drive voltages.

A low-power sleep mode is provided which shuts down internal circuitry to achieve very low quiescent current draw. This sleep mode can be set using a dedicated nSLEEP pin.

Internal protection functions are provided: undervoltage lockout, overcurrent protection, short-to-supply protection, short-to-ground protection, overtemperature warning, and overtemperature shutdown. Overcurrent (including short-to-ground and short-to-supply) and overtemperature fault conditions are indicated via an nFAULT pin.

The DRV8801-Q1 is packaged in a 16-pin QFN package with exposed thermal pad, providing enhanced thermal dissipation.

Device Information⁽¹⁾

PART NUMBER	PACKAGE	BODY SIZE (NOM)
DRV8801-Q1	QFN (16)	4.00 mm x 4.00 mm

(1) For all available packages, see the orderable addendum at the end of the datasheet.

Simplified Schematic

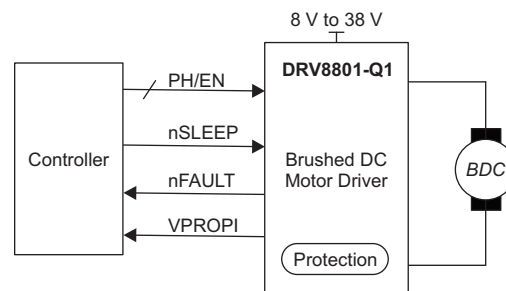

Table of Contents

1 Features	1	7.4 Device Functional Modes.....	14
2 Applications	1	8 Application and Implementation	15
3 Description	1	8.1 Application Information.....	15
4 Revision History	2	8.2 Typical Application	15
5 Pin Configuration and Functions	4	9 Power Supply Recommendations	18
6 Specifications	5	9.1 Bulk Capacitance	18
6.1 Absolute Maximum Ratings	5	10 Layout	19
6.2 ESD Ratings.....	5	10.1 Layout Guidelines	19
6.3 Recommended Operating Conditions.....	5	10.2 Layout Example	19
6.4 Thermal Information	5	11 Device and Documentation Support	20
6.5 Electrical Characteristics.....	6	11.1 Documentation Support	20
6.6 Timing Requirements	7	11.2 Receiving Notification of Documentation Updates	20
6.7 Typical Characteristics	9	11.3 Community Resources.....	20
7 Detailed Description	10	11.4 Trademarks	20
7.1 Overview	10	11.5 Electrostatic Discharge Caution.....	20
7.2 Functional Block Diagram	10	11.6 Glossary	20
7.3 Feature Description.....	10	12 Mechanical, Packaging, and Orderable Information	20

4 Revision History

NOTE: Page numbers for previous revisions may differ from page numbers in the current version.

Changes from Revision B (January 2016) to Revision C	Page
• Changed one of the MODE1 pins to MODE2 in the <i>Functional Block Diagram</i> section	10
• Added the <i>Receiving Notification of Documentation Updates</i> section	20

Changes from Revision A (January 2014) to Revision B	Page
• Added <i>ESD Rating</i> table, <i>Feature Description</i> section, <i>Device Functional Modes</i> , <i>Application and Implementation</i> section, <i>Power Supply Recommendations</i> section, <i>Layout</i> section, <i>Device and Documentation Support</i> section, and <i>Mechanical, Packaging, and Orderable Information</i> section	5
• Added t_{pd} to the <i>Overcurrent Control Timing</i> image	13

Changes from Original (February 2011) to Revision A	Page
• Deleted part number DRV8800-Q! from page header.....	1
• Added AEC-Q100 qualifications to Features list	1
• Added an Applications section to the front page.....	1
• Deleted Ordering Information table	1
• Deleted DRV8800-Q! pinout diagram.....	4
• Deleted Terminal Name column for DRV8800-Q1 from Terminal Functions table	4
• Deleted DRV8800-Q1 pin descriptions for pins 5 and 9 from Terminal Functions table.....	4
• Added a Thermal Information table	5
• Removed DRV8800-Q1 part number from column heading of Thermal Information table	5
• Changed parameter name and test condition for Electrical Characteristics, VTRP row	6
• Added two notes to end of Electrical Characteristics table	6
• Changed "Overcurrent protection period" parameter to "Overcurrent retry time"	7
• Deleted DRV8800-Q1 from text of Device Operation section	10
• Deleted DRV8800-Q1 Functional Block Diagram.....	10

• Updated the <i>Overcurrent Control Timing</i> image.....	13
• Changed <i>active low</i> to <i>low</i> in Diagnostic Output section.....	14
• Deleted VREG section; deleted "(DRV8801-Q1 Only)" from VPROPI section title.....	14
• Changed a value in row 5 of the Control Logic Table	14
• Added a row to Control Logic Table	14
• Deleted DRV8800-Q1 from the text of the Low-Power Mode section.....	14
• Deleted DRV8800-Q1 Typical Application Diagram	15
• Corrected part number in DRV8801-Q1 application diagram.....	15

5 Pin Configuration and Functions

**RTY Package
16-Pin QFN With Exposed Thermal Pad
Top View**

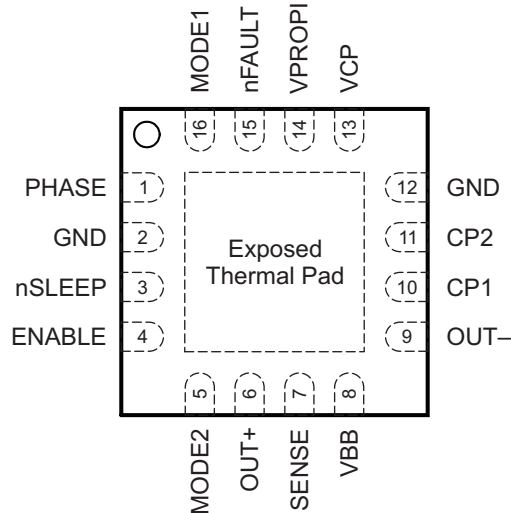

Pin Functions

PIN		I/O	DESCRIPTION
NAME	NO.		
CP1	10	PWR	Charge-pump capacitor 1
CP2	11	PWR	Charge-pump capacitor 2
ENABLE	4	I	Enable logic input
GND	2, 12	PWR	Ground
MODE 1	16	I	Mode logic input
MODE 2	5	I	Mode 2 logic input
nFAULT	15	O	Fault open-drain output
nSLEEP	3	I	Sleep logic input
OUT+	6	O	DMOS full-bridge output positive
OUT-	9	O	DMOS full-bridge output negative
PHASE	1	I	Phase logic input for direction control
SENSE	7	I	Sense power return
VBB	8	PWR	Load supply voltage
VCP	13	O	Reservoir capacitor
VPROPI	14	O	Winding current proportional voltage output
Thermal Pad	PAD	PWR	Exposed pad for thermal dissipation; connect to GND pins.

6 Specifications

6.1 Absolute Maximum Ratings

over operating free-air temperature range (unless otherwise noted) ⁽¹⁾

		MIN	MAX	UNIT
V _{BB}	Load supply voltage ⁽²⁾	-0.3	40	V
I _{OUT}	Output current	0	2.8	A
V _{Sense}	Sense voltage	-500	500	mV
V _{BB_OUT}	V _{BB} to OUTx		36	V
V _{OUT_SEN}	OUTx to SENSE		36	V
V _{DD}	Logic input voltage ⁽²⁾	-0.3	7	V
P _D	Continuous total power dissipation	See Thermal Information		
T _A	Operating free-air temperature	-40	125	°C
T _J	Maximum junction temperature	-40	150	°C
T _{stg}	Storage temperature	-40	125	°C

- (1) Stresses beyond those listed under *Absolute Maximum Ratings* may cause permanent damage to the device. These are stress ratings only, which do not imply functional operation of the device at these or any other conditions beyond those indicated under [Recommended Operating Conditions](#). Exposure to absolute-maximum-rated conditions for extended periods may affect device reliability.
- (2) All voltage values are with respect to network ground terminal.

6.2 ESD Ratings

		VALUE	UNIT	
V _(ESD)	Electrostatic discharge	Human body model (HBM), per AEC Q100-002 ⁽¹⁾	±2000	
		Charged device model (CDM), per AEC Q100-011	Corner pins (1, 4, 5, 8, 9, 12, 13, and 16)	±750
			Other pins	±500

- (1) AEC Q100-002 indicates HBM stressing is done in accordance with the ANSI/ESDA/JEDEC JS-001 specification.

6.3 Recommended Operating Conditions

		MIN	MAX	UNIT
V _{BB}	Power supply voltage	8	38	V
V _{DD}	Logic voltage	0	5.5	V
f _{PWM}	Applied PWM signal (PHASE and ENABLE)	0	100	kHz
T _A	Ambient temperature	-40	125	°C

6.4 Thermal Information

THERMAL METRIC ⁽¹⁾		DRV8801-Q1		UNIT
		RTY (QFN)		
		16 PINS		
R _{θJA}	Junction-to-ambient thermal resistance	46.1		°C/W
R _{θJC(top)}	Junction-to-case (top) thermal resistance	43.0		°C/W
R _{θJB}	Junction-to-board thermal resistance	22.5		°C/W
ψ _{JT}	Junction-to-top characterization parameter	0.6		°C/W
ψ _{JB}	Junction-to-board characterization parameter	22.5		°C/W
R _{θJC(bot)}	Junction-to-case (bottom) thermal resistance	3.8		°C/W

- (1) For more information about traditional and new thermal metrics, see the *Semiconductor and IC Package Thermal Metrics* application report, [SPRA953](#).

6.5 Electrical Characteristics

over recommended operating conditions (unless otherwise noted)

PARAMETER		TEST CONDITIONS	MIN	TYP	MAX	UNIT	
POWER SUPPLIES (VBB)							
VBB	VBB operating voltage		8		38	V	
I _{VBB}	VBB operating supply current	f _{PWM} < 50 kHz		6		mA	
		Charge pump on, outputs disabled		3.2			
I _{VBBQ}	VBB sleep-mode supply current	nSLEEP = 0, T _J = 25°C			10	μA	
CONTROL INPUTS (PHASE, ENABLE, MODE1, MODE2, nSLEEP)							
V _{IL}	Input logic low voltage	PHASE, ENABLE, MODE1, MODE2			0.8	V	
V _{IH}	Input logic high voltage		2				
V _{IHYS}	Input hysteresis		100	500	800	mV	
I _{IL}	Input logic low current	PHASE, MODE1, MODE2	V _{IN} = 0.8 V	-20	< -2	20	μA
I _{IH}	Input logic high current		V _{IN} = 2.0 V		< 1	20	
I _{IL}	Input logic low current	ENABLE	V _{IN} = 0.8 V		16	40	μA
I _{IH}	Input logic high current		V _{IN} = 2.0 V		40	100	
V _{IL}	Input logic low voltage	nSLEEP			0.8	V	
V _{IH}	Input logic high voltage		2.7			V	
I _{IL}	Input logic low current		V _{IN} = 0.8 V		< 1	10	μA
I _{IH}	Input logic high current		V _{IN} = 2.7 V		27	50	
CONTROL OUTPUTS (nFAULT)							
V _{OL}	Output logic low voltage	I _O = 1 mA			0.4	V	
VBBNFR	VBB nFAULT release	8 V < VBB < 40 V		12	13.8	V	
DMOS DRIVERS (OUT+, OUT-, SENSE, VPROPI)							
R _{DS(on)}	Output ON resistance	Source driver, I _{OUT} = -2.8 A, T _J = 25°C		0.48		Ω	
		Source driver, I _{OUT} = -2.8 A, T _J = 125°C		0.74	0.85		
		Sink driver, I _{OUT} = 2.8 A, T _J = 25°C		0.35			
		Sink driver, I _{OUT} = 2.8 A, T _J = 125°C		0.52	0.7		
V _{TRIP}	SENSE trip voltage	R _{SENSE} between SENSE and GND		500		mV	
V _f	Body diode forward voltage	Source diode, I _f = -2.8 A			1.4	V	
		Sink diode, I _f = 2.8 A			1.4		
A _{VDA}	Differential AMP gain	SENSE = 0.1 V to 0.4 V		5		V/V	
PROTECTION CIRCUITRY							
VUV	UVLO threshold	VBB increasing		6.5	7.5	V	
I _{OCP}	Overcurrent protection trip level	VBB = 8.0 approximately 38 V		3		A	
T _{OTW}	Thermal warning temperature	Die temperature T _J ⁽¹⁾		160		°C	
T _{OTW HYS}	Thermal warning hysteresis	Die temperature T _J		15		°C	
T _{OTS}	Thermal shutdown temperature	Die temperature T _J ⁽²⁾		175		°C	
T _{OTS HYS}	Thermal shutdown hysteresis	Die temperature T _J		15		°C	

- Once the device reaches the thermal warning temperature of 160°C, the device remains in thermal warning until the device cools to 145°C. This is known as the thermal-warning hysteresis of the device.
- Once the device reaches the thermal shutdown temperature of 175°C, the device remains in thermal shutdown until the device cools to 160°C. This is known as the thermal-shutdown hysteresis of the device.

6.6 Timing Requirements

			MIN	NOM	MAX	UNIT
t_{pd}	Propagation delay time	Input edge to source or sink ON		600		ns
		Input edge to source or sink OFF		100		
t_{COD}	Crossover delay			500		ns
t_{DEG}	Overcurrent deglitch time			3		μ s
t_{OCP}	Overcurrent retry time			1.2		ms

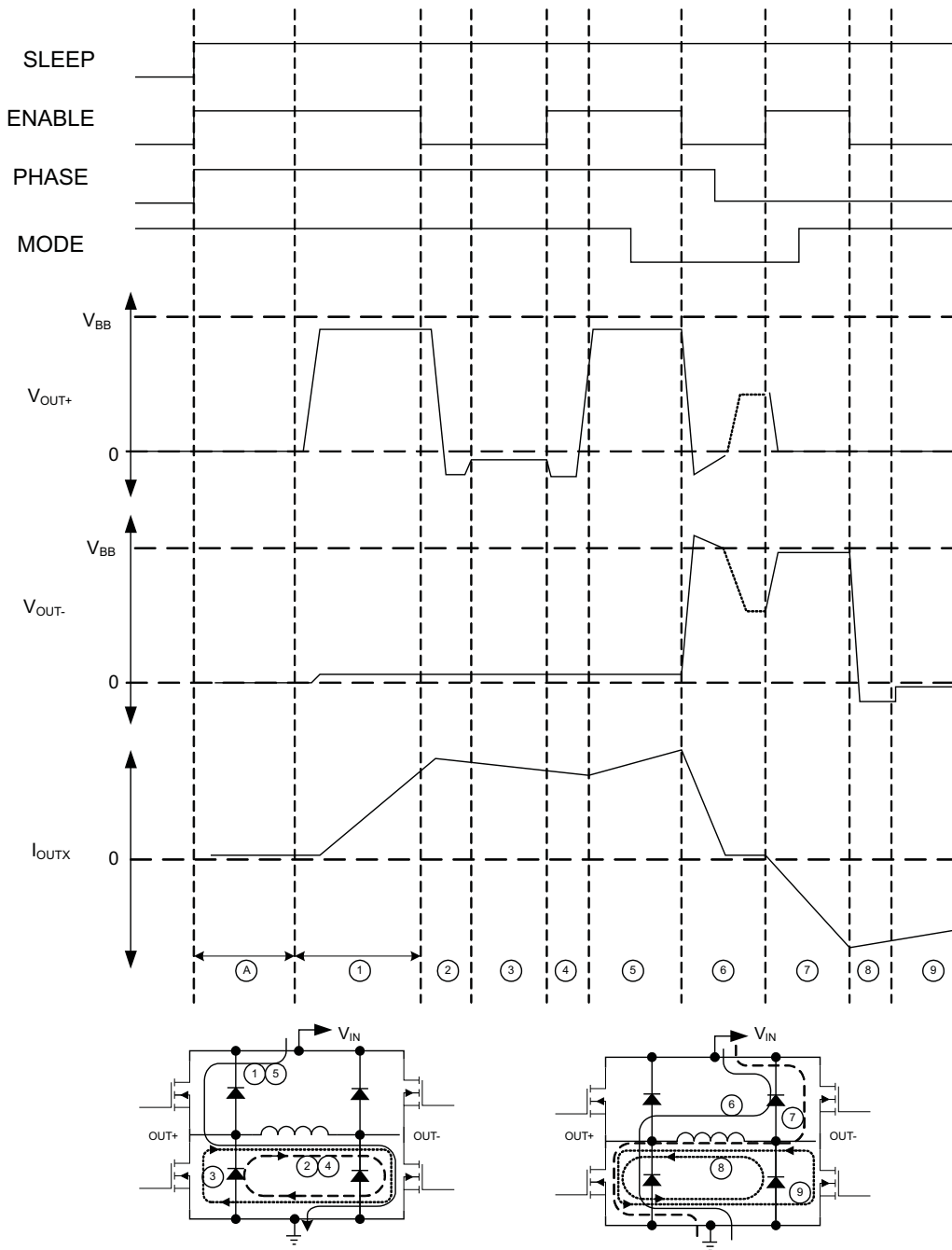

(A) Charge Pump and VREG power on delay (~200 us)

Figure 1. PWM Control Timing

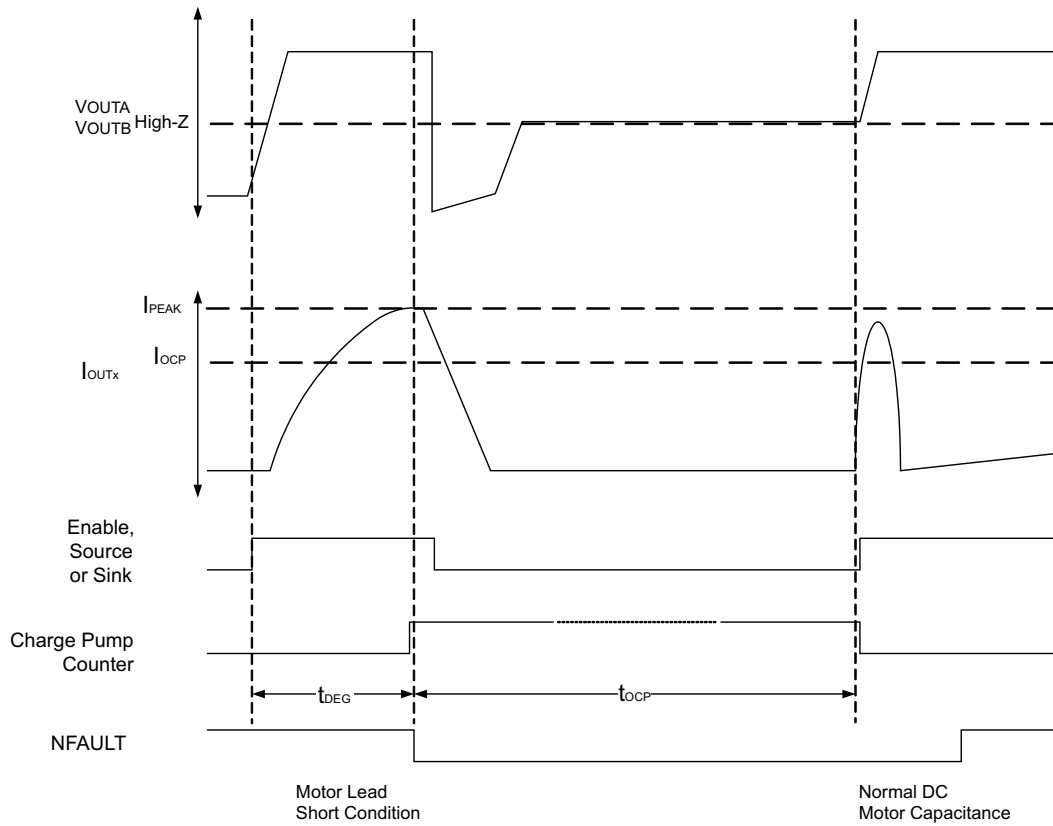

Figure 2. Overcurrent Control Timing

6.7 Typical Characteristics

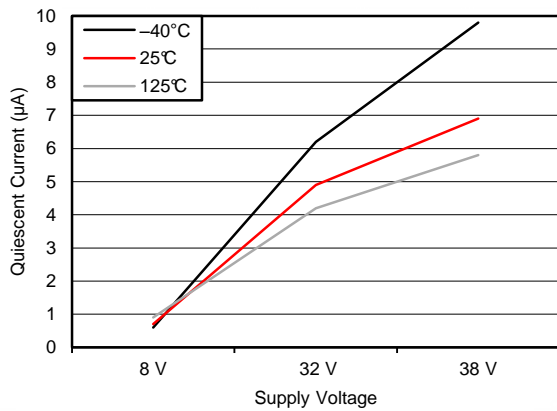

Figure 3. I_{VBBQ} vs V_{BB}

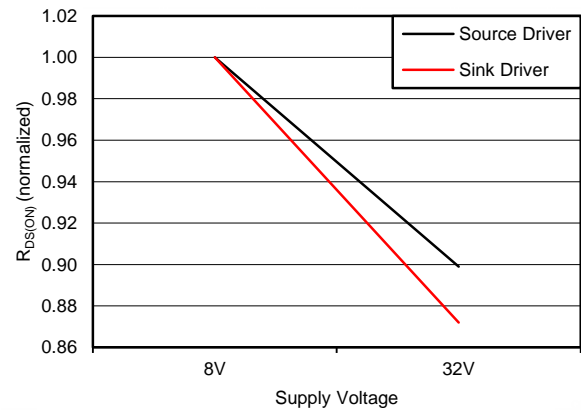

Figure 4. $R_{DS(ON)}$ vs V_{BB} (Normalized to $V_{BB} = 8\text{ V}$)

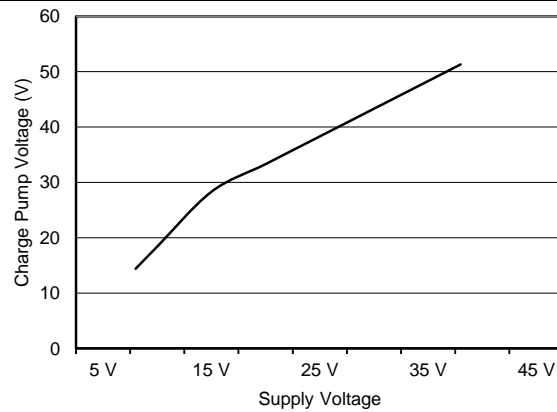

Figure 5. V_{CP} vs V_{BB}

7 Detailed Description

7.1 Overview

The DRV8801-Q1 is an integrated motor driver solution for brushed-DC motors. The device integrates a DMOS H-bridge and current sense and protection circuitry. The device can be powered with a supply voltage between 8 and 38 V, and is capable of providing an output current up to 2.8 A peak.

A simple PHASE-ENABLE interface allows control of the motor speed and direction.

A shunt amplifier output is provided for accurate current measurements by the system controller. The VPROPI pin will output a voltage that is 5 times the voltage seen at the SENSE pin.

A low-power sleep mode is included which allows the system to save power when not driving the motor.

7.2 Functional Block Diagram

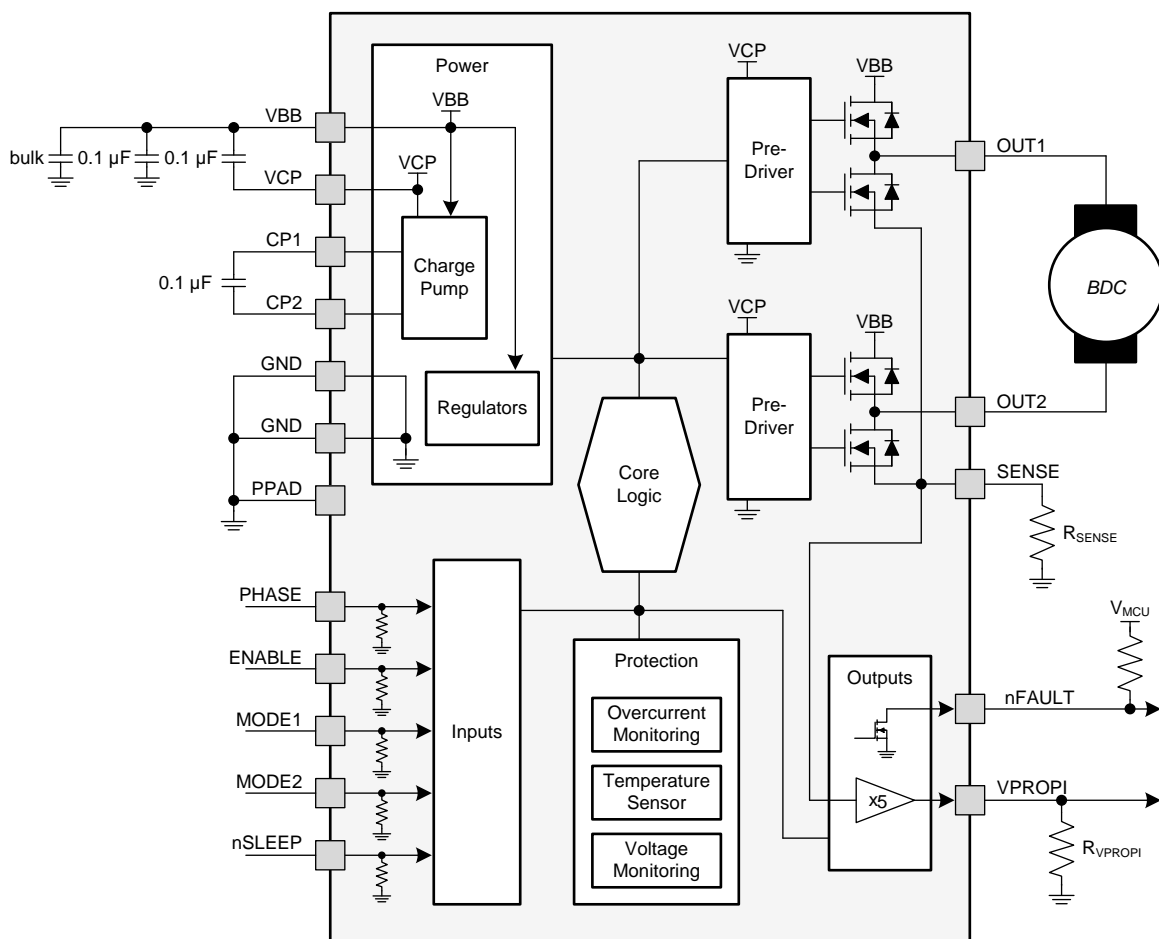

Copyright © 2016, Texas Instruments Incorporated

7.3 Feature Description

7.3.1 Power Supervisor

The control input, nSLEEP, is used to minimize power consumption when the DRV8801-Q1 device is not in use. The nSLEEP input disables much of the internal circuitry, including the internal voltage rails and charge pump. nSLEEP is asserted logic low. A logic high on this input pin results in normal operation. When switching from low to high, the user should allow a 1-ms delay before applying PWM signals. This time is needed for the charge pump to stabilize.

Feature Description (continued)

7.3.2 Bridge Control

Table 1 shows the logic for the DRV8801-Q1:

Table 1. Bridge Control Logic Table

nSLEEP	PHASE	ENABLE	MODE1	MODE2	OUTA	OUTB	OPERATION
0	X	X	X	X	Z	Z	Sleep mode
1	0	1	X	X	L	H	Reverse
1	1	1	X	X	H	L	Forward
1	0	0	0	X	H	L	Fast decay
1	1	0	0	X	L	H	Fast decay
1	X	0	1	0	L	L	Low-side Slow decay
1	X	0	1	1	H	H	High-side Slow decay

To prevent reversal of current during fast-decay synchronous rectification, outputs go to the high impedance state as the current approaches 0 A.

The path of current flow for each of the states in the above logic table is shown in [Figure 6](#).

7.3.2.1 MODE 1

Input MODE 1 is used to toggle between fast-decay mode and slow-decay mode. A logic high puts the device in slow-decay mode.

7.3.2.2 MODE 2

MODE 2 is used to select which set of drivers (high side versus low side) is used during the slow-decay recirculation. MODE 2 is meaningful only when MODE 1 is asserted high. A logic high on MODE 2 has current recirculation through the high-side drivers. A logic low has current recirculation through the low-side drivers.

7.3.3 Fast Decay with Synchronous Rectification

This decay mode is equivalent to a phase change where the FETs opposite of the driving FETs are switched on (2 in [Figure 6](#)). When in fast decay, the motor current is not allowed to go negative because this would cause a change in direction. Instead, as the current approaches zero, the drivers turn off. See the [Power Dissipation](#) section for an equation to calculate power.

7.3.4 Slow Decay with Synchronous Rectification (Brake Mode)

In slow-decay mode, both low-side and high-side drivers turn on, allowing the current to circulate through the low-side and high-side body diodes of the H-bridge and the load (3 and 4 in [Figure 6](#)). See the [Power Dissipation](#) section for equations to calculate power for both high-side and low-side slow decay.

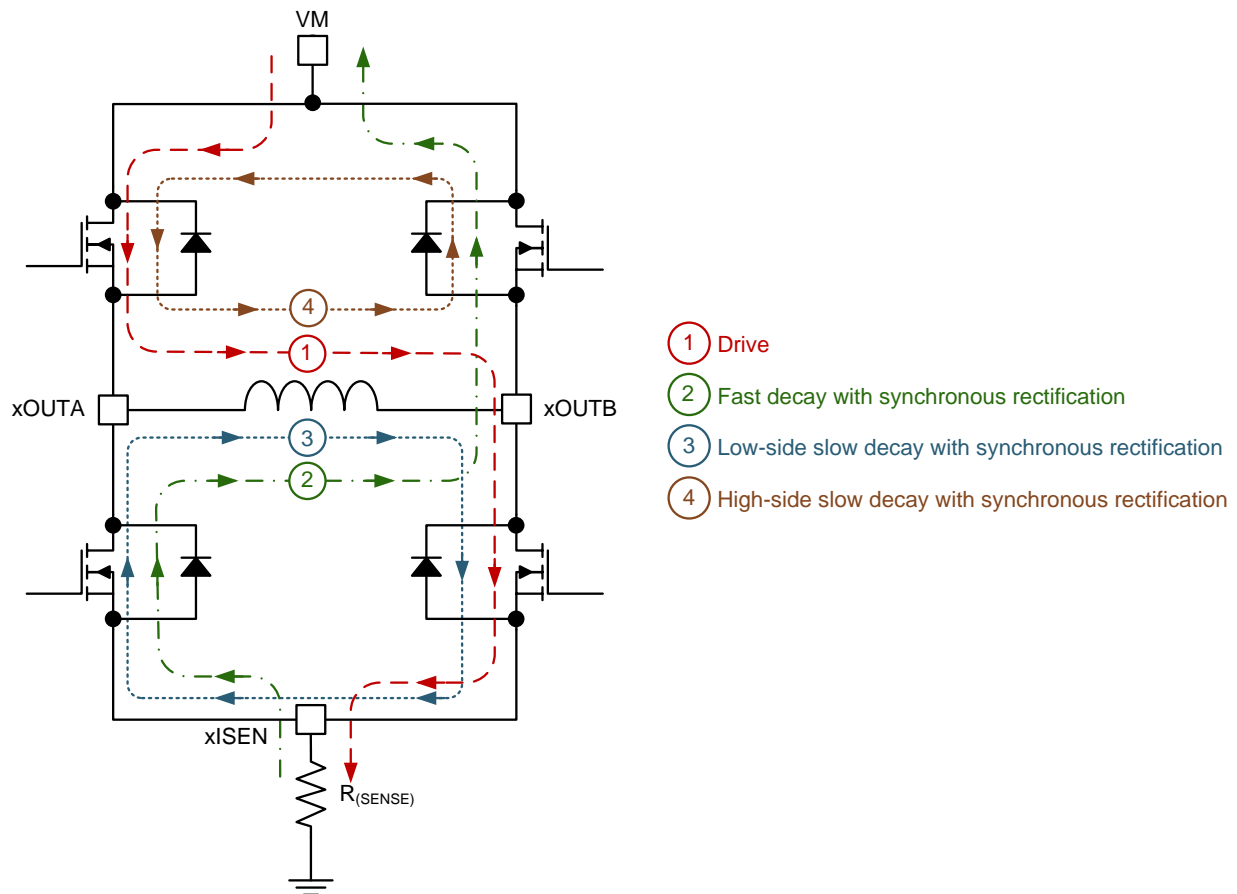

Figure 6. H-Bridge Operation Modes

7.3.5 Charge Pump

The charge pump is used to generate a supply above V_{BB} to drive the source-side DMOS gates. A 0.1- μF ceramic monolithic capacitor should be connected between CP1 and CP2 for pumping purposes. A 0.1- μF ceramic monolithic capacitor should be connected between VCP and V_{BB} to act as a reservoir to run the high-side DMOS devices.

7.3.6 SENSE

A low-value resistor can be placed between the SENSE pin and ground for current-sensing purposes. To minimize ground-trace IR drops in sensing the output current level, the current-sensing resistor should have an independent ground return to the star ground point. This trace should be as short as possible. For low-value sense resistors, the IR drops in the PCB can be significant, and should be taken into account.

To set a manual overcurrent trip threshold, place a resistor between the SENSE pin and GND. When the SENSE pin rises above 500 mV, the H-bridge output is disabled (hi-Z). The device automatically retries with a period of $t_{(OCP)}$.

The overcurrent trip threshold can be calculated using Equation 1.

$$I_{(trip)} = 500 \text{ mV/R} \quad (1)$$

The overcurrent trip level selected cannot be greater than $I_{(OCP)}$.

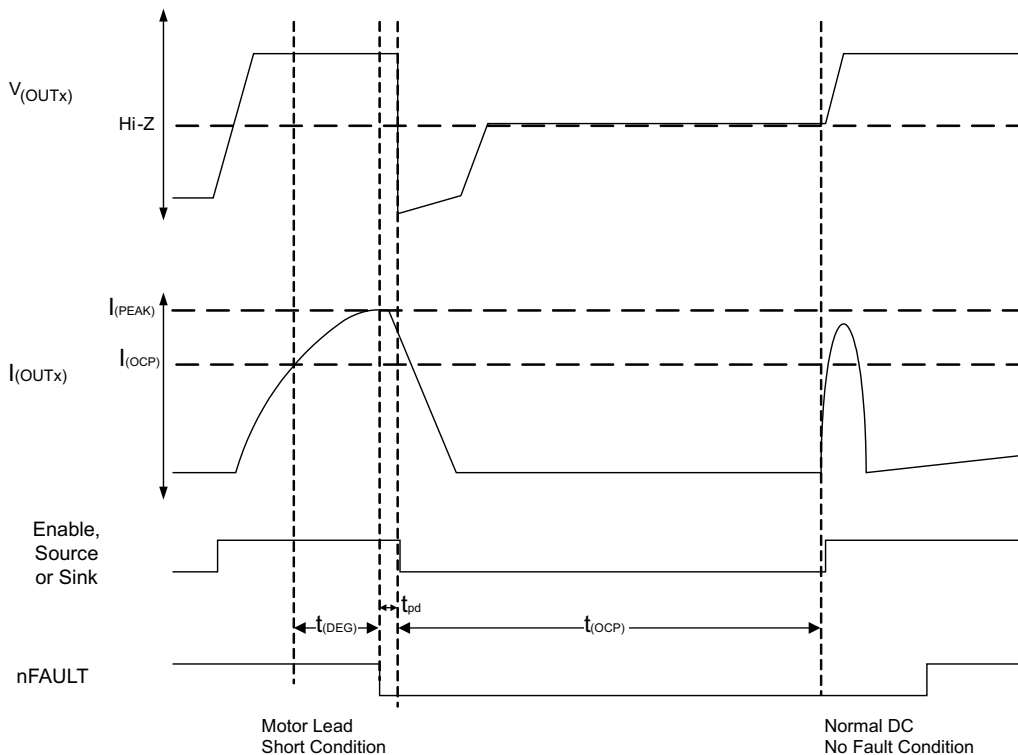

Figure 7. Overcurrent Control Timing

7.3.7 VPROPI

The VPROPI output is equal to approximately five times the voltage present on the SENSE pin. VPROPI is meaningful only if there is a resistor connected to the SENSE pin. If the SENSE pin is connected to ground, VPROPI measures 0 V. Also note that during slow decay (brake), VPROPI measures 0 V. VPROPI can output a maximum of 2.5 V, because at 500 mV on SENSE, the H-bridge is disabled.

7.3.8 Protection Circuits

The DRV8801-Q1 device is fully protected against V_{BB} undervoltage, overcurrent, and overtemperature events.

Table 2. DRV8801-Q1 Fault Responses

FAULT	ERROR REPORT	H-BRIDGE	CHARGE PUMP	RECOVERY
V_{BB} undervoltage (UVLO)	No error report – nFAULT is hi-Z	Disabled	Shut Down	$V_{BB} > V_{UVLO}$ RISING
Overcurrent (OCP)	nFAULT pulled low	Disabled	Operating	Retry time, $t_{(OCP)}$
Overtemperature Warning (OTW)	nFAULT pulled low	Enabled	Operating	$T_J < T_{(OTW)} - T_{hys(OTW)}$
Overtemperature Shutdown (OTS)	nFAULT remains pulled low (set during OTW)	Disabled	Shut Down	$T_J < T_{(OTS)} - T_{hys(OTS)}$

7.3.8.1 V_{BB} Undervoltage Lockout (UVLO)

If at any time the voltage on the V_{BB} pin falls below the undervoltage lockout threshold voltage, all FETs in the H-bridge are disabled and the charge pump is disabled. The nFAULT pin does not report the UVLO fault condition and remains hi-Z. Operation resumes when V_{BB} rises above the UVLO threshold.

7.3.8.2 Overcurrent Protection (OCP)

The current flowing through the high-side and low-side drivers is monitored to ensure that the motor lead is not shorted to supply or ground. If a short is detected, all FETs in the H-bridge are disabled, nFAULT is driven low, and a $t_{(OCP)}$ fault timer is started. After this period, $t_{(OCP)}$, the device is then allowed to follow the input commands and another turn-on is attempted (nFAULT releases during this attempt). If there is still a fault condition, the cycle repeats. If the short condition is not present after $t_{(OCP)}$ expires, normal operation resumes and nFAULT is released.

7.3.8.3 Overtemperature Warning (OTW)

If the die temperature increases past the thermal warning threshold the nFAULT pin is driven low. When the die temperature has fallen below the hysteresis level, the nFAULT pin is released. If the die temperature continues to increase, the device enters overtemperature shutdown as described in the [Overtemperature Shutdown \(OTS\)](#) section.

7.3.8.4 Overtemperature Shutdown (OTS)

If the die temperature exceeds the thermal shutdown temperature, all FETs in the H-bridge are disabled and the charge pump shuts down. The nFAULT pin remains pulled low during this fault condition. When the die temperature falls below the hysteresis threshold, operation automatically resumes.

7.3.9 Thermal Shutdown (TSD)

Two die-temperature monitors are integrated on the chip. As die temperature increases toward the maximum, a thermal warning signal is triggered at 160°C. This fault drives nFAULT low, but does not disable the operation of the chip. If the die temperature increases further, to approximately 175°C, the full-bridge outputs are disabled until the internal temperature falls below a hysteresis of 15°C.

7.4 Device Functional Modes

The DRV8801-Q1 device is active unless the nSLEEP pin is brought logic low. In sleep mode the charge pump is disabled and the H-bridge FETs are disabled hi-Z. The DRV8801-Q1 device is brought out of sleep mode automatically if nSLEEP is brought logic high.

8 Application and Implementation

NOTE

Information in the following applications sections is not part of the TI component specification, and TI does not warrant its accuracy or completeness. TI's customers are responsible for determining suitability of components for their purposes. Customers should validate and test their design implementation to confirm system functionality.

8.1 Application Information

The DRV8801-Q1 device is used in medium voltage brushed DC motor control applications.

8.2 Typical Application

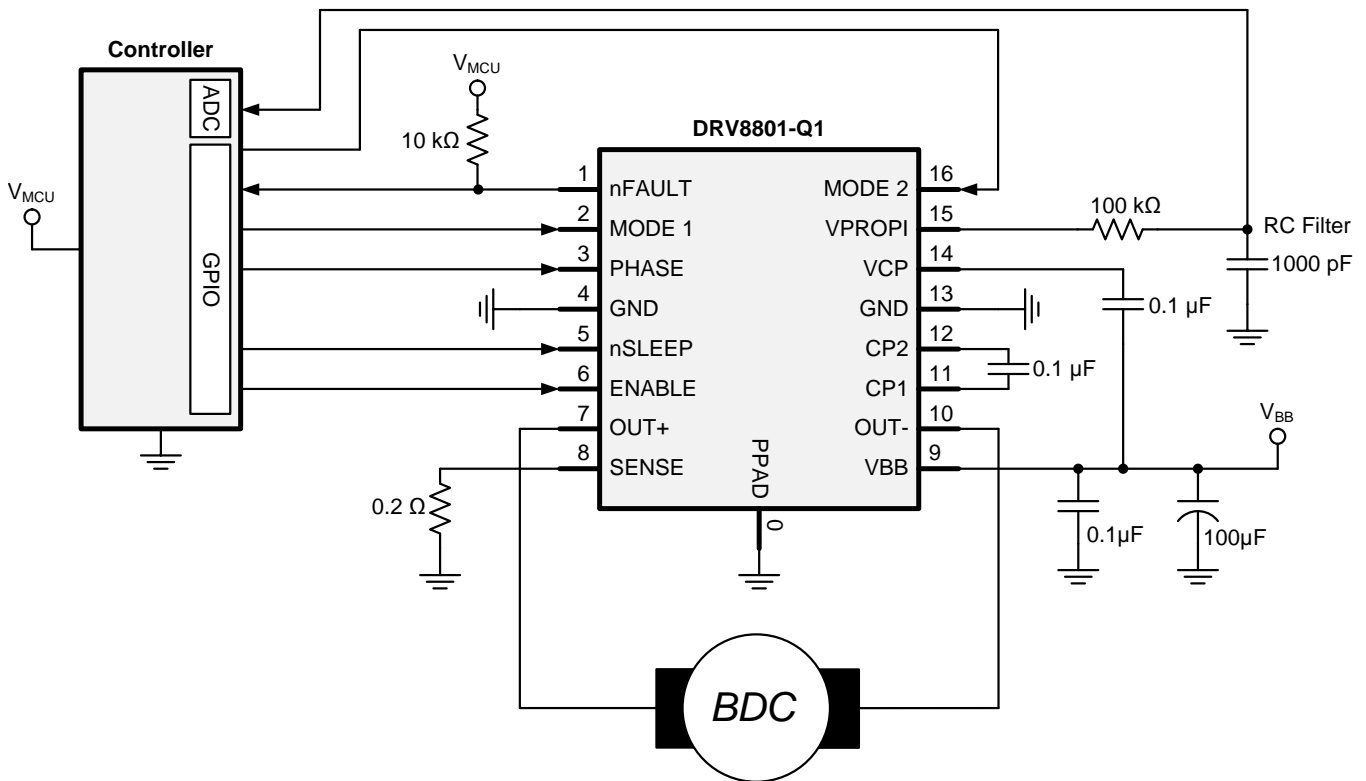

Figure 8. Typical Application Schematic

8.2.1 Design Requirements

For this design example, use the parameters listed in Table 3 as the input parameters.

Table 3. Design Parameters

DESIGN PARAMETER	REFERENCE	EXAMPLE VALUE
Motor Voltage	VBB	24 V
Motor RMS Current	IRMS	0.8 A
Motor Startup Current	ISTART	2 A
Motor Current Trip Point	ITRIP	2.5 A

8.2.2 Detailed Design Procedure

8.2.2.1 Motor Voltage

The motor voltage to use will depend on the ratings of the motor selected and the desired RPM. A higher voltage spins a brushed DC motor faster with the same PWM duty cycle applied to the power FETs. A higher voltage also increases the rate of current change through the inductive motor windings.

8.2.2.2 Power Dissipation

The power dissipation of the DRV8801-Q1 is a function of the RMS motor current and the each output's FET resistance ($R_{DS(ON)}$).

$$\text{Power} \approx I_{RMS}^2 \times (\text{High-Side } R_{DS(ON)} + \text{Low-Side } R_{DS(ON)}) \quad (2)$$

For this example, the ambient temperature is 35°C, and the junction temperature reaches 65°C. At 65°C, the sum of $R_{DS(ON)}$ is about 1 Ω. With an example motor current of 0.8 A, the dissipated power in the form of heat will be $0.8 \text{ A}^2 \times 1 \text{ } \Omega = 0.64 \text{ W}$.

The temperature that the DRV8801-Q1 reaches will depend on the thermal resistance to the air and PCB. It is important to solder the device thermal pad to the PCB ground plane, with vias to the top and bottom board layers, to dissipate heat into the PCB and reduce the device temperature. In the example used here, the DRV8801-Q1 had an effective thermal resistance $R_{\theta JA}$ of 47°C/W, and:

$$T_J = T_A + (P_D \times R_{\theta JA}) = 35^\circ\text{C} + (0.64 \text{ W} \times 47^\circ\text{C/W}) = 65^\circ\text{C} \quad (3)$$

8.2.2.3 Motor Current Trip Point

When the voltage on pin SENSE exceeds V_{TRIP} (0.5 V), overcurrent is detected. The R_{SENSE} resistor should be sized to set the desired I_{TRIP} level.

$$R_{SENSE} = 0.5 \text{ V} / I_{TRIP} \quad (4)$$

To set I_{TRIP} to 2.5 A, $R_{SENSE} = 0.5 \text{ V} / 2.5 \text{ A} = 0.2 \text{ } \Omega$.

To prevent false trips, I_{TRIP} must be higher than regular operating current. Motor current during startup is typically much higher than steady-state spinning, because the initial load torque is higher, and the absence of back-EMF causes a higher voltage and extra current across the motor windings.

It is beneficial to limit startup current by using series inductors on the DRV8801-Q1 output, as that allows I_{TRIP} to be lower, and it may decrease the system's required bulk capacitance. Startup current can also be limited by ramping the forward drive duty cycle.

8.2.2.4 Sense Resistor Selection

For optimal performance, it is important for the sense resistor to be:

- Surface-mount
- Low inductance
- Rated for high enough power
- Placed closely to the motor driver

8.2.2.5 Drive Current

This current path is through the high-side sourcing DMOS driver, motor winding, and low-side sinking DMOS driver. Power dissipation I^2R losses in one source and one sink DMOS driver, as shown in [Equation 5](#).

$$P_D = I^2 (r_{DS(on)Source} + r_{DS(on)Sink}) \quad (5)$$

8.2.3 Application Curves

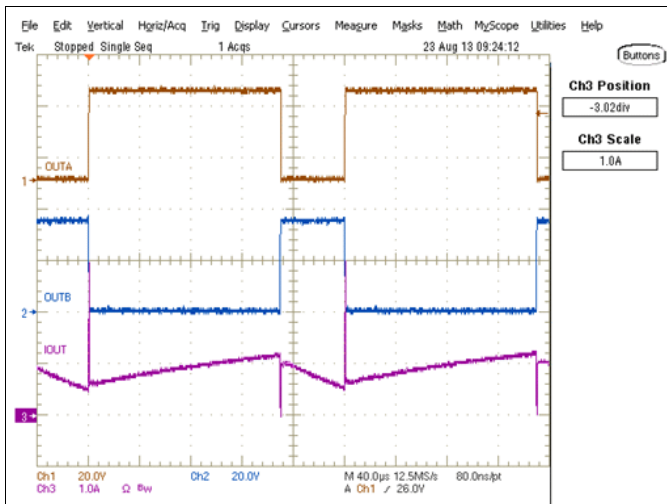

Figure 9. Forward Drive, Fast Decay

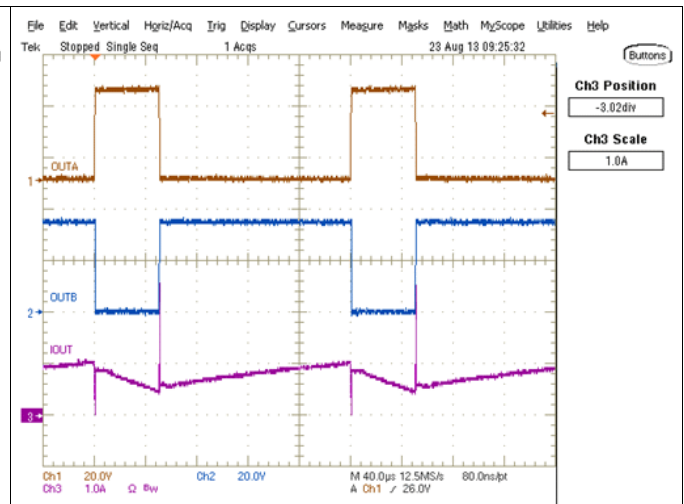

Figure 10. Reverse Drive, Fast Decay

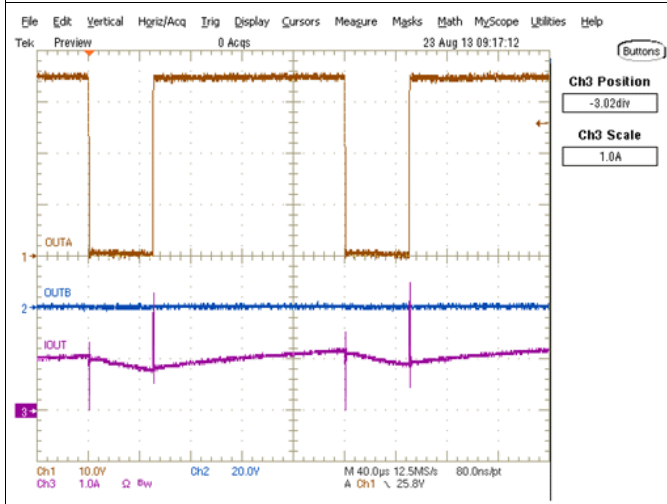

Figure 11. Forward Drive, Slow Decay

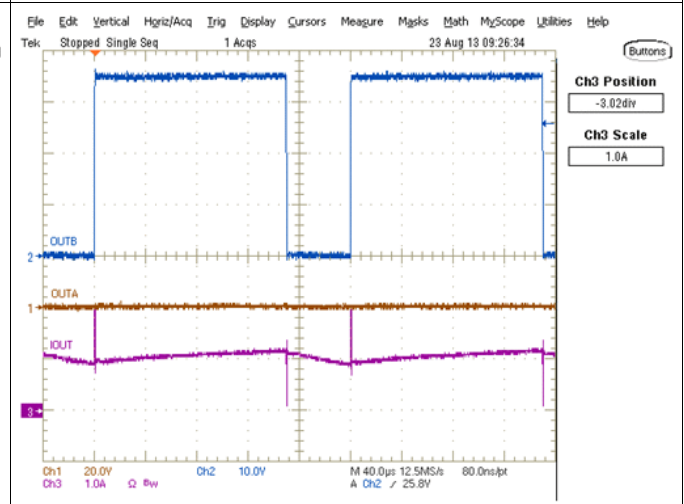

Figure 12. Reverse Drive, Slow Decay

9 Power Supply Recommendations

9.1 Bulk Capacitance

Having appropriate local bulk capacitance is an important factor in motor drive system design. It is generally beneficial to have more bulk capacitance, while the disadvantages are increased cost and physical size.

The amount of local capacitance needed depends on a variety of factors, including:

- The highest current required by the motor system.
- The capacitance of the power supply and its ability to source current.
- The amount of parasitic inductance between the power supply and motor systems.
- The acceptable voltage ripple.
- The type of motor used (Brushed DC, Brushless DC, Stepper).
- The motor braking method.

The inductance between the power supply and motor drive system will limit the rate current can change from the power supply. If the local bulk capacitance is too small, the system will respond to excessive current demands or dumps from the motor with a change in voltage. When adequate bulk capacitance is used, the motor voltage remains stable and high current can be quickly supplied.

The data sheet generally provides a recommended value, but system-level testing is required to determine the appropriate sized bulk capacitor.

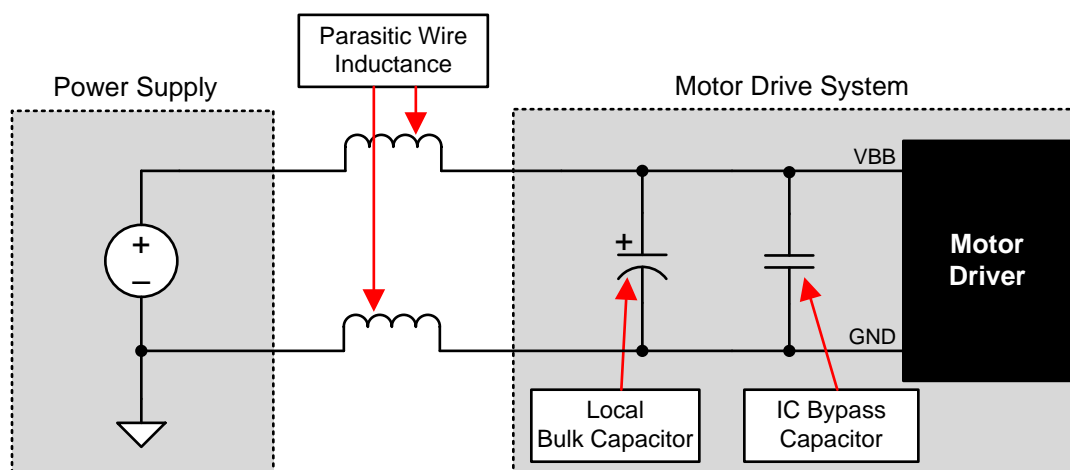

Figure 13. Example Setup of Motor Drive System With External Power Supply

10 Layout

10.1 Layout Guidelines

- The printed-circuit-board (PCB) should use a heavy ground plane. For optimal electrical and thermal performance, the DRV8801-Q1 must be soldered directly onto the board. On the underside of the DRV8801-Q1 is a thermal pad, which provides a path for enhanced thermal dissipation. The thermal pad should be soldered directly to an exposed surface on the PCB. Thermal vias are used to transfer heat to other layers of the PCB.
- The load supply pin VBB, should be decoupled with an electrolytic capacitor (typically 100 μF) in parallel with a ceramic capacitor (0.1 μF) placed as close as possible to the device.
- The ceramic capacitors (0.1 μF) between VCP and VBB and between CP1 and CP2 should be placed as close as possible to the device.
- The SENSE resistor should be close as possible to the SENSE pin and ground return to minimize parasitic inductance.

10.2 Layout Example

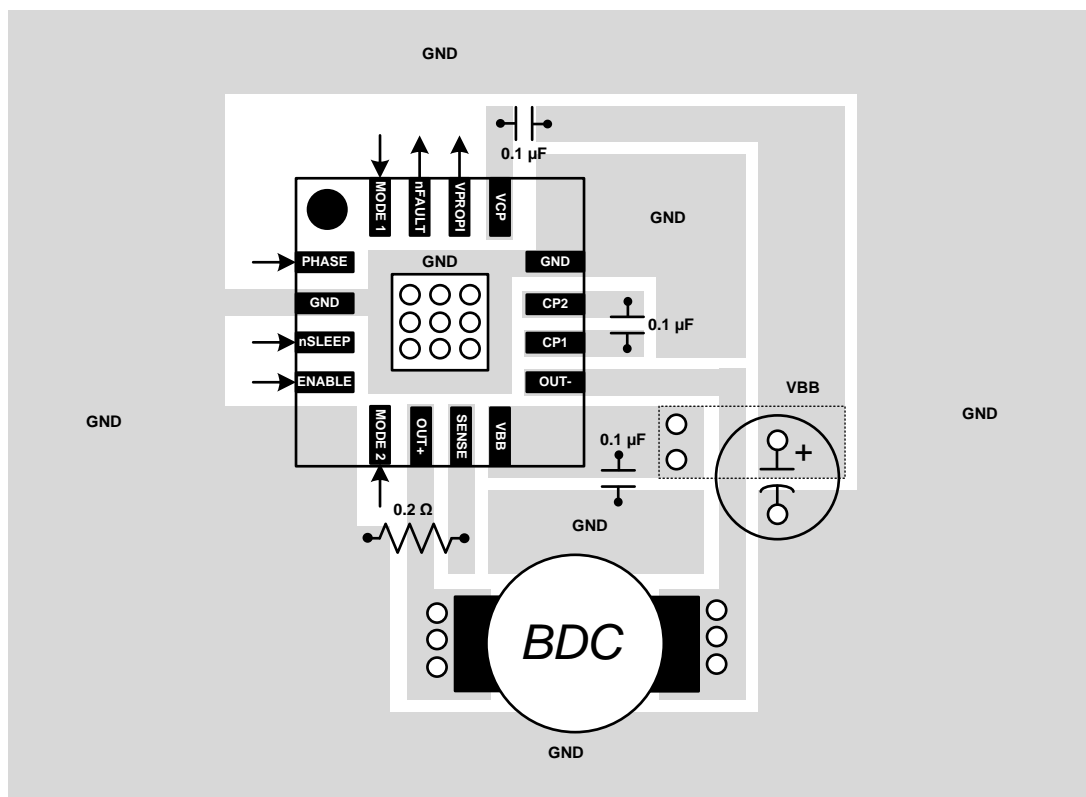

Figure 14. RTY Layout Example

11 Device and Documentation Support

11.1 Documentation Support

11.1.1 Related Documentation

For related documentation, see the following:

[QFN/SON PCB Attachment](#)

11.2 Receiving Notification of Documentation Updates

To receive notification of documentation updates, navigate to the device product folder on ti.com. In the upper right corner, click on *Alert me* to register and receive a weekly digest of any product information that has changed. For change details, review the revision history included in any revised document.

11.3 Community Resources

The following links connect to TI community resources. Linked contents are provided "AS IS" by the respective contributors. They do not constitute TI specifications and do not necessarily reflect TI's views; see TI's [Terms of Use](#).

TI E2E™ Online Community *TI's Engineer-to-Engineer (E2E) Community*. Created to foster collaboration among engineers. At e2e.ti.com, you can ask questions, share knowledge, explore ideas and help solve problems with fellow engineers.

Design Support *TI's Design Support* Quickly find helpful E2E forums along with design support tools and contact information for technical support.

11.4 Trademarks

E2E is a trademark of Texas Instruments.
All other trademarks are the property of their respective owners.

11.5 Electrostatic Discharge Caution



These devices have limited built-in ESD protection. The leads should be shorted together or the device placed in conductive foam during storage or handling to prevent electrostatic damage to the MOS gates.

11.6 Glossary

[SLYZ022](#) — *TI Glossary*.

This glossary lists and explains terms, acronyms, and definitions.

12 Mechanical, Packaging, and Orderable Information

The following pages include mechanical, packaging, and orderable information. This information is the most current data available for the designated devices. This data is subject to change without notice and revision of this document. For browser-based versions of this data sheet, refer to the left-hand navigation.

PACKAGING INFORMATION

Orderable Device	Status (1)	Package Type	Package Drawing	Pins	Package Qty	Eco Plan (2)	Lead/Ball Finish (6)	MSL Peak Temp (3)	Op Temp (°C)	Device Marking (4/5)	Samples
DRV8801QRTYRQ1	ACTIVE	QFN	RTY	16	3000	Green (RoHS & no Sb/Br)	NIPDAU	Level-3-260C-168 HR	-40 to 125	DRV 8801Q	Samples

(1) The marketing status values are defined as follows:

ACTIVE: Product device recommended for new designs.

LIFEBUY: TI has announced that the device will be discontinued, and a lifetime-buy period is in effect.

NRND: Not recommended for new designs. Device is in production to support existing customers, but TI does not recommend using this part in a new design.

PREVIEW: Device has been announced but is not in production. Samples may or may not be available.

OBSELETE: TI has discontinued the production of the device.

(2) **RoHS:** TI defines "RoHS" to mean semiconductor products that are compliant with the current EU RoHS requirements for all 10 RoHS substances, including the requirement that RoHS substance do not exceed 0.1% by weight in homogeneous materials. Where designed to be soldered at high temperatures, "RoHS" products are suitable for use in specified lead-free processes. TI may reference these types of products as "Pb-Free".

RoHS Exempt: TI defines "RoHS Exempt" to mean products that contain lead but are compliant with EU RoHS pursuant to a specific EU RoHS exemption.

Green: TI defines "Green" to mean the content of Chlorine (Cl) and Bromine (Br) based flame retardants meet JS709B low halogen requirements of <=1000ppm threshold. Antimony trioxide based flame retardants must also meet the <=1000ppm threshold requirement.

(3) MSL, Peak Temp. - The Moisture Sensitivity Level rating according to the JEDEC industry standard classifications, and peak solder temperature.

(4) There may be additional marking, which relates to the logo, the lot trace code information, or the environmental category on the device.

(5) Multiple Device Markings will be inside parentheses. Only one Device Marking contained in parentheses and separated by a "~" will appear on a device. If a line is indented then it is a continuation of the previous line and the two combined represent the entire Device Marking for that device.

(6) Lead/Ball Finish - Orderable Devices may have multiple material finish options. Finish options are separated by a vertical ruled line. Lead/Ball Finish values may wrap to two lines if the finish value exceeds the maximum column width.

Important Information and Disclaimer:The information provided on this page represents TI's knowledge and belief as of the date that it is provided. TI bases its knowledge and belief on information provided by third parties, and makes no representation or warranty as to the accuracy of such information. Efforts are underway to better integrate information from third parties. TI has taken and continues to take reasonable steps to provide representative and accurate information but may not have conducted destructive testing or chemical analysis on incoming materials and chemicals. TI and TI suppliers consider certain information to be proprietary, and thus CAS numbers and other limited information may not be available for release.

In no event shall TI's liability arising out of such information exceed the total purchase price of the TI part(s) at issue in this document sold by TI to Customer on an annual basis.

OTHER QUALIFIED VERSIONS OF DRV8801-Q1 :

- Catalog: [DRV8801](#)

NOTE: Qualified Version Definitions:

- Catalog - TI's standard catalog product

TAPE AND REEL INFORMATION



QUADRANT ASSIGNMENTS FOR PIN 1 ORIENTATION IN TAPE



*All dimensions are nominal

Device	Package Type	Package Drawing	Pins	SPQ	Reel Diameter (mm)	Reel Width W1 (mm)	A0 (mm)	B0 (mm)	K0 (mm)	P1 (mm)	W (mm)	Pin1 Quadrant
DRV8801QRTYRQ1	QFN	RTY	16	3000	330.0	12.4	4.25	4.25	1.15	8.0	12.0	Q2

TAPE AND REEL BOX DIMENSIONS



*All dimensions are nominal

Device	Package Type	Package Drawing	Pins	SPQ	Length (mm)	Width (mm)	Height (mm)
DRV8801QRTYRQ1	QFN	RTY	16	3000	853.0	449.0	35.0

MECHANICAL DATA

RTY (S-PWQFN-N16)

PLASTIC QUAD FLATPACK NO-LEAD

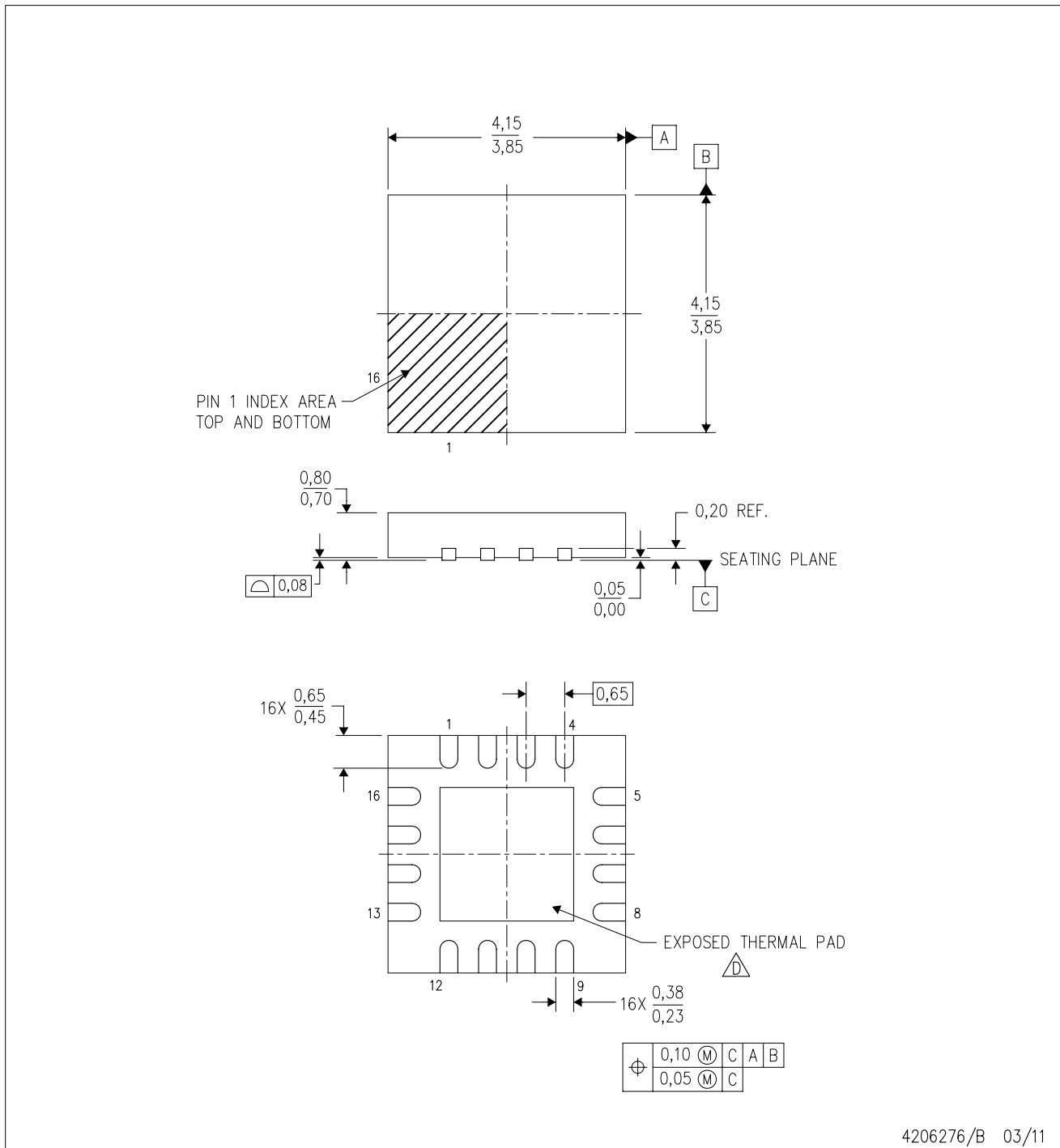

4206276/B 03/11

- NOTES:
- A. All linear dimensions are in millimeters. Dimensioning and tolerancing per ASME Y14.5-1994.
 - B. This drawing is subject to change without notice.
 - C. Quad Flatpack, No-leads (QFN) package configuration.
 - D. The package thermal pad must be soldered to the board for thermal and mechanical performance. See the Product Data Sheet for details regarding the exposed thermal pad dimensions.
 - E. Falls within JEDEC MO-220.

THERMAL PAD MECHANICAL DATA

RTY (S-PWQFN-N16)

PLASTIC QUAD FLATPACK NO-LEAD

THERMAL INFORMATION

This package incorporates an exposed thermal pad that is designed to be attached directly to an external heatsink. The thermal pad must be soldered directly to the printed circuit board (PCB). After soldering, the PCB can be used as a heatsink. In addition, through the use of thermal vias, the thermal pad can be attached directly to the appropriate copper plane shown in the electrical schematic for the device, or alternatively, can be attached to a special heatsink structure designed into the PCB. This design optimizes the heat transfer from the integrated circuit (IC).

For information on the Quad Flatpack No-Lead (QFN) package and its advantages, refer to Application Report, QFN/SON PCB Attachment, Texas Instruments Literature No. SLUA271. This document is available at www.ti.com.

The exposed thermal pad dimensions for this package are shown in the following illustration.

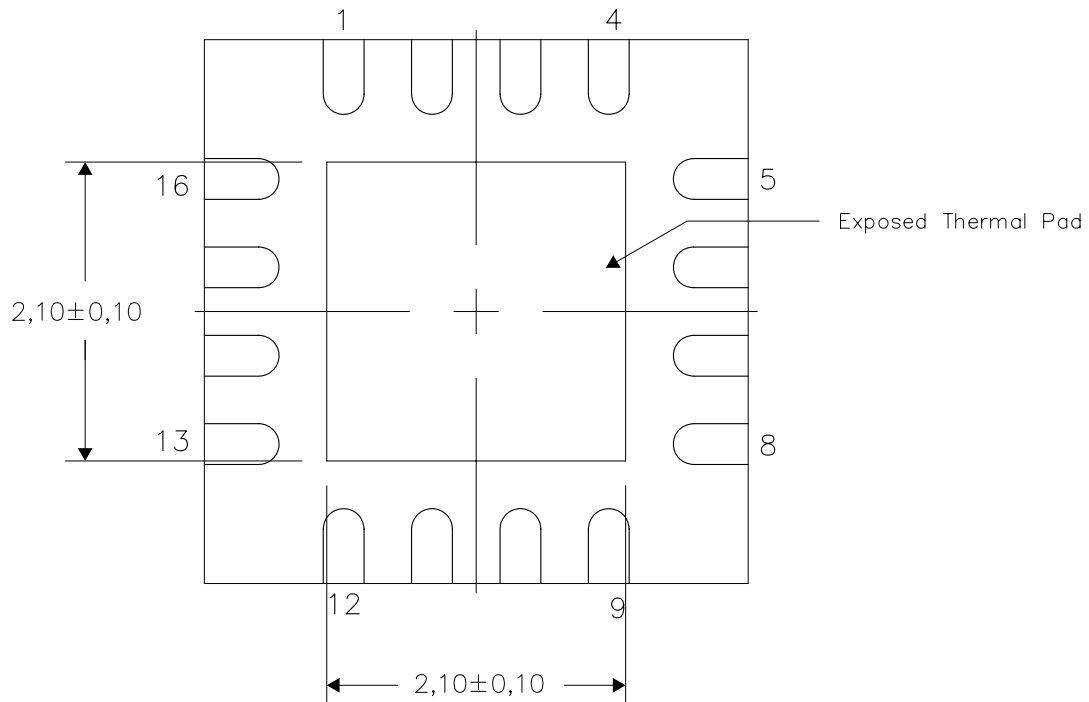

Bottom View

Exposed Thermal Pad Dimensions

4206277-2/E 03/11

NOTE: A. All linear dimensions are in millimeters

RTY (S-PWQFN-N16)

PLASTIC QUAD FLATPACK NO-LEAD

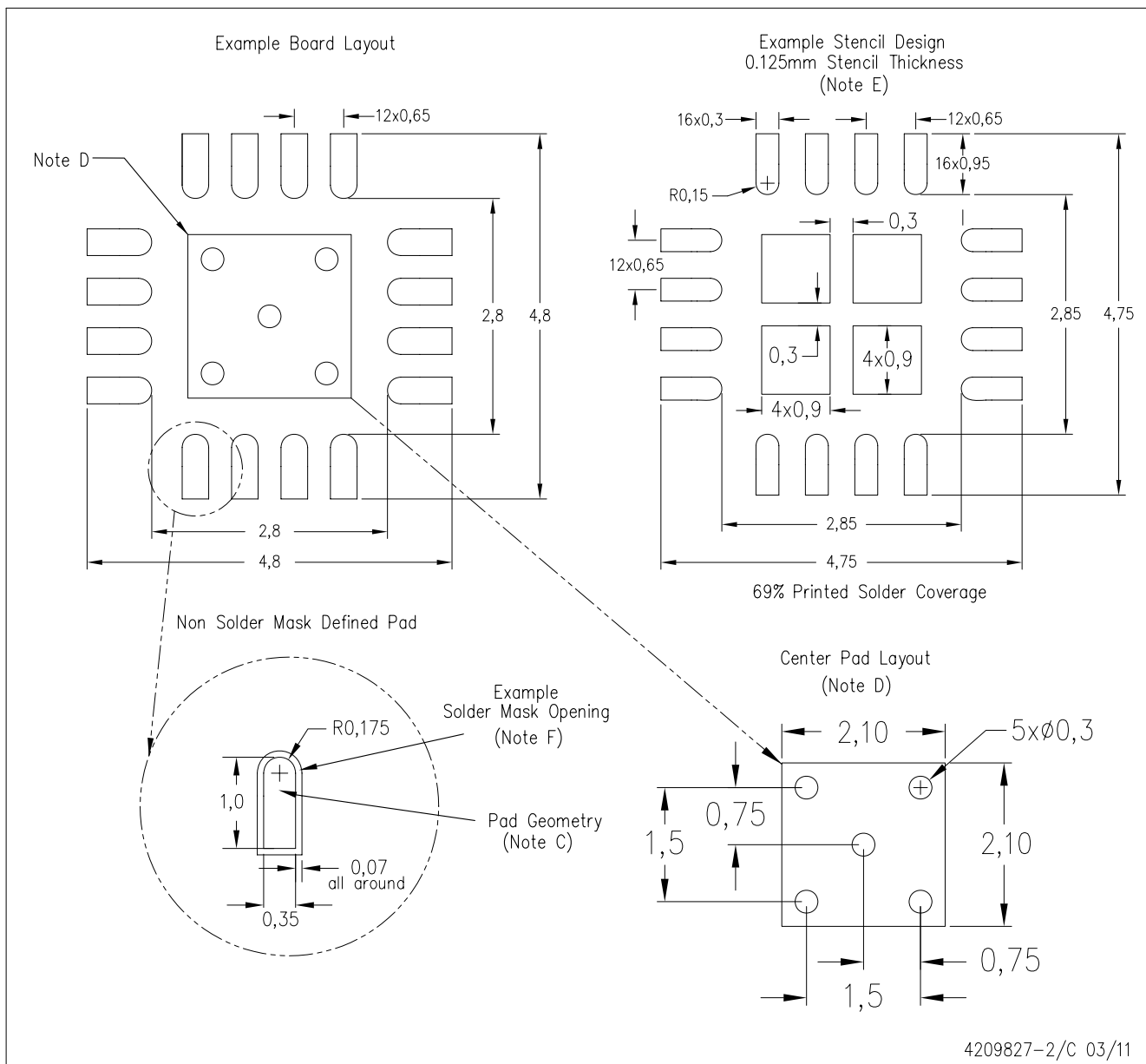

- NOTES: A. All linear dimensions are in millimeter.
 B. This drawing is subject to change without notice.
 C. Publication IPC-7351 is recommended for alternate designs.
 D. This package is designed to be soldered to a thermal pad on the board. Refer to Application Note, Quad Flat-Pack Packages, Texas Instruments Literature No. SLUA271, and also the Product Data Sheets for specific thermal information, via requirements, and recommended board layout. These documents are available at www.ti.com <<http://www.ti.com>>.
 E. Laser cutting apertures with trapezoidal walls and also rounding corners will offer better paste release. Customers should contact their board assembly site for stencil design recommendations. Refer to IPC 7525 for stencil design considerations.
 F. Customers should contact their board fabrication site for solder mask tolerances.

IMPORTANT NOTICE AND DISCLAIMER

TI PROVIDES TECHNICAL AND RELIABILITY DATA (INCLUDING DATASHEETS), DESIGN RESOURCES (INCLUDING REFERENCE DESIGNS), APPLICATION OR OTHER DESIGN ADVICE, WEB TOOLS, SAFETY INFORMATION, AND OTHER RESOURCES "AS IS" AND WITH ALL FAULTS, AND DISCLAIMS ALL WARRANTIES, EXPRESS AND IMPLIED, INCLUDING WITHOUT LIMITATION ANY IMPLIED WARRANTIES OF MERCHANTABILITY, FITNESS FOR A PARTICULAR PURPOSE OR NON-INFRINGEMENT OF THIRD PARTY INTELLECTUAL PROPERTY RIGHTS.

These resources are intended for skilled developers designing with TI products. You are solely responsible for (1) selecting the appropriate TI products for your application, (2) designing, validating and testing your application, and (3) ensuring your application meets applicable standards, and any other safety, security, or other requirements. These resources are subject to change without notice. TI grants you permission to use these resources only for development of an application that uses the TI products described in the resource. Other reproduction and display of these resources is prohibited. No license is granted to any other TI intellectual property right or to any third party intellectual property right. TI disclaims responsibility for, and you will fully indemnify TI and its representatives against, any claims, damages, costs, losses, and liabilities arising out of your use of these resources.

TI's products are provided subject to TI's Terms of Sale (www.ti.com/legal/termsofsale.html) or other applicable terms available either on ti.com or provided in conjunction with such TI products. TI's provision of these resources does not expand or otherwise alter TI's applicable warranties or warranty disclaimers for TI products.

Mailing Address: Texas Instruments, Post Office Box 655303, Dallas, Texas 75265
Copyright © 2020, Texas Instruments Incorporated