

Compact Cylinder

New

Remodeled with a new body to get more flexibility!

Can mount small auto switches on 4 surfaces.

Auto switches can be mounted on any of the 4 surfaces, depending on the installation conditions. (ø12 to ø25: 2 surfaces) Improved flexibility of system design.



**Auto switch mounting rail removed
A round slot for mounting small auto switches
is provided on 4 surfaces.**

NEW

Available up to ø200

NEW ø32 to ø200

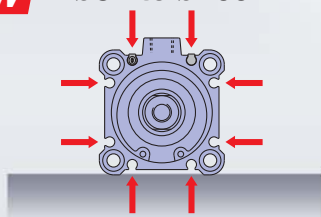

ø12 to ø25: Mountable on 2 surfaces

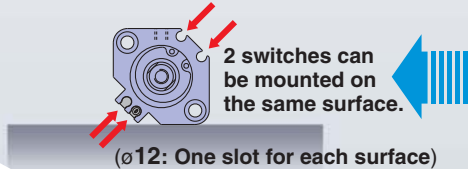

Existing model

ø32 to ø50: Only one surface

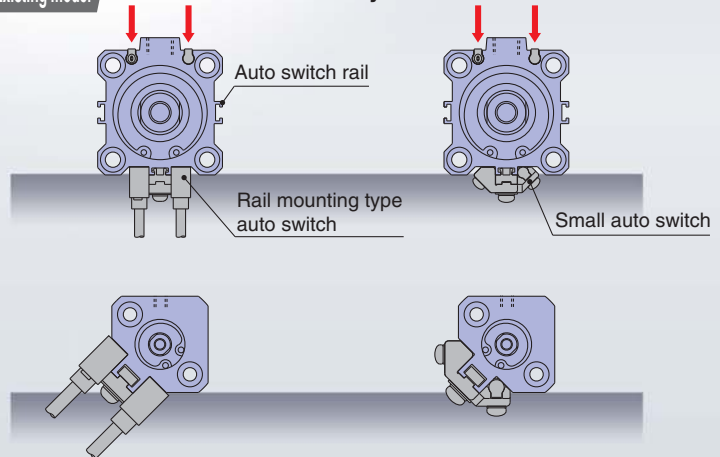

No protrusion of auto switch

- Prevention of damage to auto switch
- Sleeves cannot get caught in the auto switch and its mounting rail.
- ➡ Improved ease of work and safety
- Reduction in labour for design
There is no need to check for interference with a machine, because the outer dimensions of the cylinder do not change when the auto switch is mounted.

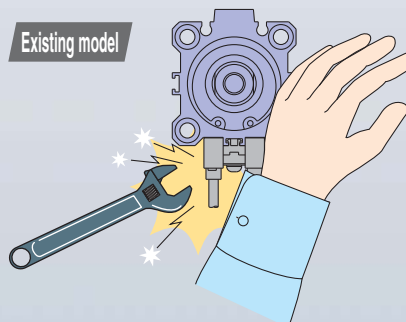

NEW

Exclusive bodies (-XB10) for ø32 to ø100 intermediate strokes (50 mm or more) now kept in inventory*, enabling shorter delivery times. * Formerly produced upon receipt of order

Bore size (mm)	Stroke										
	50	55	60	65	70	75	80	85	90	95	100
ø32 to ø100	◆	●	●	●	●	◆	●	●	●	●	◆

◆ Standard stroke ● Currently stocked intermediate stroke

Series CQ2



CAT.EUS20-205B-UK

NEW
Series **CQ2 Compact Cylinder**

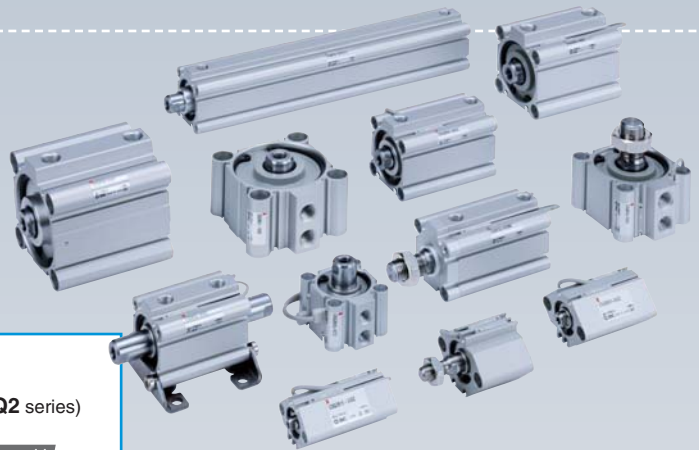

Lighter weight

Reduced by **5 to 13%**
NEW (Compared with SMC CQ2 series)

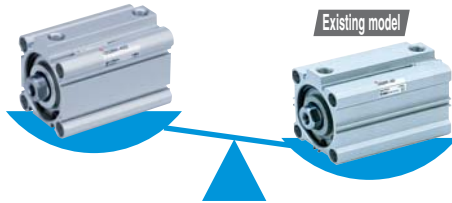

The body strength (kinetic energy, allowable load, withstand pressure, etc.) is the same as the existing product.

Contribution to environment and ecology
Reduction of CO₂ discharge by 1300 t by less use of aluminum

Weight

(Stroke 50 mm, built-in magnet, female thread and with rubber bumper) (g)

Bore size – Stroke	ø40-50 st
NEW CQ2	456(483)
Existing model CQ2	483(527)

(): With male thread

Small auto switch

2-colour indication solid state auto switch

◎ Appropriate setting of the mounting position can be performed without mistakes.

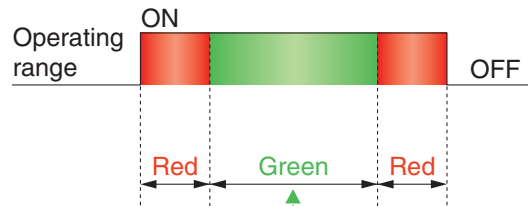

A **green** light illuminates up at the optimum operating range.

Optimum operating range

Even if 2-colour indication solid state auto switches are fixed at the optimum operating range (the green light illuminates up), the operation may become unstable depending on the installation environment or magnetic field disturbance. (Magnetic body, external magnetic field, proximal installation of cylinders with built-in magnet and actuators, temperature change, other factors for magnetic force fluctuation during operation, etc.)

For general environments

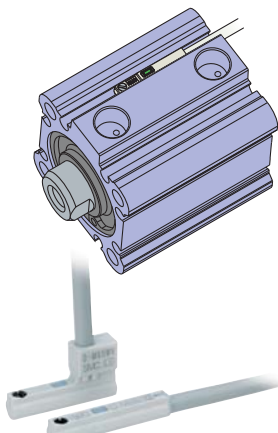

D-M9□W(V)

Water resistant type

For environments exposed to water and coolant

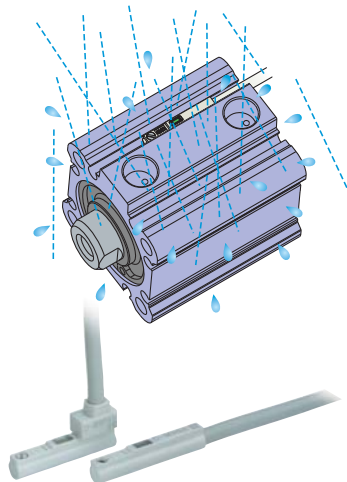

D-M9□A(V)

Magnetic field resistant type

For use with AC spot welders, which generate strong magnetic field

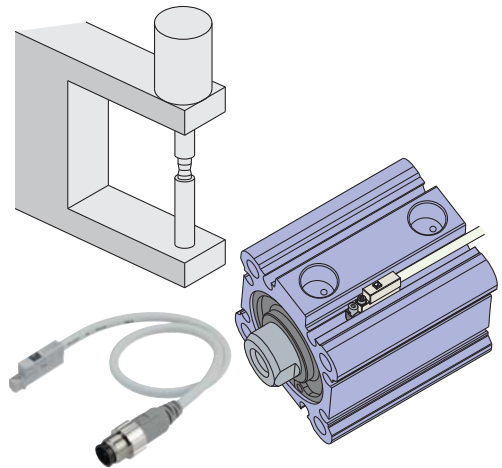

D-P3DW

Reduction
in labour
for work

- Reduction in number of components **NEW**
- No loss of components

1 Insert the auto switch.

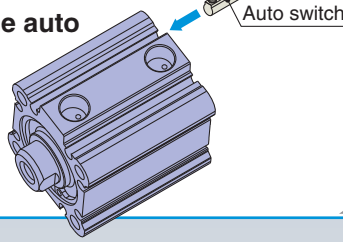

2 Fix the auto switch.

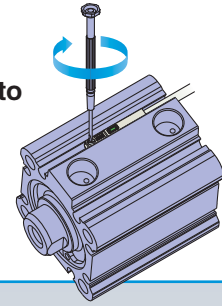

- Takes more labour and time because there are many components. **Existing model**
- It is likely to lose components

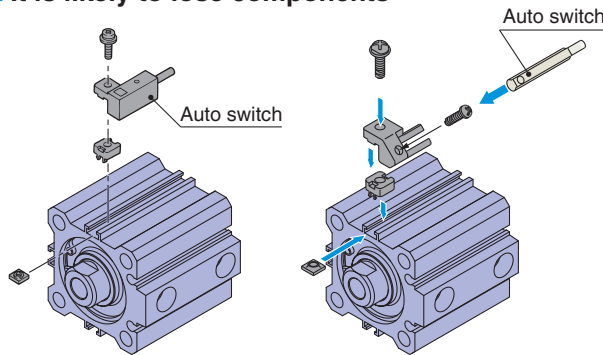

The nuts and screws may fall out when installed vertically.

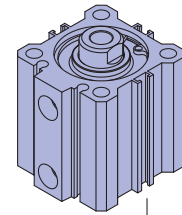

The nut falls out!

- The auto switch can be replaced with the foot brackets mounted. **NEW**

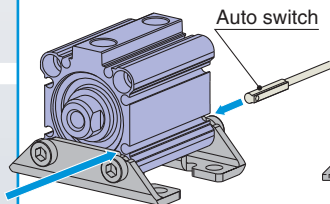

The bracket does not interfere with the slot.

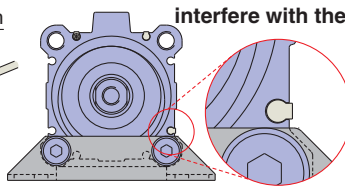

Existing model

The bracket interferes with the slot.

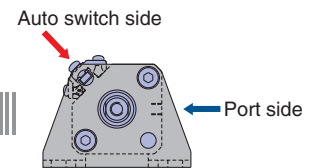
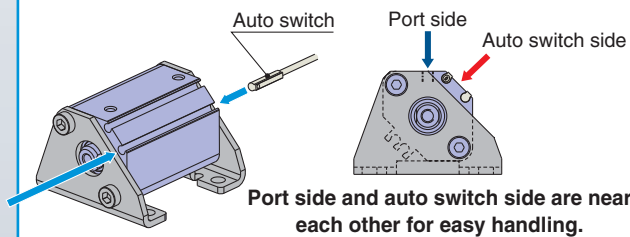
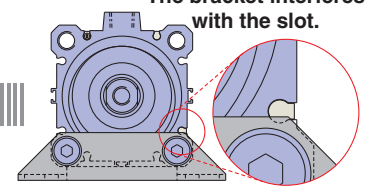

● The rail mounting type auto switch can be mounted.

Refer to page 174 for further information on auto switch mounting bracket.

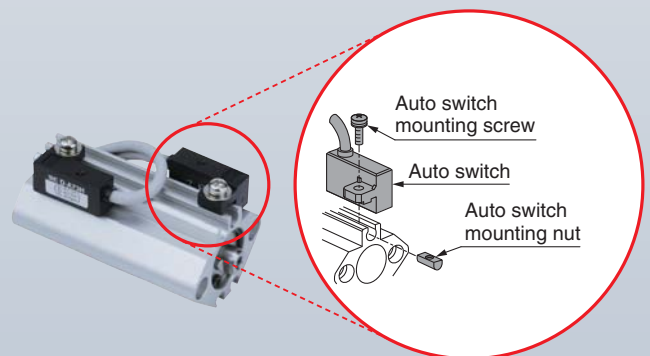
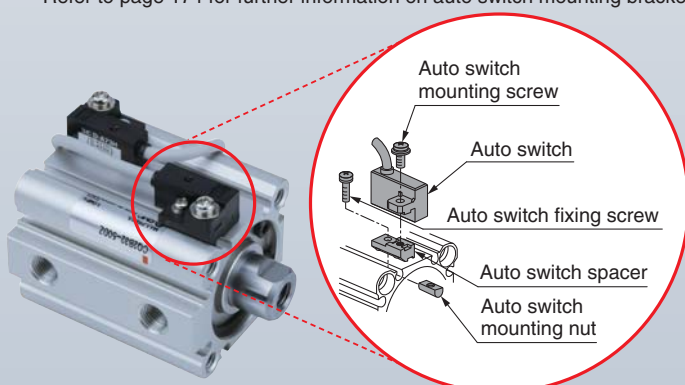

**Reduction
in labor
for order**

Part numbers with rod end bracket and/or mounting bolt

This reduces the steps to order the cylinder, rod end bracket, and mounting bolt separately.

Applicable cylinders: C(D)Q2, C(D)Q2□□□□-□S/-□T (Single acting)

Example) **CDQ2B32-30DMZ- L W -M9BW**

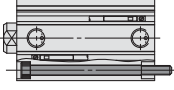
Mounting bolt	
Nil	No mounting bolt
L	Mounting bolt is shipped together. 

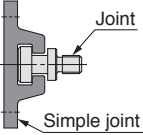
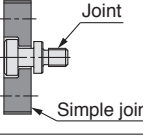
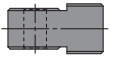
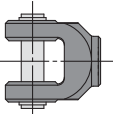
Rod end bracket	
Nil	No bracket and bolt
D	Simple joint A type + Joint 
E	Simple joint B type + Joint 
V	Single knuckle joint 
W	Double knuckle joint 

Ordering Example of Cylinder Assembly

Cylinder model: **CDQ2B32-30DMZ-LW-M9BW**

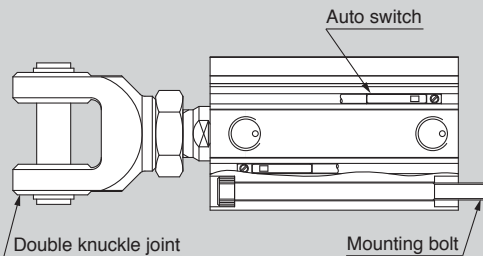

Mounting bracket **B** : Through-hole (Standard)
 Mounting bolt **L** : Yes
 Rod end bracket **W** : Double knuckle joint
 Auto switch D-M9BW : 2 pcs.

* Mounting bolt, single knuckle joint and auto switch are shipped together with the product.

Reduction of installation space

Added compact type foot brackets.

- Compact foot bracket has the same width as the cylinder
- Overall width reduced by up to **43%** (for $\phi 12$)

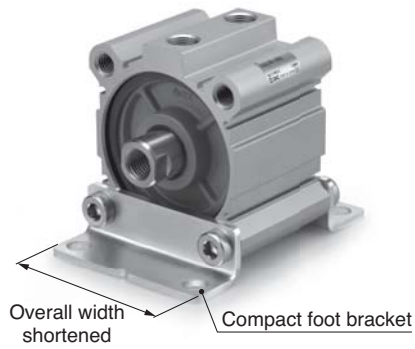

■ More compact installation space possible

- Short pitch mounting is possible.
- Allows installation close against a wall.

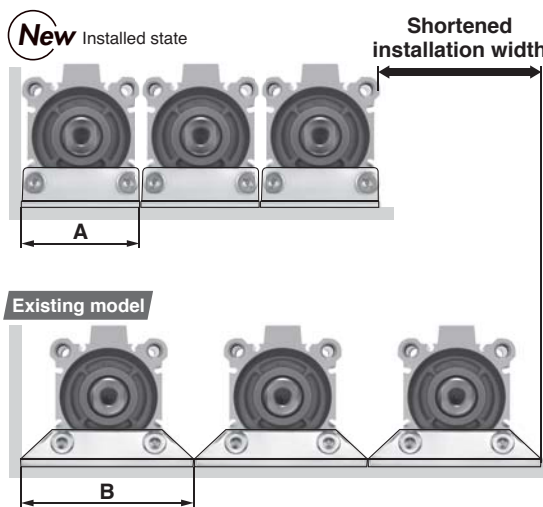

Bore size [mm]	New Compact foot type width A [mm]	Existing foot type width B [mm]	Reduced width for short pitch mounting [mm]		
			1 unit	2 units	3 units
12	25	44	19	38	57
16	29	48	19	38	57
20	36	62	26	52	78
25	40	66	26	52	78
32	45	71	26	52	78
40	52	78	26	52	78
50	64	95	31	62	93
63	77	113	36	72	108
80	98	140	42	84	126
100	117	162	45	90	135

* Short pitch mounting is possible only without auto switch.
Consult with SMC for mounting with auto switch.

- Small auto switch can be mounted with compact foot brackets attached.



- Height from the bottom of brackets to the centre of a cylinder is the same as the existing model.

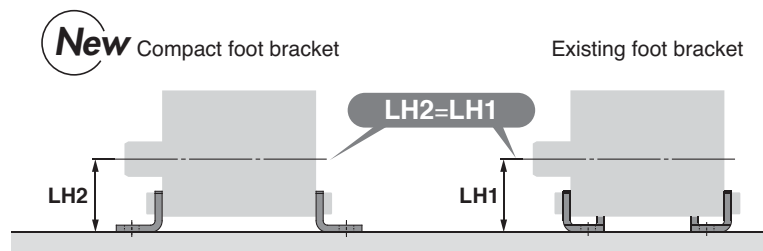

Applicable cylinders: C(D)Q2, C(D)Q2W, C(D)Q2 (Single acting) (Spring return/Spring extend), C(D)Q2K, C(D)Q2KW (Non-rotating), C(D)Q2 (Long stroke), C(D)Q2□S (Anti-lateral load), C(D)BQ2 (End lock), C(D)Q2□R/□V (Water resistant)

Reduction
in labour
for design

Added pivot brackets for double clevis.

■ Rotating angle: Max. **100°**
(For $\phi 12$, $\phi 16$)



- Time to design rotating bracket saved.
- Improved amount of mounting freedom
- Can be mounted to an installed double clevis cylinder.

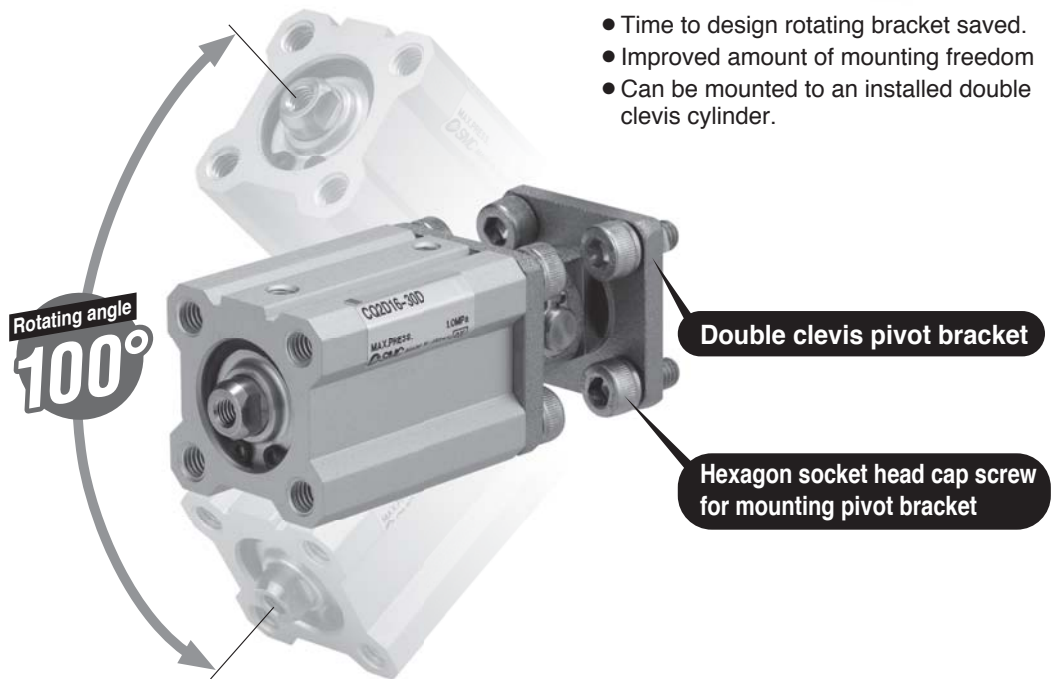







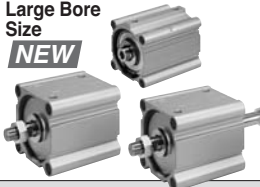

Applicable cylinders: CQ2 (Bore size $\phi 12$ to $\phi 100$, Mounting bracket, Applicable only to double clevis.)

Compact Cylinder *Series CQ2*

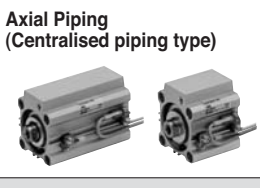
ø12, ø16, ø20, ø25, ø32, ø40, ø50, ø63, ø80, ø100, ø125, ø140, ø160, ø180, ø200

With a short overall length, the space-saving cylinder helps to make various jigs and equipment more compact.

Series Variations

Series	Action	Type	Bore size (mm)	Standard stroke (mm)	Page
Standard 	Double acting	Single rod CQ2	● 12 ● 16 ● 20 ● 25 ● 32 ● 40 ● 50 ● 63 ● 80 ● 100	ø12, ø16: 5 to 30 ø20, ø25: 5 to 50 ø32, ø40: 5 to 100 ø50 to ø100: 10 to 100	1
		Double rod CQ2W	● 12 ● 16 ● 20 ● 25 ● 32 ● 40 ● 50 ● 63 ● 80 ● 100	ø12, ø16: 5 to 30 ø20, ø25: 5 to 50 ø32, ø40: 5 to 100 ø50 to ø100: 10 to 100	26
	Single acting	Spring return/ Spring extend CQ2	● 12 ● 16 ● 20 ● 25 ● 32 ● 40 ● 50	ø12 to ø40: 5, 10 ø50: 10, 20	46
Large Bore Size 	Double acting	Single rod CQ2	● 125 ● 140 ● 160 ● 180 ● 200	10 to 300	71
		Double rod CQ2W	● 125 ● 140 ● 160 ● 180 ● 200	10 to 300	77
Long Stroke 	Double acting	Single rod CQ2	● 125 ● 140 ● 160 ● 180 ● 200	125 to 300	83
Non-rotating Rod 	Double acting	Single rod CQ2K	● 12 ● 16 ● 20 ● 25 ● 32 ● 40 ● 50 ● 63 ● 80 ● 100	ø12, ø16: 5 to 30 ø20, ø25: 5 to 50 ø32, ø40: 5 to 100 ø50, ø63: 10 to 100	94
		Double rod CQ2KW	● 12 ● 16 ● 20 ● 25 ● 32 ● 40 ● 50 ● 63 ● 80 ● 100	ø12, ø16: 5 to 30 ø20, ø25: 5 to 50 ø32, ø40: 5 to 100 ø50, ø63: 10 to 100	108
Axial Piping (Centralised piping type) 	Double acting	Single rod CQP2	● 12 ● 16 ● 20 ● 25 ● 32 ● 40 ● 50 ● 63 ● 80 ● 100	ø12, ø16: 5 to 30 ø20, ø25: 5 to 50 ø32, ø40: 5 to 100 ø50 to ø100: 10 to 100	121
	Single acting	Spring return/ Spring extend CQP2	● 12 ● 16 ● 20 ● 25 ● 32 ● 40 ● 50	ø12 to ø40: 5, 10 ø50: 10, 20	130
Anti-lateral Load 	Double acting	Single rod CQ2□S	● 32 ● 40 ● 50 ● 63 ● 80 ● 100	ø32 to ø40: 5 to 100 ø50 to ø100: 10 to 100	146
With End Lock 	Double acting	Single rod CBQ2	● 20 ● 25 ● 32 ● 40 ● 50 ● 63 ● 80 ● 100	ø20 to ø63: 10 to 100 ø80, ø100: 25 to 100	160
Water Resistant 	Double acting	Single rod CQ2□R	● 20 ● 25 ● 32 ● 40 ● 50 ● 63 ● 80 ● 100	ø20, ø25: 5 to 50 ø32, ø40: 5 to 100 ø50 to ø100: 10 to 100	178
Smooth Cylinder (Low friction) CQ2Y 	Refer to Best Pneumatics No. 3.				
Low-speed Cylinder CQ2X 	Refer to Best Pneumatics No. 3.				

Standard

Large Bore Size

Long Stroke

Non-rotating Rod

Axial Piping

Anti-lateral Load

With End Lock

Water Resistant

With Auto Switch

Auto Switch

Made to Order

Combinations of Standard Products and Made

Series CQ2

● : Standard
◎ : Made to Order
○ : Special product (For details, please contact SMC.)
— : Not available

Made to Order: For details, refer to pages 201 to 235.

Symbol	Specifications	Applicable bore size	CQ2 (Standard)				CQ2 (Large Bore Size)	
			Double acting		Single acting		Double acting	
			Single rod	Double rod	Single rod/ Spring return	Single rod/ Spring extend	Single rod	Double rod
			ø12 to ø100	ø12 to ø50		ø125 to ø200		
Standard	Standard product	ø12 to ø100	●	●	●	●	●	●
D	Built-in magnet		●	●	●	●	●	●
CQ2□A	Both ends tapped		●	●	●	●	●	●
CQ2□-□M	Rod end male thread		●	●	●	●	●	●
CQ2□-□C	With rubber bumper		●	●	○	○	● Note 2)	● Note 2)
CQ2□-□F	With boss on head end		●	—	●	●	○	—
CQ2□F	With one-touch fittings	ø32 to ø63	●	●	●	●	○	○
CQ2 ^L _F	Foot/Flange	ø12 to ø100	●	●	●	●	○	○
CQ2D	Double clevis		●	—	●	●	○	—
CQ2□H	Air-hydro type	ø20 to ø100	●	●	—	—	○	○
10-, 11-	Clean series	ø12 to ø100	●	○	○	○	○	○
20-	Copper and fluorine-free series		●	●	●	●	○	○
CQ2□ ^R	Water resistant	ø20 to ø100	●	● Note 6)	○	○	○	○
CQ2□M	Cylinder with Stable Lubrication Function (Lube-retainer) ^{Note 13)}	ø32 to ø100	●	○	○	○	—	—
XB6	Heat resistant cylinder (-10 to 150°C)	ø12 to ø100	◎	◎	○	○	○	○
XB7	Cold resistant cylinder (-40 to 70°C)	ø12 to ø40	◎	◎	○	○	○	○
XB9	Low-speed cylinder (10 to 50 mm/s)	ø12 to ø100	◎	◎	○	○	○	○
XB10	Intermediate stroke (Exclusive body type)	ø12 to ø200	◎	◎	◎	◎	◎	◎
XB10A	Intermediate stroke (Spacer-installed type)	ø32 to ø100	◎	○	○	○	○	○
XB11	Long stroke (Air-hydro type only)	ø20 to ø100	◎	—	—	—	—	—
XB13	Low-speed cylinder (5 to 50 mm/s)	ø12 to ø100	◎	◎	○	○	○	○
XB14 ^{Note 12)}	Cylinder with heat resistant auto switch	ø16 to ø63	◎	○	○	○	○	○
XC4	With heavy-duty scraper	ø20 to ø100	◎	◎ Note 6)	○	○	○	○
XC6	Piston rod/Retaining ring/Rod end nut material: Stainless steel	ø12 to ø100	◎	◎	◎	◎	○	○
XC8	Adjustable stroke cylinder/Adjustable extension type		◎	—	○	○	○	—
XC9	Adjustable stroke cylinder/Adjustable retraction type		◎	—	○	○	○	—
XC10	Dual stroke cylinder/Double rod		◎	—	○	○	○	—
XC11	Dual stroke cylinder/Single rod		◎	—	○	○	○	—
XC26	With split pins for double clevis pin/ double knuckle joint pin and flat washers		◎	—	◎	◎	○	○
XC27	Double clevis pin/Double knuckle joint pin material: Stainless steel 304	◎	○	◎	◎	○	○	
XC35	With coil scraper	ø32 to ø100	◎	◎	○	○	○	○
XC36	With boss on rod side	ø12 to ø100	◎	◎	◎	◎	○	○
X144	Special port location	ø12 to ø25	◎	◎	◎	◎	—	—
X202	Full length dimension is the same as Series CQ1.	ø12 to ø100	◎	—	◎	◎	—	—
X203	L dimension from rod cover is the same as Series CQ1.	ø12 to ø32	◎	—	◎	◎	—	—
X235	Special rod end for double rod cylinder	ø12 to ø200	—	◎	—	—	—	◎
X271	Fluororubber seals	ø12 to ø160	◎	◎	◎	◎	◎ Note 11)	◎ Note 11)
X293	Full length dimension is the same as Series CQ1W.	ø12 to ø100	—	◎	—	—	—	—
X525	Long stroke of adjustable extension stroke cylinder (-XC8)		◎	—	○	○	○	—
X526	Long stroke of adjustable retraction stroke cylinder (-XC9)		◎	—	○	○	○	—
X633	Intermediate stroke of double rod cylinder	ø12 to ø200	—	◎	—	—	—	◎
X636	Long stroke of dual stroke single rod cylinder	ø12 to ø100	◎	—	○	—	○	—
X1876	Cylinder tube: With concave boss on head side	ø20 to ø100	◎	—	◎	◎	—	—

Note 1) ø12 with auto switch: With rubber bumper (Standard)

Note 2) With rubber bumper (Standard)

Note 3) ø12 to ø16: (○), for ø20 to ø100 only (up to ø50 for single acting type)

Note 4) ø12 to ø32: (○), for ø40 to ø63 only

Note 5) ø12: (—)

Note 6) ø20 to ø32: (○), for ø40 to ø100 only

to Order Specifications

Series **CQ2**

	CQ2 (Long Stroke)	CQ2K (Non-rotating Rod)		CQP2 (Axial Piping) <small>Note 12)</small>			CQ2□S (Anti-lateral Load)	CBQ2 <small>Note 12)</small> (With End Lock)
	Double acting	Double acting		Double acting	Single acting		Double acting	Double acting
	Single rod	Single rod	Double rod	Single rod	Single rod/ Spring return	Single rod/ Spring extend	Single rod	Single rod
	ø32 to ø100	ø12 to ø63		ø12 to ø100	ø12 to ø50		ø32 to ø100	ø20 to ø100
	●	●	●	●	●	●	●	●
	●	●	●	●	●	●	●	●
	●	● Note 4)	● Note 4)	○	○	○	●	●
	●	●	●	●	●	●	●	●
	● Note 2)	○ Note 1)	○ Note 1)	●	○	○	● Note 2)	● Note 2)
	○	●	—	● Note 3)	● Note 3)	● Note 3)	●	○
	●	●	●	○	○	○	●	○
	●	● Note 4)	● Note 4)	○	○	○	●	●
	●	● Note 4)	—	○	○	○	●	●
	○	—	—	●	—	—	○	—
	○	○	○	○	○	○	○	○
	●	● Note 5)	● Note 5)	●	●	●	●	○
	○	—	—	● Note 7)	○	○	○	○
	○	—	—	○	○	○	○	○
	○	○	○	◎	○	○	○	○
	○	○	○	◎	○	○	○	—
	◎	◎ Note 4)	◎ Note 4)	○	○	○	◎	○
	○	○	○	○	○	○	○	○
	○	○	○	◎	○	○	○	○
	◎	—	—	◎ Note 7)	○	○	○	○
	◎	○	○	◎	◎	◎	◎	○
	○	◎	—	○	○	○	○	○ Note 8)
	○	◎	—	○	○	○	○	○ Note 9)
	○	◎	—	○	○	○	○	○
	○	◎	—	○	○	○	○	○
	◎	◎ Note 4)	—	○	○	○	◎	◎
	◎	◎	○	○	○	○	◎	○
	○	—	—	◎	○	○	○	○
	◎ Note 10)	◎ Note 10)	◎ Note 10)	◎	◎	◎	○	○
	—	○	○	—	—	—	—	—
	—	—	—	—	—	—	—	—
	—	—	○	—	—	—	—	—
	◎	○	○	◎	◎	◎	◎	○
	—	—	—	—	—	—	—	—
	○	○	—	○	○	○	○	○ Note 8)
	○	○	—	○	○	○	○	○ Note 9)
	—	—	◎	—	—	—	—	—
	○	○	—	○	○	—	○	○
	—	◎	—	—	—	◎	◎	○

Note 7) ø20 to ø25: (○), for ø32 to ø100 only
 Note 8) Rod end lock: (—), for head end lock only
 Note 9) Head end lock: (—), for rod end lock only

Note 10) With boss on rod end (Standard)
 Note 11) ø180 to ø200: (○), for ø125 to ø160 only
 Note 12) The body shape is the same as the existing product.
 Note 13) Only the products with an auto switch and without rubber bumper are compatible.

Standard
 Large Bore Size
 Long Stroke
 Non-rotating Rod
 Axial Piping
 Anti-lateral Load
 With End Lock
 Water Resistant
 With Auto Switch
 Auto Switch
 Made to Order



Compact Cylinder: Standard Double Acting, Single Rod

Series CQ2

ø12, ø16, ø20, ø25, ø32, ø40, ø50, ø63, ø80, ø100

How to Order

Without auto switch 12 to ø25

CQ2 **B** - **D** - -

Without auto switch ø32 to ø100

CQ2 **B** - **D** **Z** - -

With auto switch

CDQ2 **B** - **D** **Z** - **L** **W** - **M9BW** -

Mounting

B	Through-hole (Standard)	F	Rod flange
A	Both ends tapped	G	Head flange
L	Foot	D	Double clevis
LC	Compact foot		

* Mounting brackets are shipped together, (but not assembled).

Type

-	Pneumatic
H	Air-hydro <small>Note 1)</small>

Note 1) Bore sizes available for air-hydro type are ø20 to ø100.

Bore size

12	12 mm
16	16 mm
20	20 mm
25	25 mm
32	32 mm
40	40 mm
50	50 mm
63	63 mm
80	80 mm
100	100 mm

Port thread type

-	M thread	ø12 to ø25
	Rc	
TN	NPT	ø32 to ø100
TF	G	
F	Built-in one-touch fittings <small>Note 2)</small>	

Note 2) Bore sizes available with one-touch fittings are ø32 to ø63. Besides, it is not possible to use for air-hydro type.

Note 3) "TF" is not available for air-hydro type.

* For cylinders without auto switch, M threads are compatible only for ø32-5 mm stroke.

Mounting bolt

-	None
L	Shipped together

* Mounting bolt is shipped together only when the mounting bracket is "B".
* For details about the mounting bolt sizes, refer to pages 5 and 10.
* Mounting bolt is shipped together.

Auto switch mounting groove

Z	ø12 to ø25	2 surfaces
	ø32 to ø100	4 surfaces

Note 5) The made-to-order, heat resistant auto switch -XB14 is not applicable.

Auto switch

-	Without auto switch
---	---------------------

* Refer to the below table for applicable auto switches.

Number of auto switches

-	2 pcs.
S	1 pc.
n	"n" pcs.

Made to Order

Refer to the next page for details.

Body option

-	Standard (Rod end female thread)
F	With boss on head end
C	With rubber bumper <small>Note 4)</small>
M	Rod end male thread

* Combination of body options ("CM", "FC", "FM", "FCM") is available.
Note 4) Air-hydro type with rubber bumper is not available.

Auto switch

Z	ø12 to ø25	2 surfaces
	ø32 to ø100	4 surfaces

Note 5) The made-to-order, heat resistant auto switch -XB14 is not applicable.

Body option

-	Standard (Rod end female thread)
F	With boss on head end
C	With rubber bumper <small>Note 4)</small>
M	Rod end male thread

* Combination of body options ("CM", "FC", "FM", "FCM") is available.
Note 4) Air-hydro type with rubber bumper is not available.

Auto switch

-	Without auto switch
---	---------------------

* Refer to the below table for applicable auto switches.

Number of auto switches

-	2 pcs.
S	1 pc.
n	"n" pcs.

Made to Order

Refer to the next page for details.

Rod end bracket

(Refer to pages 19 and 20.)

-	None
D	Simple joint A type + Joint
E	Simple joint B type + Joint
V	Single knuckle joint
W	Double knuckle joint

* The single knuckle joint and double knuckle joint cannot be mounted for the rod end female thread.
* A knuckle joint pin is not provided with the single knuckle joint.
* The simple joint A and B types cannot be mounted for the rod end male thread.
* Rod end bracket is shipped together.

Action

D	Double acting
----------	---------------

Cylinder stroke (mm)

Refer to the next page and page 3 for standard strokes and intermediate strokes.

Built-in Magnet Cylinder Model

If a built-in magnet cylinder without an auto switch is required, there is no need to enter the symbol for the auto switch.
(Example) CDQ2L32-25DZ

Refer to pages 1263 to 1371 in Best Pneumatics No. 2 for further information on auto switches.
Refer to the individual catalogue (ES20-201) for the D-P3DW type.

Applicable Auto Switches

Type	Special function	Electrical entry	Indicator light	Wiring (Output)	Load voltage		Auto switch model		Lead wire length (m)					Pre-wired connector	Applicable load		
					DC	AC	Perpendicular	In-line	0.5 (-)	1 (M)	3 (L)	5 (Z)	None (N)				
Solid state auto switch	—	Grommet	Yes	3-wire (NPN)	24 V	5 V, 12 V	—	M9NV	M9N	●	●	●	○	—	○	IC circuit	
				3-wire (PNP)				M9PV	M9P	●	●	●	○	—	○		
				2-wire				M9BV	M9B	●	●	●	○	—	○		
				3-wire (NPN)				M9NWV	M9NW	●	●	●	○	—	○		
				3-wire (PNP)				M9PWV	M9PW	●	●	●	○	—	○		
				2-wire				M9BWV	M9BW	●	●	●	○	—	○		
	Water resistant (2-colour indication)	Grommet	Yes	3-wire (NPN)	24 V	5 V, 12 V	—	M9NAV**	M9NA**	○	○	●	○	—	○	IC circuit	
				3-wire (PNP)				M9PAV**	M9PA**	○	○	●	○	—	○		
				2-wire				M9BAV**	M9BA**	○	○	●	○	—	○		
				2-wire (Non-polar)				—	P3DW	●	—	●	●	—	○		
				3-wire (NPN equivalent)				—	A96V	A96	●	—	●	—	—		○
				2-wire				—	A93V	A93	●	—	●	—	—		○
Reed auto switch	—	Grommet	Yes	3-wire (NPN equivalent)	24 V	5 V, 12 V	100 V or less	A90V	A90	●	—	●	—	—	○	IC circuit	
				2-wire				A93V	A93	●	—	●	—	—	○		
				2-wire				A90V	A90	●	—	●	—	—	○		

* Water resistant type auto switches can be mounted on the above models, but in such case SMC cannot guarantee water resistance. If water resistance is needed, we recommend water resistant cylinders be used. (Page 178)

* Lead wire length symbols: 0.5 m — (Example) M9NW
1 m M (Example) M9NWM
3 m L (Example) M9NWL
5 m Z (Example) M9NWZ

* Solid state auto switches marked with "O" are produced upon receipt of order.
* The D-P3DW□ type is available from ø32 to ø100 only.

* There are other applicable auto switches other than the listed above. For details, refer to page 199.
* For details about auto switches with pre-wired connector, refer to pages 1328 and 1329 in Best Pneumatics No. 2.

Compact Cylinder: Standard Double Acting, Single Rod **Series CQ2**



Symbol

Double acting,
Single rod

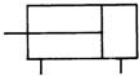

Symbol

With boss on
head end

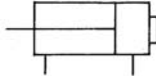

Made to Order

(For details, refer to pages 201 to 235.)

Symbol	Specifications
-XA□	Special rod end shape
-XB6	Heat resistant cylinder (-10 to 150°C) w/o auto switch only
-XB7	Cold resistant cylinder (-40 to 70°C) w/o auto switch only
-XB9	Low-speed cylinder (10 to 50 mm/s)
-XB10	Intermediate stroke (Exclusive body type)
-XB10A	Intermediate stroke (Spacer-installed type)
-XB11	Long stroke (Air-hydro type only)
-XB13	Low-speed cylinder (5 to 50 mm/s)
-XB14	Cylinder with heat resistant auto switch ø16 to ø63 only
-XC2(A)	Rod end length, 10mm increased (For foot and flange bracket)
-XC4	With heavy-duty scraper, ø20 to ø100 only
-XC6	Piston rod/Retaining ring/Rod end nut material: Stainless steel
-XC8	Adjustable stroke cylinder/Adjustable extension type
-XC9	Adjustable stroke cylinder/Adjustable retraction type
-XC10	Dual stroke cylinder/Double rod
-XC11	Dual stroke cylinder/Single rod
-XC26	With split pins for double clevis pin/ double knuckle joint pin and flat washers
-XC27	Double clevis pin/Double knuckle joint pin material: Stainless steel 304
-XC35	With coil scraper, ø32 to ø100 only
-XC36	With boss on rod side
-XC85	Grease for food processing equipment
-XC92	Dust resistant actuator
-X144	Special port location, with auto switch ø12 to ø25 only
-X202	Full length dimension is the same as Series CQ1, Except ø16, ø25.
-X203	L dimension from rod cover is the same as Series CQ1, ø20, ø32 only.
-X271	Fluororubber seals
-X525	Long stroke of adjustable extension stroke cylinder (-XC8)
-X526	Long stroke of adjustable retraction stroke cylinder (-XC9)
-X636	Long stroke of dual stroke single rod cylinder
-X1876	Cylinder tube: With concave boss on head side

Note) -XB14: The body shape is the same as the existing product.

Refer to pages 193 to 199 for the specifications of cylinders with autoswitches.

- Auto switch proper mounting position (detection at stroke end) and its mounting height
- Minimum stroke for auto switch mounting
- Operating range
- Auto switch mounting brackets/Part no.

Specifications

Pneumatic type

Bore size (mm)	12	16	20	25	32	40	50	63	80	100	
Action	Double acting, Single rod										
Fluid	Air										
Proof pressure	1.5 MPa										
Maximum operating pressure	1.0 MPa										
Minimum operating pressure	0.07 MPa		0.05 MPa								
Ambient and fluid temperature	Without auto switch: -10 to 70°C (No freezing) With auto switch: -10 to 60°C (No freezing)										
Lubrication	Not required (Non-lube)										
Piston speed	50 to 500 mm/s										
Allowable kinetic energy (J)	Standard	0.022	0.038	0.055	0.09	0.15	0.26	0.46	0.77	1.36	2.27
	With rubber bumper	0.043	0.075	0.11	0.18	0.29	0.52	0.91	1.54	2.71	4.54
Stroke length tolerance	+1.0 mm (Note) 0										

Note) Stroke length tolerance does not include the amount of bumper change.

Air-hydro type

Bore size (mm)	20	25	32	40	50	63	80	100
Action	Double acting, Single rod							
Fluid	Turbine oil (Note)							
Proof pressure	1.5 MPa							
Maximum operating pressure	1.0 MPa							
Minimum operating pressure	0.18 MPa				0.1 MPa			
Ambient and fluid temperature	5 to 60C							
Piston speed	5 to 50 mm/s							
Cushion	None							
Stroke length tolerance	+1.0 mm 0							

Note) Refer to "Handling Precautions for SMC Products" (M-E03-3) for Actuator Precautions (5).

Standard Strokes

Pneumatic type

Bore size	Standard stroke
12, 16	5, 10, 15, 20, 25, 30
20, 25	5, 10, 15, 20, 25, 30, 35, 40, 45, 50
32, 40	5, 10, 15, 20, 25, 30, 35, 40, 45, 50, 75, 100
50 to 100	10, 15, 20, 25, 30, 35, 40, 45, 50, 75, 100

- For long strokes exceeding the standard stroke range, refer to page 83.
- For intermediate strokes, refer to page 3.

Air-hydro type

Bore size	Standard stroke
20, 25	5, 10, 15, 20, 25, 30, 35, 40, 45, 50
32, 40	5, 10, 15, 20, 25, 30, 35, 40, 45, 50, 75, 100
50, 63, 80, 100	10, 15, 20, 25, 30, 35, 40, 45, 50, 75, 100

Mounting Brackets/Part No.

Bore size (mm)	Model	Foot (Note 1)	Compact Foot (Note 1)	Flange	Doubleclevis
12	Without switch	CQ2□□-□D	CQ-L012	CQ-LC012	CQ-F012 CQ-D012
	With switch	CQ2□□-□DZ	CQ-LZ12	CQ-LCZ12	
16	Without switch	CQ2□□-□D	CQ-L016	CQ-LC016	CQ-F016 CQ-D016
	With switch	CQ2□□-□DZ	CQ-LZ16	CQ-LCZ16	
20	Without switch	CQ2□□-□D	CQ-L020	CQ-LC020	CQ-F020 CQ-D020
	With switch	CQ2□□-□DZ	CQ-LZ20	CQ-LCZ20	
25	Without switch	CQ2□□-□D	CQ-L025	CQ-LC025	CQ-F025 CQ-D025
	With switch	CQ2□□-□DZ	CQ-LZ25	CQ-LCZ25	
32	CQ2□□-□DZ	CQ-L032	CQ-LC032	CQ-F032	CQ-D032
40	CQ2□□-□DZ	CQ-L040	CQ-LC040	CQ-F040	CQ-D040
50	CQ2□□-□DZ	CQ-L050	CQ-LC050	CQ-F050	CQ-D050
63	CQ2□□-□DZ	CQ-L063	CQ-LC063	CQ-F063	CQ-D063
80	CQ2□□-□DZ	CQ-L080	CQ-LC080	CQ-F080	CQ-D080
100	CQ2□□-□DZ	CQ-L100	CQ-LC100	CQ-F100	CQ-D100

Note 1) When ordering a foot and compact foot brackets, the required quantity will be different depending on the bore size.

- ø12 to ø25:
 - Without switch: Order 2 pieces per cylinder.
 - With switch: Order 1 piece per cylinder. (Part number for a set of 2 foot brackets)
- ø32 to ø100:
 - Order 2 pieces per cylinder.

Note 2) Parts belonging to each bracket are as follows.

- Foot, Compact foot, Flange: Body mounting bolts
- Double clevis: Clevis pin, Type C retaining rings for axis, Body mounting bolts

Manufacture of Intermediate Strokes (Except air-hydro type)

1. Spacer-installed type 1: Standard model number

Intermediate stroke with ○: Available in 1 mm intervals

A spacer is installed on tubes with a stroke longer than the specified stroke (◆).

◆: Standard stroke

Bore size (mm)	Stroke range	Type	Stroke																	
			5	10	15	20	25	30	35	40	45	50	75	100						
12, 16	1 to 29	Spacer-installed type 1	○	◆	○	◆	○	◆	○	◆	○	◆	○	◆	○	◆	○	◆		
20, 25	1 to 49		○	◆	○	◆	○	◆	○	◆	○	◆	○	◆	○	◆	○	◆		
32, 40	1 to 99		○	◆	○	◆	○	◆	○	◆	○	◆	○	◆	○	◆	○	◆		
50 to 100	1 to 99		○	◆	○	◆	○	◆	○	◆	○	◆	○	◆	○	◆	○	◆		

Ordering example (when ordering ø32-57 mm stroke (with through-hole (standard), without switch)

Type	1. Spacer-installed type 1
Part no.	Standard model number
Order no.	CQ2B32-57DZ (uses 75 mm stroke tube) • CQ2B32-75DZ with 18 mm width spacer inside • The B dimension is 108 mm.

2. Spacer-installed type 2: Suffix “-XB10A”

Intermediate stroke with ○: Available in 1 mm intervals

A spacer is installed on tubes with a stroke longer than the specified stroke (●).

◆: Standard stroke ●: Stroke in stock

Bore size (mm)	Stroke range	Type	Stroke													
			55	60	65	70	* 75	80	85	90	95	* 100				
32, 40	51 to 94	Spacer-installed type 2	○	●	○	●	○	●	○	●	○	●	○	●	○	●
50 to 100	51 to 94		○	●	○	●	○	●	○	●	○	●	○	●	○	●

Ordering example (when ordering ø32-57 mm stroke (with through-hole (standard), without switch)

Type	2. Spacer-installed type 2
Part no.	Suffix “-XB10A” to the end of model number.
Order no.	CQ2B32-57DZ-XB10A (uses 60 mm stroke tube) • CQ2B32-60DZ-XB10 with 3 mm width spacer inside • The B dimension is 93 mm.

Note) Specify a spacer-installed type 1 with standard model number for ordering an intermediate stroke with a * mark. Refer to page 211 for details.

3. Exclusive body type: Suffix “-XB10”

Available in 1 mm intervals

Exclusive body can be manufactured for specified stroke upon request.

Bore size (mm)	Stroke range	Type
12, 16	6 to 29	Exclusive body
20, 25	6 to 49	
32, 40	6 to 99	
50 to 100	11 to 99	

Note) In the case of exclusive body type with ø32 to ø100 (-XB10) with the stroke length exceeding 50 mm, reference values of the longitudinal dimension (A/B dimension) will be the same as those with auto switch. Refer to page 209 for details.

Ordering example

(when ordering ø32-57 mm stroke (with through-hole (standard), without switch)

Type	3. Exclusive body type
Part no.	Suffix “-XB10” to the end of model number.
Order no.	CQ2B32-57DZ-XB10 (uses 57 mm stroke tube) • Makes 57 mm stroke tube. • The B dimension is 90 mm.

For 55, 60, 65, 70, 80, 85, 90, and 95 stroke, exclusive bodies are kept in inventory, enabling shorter delivery times.

Retaining Ring Installation/Removal

⚠ Caution

- For installation and removal, use an appropriate pair of pliers (tool for installing a type C retaining ring).
- Even if a proper plier (tool for installing a type C retaining ring) is used, it is likely to inflict damage to a human body or peripheral equipment, as a retaining ring may be flown out of the tip of a plier (tool for installing a type C retaining ring). Be much careful with the popping of a retaining ring. Besides, be certain that a retaining ring is placed firmly into the groove of rod cover before supplying air at the time of installment.

Mounting

⚠ Caution

The CQ2 series compact cylinders are designed to create compact mechanical equipment and promote space saving. Thus, if it is used in the same manner as conventional cylinders such as tie-rod cylinders, it may degrade the performance. Paysufficientattention to the operating conditions when using.

Mounting

⚠ Caution

1. Allowable lateral load

Lateral load that can apply to the piston rod end is limited. If a cylinder is used with lateral load over the limit, it may cause air leakage due to abnormal friction of seals, galling of cylinder tubes and pistons, or abnormal friction of the bearing part. The lateral load applied to the piston rod must be within the allowable range indicated in this catalogue. When the load exceeds the limit, use a double rod cylinder, install a guide, or change the bore size to suit the load in order to make the load within the allowable range. As a standard product, an anti-lateral load type cylinder that is resistant to approx. 2 times more than the conventional compact CQ2 series is also available (page 146).

2. Connection with a work piece

When a work piece is mounted on the piston rod end, connect them aligning the center of piston rod and a work piece. If they are off-center, lateral load is generated and phenomena mentioned in (1) may occur. In order not to apply the off-center load, use of a floating joint or simple joint is recommended.

3. Simultaneous use of multiple cylinders

It is difficult to control the speed of pneumatic cylinders. The following conditions cause speed change: change in supply pressure, load, temperature and lubrication, performance difference of each cylinder, deterioration of each part over time, etc. As speed controller can be used to control the speed of multiple cylinders simultaneously for a short period of time, but depending on conditions, it may not work as desired. If multiple cylinders cannot operate simultaneously, unreasonable force is applied to the piston rod because cylinder positions may not be the same. This may cause abnormal friction of seals and bearings, and galling of cylinder tubes and pistons. Do not use an application to operate several cylinders simultaneously by adjusting cylinder speed. If this is inevitable, use a high rigid guide against load, so that the cylinder is not damaged even when the each cylinder output is slightly different.

Allowable Kinetic Energy

Load Weight and Piston Speed (J)

Bore size (mm)	12	16	20	25	32	40	50	63	80	100
Standard/ Allowable kinetic energy: Ea	0.022	0.038	0.055	0.09	0.15	0.26	0.46	0.77	1.36	2.27
With rubber bumper/ Allowable kinetic energy: Eb	0.043	0.075	0.110	0.18	0.29	0.52	0.91	1.54	2.71	4.54

$$\text{Kinetic energy } E \text{ (J)} = \frac{(m1+m2) V^2}{2}$$

m1: Weight of cylinder movable parts kg
m2: Load weight kg
V: Piston speed m/s

Weight of Cylinder Movable Parts/Without Built-in Magnet (g)

Bore size (mm)	Cylinder stroke (mm)											
	5	10	15	20	25	30	35	40	45	50	75	100
12	5	6	7	8	10	11	—	—	—	—	—	—
16	9	11	13	15	17	19	—	—	—	—	—	—
20	15	18	21	24	27	31	34	37	40	44	—	—
25	24	28	33	37	42	46	51	55	60	64	—	—
32	45	52	60	68	76	84	92	100	107	115	170	209
40	64	72	80	88	96	104	112	119	127	135	190	229
50	—	117	129	141	153	166	178	190	202	214	300	361
63	—	153	165	177	190	202	214	226	239	251	337	398
80	—	270	289	308	327	347	366	385	404	423	557	653
100	—	487	515	543	570	598	625	653	681	708	901	1038

Weight of Cylinder Movable Parts/With Built-in Magnet (g)

Bore size (mm)	Cylinder stroke (mm)											
	5	10	15	20	25	30	35	40	45	50	75	100
12	8	9	10	11	12	13	—	—	—	—	—	—
16	16	18	20	22	24	26	—	—	—	—	—	—
20	28	31	34	37	40	44	47	50	53	56	—	—
25	44	48	53	57	62	66	71	75	80	84	—	—
32	78	86	93	101	109	117	125	133	140	148	187	227
40	109	117	125	133	140	148	156	164	172	180	219	258
50	—	187	199	211	223	236	248	260	272	285	346	407
63	—	254	266	278	290	303	315	327	339	352	413	474
80	—	433	453	472	491	510	530	549	568	587	683	778
100	—	741	768	796	823	851	879	906	934	962	1099	1236

Additional Weight of Cylinder Movable Parts (g)

Bore size (mm)	Rod end male thread	12	16	20	25	32	40	50	63	80	100
		Male thread	1.5	3	6	12	26	27	53	53	120
	Nut	1	2	4	8	17	17	32	32	49	116
With rubber bumper		0	0	-2	-3	-3	-7	-9	-18	-31	-56

Calculation: (Example) **CDQ2B32-20DCMZ**

- Basic weight: CDQ2B32-20DZ..... 101 g
- Additional weight: Rod end male thread..... 43 g
- With rubber bumper..... -3 g
- 141 g

Allowable Lateral Load at Rod End

Without Auto Switch

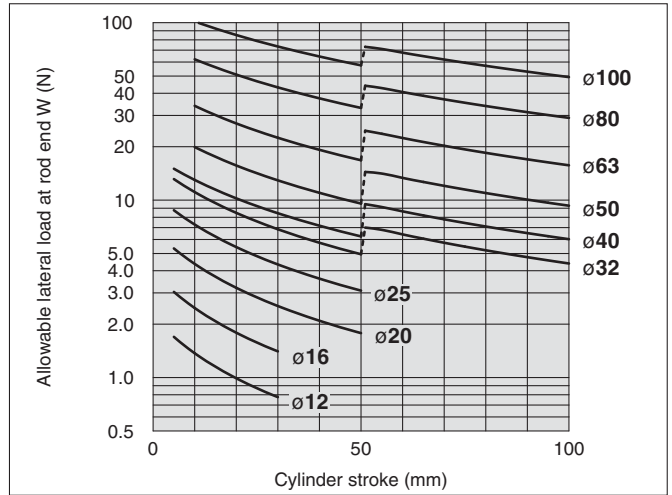

With Auto Switch

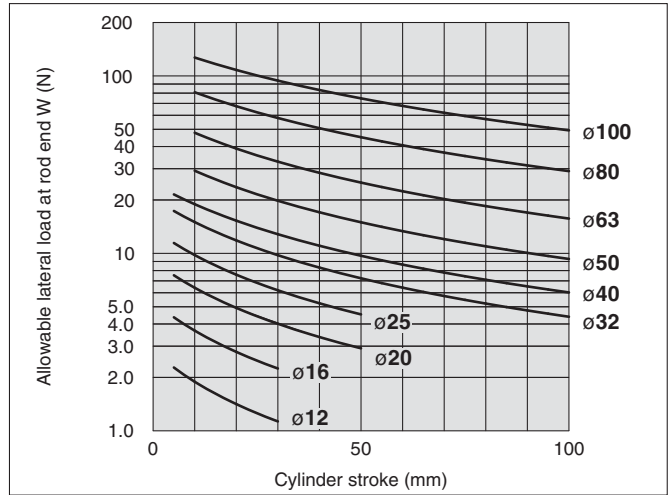

If an allowable lateral load at rod end is exceeding the value in the graph, we recommend anti-lateral load type cylinder be used.

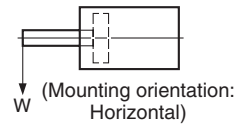

Theoretical Output

Bore size (mm)	Operating direction	Operating pressure (MPa)		
		0.3	0.5	0.7
12	IN	25	42	59
	OUT	34	57	79
16	IN	45	75	106
	OUT	60	101	141
20	IN	71	118	165
	OUT	94	157	220
25	IN	113	189	264
	OUT	147	245	344
32	IN	181	302	422
	OUT	241	402	563
40	IN	317	528	739
	OUT	377	628	880
50	IN	495	825	1150
	OUT	589	982	1370
63	IN	841	1400	1960
	OUT	935	1560	2180
80	IN	1360	2270	3170
	OUT	1510	2510	3520
100	IN	2140	3570	5000
	OUT	2360	3930	5500

- Standard
- Large Bore Size
- Long Stroke
- Non-rotating Rod
- Axial Piping
- Anti-lateral Load
- With End Lock
- Water Resistant
- With Auto Switch
- Auto Switch
- Made to Order

Series CQ2

Weight

Weight (g)

Bore size (mm)	Cylinder stroke (mm)											
	5	10	15	20	25	30	35	40	45	50	75	100
12	29	35	41	47	54	60	—	—	—	—	—	—
16	42	50	59	67	76	84	—	—	—	—	—	—
20	63	75	88	101	114	127	140	152	165	178	—	—
25	86	100	115	129	144	158	173	187	202	216	—	—
32	125	145	165	184	204	224	244	263	283	303	448	547
40	187	208	230	251	273	294	315	337	358	380	552	664
50	—	339	372	405	438	471	504	537	570	603	872	1043
63	—	480	518	556	594	632	670	708	746	784	1112	1308
80	—	916	976	1036	1097	1157	1217	1277	1338	1398	1917	2215
100	—	1608	1688	1768	1849	1929	2010	2090	2170	2251	2982	3391

Mounting Bolt for CQ2B/Without Auto Switch

Mounting method: Mounting bolt for through-hole mounting of the CQ2B is available as an option. Refer to the following for ordering procedures. Order the actual number of bolts that will be used.

Example) CQ-M3 x 25L 4 pcs.

Material: Chromium molybdenum steel
Surface treatment: Zinc chromated

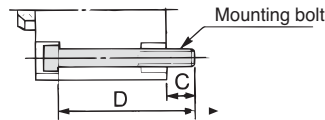

Cylinder model	C	D	Mounting bolt part no.
CQ2B12-5D	6.5	25	CQ-M3 x 25L
-10D		30	x 30L
-15D		35	x 35L
-20D		40	x 40L
-25D		45	x 45L
-30D		50	x 50L
CQ2B16-5D	5	25	CQ-M3 x 25L
-10D		30	x 30L
-15D		35	x 35L
-20D		40	x 40L
-25D		45	x 45L
-30D		50	x 50L
CQ2B20-5D	7.5	25	CQ-M5 x 25L
-10D		30	x 30L
-15D		35	x 35L
-20D		40	x 40L
-25D		45	x 45L
-30D		50	x 50L
-35D		55	x 55L
-40D		60	x 60L
-45D		65	x 65L
-50D		70	x 70L
CQ2B25-5D	9.5	30	CQ-M5 x 30L
-10D		35	x 35L
-15D		40	x 40L
-20D		45	x 45L
-25D		50	x 50L
-30D		55	x 55L
-35D		60	x 60L
-40D		65	x 65L
-45D		70	x 70L
-50D		75	x 75L
CQ2B32-5DZ	9	30	CQ-M5 x 30L
-10DZ		35	x 35L
-15DZ		40	x 40L
-20DZ		45	x 45L
-25DZ		50	x 50L
-30DZ		55	x 55L
-35DZ		60	x 60L
-40DZ		65	x 65L
-45DZ		70	x 70L
-50DZ		75	x 75L
-55DZ-XB10		90	x 90L
-60DZ-XB10		95	x 95L
-65DZ-XB10		100	x 100L
-70DZ-XB10		105	x 105L
-75DZ		110	x 110L
-80DZ-XB10		115	x 115L
-85DZ-XB10	120	x 120L	
-90DZ-XB10	125	x 125L	
-95DZ-XB10	130	x 130L	
-100DZ	135	x 135L	

Cylinder model	C	D	Mounting bolt part no.
CQ2B40-5DZ	7.5	35	CQ-M5 x 35L
-10DZ		40	x 40L
-15DZ		45	x 45L
-20DZ		50	x 50L
-25DZ		55	x 55L
-30DZ		60	x 60L
-35DZ		65	x 65L
-40DZ		70	x 70L
-45DZ		75	x 75L
-50DZ		80	x 80L
-55DZ-XB10	95	x 95L	
-60DZ-XB10	100	x 100L	
-65DZ-XB10	105	x 105L	
-70DZ-XB10	110	x 110L	
-75DZ	115	x 115L	
-80DZ-XB10	120	x 120L	
-85DZ-XB10	125	x 125L	
-90DZ-XB10	130	x 130L	
-95DZ-XB10	135	x 135L	
-100DZ	140	x 140L	
CQ2B50-10DZ	12.5	45	CQ-M6 x 45L
-15DZ		50	x 50L
-20DZ		55	x 55L
-25DZ		60	x 60L
-30DZ		65	x 65L
-35DZ		70	x 70L
-40DZ		75	x 75L
-45DZ		80	x 80L
-50DZ		85	x 85L
-55DZ-XB10		100	x 100L
-60DZ-XB10	105	x 105L	
-65DZ-XB10	110	x 110L	
-70DZ-XB10	115	x 115L	
-75DZ	120	x 120L	
-80DZ-XB10	125	x 125L	
-85DZ-XB10	130	x 130L	
-90DZ-XB10	135	x 135L	
-95DZ-XB10	140	x 140L	
-100DZ	145	x 145L	
CQ2B63-10DZ	14.5	50	CQ-M8 x 50L
-15DZ		55	x 55L
-20DZ		60	x 60L
-25DZ		65	x 65L
-30DZ		70	x 70L
-35DZ		75	x 75L
-40DZ		80	x 80L
-45DZ		85	x 85L
-50DZ		90	x 90L
-55DZ-XB10		105	x 105L
-60DZ-XB10		110	x 110L
-65DZ-XB10		115	x 115L
-70DZ-XB10		120	x 120L
-75DZ		125	x 125L
-80DZ-XB10		130	x 130L
-85DZ-XB10		135	x 135L
-90DZ-XB10	140	x 140L	
-95DZ-XB10	145	x 145L	
-100DZ	150	x 150L	

Cylinder model	C	D	Mounting bolt part no.
CQ2B80-10DZ	15	55	CQ-M10 x 55L
-15DZ		60	x 60L
-20DZ		65	x 65L
-25DZ		70	x 70L
-30DZ		75	x 75L
-35DZ		80	x 80L
-40DZ		85	x 85L
-45DZ		90	x 90L
-50DZ		95	x 95L
-55DZ-XB10		110	x 110L
-60DZ-XB10	115	x 115L	
-65DZ-XB10	120	x 120L	
-70DZ-XB10	125	x 125L	
-75DZ	130	x 130L	
-80DZ-XB10	135	x 135L	
-85DZ-XB10	140	x 140L	
-90DZ-XB10	145	x 145L	
-95DZ-XB10	150	x 150L	
-100DZ	155	x 155L	
CQ2B100-10DZ	15.5	65	CQ-M10 x 65L
-15DZ		70	x 70L
-20DZ		75	x 75L
-25DZ		80	x 80L
-30DZ		85	x 85L
-35DZ		90	x 90L
-40DZ		95	x 95L
-45DZ		100	x 100L
-50DZ		105	x 105L
-55DZ-XB10		120	x 120L
-60DZ-XB10		125	x 125L
-65DZ-XB10		130	x 130L
-70DZ-XB10		135	x 135L
-75DZ		140	x 140L
-80DZ-XB10		145	x 145L
-85DZ-XB10		150	x 150L
-90DZ-XB10	155	x 155L	
-95DZ-XB10	160	x 160L	
-100DZ	165	x 165L	

Additional Weight (g)

Bore size (mm)	12	16	20	25	32	40	50	63	80	100
Both ends tapped	2	2	6	6	6	6	6	19	45	45
Rod end male thread	1	2	4	8	17	17	32	49	116	175
Nut										
With boss on head end	0.7	1.3	2	3	5	7	13	25	45	96
With rubber bumper	0	0	-2	-3	-3	-7	-9	-18	-31	-56
Built-in one-touch fittings	—	—	—	—	12	12	21	21	—	—
Foot (Including mounting bolts)	55	67	164	186	142	154	243	317	683	1052
Compact foot (Including mounting bolts)	41	51	121	140	99	114	177	241	501	770
Rod flange (Including mounting bolts)	57	69	139	161	180	214	373	559	1056	1365
Head flange (Including mounting bolts)	54	65	133	152	165	198	348	534	1017	1309
Double clevis (Including pin, retaining rings, bolts)	32	39	88	123	151	196	393	554	1109	1887

Calculation: (Example) CQ2D32-20DCMZ

- Basic weight: CQ2B32-20DZ 184 g
 - Additional weight: Both ends tapped 6 g
 - Rod end male thread 43 g
 - With rubber bumper -3 g
 - Double clevis 151 g
- 381 g

Construction

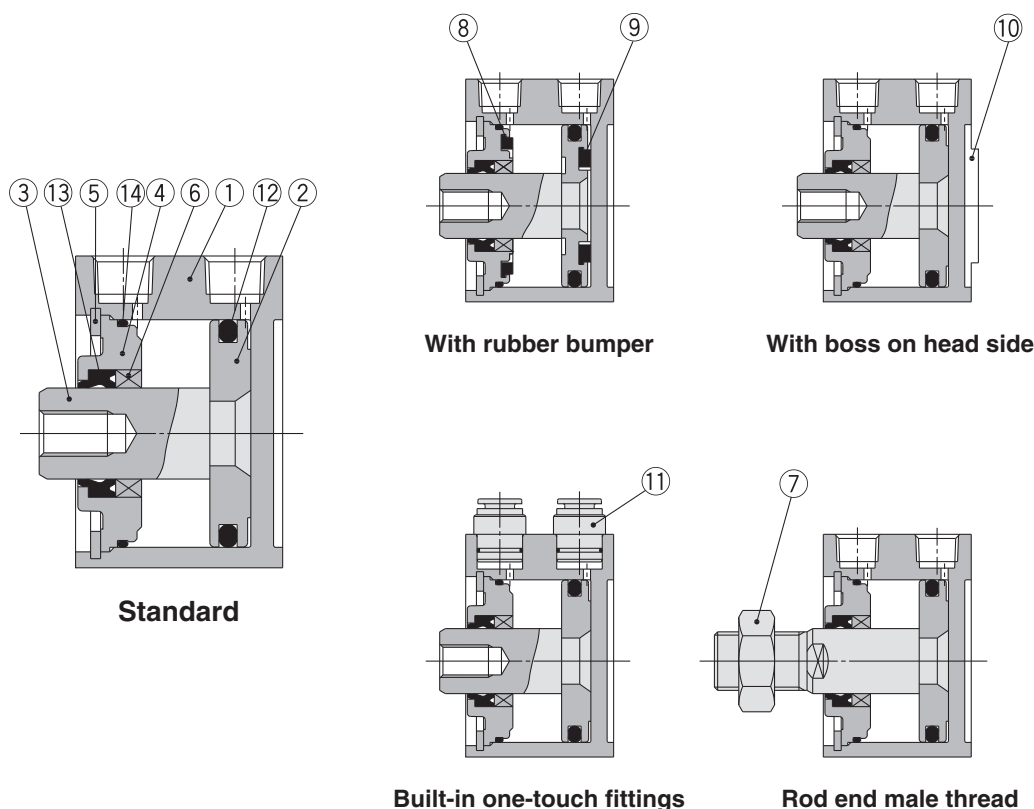

Component Parts

No.	Description	Material	Note
1	Cylinder tube	Aluminum alloy	Hard anodised
2	Piston	Aluminum alloy	Chromated
3	Piston rod	Stainless steel	ø12 to ø25
		Carbon steel	ø32 to ø100, Hard chrome plated
4	Collar	Aluminum alloy	ø12 to ø40, Anodised
		Aluminum alloy casted	ø50 to ø100, Chromated, Painted
5	Retaining ring	Carbon tool steel	Phosphate coated
6	Bushing	Bearing alloy	For ø50 or more only
7	Rod end nut	Carbon steel	Nickel plated
8	Bumper A	Urethane	

No.	Description	Material	Note
9	Bumper B	Urethane	
10	Centering location ring	Aluminum alloy	ø20 to ø100, Hard anodised
11	One-touch fitting	—	ø32 to ø63
12	Piston seal	NBR	
13	Rod seal	NBR	
14	Gasket	NBR	

Replacement Parts/Seal Kit (Pneumatic type)

Bore size (mm)	Kit no.	Contents
12	CQ2B12-PS	Kits include items 12, 13, 14 from the table.
16	CQ2B16-PS	
20	CQ2B20-PS	
25	CQ2B25-PS	
32	CQ2B32-PS	
40	CQ2B40-PS	
50	CQ2B50-PS	
63	CQ2B63-PS	
80	CQ2B80-PS	
100	CQ2B100-PS	

Replacement Parts/Seal Kit (Air-hydro type)

Bore size (mm)	Kit no.	Contents
20	CQ2BH20-PS	Kits include items 12, 13, 14 from the table.
25	CQ2BH25-PS	
32	CQ2BH32-PS	
40	CQ2BH40-PS	
50	CQ2BH50-PS	
63	CQ2BH63-PS	
80	CQ2BH80-PS	
100	CQ2BH100-PS	

* Seal kit includes 12, 13, 14. Order the seal kit, based on each bore size.
* Since the seal kit does not include a grease pack, order it separately.
Grease pack part no.: GR-S-010 (10 g)

* Seal kit includes 12, 13, 14. Order the seal kit, based on each bore size.
* Since the seal kit does not include a grease pack, order it separately.
Grease pack part no.: GR-S-010 (10 g)

Standard

Large Bore Size

Long Stroke

Non-rotating Rod

Axial Piping

Anti-lateral Load

With End Lock

Water Resistant

With Auto Switch

Auto Switch

Made to Order

Series CQ2

Clean Series

10 - C□Q2B Bore size - Stroke **D(M)Z**



• Clean series

10	Relief type
11	Vacuum type

• $\phi 12, \phi 16, \phi 20, \phi 25, \phi 32$
 $\phi 40, \phi 50, \phi 63, \phi 80, \phi 100$

Applicable for using inside the clean room graded Class 100 by making an actuator's rod section a double seal construction and discharging by relief port directly to the outside of clean room.

Specifications

Bore size (mm)	12	16	20	25	32	40	50	63	80	100
Action	Double acting, Single rod									
Proof pressure	1.5 MPa									
Maximum operating pressure	1.0 MPa									
Cushion	None ^{Note)}									
Piston speed	30 to 400 mm/s								30 to 300 mm/s	
Mounting	Through-hole									

Note) $\phi 12$ with auto switch: With rubber bumper (Standard)

For details, refer to the separate catalogue (CAT.E02-23), "Pneumatics Equipment for Clean Room."

Construction

10-CQ2 series (Double seal)

A relief port is provided in the area between the double rod seals to discharge the exhaust air outside of the clean room. Thus, the amount of dust generated has been reduced to 1/20 of that of an ordinary cylinder.

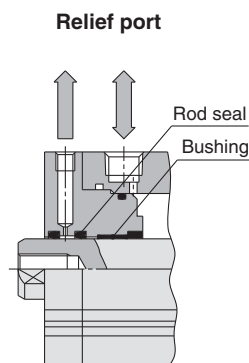

11-CQ2 series (Single seal, Vacuum suction)

Structurally identical to the "10-" series, the outer rod seal has been removed to evacuate through the vacuum port. This draws out any external air from the clearance between the rod and the cover to practically eliminate the generation of external dust. This should be used in an application that requires an even higher level of cleanliness than the 10- series.

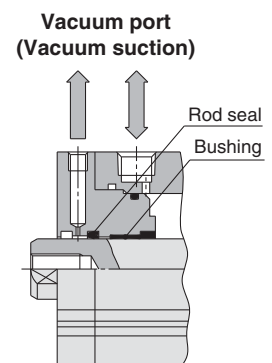

Copper and Fluorine-free Series (For CRT Manufacturing Process)

20 - C□Q2B Bore size - Stroke **D(C)(M)Z**



• Copper and fluorine-free series

• $\phi 12, \phi 16, \phi 20, \phi 25, \phi 32$
 $\phi 40, \phi 50, \phi 63, \phi 80, \phi 100$

For preventing the influence of copper ions or halogen ions during CRT manufacturing processes, copper and fluorine materials are not used in the component parts.

Specifications

Bore size (mm)	12	16	20	25	32	40	50	63	80	100
Action	Double acting, Single rod									
Proof pressure	1.5 MPa									
Maximum operating pressure	1.0 MPa									
Cushion	None/Rubber bumper									
Piston speed	50 to 500 mm/s									
Mounting	Through-hole/Both ends tapped									

Water Resistant

Refer to pages 178 to 190 for details.

CDQ2 **Mounting** **Bore size** **R** - **Stroke** **D** **Option** **Z** - **M9BAL** - **XC6** **Suffix**

- With auto switch (Built-in magnet)
- Water resistant cylinder

R	NBR seals (Nitrile rubber)
V	FKM seals (Fluororubber)
- Water resistant 2-colour indication solid state auto switch
- Made to Order
- Suffix

-	Piston rod/Retaining ring/Rod end nut material: Stainless steel
A	Piston rod/Rod end nut/Cover holding bolt material: Stainless steel

Ideal for use under the atmosphere having coolant for machine tools, etc. Compatible for the environment, where waterdrops are splashed around the food processing machinery and the car washers, etc.



-	Piston rod/Retaining ring/Rod end nut material: Stainless steel
A	Piston rod/Rod end nut/Cover holding bolt material: Stainless steel

Note) -XC6A: ø20 to ø32 only

Specifications

Bore size (mm)	20	25	32	40	50	63	80	100
Action	Double acting, Single rod							
Cushion	None							
Made to Order	Piston rod/Retaining ring/Rod end nut material: Stainless steel (-XC6)							

* The specifications other than above are the same as those of the standard.
Some dimensions may vary from those of the standard. Refer to page 178 for details.

Compact Cylinder with Stable Lubrication Function (Lube-retainer)

CDQ2 **Mounting style** **Bore size** **M** - **Stroke** **D** **Body option** **Z** **Mounting bolt** **Rod end thread** - **Auto switch**

- With auto switch (Built-in magnet)
- With stable lubrication function (Lube-retainer)
- * Available only for with auto switch.

Specifications

Bore size (mm)	32, 40, 50, 63, 80, 100
Action	Double acting, Single rod
Minimum operating pressure	0.1 MPa
Piston speed	50 to 500 mm/s
Cushion	None

* Specifications other than those shown above are the same as the standard model.



Dimensions (Dimensions other than those shown below are the same as the standard model.)

ø32 to ø100

DMZ: Rod end male thread

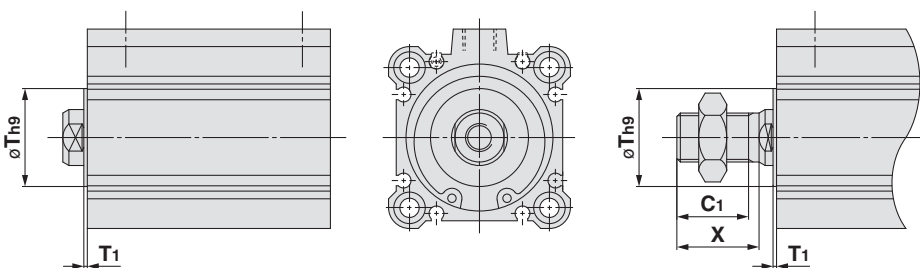

Bore size	T	T ₁	C ₁	X
32	22	1	20.5	23.5
40	28	1	20.5	23.5
50	35	2	24	26.5
63	35	2	24	26.5
80	-	-	32.5	35.5
100	-	-	32.5	35.5

* The mounting dimensions of the mounting bracket are the same as the standard model.

Standard
Large Bore Size
Long Stroke
Non-rotating Rod
Axial Piping
Anti-lateral Load
With End Lock
Water Resistant
With Auto Switch
Auto Switch
Made to Order

Standard: Double Acting, Single Rod Series **CDQ2** With Auto Switch



Refer to the below pages for further information on auto switches.

Auto switch proper mounting position and its mounting height	P.193 to 199
Minimum stroke for auto switch mounting	
Operating range	
Auto switch mounting brackets/Part no.	

Weight

Weight

Bore size (mm)	Cylinder stroke (mm)											
	5	10	15	20	25	30	35	40	45	50	75	100
12	43	49	55	61	67	73	—	—	—	—	—	—
16	64	71	79	87	95	102	—	—	—	—	—	—
20	94	106	118	131	143	155	167	179	191	203	—	—
25	134	149	164	180	195	210	226	241	256	272	—	—
32	182	202	222	241	261	281	300	320	340	359	459	558
40	269	290	312	333	355	376	398	420	441	463	575	687
50	—	455	488	521	554	587	620	653	686	719	891	1062
63	—	627	665	703	741	779	817	855	893	931	1129	1326
80	—	1162	1222	1282	1342	1403	1463	1524	1584	1644	1941	2237
100	—	1966	2047	2127	2208	2288	2368	2449	2529	2610	3018	3426

Additional Weight

Bore size (mm)	12	16	20	25	32	40	50	63	80	100
Both ends tapped	1	1	3	3	6	6	6	19	45	45
Rod end male thread	1.5	3	6	12	26	27	53	53	120	175
male thread Nut	1	2	4	8	17	17	32	32	49	116
With boss on head end	0.7	1.3	2	3	5	7	13	25	45	96
With rubber bumper	0	0	-2	-3	-3	-7	-9	-18	-31	-56
Built-in one-touch fittings	—	—	—	—	12	12	21	21	—	—
Foot (Including mounting bolts)	49	62	147	169	142	154	243	317	683	1052
Compact foot (Including mounting bolts)	32	40	97	116	99	114	117	241	501	770
Rod flange (Including mounting bolts)	54	67	131	153	180	214	373	559	1056	1365
Head flange (Including mounting bolts)	52	63	124	144	165	198	348	534	1017	1309
Double clevis (Including pin, retaining rings, bolts)	29	35	78	114	151	196	393	554	1109	1887

Calculation: (Example) **CDQ2D32-20DCMZ**

- Basic weight: CDQ2B32-20DZ..... 241 g
 - Additional weight: Both ends tapped 6 g
 - Rod end male thread 43 g
 - With rubber bumper -3 g
 - Double clevis 151 g
- 438 g

Add each weight of auto switches when auto switches are mounted.

Construction

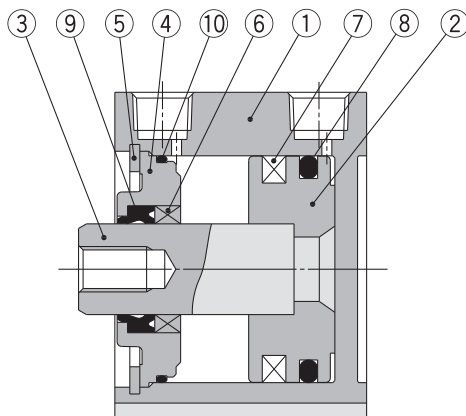

Component Parts

No.	Description	Material	Note
1	Cylinder tube	Aluminum alloy	Hard anodised
2	Piston	Aluminum alloy	Chromated
3	Piston rod	Stainless steel	ø12 to ø25
		Carbon steel	ø32 to ø100, Hard chrome plated
4	Collar	Aluminum alloy	ø12 to ø40, Anodised
		Aluminum alloy casted	ø50 to ø100, Chromated, Painted
5	Retaining ring	Carbon tool steel	Phosphate coated
6	Bushing	Bearing alloy	For ø50 or more only
7	Magnet	—	
8	Piston seal	NBR	
9	Rod seal	NBR	
10	Gasket	NBR	

Replacement Parts/Seal Kit (Pneumatic type)

Bore size (mm)	Kit no.	Contents
12	CQ2B12-PS	Kits include items ⑧, ⑨, ⑩ from the table.
16	CQ2B16-PS	
20	CQ2B20-PS	
25	CQ2B25-PS	
32	CQ2B32-PS	
40	CQ2B40-PS	
50	CQ2B50-PS	
63	CQ2B63-PS	
80	CQ2B80-PS	
100	CQ2B100-PS	

Replacement Parts/Seal Kit (Air-hydro type)

Bore size (mm)	Kit no.	Contents
20	CQ2BH20-PS	Kits include items ⑧, ⑨, ⑩ from the table.
25	CQ2BH25-PS	
32	CQ2BH32-PS	
40	CQ2BH40-PS	
50	CQ2BH50-PS	
63	CQ2BH63-PS	
80	CQ2BH80-PS	
100	CQ2BH100-PS	

- * Seal kit includes ⑧, ⑨, ⑩. Order the seal kit, based on each bore size.
- * Since the seal kit does not include a grease pack, order it separately.

Grease pack part no.: **GR-S-010** (10 g)

- * Seal kit includes ⑧, ⑨, ⑩. Order the seal kit, based on each bore size.
 - * Since the seal kit does not include a grease pack, order it separately.
- Grease pack part no.: **GR-S-010** (10 g)

Mounting Bolt for CDQ2B/With Auto Switch

Mounting method: Mounting bolt for through-hole mounting of the CDQ2B is available as an option. Refer to the following for ordering procedures. Order the actual number of bolts that will be used.

Example) CQ-M3 x 35L 2 pcs.

Material: Chromium molybdenum steel
Surface treatment: Zinc chromated

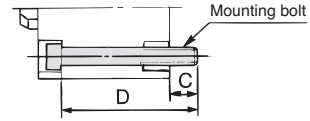

Cylinder model	C	D	Mounting bolt part no.	Cylinder model	C	D	Mounting bolt part no.	Cylinder model	C	D	Mounting bolt part no.
CDQ2B12-5DZ	5.5	35	CQ-M3 x 35L	CDQ2B40-5DZ	7.5	45	CQ-M5 x 45L	CDQ2B80-10DZ	15	65	CQ-M10 x 65L
-10DZ		40	x 40L	-10DZ		50	x 50L	-15DZ		70	x 70L
-15DZ		45	x 45L	-15DZ		55	x 55L	-20DZ		75	x 75L
-20DZ		50	x 50L	-20DZ		60	x 60L	-25DZ		80	x 80L
-25DZ		55	x 55L	-25DZ		65	x 65L	-30DZ		85	x 85L
-30DZ		65	x 60L	-30DZ		70	x 70L	-35DZ		90	x 90L
CDQ2B16-5DZ	8	40	CQ-M3 x 40L	-35DZ		75	x 75L	-40DZ		95	x 95L
-10DZ		45	x 45L	-40DZ		80	x 80L	-45DZ		100	x 100L
-15DZ		50	x 50L	-45DZ		85	x 85L	-50DZ		105	x 105L
-20DZ		55	x 55L	-50DZ		90	x 90L	-55DZ-XB10		110	x 110L
-25DZ		60	x 60L	-55DZ-XB10	95	x 95L	-60DZ-XB10	115	x 115L		
-30DZ		65	x 65L	-60DZ-XB10	100	x 100L	-65DZ-XB10	120	x 120L		
CDQ2B20-5DZ	10.5	40	CQ-M5 x 40L	-65DZ-XB10	105	x 105L	-70DZ-XB10	125	x 125L		
-10DZ		45	x 45L	-70DZ-XB10	110	x 110L	-75DZ	130	x 130L		
-15DZ		50	x 50L	-75DZ	115	x 115L	-80DZ-XB10	135	x 135L		
-20DZ		55	x 55L	-80DZ-XB10	120	x 120L	-85DZ-XB10	140	x 140L		
-25DZ		60	x 60L	-85DZ-XB10	125	x 125L	-90DZ-XB10	145	x 145L		
-30DZ		65	x 65L	-90DZ-XB10	130	x 130L	-95DZ-XB10	150	x 150L		
-35DZ		70	x 70L	-95DZ-XB10	135	x 135L	-100DZ	155	x 155L		
-40DZ		75	x 75L	-100DZ	140	x 140L	CDQ2B100-10DZ	75	CQ-M10 x 75L		
-45DZ	80	x 80L	CDQ2B50-10DZ	55	CQ-M6 x 55L	-15DZ	80	x 80L			
-50DZ	85	x 85L	-15DZ	60	x 60L	-20DZ	85	x 85L			
CDQ2B25-5DZ	9.5	40	CQ-M5 x 40L	-20DZ	65	x 65L	-25DZ	90	x 90L		
-10DZ		45	x 45L	-25DZ	70	x 70L	-30DZ	95	x 95L		
-15DZ		50	x 50L	-30DZ	75	x 75L	-35DZ	100	x 100L		
-20DZ		55	x 55L	-35DZ	80	x 80L	-40DZ	105	x 105L		
-25DZ		60	x 60L	-40DZ	85	x 85L	-45DZ	110	x 110L		
-30DZ		65	x 65L	-45DZ	90	x 90L	-50DZ	115	x 115L		
-35DZ		70	x 70L	-50DZ	95	x 95L	-55DZ-XB10	120	x 120L		
-40DZ		75	x 75L	-55DZ-XB10	100	x 100L	-60DZ-XB10	125	x 125L		
-45DZ	80	x 80L	-60DZ-XB10	105	x 105L	-65DZ-XB10	130	x 130L			
-50DZ	85	x 85L	-65DZ-XB10	110	x 110L	-70DZ-XB10	135	x 135L			
CDQ2B32-5DZ	9	40	CQ-M5 x 40L	-70DZ-XB10	115	x 115L	-75DZ	140	x 140L		
-10DZ		45	x 45L	-75DZ	120	x 120L	-80DZ-XB10	145	x 145L		
-15DZ		50	x 50L	-80DZ-XB10	125	x 125L	-85DZ-XB10	150	x 150L		
-20DZ		55	x 55L	-85DZ-XB10	130	x 130L	-90DZ-XB10	155	x 155L		
-25DZ		60	x 60L	-90DZ-XB10	135	x 135L	-95DZ-XB10	160	x 160L		
-30DZ		65	x 65L	-95DZ-XB10	140	x 140L	-100DZ	165	x 165L		
-35DZ		70	x 70L	-100DZ	145	x 145L					
-40DZ		75	x 75L	CDQ2B63-10DZ	60	CQ-M8 x 60L					
-45DZ		80	x 80L	-15DZ	65	x 65L					
-50DZ		85	x 85L	-20DZ	70	x 70L					
-55DZ-XB10		90	x 90L	-25DZ	75	x 75L					
-60DZ-XB10		95	x 95L	-30DZ	80	x 80L					
-65DZ-XB10		100	x 100L	-35DZ	85	x 85L					
-70DZ-XB10		105	x 105L	-40DZ	90	x 90L					
-75DZ	110	x 110L	-45DZ	95	x 95L						
-80DZ-XB10	115	x 115L	-50DZ	100	x 100L						
-85DZ-XB10	120	x 120L	-55DZ-XB10	105	x 105L						
-90DZ-XB10	125	x 125L	-60DZ-XB10	110	x 110L						
-95DZ-XB10	130	x 130L	-65DZ-XB10	115	x 115L						
-100DZ	135	x 135L	-70DZ-XB10	120	x 120L						
			-75DZ	125	x 125L						
			-80DZ-XB10	130	x 130L						
			-85DZ-XB10	135	x 135L						
			-90DZ-XB10	140	x 140L						
			-95DZ-XB10	145	x 145L						
			-100DZ	150	x 150L						

- Standard
- Large Bore Size
- Long Stroke
- Non-rotating Rod
- Axial Piping
- Anti-lateral Load
- With End Lock
- Water Resistant
- With Auto Switch
- Auto Switch
- Made to Order

Series CQ2

Dimensions

Ø12 to Ø25/Without Auto Switch

Both ends tapped: CQ2A

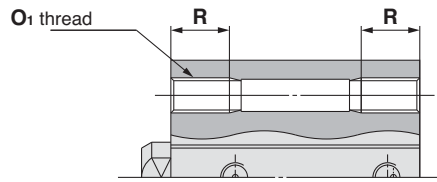

Both Ends Tapped (mm)

Bore size (mm)	O ₁	R
12	M4 x 0.7	7
16	M4 x 0.7	7
20	M6 x 1.0	10
25	M6 x 1.0	10

Standard (Through-hole): CQ2B

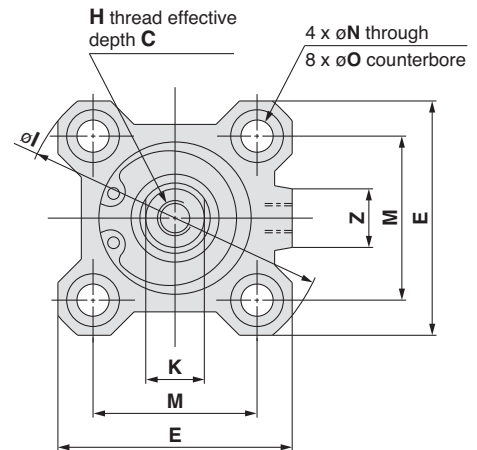
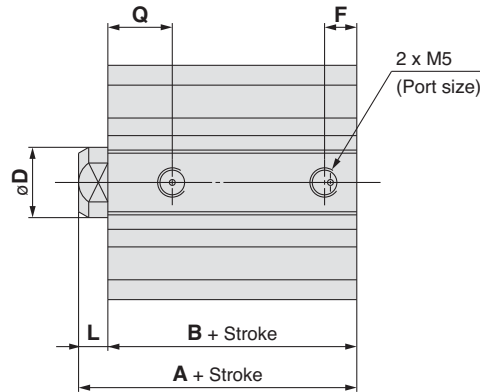

With boss on head side

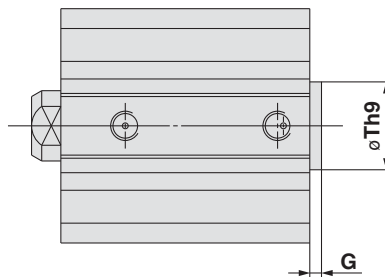

With Boss on Head side (mm)

Bore size (mm)	G	Th9
12	1.5	15 ⁰ _{-0.043}
16	1.5	20 ⁰ _{-0.052}
20	2	13 ⁰ _{-0.043}
25	2	15 ⁰ _{-0.043}

Note 1) With boss on rod end: Option (Suffix "-XC36" to the end of model number.)

Rod end male thread

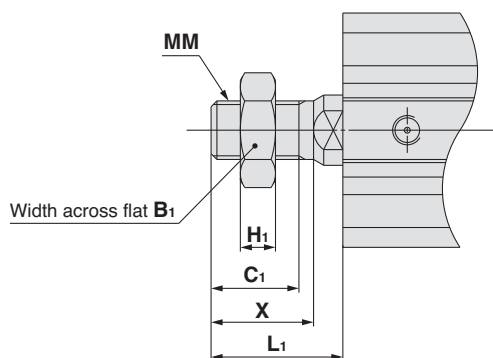

Rod End Male Thread (mm)

Bore size (mm)	B ₁	C ₁	H ₁	L ₁	MM	X
12	8	9	4	14	M5 x 0.8	10.5
16	10	10	5	15.5	M6 x 1.0	12
20	13	12	5	18.5	M8 x 1.25	14
25	17	15	6	22.5	M10 x 1.25	17.5

Standard

Bore size (mm)	Stroke range (mm)	A	B	C	D	E	F	H	I	K	L	M	N	O	Q	Z
12	5 to 30	20.5	17	6	6	25	5	M3 x 0.5	32	5	3.5	15.5	3.5	6.5 depth 3.5	7.5	-
16	5 to 30	22	18.5	8	8	29	5.5	M4 x 0.7	38	6	3.5	20	3.5	6.5 depth 3.5	8	10
20	5 to 50	24	19.5	7	10	36	5.5	M5 x 0.8	47	8	4.5	25.5	5.5	9 depth 7	8	10
25	5 to 50	27.5	22.5	12	12	40	5.5	M6 x 1.0	52	10	5	28	5.5	9 depth 7	9	10

Note 2) The external dimensions with rubber bumper are same as those of the standard, as shown above.

* For details about the rod end nut and accessory brackets, refer to page 23.

Note 3) For calculation on the longitudinal dimension of intermediate strokes, refer to page 3.

Foot: CQ2L

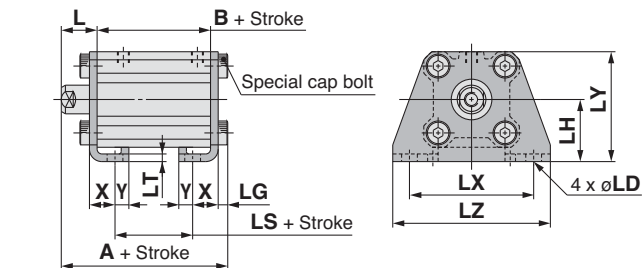

Foot

Bore size (mm)	Stroke range (mm)	A	B	L	L ₁	LD	LG	LH	LS	LT	LX	LY	LZ	X	Y
12	5 to 30	35.3	17	13.5	24	4.5	2.8	17	5	2	34	29.5	44	8	4.5
16	5 to 30	36.8	18.5	13.5	25.5	4.5	2.8	19	6.5	2	38	33.5	48	8	5
20	5 to 50	41.2	19.5	14.5	28.5	6.6	4	24	7.5	3.2	48	42	62	9.2	5.8
25	5 to 50	44.7	22.5	15	32.5	6.6	4	26	7.5	3.2	52	46	66	10.7	5.8

Foot bracket material: Carbon steel
Surface treatment: Nickel plated

Rod end male thread

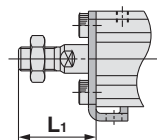

Compact foot: CQ2LC

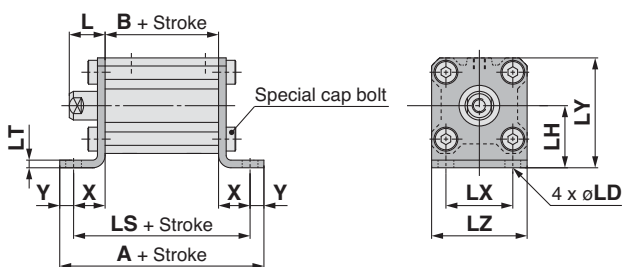

Compact Foot

Bore size (mm)	Stroke range (mm)	A	B	L	L ₁	LD	LH	LS	LT	LX	LY	LZ	X	Y
12	5 to 30	44.6	17	13.5	24	4.5	17	35.6	2	15.5	29.5	25	9.3	4.5
16	5 to 30	47.1	18.5	13.5	25.5	4.5	19	37.1	2	20	33.5	29	9.3	5
20	5 to 50	57.5	19.5	14.5	28.5	6.6	24	45.9	3.2	25.5	42	36	13.2	5.8
25	5 to 50	60.5	22.5	15	32.5	6.6	26	48.9	3.2	28	46	40	13.2	5.8

Compact foot bracket material: Carbon steel
Surface treatment: Zinc chromated

Rod end male thread

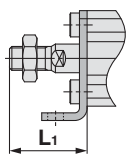

Rod flange: CQ2F

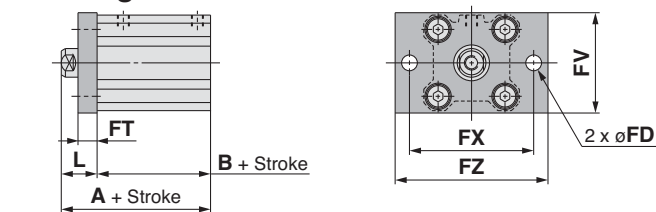

Rod Flange

Bore size (mm)	Stroke range (mm)	A	B	FD	FT	FV	FX	FZ	L	L ₁
12	5 to 30	30.5	17	4.5	5.5	25	45	55	13.5	24
16	5 to 30	32	18.5	4.5	5.5	30	45	55	13.5	25.5
20	5 to 50	34	19.5	6.6	8	39	48	60	14.5	28.5
25	5 to 50	37.5	22.5	6.6	8	42	52	64	15	32.5

Flange bracket material: Carbon steel
Surface treatment: Nickel plated

Rod end male thread

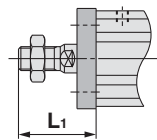

Head flange: CQ2G

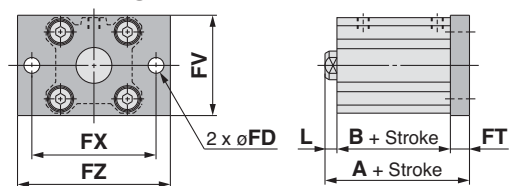

Head Flange

Bore size (mm)	Stroke range (mm)	A	L	L ₁
12	5 to 30	26	3.5	14
16	5 to 30	27.5	3.5	15.5
20	5 to 50	32	4.5	18.5
25	5 to 50	35.5	5	22.5

(* The dimensions except A, L and L₁ are the same as those of the rod flange.)

Flange bracket material: Carbon steel
Surface treatment: Nickel plated

Rod end male thread

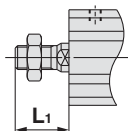

Standard

Large Bore Size

Long Stroke

Non-rotating Rod

Axial Piping

Anti-lateral Load

With End Lock

Water Resistant

With Auto Switch

Auto Switch

Made to Order

Compact Cylinder: Standard
Double Acting, Single Rod **Series CQ2**

Double clevis: CQ2D

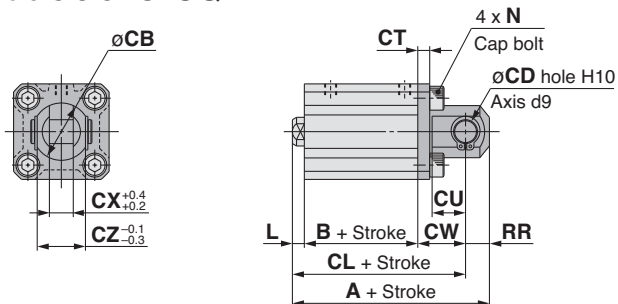

Rod end male thread

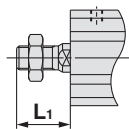

Double Clevis

(mm)

Bore size (mm)	Stroke range (mm)	A	B	CB	CD	CL	CT	CU	CW	CX	CZ	L	L ₁	N	RR
12	5 to 30	40.5	17	12	5	34.5	4	7	14	5	10	3.5	14	M4 x 0.7	6
16	5 to 30	43	18.5	14	5	37	4	10	15	6.5	12	3.5	15.5	M4 x 0.7	6
20	5 to 50	51	19.5	20	8	42	5	12	18	8	16	4.5	18.5	M6 x 1.0	9
25	5 to 50	57.5	22.5	24	10	47.5	5	14	20	10	20	5	22.5	M6 x 1.0	10

Double clevis bracket material: Carbon steel
Surface treatment: Nickel plated

- * For details about the rod end nut and accessory brackets, refer to page 23.
- * Double clevis pin and retaining rings are included.

Series CQ2

Foot: CDQ2L

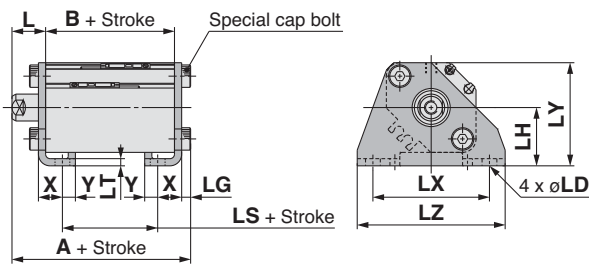

Rod end male thread

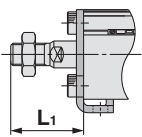

Compact foot: CDQ2LC

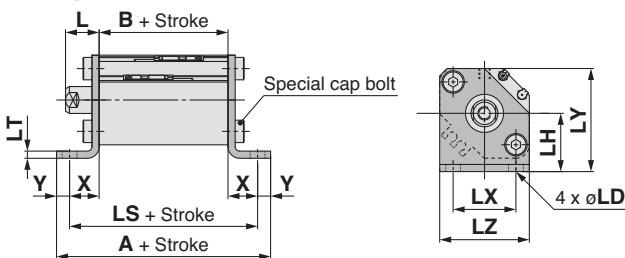

Rod end male thread

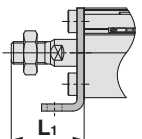

Rod flange: CDQ2F

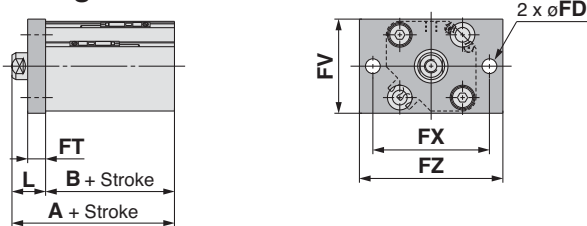

Rod end male thread

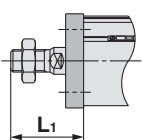

Head flange: CDQ2G

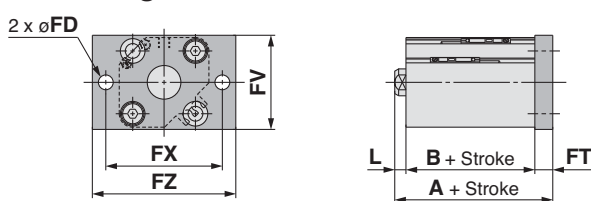

Rod end male thread

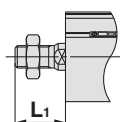

Foot

		(mm)													
Bore size (mm)	Stroke range (mm)	A	B	L	L ₁	LD	LG	LH	LS	LT	LX	LY	LZ	X	Y
12	5 to 30	46.3	28	13.5	24	4.5	2.8	17	16	2	34	29.5	44	8	4.5
16	5 to 30	48.8	30.5	13.5	25.5	4.5	2.8	19	18.5	2	38	33.5	48	8	5
20	5 to 50	53.2	31.5	14.5	28.5	6.6	4	24	19.5	3.2	48	42	62	9.2	5.8
25	5 to 50	54.7	32.5	15	32.5	6.6	4	26	17.5	3.2	52	46	66	10.7	5.8

Foot bracket material: Carbon steel
Surface treatment: Nickel plated

Compact Foot

		(mm)													
Bore size (mm)	Stroke range (mm)	A	B	L	L ₁	LD	LH	LS	LT	LX	LY	LZ	X	Y	
12	5 to 30	55.6	28	13.5	24	4.5	17	46.6	2	15.5	29.5	25	9.3	4.5	
16	5 to 30	59.1	30.5	13.5	25.5	4.5	19	49.1	2	20	33.5	29	9.3	5	
20	5 to 50	69.5	31.5	14.5	28.5	6.6	24	57.9	3.2	25.5	42	36	13.2	5.8	
25	5 to 50	70.5	32.5	15	32.5	6.6	26	58.9	3.2	28	46	40	13.2	5.8	

Compact foot bracket material: Carbon steel
Surface treatment: Zinc chromated

Rod Flange

		(mm)									
Bore size (mm)	Stroke range (mm)	A	B	FD	FT	FV	FX	FZ	L	L ₁	
12	5 to 30	41.5	28	4.5	5.5	25	45	55	13.5	24	
16	5 to 30	44	30.5	4.5	5.5	30	45	55	13.5	25.5	
20	5 to 50	46	31.5	6.6	8	39	48	60	14.5	28.5	
25	5 to 50	47.5	32.5	6.6	8	42	52	64	15	32.5	

Flange bracket material: Carbon steel
Surface treatment: Nickel plated

Head Flange

		(mm)		
Bore size (mm)	Stroke range (mm)	A	L	L ₁
12	5 to 30	37	3.5	14
16	5 to 30	39.5	3.5	15.5
20	5 to 50	44	4.5	18.5
25	5 to 50	45.5	5	22.5

(* The dimensions except A, L and L₁ are the same as those of the rod flange.)

Head flange bracket material: Carbon steel
Surface treatment: Nickel plated

Double clevis: CDQ2D

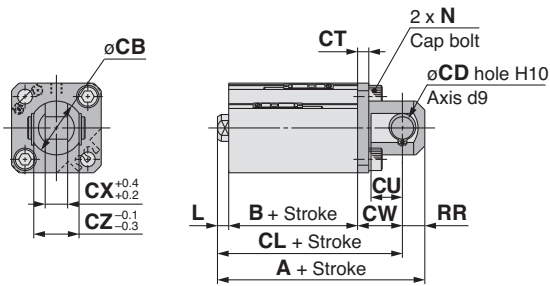

Rod end male thread

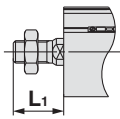

Double Clevis

Bore size (mm)	Stroke range (mm)	A	B	CB	CD	CL	CT	CU	CW	CX	CZ	L	L ₁	N	RR
12	5 to 30	51.5	28	12	5	45.5	4	7	14	5	10	3.5	14	M4 x 0.7	6
16	5 to 30	55	30.5	14	5	49	4	10	15	6.5	12	3.5	15.5	M4 x 0.7	6
20	5 to 50	63	31.5	20	8	54	5	12	18	8	16	4.5	18.5	M6 x 1.0	9
25	5 to 50	67.5	32.5	24	10	57.5	5	14	20	10	20	5	22.5	M6 x 1.0	10

Double clevis bracket material: Carbon steel
Surface treatment: Nickel plated

- * For details about the rod end nut and accessory brackets, refer to page 23.
- * Double clevis pin and retaining rings are included.

Standard

Large Bore Size

Long Stroke

Non-rotating Rod

Axial Piping

Anti-lateral Load

With End Lock

Water Resistant

With Auto Switch

Auto Switch

Made to Order

Series CQ2

Dimensions

Ø32 to Ø50/With Auto Switch

(In the case of without auto switches, the A, B, F, P and Q dimensions will be only changed. Refer to the dimension table.)

Both ends tapped: CQ2A/CDQ2A

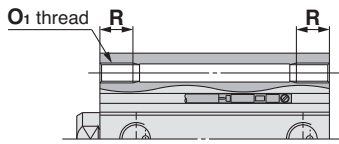

Standard (Through-hole): CQ2B/CDQ2B

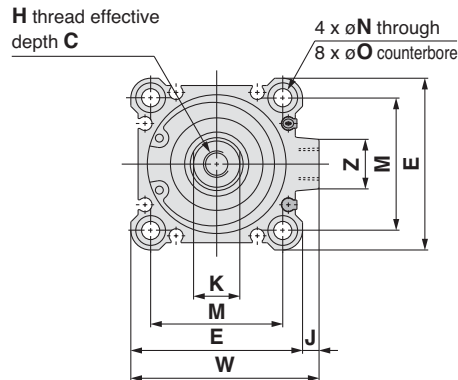
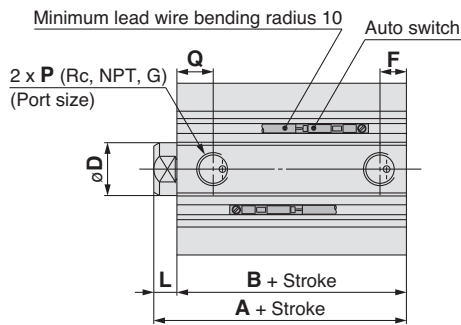

Both Ends Tapped (mm)

Bore size (mm)	O ₁	R
32	M6 x 1.0	10
40	M6 x 1.0	10
50	M8 x 1.25	14

With boss on head side

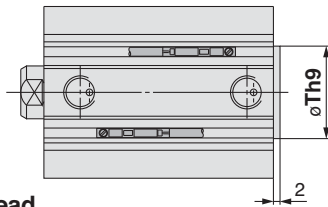

With Boss on Head Side (mm)

Bore size (mm)	Th9
32	21 ⁰ _{-0.052}
40	28 ⁰ _{-0.052}
50	35 ⁰ _{-0.062}

Rod end male thread

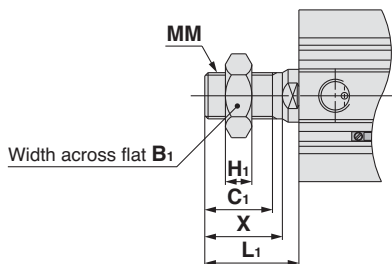

Note 1) With boss on rod end: Option (Suffix "-XC36" to the end of model number.)

Rod End Male Thread (mm)

Bore size (mm)	B ₁	C ₁	H ₁	L ₁	MM	X
32	22	20.5	8	28.5	M14 x 1.5	23.5
40	22	20.5	8	28.5	M14 x 1.5	23.5
50	27	26	11	33.5	M18 x 1.5	28.5

Built-in one-touch fittings: Ø32 to Ø50

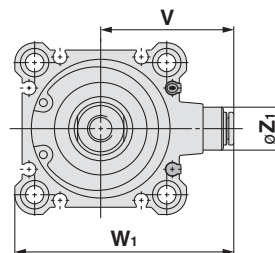
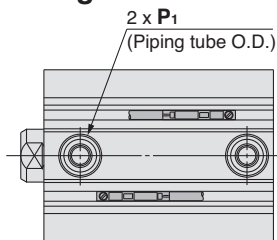

Built-in One-touch Fittings (mm)

Bore size (mm)	Z ₁	P ₁	V	W ₁
32	13	6	36.5	59
40	13	6	40.5	66
50	16	8	50	82

Standard For auto switch proper mounting position and its mounting height, refer to pages 193 to 199.

Bore size (mm)	Stroke range (mm)	Without auto switch					With auto switch					C	D	E	H	J	K	L	M	N
		A	B	F	P	Q	A	B	F	P	Q									
32	5	30	23	5.5	M5 x 0.8	10	40	33	7.5	1/8	10	13	16	45	M8 x 1.25	4.5	14	7	34	5.5
	10 to 50	40	33	7.5	1/8	10	40	33	7.5	1/8	10	13	16	45	M8 x 1.25	4.5	14	7	34	5.5
	75, 100	40	33	7.5	1/8	10	40	33	7.5	1/8	10	13	16	45	M8 x 1.25	4.5	14	7	34	5.5
40	5 to 50	36.5	29.5	7.5	1/8	12.5	46.5	39.5	7.5	1/8	12.5	13	16	52	M8 x 1.25	5	14	7	40	5.5
	75, 100	46.5	39.5	7.5	1/8	12.5	46.5	39.5	7.5	1/8	12.5	13	16	52	M8 x 1.25	5	14	7	40	5.5
	10 to 50	38.5	30.5	10.5	1/4	10.5	48.5	40.5	10.5	1/4	10.5	15	20	64	M10 x 1.5	7	17	8	50	6.6
50	75, 100	48.5	40.5	10.5	1/4	10.5	48.5	40.5	10.5	1/4	10.5	15	20	64	M10 x 1.5	7	17	8	50	6.6

Bore size (mm)	O	W	Z
32	9 depth 7	49.5	14
40	9 depth 7	57	15
50	11 depth 8	71	19

Note 2) The external dimensions with rubber bumper are same as those of the standard, as shown above.

* For details about the rod end nut and accessory brackets, refer to page 23.

Note 3) For calculation on the longitudinal dimension of intermediate strokes, refer to page 3. The spacer-installed type (Standard, -XB10A) and the exclusive body type (-XB10) are available.

Foot: CQ2L/CDQ2L

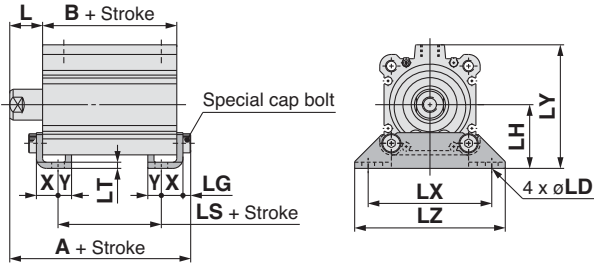

Rod end male thread

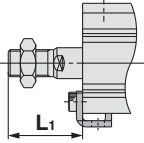

Compact foot: CQ2LC/CDQ2LC

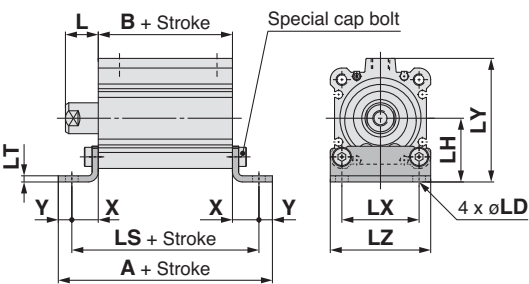

Rod end male thread

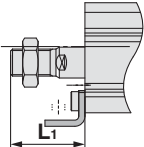

Rod flange: CQ2F/CDQ2F

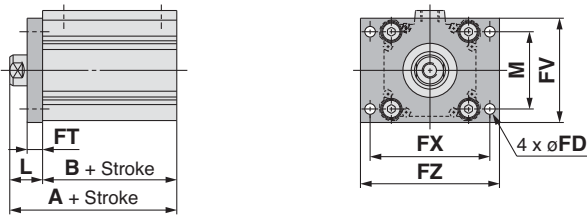

Rod end male thread

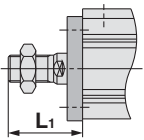

Head flange: CQ2G/CDQ2G

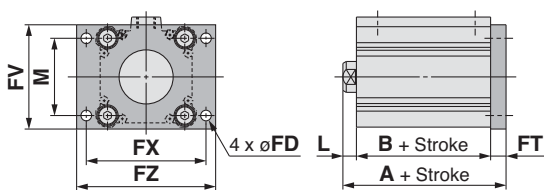

Rod end male thread

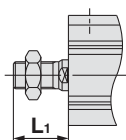

Foot

Bore size (mm)	Stroke range (mm)	Without auto switch			With auto switch			(mm)							
		A	B	LS	A	B	LS	L	L ₁	LD	LG	LH	LT	LX	LY
		32	5 to 50 75, 100	47.2 57.2	23 33	7 17	57.2	33	17	17	38.5	6.6	4	30	3.2
40	5 to 50 75, 100	53.7 63.7	29.5 39.5	13.5 23.5	63.7	39.5	23.5	17	38.5	6.6	4	33	3.2	64	64
50	10 to 50 75, 100	56.7 66.7	30.5 40.5	7.5 17.5	66.7	40.5	17.5	18	43.5	9	5	39	3.2	79	78

Foot bracket material: Carbon steel
Surface treatment: Nickel plated

Bore size (mm)	LZ	X	Y
32	71	11.2	5.8
40	78	11.2	7
50	95	14.7	8

Compact Foot

Bore size (mm)	Stroke range (mm)	Without auto switch			With auto switch			(mm)							
		A	B	LS	A	B	LS	L	L ₁	LD	LH	LT	LX	LY	LZ
		32	5 to 50 75, 100	62 72	23 33	50.4 60.4	72	33	60.4	17	38.5	6.6	30	3.2	34
40	5 to 50 75, 100	70.9 80.9	29.5 39.5	56.9 66.9	80.9	39.5	66.9	17	38.5	6.6	33	3.2	40	64	52
50	10 to 50 75, 100	79.9 89.9	30.5 40.5	63.9 73.9	89.9	40.5	73.9	18	43.5	9	39	3.2	50	78	64

Compact foot bracket material: Carbon steel
Surface treatment: Zinc chromated

Bore size (mm)	X	Y
32	13.7	5.8
40	13.7	7
50	16.7	8

Rod Flange

Bore size (mm)	Stroke range (mm)	Without auto switch		With auto switch		(mm)							
		A	B	A	B	FD	FT	FV	FX	FZ	L	L ₁	M
		32	5 to 50 75, 100	40 50	23 33	50	33	5.5	8	48	56	65	17
40	5 to 50 75, 100	46.5 56.5	29.5 39.5	56.5	39.5	5.5	8	54	62	72	17	38.5	40
50	10 to 50 75, 100	48.5 58.5	30.5 40.5	58.5	40.5	6.6	9	67	76	89	18	43.5	50

Flange bracket material: Carbon steel
Surface treatment: Nickel plated

Head Flange

Bore size (mm)	Stroke range (mm)	Without auto switch		With auto switch		(mm)	
		A		A		L	L ₁
		32	5 to 50 75, 100	38 48		48	
40	5 to 50 75, 100	44.5 54.5		54.5		7	28.5
50	10 to 50 75, 100	47.5 57.5		57.5		8	33.5

(* The dimensions except A, L and L₁ are the same as those of the rod flange.)

Flange bracket material: Carbon steel
Surface treatment: Nickel plated

Standard

Large Bore Size

Long Stroke

Non-rotating Rod

Axial Piping

Anti-lateral Load

With End Lock

Water Resistant

With Auto Switch

Auto Switch

Made to Order

Compact Cylinder: Standard Double Acting, Single Rod **Series CQ2**

Double clevis: CQ2D/CDQ2D

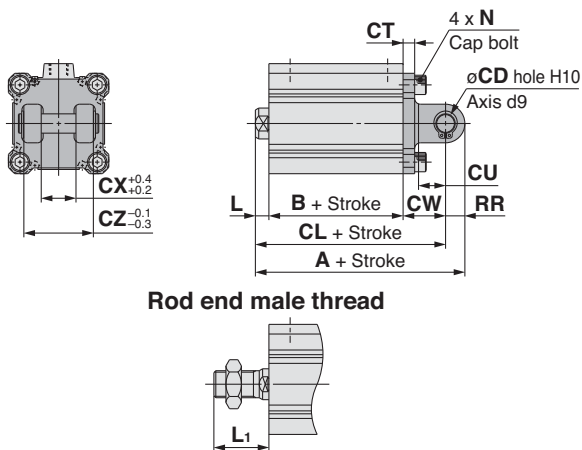

Double Clevis

(mm)

Bore size (mm)	Stroke range (mm)	Without auto switch			With auto switch			CD	CT	CU	CW	CX	CZ	L	L ₁
		A	B	CL	A	B	CL								
32	5 to 50	60	23	50	70	33	60	10	5	14	20	18	36	7	28.5
	75, 100	70	33	60	78.5	39.5	68.5	10	6	14	22	18	36	7	28.5
40	5 to 50	68.5	29.5	58.5	78.5	39.5	68.5	10	6	14	22	18	36	7	28.5
	75, 100	78.5	39.5	68.5	90.5	40.5	76.5	14	7	20	28	22	44	8	33.5
50	10 to 50	80.5	30.5	66.5	90.5	40.5	76.5	14	7	20	28	22	44	8	33.5
	75, 100	90.5	40.5	76.5											

Double clevis bracket material: Cast iron
Surface treatment: Painted

Bore size (mm)	N	RR
32	M6 x 1.0	10
40	M6 x 1.0	10
50	M8 x 1.25	14

- * For details about the rod end nut and accessory brackets, refer to page 23.
- * Double clevis pin and retaining rings are included.

Series CQ2

Dimensions

Ø63 to Ø100/With Auto Switch

(In the case of without auto switches, the A, B dimensions will be only changed. Refer to the dimension table.)

Both ends tapped: CQ2A/CDQ2A

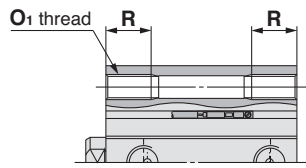

Both Ends Tapped (mm)

Bore size (mm)	O ₁	R
63	M10 x 1.5	18
80	M12 x 1.75	22
100	M12 x 1.75	22

Standard (Through-hole): CQ2B/CDQ2B

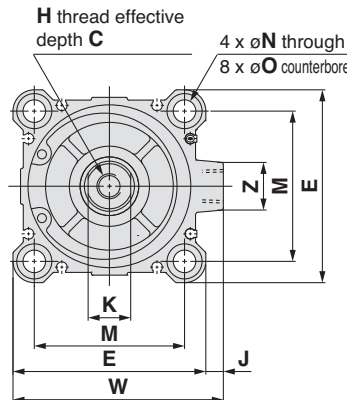
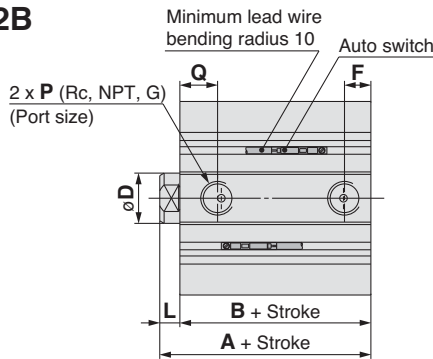

With Boss on Head Side (mm)

Bore size (mm)	Th9
63	35 ⁰ _{-0.062}
80	43 ⁰ _{-0.062}
100	59 ⁰ _{-0.074}

Note 1) With boss on rod end:
Option (Suffix "-XC36" to the end of model number.)

With boss on head end

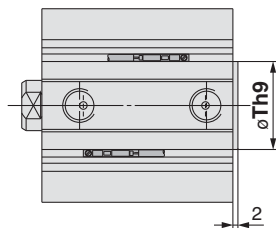

Rod end male thread

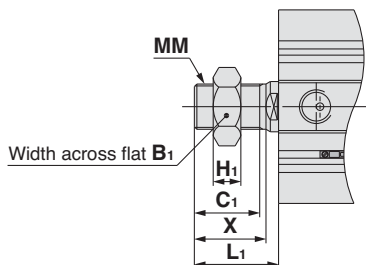

Rod End Male Thread (mm)

Bore size (mm)	B ₁	C ₁	H ₁	L ₁	MM	X
63	27	26	11	33.5	M18 x 1.5	28.5
80	32	32.5	13	43.5	M22 x 1.5	35.5
100	41	32.5	16	43.5	M26 x 1.5	35.5

Built-in one-touch fittings: Ø63

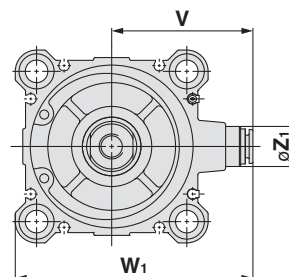
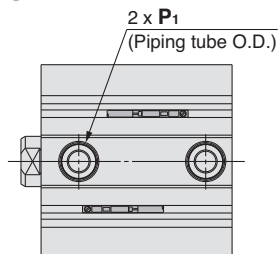

Built-in One-touch Fittings (mm)

Bore size (mm)	Z ₁	P ₁	V	W ₁
63	16	8	56.5	95

Standard For auto switch proper mounting position and its mounting height, refer to pages 193 to 199.

Bore size (mm)	Stroke range (mm)	Without auto switch		With auto switch		C	D	E	F	H	J	K	L	M	N	O	P	Q	W	Z
		A	B	A	B															
63	10 to 50	44	36	54	46	15	20	77	10.5	M10 x 1.5	7	17	8	60	9	14 depth 10.5	1/4	15	84	19
	75, 100	54	46																	
80	10 to 50	53.5	43.5	63.5	53.5	21	25	98	12.5	M16 x 2.0	6	22	10	77	11	17.5 depth 13.5	3/8	16	104	25
	75, 100	63.5	53.5																	
100	10 to 50	65	53	75	63	27	30	117	13	M20 x 2.5	6.5	27	12	94	11	17.5 depth 13.5	3/8	23	123.5	25
	75, 100	75	63																	

Note 2) The external dimensions with rubber bumper are same as those of the standard, as shown above.

* For details about the rod end nut and accessory brackets, refer to page 23.

Note 3) For calculation on the longitudinal dimension of intermediate strokes, refer to page 3.

Compact Cylinder: Standard Double Acting, Single Rod *Series CQ2*

Foot: CQ2L/CDQ2L

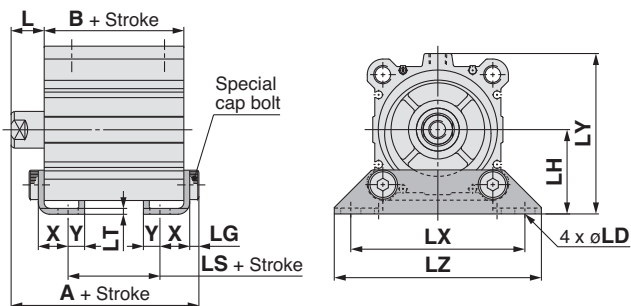

Rod end male thread

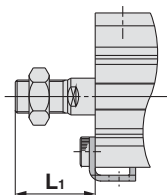

Foot

Bore size (mm)	Stroke range (mm)	Without auto switch			With auto switch			L	L ₁	LD	LG	LH	LT
		A	B	LS	A	B	LS						
63	10 to 50	62.2	36	10	72.2	46	20	18	43.5	11	5	46	3.2
	75, 100	72.2	46	20									
80	10 to 50	75	43.5	13.5	85	53.5	23.5	20	53.5	13	7	59	4.5
	75, 100	85	53.5	23.5									
100	10 to 50	88	53	19	98	63	29	22	53.5	13	7	71	6
	75, 100	98	63	29									

Foot bracket material: Carbon steel
Surface treatment: Nickel plated

Bore size (mm)	Stroke range (mm)	LX	LY	LZ	X	Y
63	10 to 50	95	91.5	113	16.2	9
	75, 100	118	114	140	19.5	11
80	10 to 50	118	114	140	19.5	11
	75, 100	137	136	162	23	12.5
100	10 to 50	137	136	162	23	12.5
	75, 100	137	136	162	23	12.5

Compact foot: CQ2LC/CDQ2LC

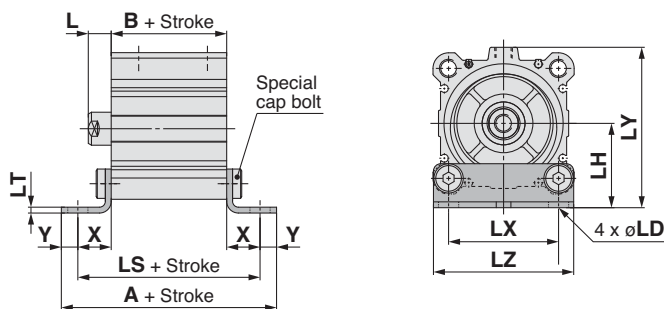

Rod end male thread

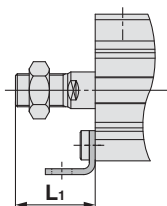

Compact Foot

Bore size (mm)	Stroke range (mm)	Without auto switch			With auto switch			L	L ₁	LD	LH	LT	LX
		A	B	LS	A	B	LS						
63	10 to 50	90.4	36	72.4	100.4	46	82.4	18	43.5	11	46	3.2	60
	75, 100	100.4	46	82.4									
80	10 to 50	110.5	43.5	88.5	120.5	53.5	98.5	20	53.5	13	59	4.5	77
	75, 100	120.5	53.5	98.5									
100	10 to 50	126	53	101	136	63	111	22	53.5	13	71	6	94
	75, 100	136	63	111									

Compact foot bracket material: Carbon steel
Surface treatment: Zinc chromated

Bore size (mm)	Stroke range (mm)	LY	LZ	X	Y
63	10 to 50	91.5	77	18.2	9
	75, 100	114	98	22.5	11
80	10 to 50	114	98	22.5	11
	75, 100	136	117	24	12.5
100	10 to 50	136	117	24	12.5
	75, 100	136	117	24	12.5

* For details about the rod end nut and accessory brackets, refer to page 23.

Rod flange: CQ2F/CDQ2F

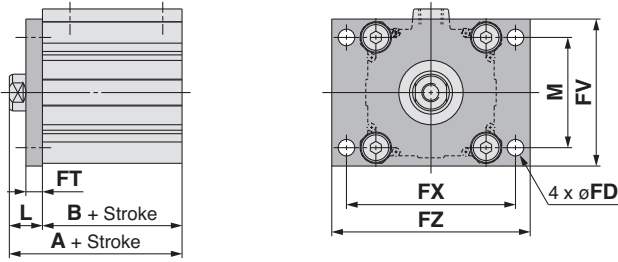

Rod end male thread

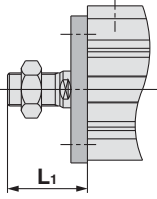

Foot (mm)

Bore size (mm)	Stroke range (mm)	Without auto switch			With auto switch			L	L ₁	LD	LG	LH	LT
		A	B	LS	A	B	LS						
63	10 to 50	62.2	36	10	72.2	46	20	18	43.5	11	5	46	3.2
	75, 100	72.2	46	20	72.2	46	20	18	43.5	11	5	46	3.2
80	10 to 50	75	43.5	13.5	85	53.5	23.5	20	53.5	13	7	59	4.5
	75, 100	85	53.5	23.5	85	53.5	23.5	20	53.5	13	7	59	4.5
100	10 to 50	88	53	19	98	63	29	22	53.5	13	7	71	6
	75, 100	98	63	29	98	63	29	22	53.5	13	7	71	6

Foot bracket material: Carbon steel
Surface treatment: Nickel plated

Bore size (mm)	Stroke range (mm)	LX	LY	LZ	X	Y
63	10 to 50	95	91.5	113	16.2	9
	75, 100	95	91.5	113	16.2	9
80	10 to 50	118	114	140	19.5	11
	75, 100	118	114	140	19.5	11
100	10 to 50	137	136	162	23	12.5
	75, 100	137	136	162	23	12.5

Rod Flange (mm)

Bore size (mm)	Stroke range (mm)	Without auto switch		With auto switch		FD	FT	FV	FX	FZ	L	L ₁	M
		A	B	A	B								
63	10 to 50	54	36	64	46	9	9	80	92	108	18	43.5	60
	75, 100	64	46	64	46	9	9	80	92	108	18	43.5	60
80	10 to 50	63.5	43.5	73.5	53.5	11	11	99	116	134	20	53.5	77
	75, 100	73.5	53.5	73.5	53.5	11	11	99	116	134	20	53.5	77
100	10 to 50	75	53	85	63	11	11	117	136	154	22	53.5	94
	75, 100	85	63	85	63	11	11	117	136	154	22	53.5	94

Flange bracket material: Carbon steel
Surface treatment: Nickel plated

Double clevis: CQ2D/CDQ2D

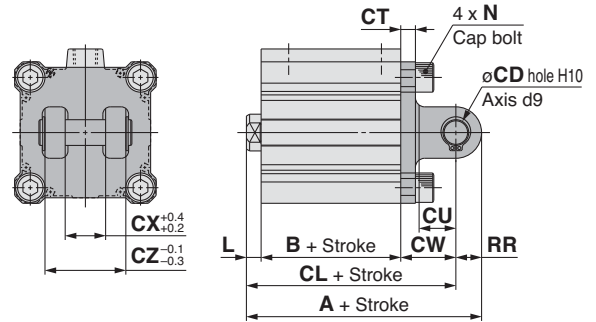

Rod end male thread

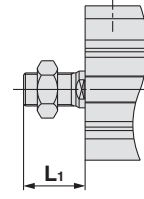

Head Flange (mm)

Bore size (mm)	Stroke range (mm)	Without auto switch		With auto switch		L	L ₁
		A	A	A	A		
63	10 to 50	53	53	63	63	8	33.5
	75, 100	63	63	63	63	8	33.5
80	10 to 50	64.5	64.5	74.5	74.5	10	43.5
	75, 100	74.5	74.5	74.5	74.5	10	43.5
100	10 to 50	76	76	86	86	12	43.5
	75, 100	86	86	86	86	12	43.5

(* The dimensions except A, L and L₁ are the same as those of the rod flange.)

Flange bracket material: Carbon steel Surface treatment: Nickel plated

Double Clevis (mm)

Bore size (mm)	Stroke range (mm)	Without auto switch			With auto switch			CD	CT	CU	CW	CX
		A	B	CL	A	B	CL					
63	10 to 50	88	36	74	98	46	84	14	8	20	30	22
	75, 100	98	46	84	98	46	84	14	8	20	30	22
80	10 to 50	109.5	43.5	91.5	119.5	53.5	101.5	18	10	27	38	28
	75, 100	119.5	53.5	101.5	119.5	53.5	101.5	18	10	27	38	28
100	10 to 50	132	53	110	142	63	120	22	13	31	45	32
	75, 100	142	63	120	142	63	120	22	13	31	45	32

Double clevis bracket material: Cast iron
Surface treatment: Painted

Bore size (mm)	Stroke range (mm)	CZ	L	L ₁	N	RR
63	10 to 50	44	8	33.5	M10 x 1.5	14
	75, 100	44	8	33.5	M10 x 1.5	14
80	10 to 50	56	10	43.5	M12 x 1.75	18
	75, 100	56	10	43.5	M12 x 1.75	18
100	10 to 50	64	12	43.5	M12 x 1.75	22
	75, 100	64	12	43.5	M12 x 1.75	22

* For details about the rod end nut and accessory brackets, refer to page 23.
* Double clevis pin and retaining rings are included.

Standard
Large Bore Size
Long Stroke
Non-rotating Rod
Axial Piping
Anti-lateral Load
With End Lock
Water Resistant
With Auto Switch
Auto Switch
Made to Order

Series CQ2

Accessory Brackets

Single Knuckle Joint

I-G012, I-Z015A
I-G02, I-G03

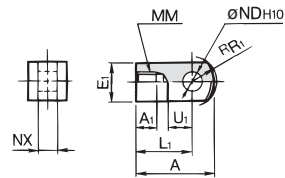

Material: Carbon steel
Surface treatment: Nickel plated

I-G04, I-G05
I-G08, I-G10

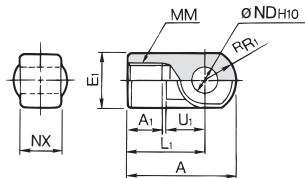

Material: Cast iron
Surface treatment: Nickel plated

(mm)

Part no.	Applicable bore size (mm)	A	A ₁	E ₁	L ₁	MM	R ₁	U ₁	ND _{H10}	NX
I-G012	12	21.5	6	□10	16	M5 x 0.8	6.3	7	5 ^{+0.048} ₀	5 ^{-0.2} _{-0.4}
I-Z015A	16	32	8	□12	25	M6 x 1	8.1	14	5 ^{+0.048} ₀	6.4 ^{-0.1} _{-0.3}
I-G02	20	34	8.5	□16	25	M8 x 1.25	10.3	11.5	8 ^{+0.058} ₀	8 ^{-0.2} _{-0.4}
I-G03	25	41	10.5	□20	30	M10 x 1.25	12.8	14	10 ^{+0.058} ₀	10 ^{-0.2} _{-0.4}
I-G04	32, 40	42	14	∅22	30	M14 x 1.5	12	14	10 ^{+0.058} ₀	18 ^{-0.3} _{-0.5}
I-G05	50, 63	56	18	∅28	40	M18 x 1.5	16	20	14 ^{+0.070} ₀	22 ^{-0.3} _{-0.5}
I-G08	80	71	21	∅38	50	M22 x 1.5	21	27	18 ^{+0.070} ₀	28 ^{-0.3} _{-0.5}
I-G10	100	79	21	∅44	55	M26 x 1.5	24	31	22 ^{+0.084} ₀	32 ^{-0.3} _{-0.5}

Double Knuckle Joint

Y-G012, Y-Z015A
Y-G02, Y-G03

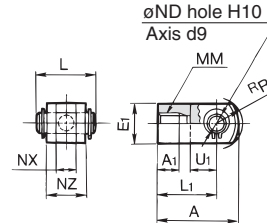

Material: Carbon steel
Surface treatment: Nickel plated

Y-G04, Y-G05
Y-G08, Y-G10

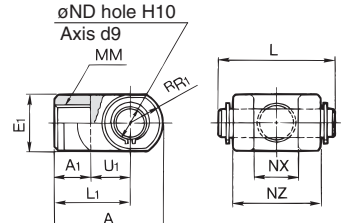

Material: Cast iron
Surface treatment: Nickel plated

(mm)

Part no.	Applicable bore size (mm)	A	A ₁	E ₁	L ₁	MM	R ₁	U ₁	ND _{H10}	NX	NZ	L	Applicable pin part no.
Y-G012	12	21.5	6	□10	16	M5 x 0.8	6.3	7	5 ^{+0.048} ₀	5 ^{+0.4} _{-0.2}	10	14.6	IY-G012
Y-Z015A	16	28	11	□12	21	M6 x 1	8.1	10	5 ^{+0.048} ₀	6.5 ^{+0.2} ₀	12	16.6	IY-J015
Y-G02	20	34	8.5	□16	25	M8 x 1.25	10.3	11.5	8 ^{+0.058} ₀	8 ^{+0.4} _{+0.2}	16	21	IY-G02
Y-G03	25	41	10.5	□20	30	M10 x 1.25	12.8	14	10 ^{+0.058} ₀	10 ^{+0.4} _{+0.2}	20	25.6	IY-G03
Y-G04	32, 40	42	16	∅22	30	M14 x 1.5	12	14	10 ^{+0.058} ₀	18 ^{+0.3} _{-0.3}	36	41.6	IY-G04
Y-G05	50, 63	56	20	∅28	40	M18 x 1.5	16	20	14 ^{+0.070} ₀	22 ^{+0.5} _{+0.3}	44	50.6	IY-G05
Y-G08	80	71	23	∅38	50	M22 x 1.5	21	27	18 ^{+0.070} ₀	28 ^{+0.5} _{+0.3}	56	64	IY-G08
Y-G10	100	79	24	∅44	55	M26 x 1.5	24	31	22 ^{+0.084} ₀	32 ^{+0.5} _{+0.3}	64	72	IY-G10

* Knuckle pin and retaining rings are included.

Knuckle Pin (Common with double clevis pin)

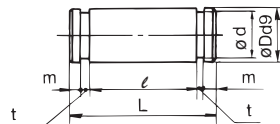

Material: Carbon steel
(mm)

Part no.	Applicable bore size (mm)	Dd9	L	d	l	m	t	Applicable retaining ring
IY-G012	12	5 ^{-0.030} _{-0.060}	14.6	4.8	10.2	1.5	0.7	Type C5 for axis
IY-J015	16	5 ^{-0.030} _{-0.060}	16.6	4.8	12.2	1.5	0.7	Type C5 for axis
IY-G02	20	8 ^{-0.040} _{-0.076}	21	7.6	16.2	1.5	0.9	Type C8 for axis
IY-G03	25	10 ^{-0.040} _{-0.076}	25.6	9.6	20.2	1.55	1.15	Type C10 for axis
IY-G04	32, 40	14 ^{-0.050} _{-0.093}	41.6	9.6	36.2	1.55	1.15	Type C10 for axis
IY-G05	50, 63	14 ^{-0.050} _{-0.093}	50.6	13.4	44.2	2.05	1.15	Type C14 for axis
IY-G08	80	18 ^{-0.050} _{-0.093}	64	17	56.2	2.55	1.35	Type C18 for axis
IY-G10	100	22 ^{-0.065} _{-0.117}	72	21	64.2	2.55	1.35	Type C22 for axis

* Type C retaining rings for axis are included.

Rod End Nut

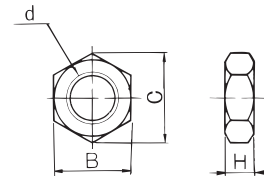

Material: Carbon steel
Surface treatment: Nickel plated
(mm)

Part no.	Applicable bore size (mm)	d	H	B	C
NTJ-015A	12	M5 x 0.8	4	8	9.2
NT-015A	16	M6 x 1	5	10	11.5
NT-02	20	M8 x 1.25	5	13	15.0
NT-03	25	M10 x 1.25	6	17	19.6
NT-04	32, 40	M14 x 1.5	8	22	25.4
NT-05	50, 63	M18 x 1.5	11	27	31.2
NT-08	80	M22 x 1.5	13	32	37.0
NT-10	100	M26 x 1.5	16	41	47.3

Simple Joint (CQ2): $\phi 32$ to $\phi 100$

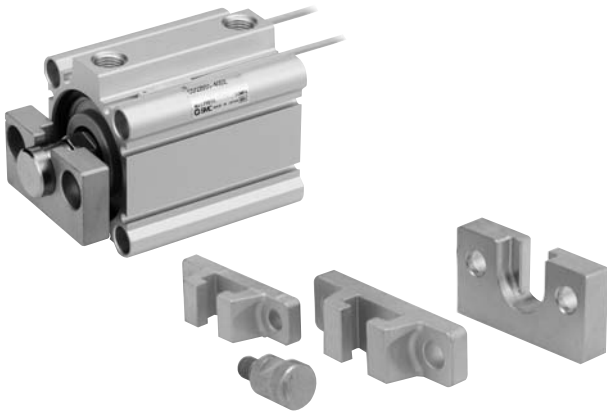

Type A Mounting Bracket

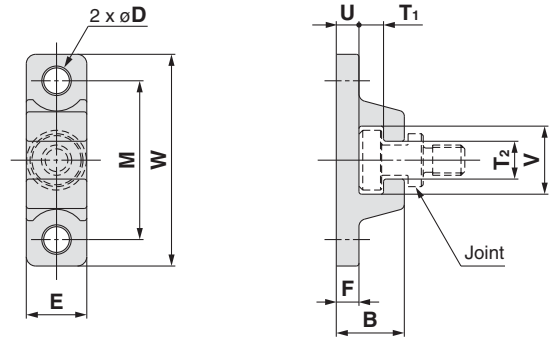

Material: Chromium molybdenum steel (Nickel plated) (mm)

Part no.	Bore size (mm)	B	D	E	F	M	T ₁	T ₂
YA-03	32, 40	18	6.8	16	6	42	6.5	10
YA-05	50, 63	20	9	20	8	50	6.5	12
YA-08	80	26	11	25	10	62	8.5	16
YA-10	100	31	14	30	12	76	10.5	18

Part no.	Bore size (mm)	U	V	W	Weight (g)
YA-03	32, 40	6	18	56	55
YA-05	50, 63	8	22	67	100
YA-08	80	10	28	83	195
YA-10	100	12	36	100	340

Joint/Mounting Bracket (Type A/B)/Part No.

YA - 03

• Applicable air cylinder bore size

03	For $\phi 32, \phi 40$
05	For $\phi 50, \phi 63$
08	For $\phi 80$
10	For $\phi 100$

• Mounting bracket

YA	Type A mounting bracket
YB	Type B mounting bracket
YU	Joint

Allowable Eccentricity (mm)

Bore size (mm)	32	40	50	63	80	100
Eccentricity tolerance	±1			±1.5		±2
Backlash	0.5					

<Ordering>

- Joints are not included with type A or B mounting brackets. Order them separately.

(Example)

- Bore size $\phi 40$ Part no.
- Type A mounting bracket YA-03
- Joint YU-03

Joint/Mounting Bracket (Type A/B)/Part No.

Bore size (mm)	Joint	Applicable mounting bracket	
		Type A mounting bracket	Type B mounting bracket
32, 40	YU-03	YA-03	YB-03
50, 63	YU-05	YA-05	YB-05
80	YU-08	YA-08	YB-08
100	YU-10	YA-10	YB-10

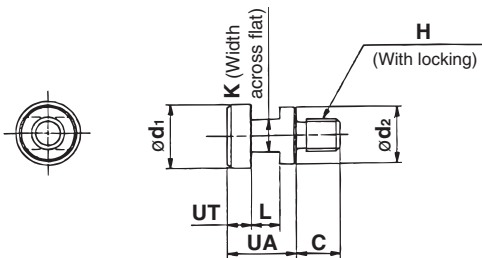

Material: Chromium molybdenum steel (Nickel plated) (mm)

Part no.	Applicable bore size (mm)	UA	C	d ₁	d ₂	H	K	L	UT	Weight (g)
YU-03	32, 40	17	11	15.8	14	M8 x 1.25	8	7	6	25
YU-05	50, 63	17	13	19.8	18	M10 x 1.5	10	7	6	40
YU-08	80	22	20	24.8	23	M16 x 2	13	9	8	90
YU-10	100	26	26	29.8	28	M20 x 2.5	14	11	10	160

Type B Mounting Bracket

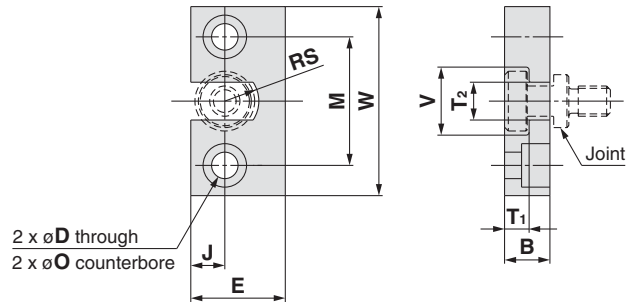

Material: Stainless steel (mm)

Part no.	Bore size (mm)	B	D	E	J	M	ϕO
YB-03	32, 40	12	7	25	9	34	11.5 depth 7.5
YB-05	50, 63	12	9	32	11	42	14.5 depth 8.5
YB-08	80	16	11	38	13	52	18 depth 12
YB-10	100	19	14	50	17	62	21 depth 14

Part no.	Bore size (mm)	T ₁	T ₂	V	W	RS	Weight (g)
YB-03	32, 40	6.5	10	18	50	9	80
YB-05	50, 63	6.5	12	22	60	11	120
YB-08	80	8.5	16	28	75	14	230
YB-10	100	10.5	18	36	90	18	455

Standard

Large Bore Size

Long Stroke

Non-rotating Rod

Axial Piping

Anti-lateral Load

With End Lock

Water Resistant

With Auto Switch

Auto Switch

Made to Order

Double Clevis Pivot Bracket

Bore size $\varnothing 12$ to $\varnothing 25$

Without auto switch

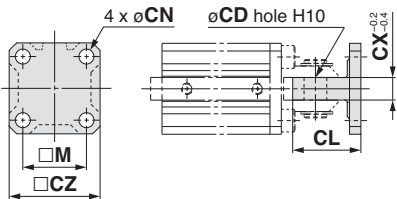
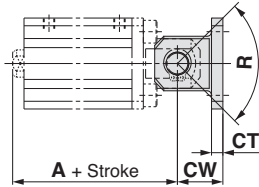

With auto switch

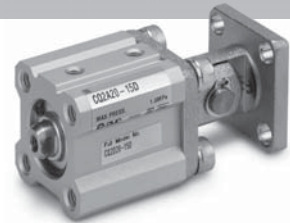
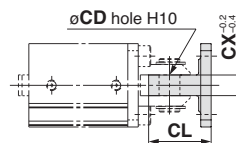
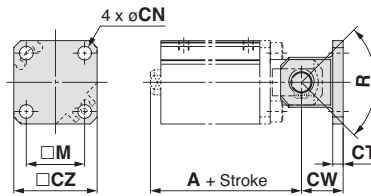

(mm)

Bracket part no.	Bore size	Stroke range	A		CW	CT	CL	CX	CD	M	CZ	R	CN	Hexagon socket head cap screw for mounting pivot bracket (Accessory)
			Without auto switch	With auto switch										
CQ-C012	12	5 to 30	34.5	45.5	14	4	19	5	5	15.5	25	100°	4.5	M4 x 10L
CQ-C016	16	5 to 30	37	49	15	4	21	6.5	5	20	28	100°	4.5	M4 x 10L
CQ-C020	20	5 to 50	42	54	18	5	27	8	8	25.5	35	80°	6.6	M6 x 12L
CQ-C025	25	5 to 50	47.5	57.5	20	5	30	10	10	28	40	90°	6.6	M6 x 12L

* The double clevis pin and retaining ring are not included.

Double clevis pivot bracket material: Carbon steel
Surface treatment: Nickel plated

Bore size $\varnothing 32$ to $\varnothing 100$

Without auto switch, With auto switch

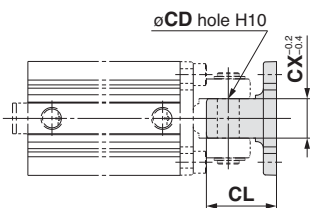
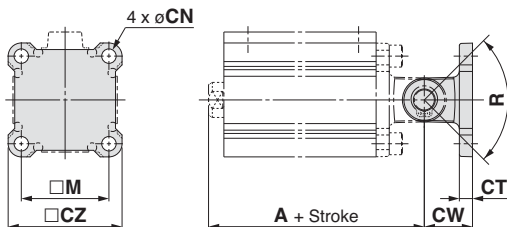

(mm)

Bracket part no.	Bore size	Stroke range	A		CW	CT	CL	CX	CD	M	CZ	R	CN	Hexagon socket head cap screw for mounting pivot bracket (Accessory)
			Without auto switch	With auto switch										
CQ-C032	32	5 to 50	50	60	20	5	30	18	10	34	45	80°	6.6	M6 x 12L
		75, 100	60											
CQ-C040	40	5 to 50	58.5	68.5	22	6	32	18	10	40	52	80°	6.6	M6 x 14L
		75, 100	68.5											
CQ-C050	50	10 to 50	66.5	76.5	28	7	42	22	14	50	64	80°	9	M8 x 16L
		75, 100	76.5											
CQ-C063	63	10 to 50	74	84	30	8	44	22	14	60	77	60°	11	M10 x 20L
		75, 100	84											
CQ-C080	80	10 to 50	91.5	101.5	38	10	56	28	18	77	98	70°	13.5	M12 x 25L
		75, 100	101.5											
CQ-C100	100	10 to 50	110	120	45	13	67	32	22	94	117	70°	13.5	M12 x 30L
		75, 100	120											

* The double clevis pin and retaining ring are not included.

Double clevis pivot bracket material: Cast iron
Surface treatment: Painted

Compact Cylinder: Standard Double Acting, Double Rod

Series CQ2W

ø12, ø16, ø20, ø25, ø32, ø40, ø50, ø63, ø80, ø100

How to Order

Without auto switch
ø12 to ø25

CQ2W **B** **20** - **30D**

Without auto switch
ø32 to ø100

CQ2W **B** **32** - **30D** **Z**

With auto switch

CDQ2W **B** **32** - **30D** **Z** - **M9BW**

With auto switch
(Built-in magnet)

Mounting

B	Through-hole (Standard)	L	Foot
A	Both ends tapped	LC	Compact foot
		F	Flange

- * Mounting brackets are shipped together, (but not assembled).
- * Cylinder mounting bolts are not included. Order them separately referring to "Mounting Bolt for (C/D)Q2WB" on pages 29 and 32.

Type

-	Pneumatic
H	Air-hydro ^{Note 1)}

Note 1) Bore sizes available for air-hydro type are ø20 to ø100.

Bore size

12	12 mm
16	16 mm
20	20 mm
25	25 mm
32	32 mm
40	40 mm
50	50 mm
63	63 mm
80	80 mm
100	100 mm

Port thread type

-	M thread	ø12 to ø25
	Rc	
TN	NPT	ø32 to ø100
TF	G	
F	Built-in one-touch fittings ^{Note 2)}	

Note 2) Bore sizes available with one-touch fittings are ø32 to ø63. Besides, it is not possible to use for air-hydro type.

Note 3) "TF" is not available for the air-hydro type.
* For cylinders without auto switch, M threads are compatible only for ø32-5 mm stroke.

Auto switch

- Without auto switch

* Refer to the below table for applicable auto switches.

Auto switch mounting groove

Z	ø12 to ø25	2 surfaces
	ø32 to ø100	4 surfaces

Number of auto switches

-	2 pcs.
S	1 pc.
n	"n" pcs.

Made to Order

Refer to the next page for details.

Body option

-	Standard (Rod end female thread)
C	With rubber bumper ^{Note 4)}
M	Rod end male thread

* Combination of body options ("CM") is available.

Note 4) Air-hydro type with rubber bumper is not available.

Action

D Double acting

Cylinder stroke (mm)

Refer to the next page for standard strokes.

Built-in Magnet Cylinder Model

If a built-in magnet cylinder without an auto switch is required, there is no need to enter the symbol for the auto switch.
(Example) CDQ2WL32-25DZ

Refer to pages 1263 to 1371 in Best Pneumatics No. 2 for further information on auto switches.

Applicable Auto Switches

Refer to the individual catalogue (ES20-201) for the D-P3DW type.

Type	Special function	Electrical entry	Indicator light	Wiring (Output)	Load voltage		Auto switch model		Lead wire length (m)					Pre-wired connector	Applicable load		
					DC	AC	Perpendicular	In-line	0.5 (-)	1 (M)	3 (L)	5 (Z)	None (N)				
Solid state auto switch	—	Grommet	Yes	3-wire (NPN)	24 V	5 V, 12 V	—	M9NV	M9N	●	●	●	○	—	○	Relay, PLC	
				3-wire (PNP)				M9PV	M9P	●	●	●	○	—	○		
				2-wire				M9BV	M9B	●	●	●	○	—	○		
				3-wire (NPN)				M9NWV	M9NW	●	●	●	○	—	○		
	3-wire (PNP)			M9PWV				M9PW	●	●	●	○	—	○			
	2-wire			M9BWW				M9BW	●	●	●	○	—	○			
	3-wire (NPN)			M9NAV **				M9NA **	○	○	●	○	—	○			
	3-wire (PNP)			M9PAV **				M9PA **	○	○	●	○	—	○			
	2-wire			M9BAV **				M9BA **	○	○	●	○	—	○			
	2-wire (Non-polar)			—				P3DW	●	—	●	●	—	○			
Reed auto switch	—	Grommet	Yes	3-wire (NPN equivalent)	24 V	5 V, 12 V, 100 V or less	—	A96V	A96	●	—	●	—	—	—	IC circuit	Relay, PLC
				2-wire				A93V	A93	●	—	●	—	—	—		
								A90V	A90	●	—	●	—	—	—		

* * Water resistant type auto switches can be mounted on the above models, but in such case SMC cannot guarantee water resistance. Consult with SMC regarding water resistant types with the above model numbers.

* Lead wire length symbols: 0.5 m - (Example) M9NW
1 m M (Example) M9NWM
3 m L (Example) M9NWL
5 m Z (Example) M9NWW

* Solid state auto switches marked with "○" are produced upon receipt of order.
* The D-P3DW□ type is available from ø32 to ø100 only.

* There are other applicable auto switches other than the listed above. For details, refer to page 199.

* For details about auto switches with pre-wired connector, refer to pages 1328 and 1329 in Best Pneumatics No. 2.

Series CQ2W

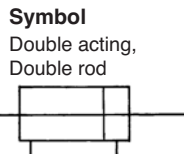
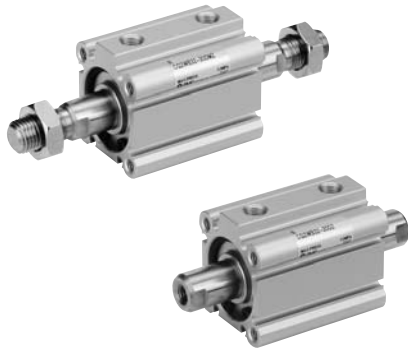

Made to Order
(For details, refer to pages 201 to 235.)

Symbol	Specifications
-XA□	Special rod end shape
-XB6	Heat resistant cylinder (-10 to 150°C) w/o auto switch only
-XB7	Heat resistant cylinder (-40 to 70°C) w/o auto switch only
-XB9	Low-speed cylinder (10 to 50 mm/s)
-XB10	Intermediate stroke (Exclusive body type)
-XB13	Low-speed cylinder (5 to 50 mm/s)
-XC2(A)	Rod end length, 10 mm increased (For foot and flange bracket)
-XC4	With heavy-duty scraper, ø40 to ø100 only
-XC6	Piston rod/Retaining ring/Rod end nut material: Stainless steel
-XC35	With coil scraper, ø32 to ø100 only
-XC36	With boss on rod side
-XC85	Grease for food processing equipment
-X144	Special port location, with auto switch ø12 to ø25 only
-X235	Special rod end for double rod cylinder
-X271	Fluororubber seals
-X293	Full length dimension is the same as Series CQ1W.
-X633	Intermediate stroke of double rod cylinder

Refer to pages 193 to 199 for the specifications of cylinders with autoswitches.

- Auto switch proper mounting position (detection at stroke end) and its mounting height
- Minimum stroke for auto switch mounting
- Operating range
- Auto switch mounting brackets/Part no.

Specifications

Pneumatic type

Bore size (mm)	12	16	20	25	32	40	50	63	80	100	
Action	Double acting, Double rod										
Fluid	Air										
Proof pressure	1.5 MPa										
Maximum operating pressure	1.0 MPa										
Minimum operating pressure	0.07 MPa		0.05 MPa								
Ambient and fluid temperature	Without auto switch: -10 to 70°C (No freezing) With auto switch: -10 to 60°C (No freezing)										
Lubrication	Not required (Non-lube)										
Piston speed	50 to 500 mm/s										
Allowable kinetic energy (J)	Standard	0.022	0.038	0.055	0.09	0.15	0.26	0.46	0.77	1.36	2.27
	With rubber bumper	0.043	0.075	0.11	0.18	0.29	0.52	0.91	1.54	2.71	4.54
Stroke length tolerance	+1.0 mm (Note) 0										

Note) Stroke length tolerance does not include the amount of bumper change.

Air-hydro type

Bore size (mm)	20	25	32	40	50	63	80	100
Action	Double acting, Double rod							
Fluid	Turbine oil (Note)							
Proof pressure	1.5 MPa							
Maximum operating pressure	1.0 MPa							
Minimum operating pressure	0.18 MPa		0.1 MPa					
Ambient and fluid temperature	5 to 60°C							
Piston speed	5 to 50 mm/s							
Cushion	None							
Stroke length tolerance	+1.0 mm 0							

Note) Refer to "Handling Precautions for SMC Products" (M-E03-3) for Actuator Precautions (5).

Standard Strokes

Pneumatic type (Non-lube) (mm)

Bore size	Standard stroke
12, 16	5, 10, 15, 20, 25, 30
20, 25	5, 10, 15, 20, 25, 30 35, 40, 45, 50
32, 40	5, 10, 15, 20, 25, 30 35, 40, 45, 50, 75, 100
50, 63	10, 15, 20, 25, 30
80, 100	35, 40, 45, 50, 75, 100

Air-hydro type (mm)

Bore size	Standard stroke
20, 25	5, 10, 15, 20, 25, 30 35, 40, 45, 50
32, 40	5, 10, 15, 20, 25, 30 35, 40, 45, 50, 75, 100
50, 63	10, 15, 20, 25, 30
80, 100	35, 40, 45, 50, 75, 100

Manufacture of Intermediate Strokes

Type	A spacer is installed in the standard stroke body. (5 mm intervals)	A spacer is installed in the standard stroke body. (1 mm intervals)	Exclusive body (-XB10)			
Part no.	Refer to "How to Order" for the standard model number. (P. 26)	Suffix "-X633" (P. 233) to the end of standard model number. (P. 26)	Suffix "-XB10" to the end of standard model number. (P. 26)			
Description	Strokes in 5 mm intervals are available by installing a spacer in the standard stroke cylinder.	Strokes in 1 mm intervals are available by installing a spacer in the standard stroke cylinder.	Strokes in 1 mm intervals are available by using an exclusive body with the specified stroke.			
Stroke range	Bore size	Stroke range	Bore size	Stroke range	Bore size	Stroke range
	—	—	12, 16	6 to 29	12, 16	6 to 29
	—	—	20, 25	6 to 49	20, 25	6 to 49
	32 to 100	55 to 95	32, 40	6 to 99	32, 40	6 to 99
Example	Part no.: CQ2WB50-65DZ CQ2WB50-75DZ with 10 mm width spacer inside The B dimension is 125.5 mm.		Part no.: CQ2WB50-72DZ-X633 CQ2WB50-75DZ with 3 mm width spacer inside The B dimension is 125.5 mm.		Part no.: CQ2WB50-65DZ-XB10 Makes 65 mm stroke tube. The B dimension is 115.5 mm.	

- Except air-hydro type
- In the case of spacer type, intermediate strokes with bumper for ø40 to ø100, "-X633" is not available.
- In the case of exclusive body type with ø32 to ø100 (-XB10) with the stroke length exceeding 50 mm, reference values of the longitudinal dimension will be changed.
Calculate length dimensions by deducting from those of 75 or 100 mm stroke models.

Type

Bore size (mm)		12	16	20	25	32	40	50	63	80	100		
Pneumatic	Mounting	Through-hole (Standard)	●	●	●	●	●	●	●	●	●		
		Both ends tapped	●	●	●	●	●	●	●	●	●		
	Built-in magnet		●	●	●	●	●	●	●	●	●		
	Piping	Pipe thread	—	M5	M5	M5	M5	Note 1) M5 Rc1/8	Rc1/8	Rc1/4	Rc1/4	Rc3/8	Rc3/8
			TN	—	—	—	—	NPT1/8	NPT1/8	NPT1/4	NPT1/4	NPT3/8	NPT3/8
		TF	—	—	—	—	G1/8	G1/8	G1/4	G1/4	G3/8	G3/8	
		Built-in one-touch fittings Note 3)	—	—	—	—	ø6/4 Note 2)	ø6/4	ø8/6	ø8/6	—	—	
	Rod end male thread		●	●	●	●	●	●	●	●	●	●	
	With rubber bumper		●	●	●	●	●	●	●	●	●	●	
	Air-hydro	Mounting	Through-hole (Standard)	—	—	●	●	●	●	●	●	●	
Both ends tapped			—	—	●	●	●	●	●	●	●		
Built-in magnet		—	—	●	●	●	●	●	●	●			
Piping		Pipe thread	—	—	—	M5	M5	Note 1) M5 Rc1/8	Rc1/8	Rc1/4	Rc1/4	Rc3/8	Rc3/8
			TN	—	—	—	—	NPT1/8	NPT1/8	NPT1/4	NPT1/4	NPT3/8	NPT3/8
Rod end male thread		—	—	●	●	●	●	●	●	●	●		

Note 1) ø32 without auto switch: M5 is used for 5 mm strokepiping dimension.
Thus, do not enter a symbol for the port thread type.

Note 2) The dimension of the ø32-5 mm stroke with built-in one-touch fittings is the same as that of the 10 mm stroke cylinder tube.

Note 3) One-touch fittings cannot be replaced.

Mounting Brackets/Part No.

Bore size (mm)	Model	Foot Note 4)	Compact Foot Note 4)	Flange
12	Without switch	CQ2□□-□D	CQ-L012	CQ-LC012
	With switch	CQ2□□-□DZ	CQ-LZ12	CQ-LCZ12
16	Without switch	CQ2□□-□D	CQ-L016	CQ-LC016
	With switch	CQ2□□-□DZ	CQ-LZ16	CQ-LCZ16
20	Without switch	CQ2□□-□D	CQ-L020	CQ-LC020
	With switch	CQ2□□-□DZ	CQ-LZ20	CQ-LCZ20
25	Without switch	CQ2□□-□D	CQ-L025	CQ-LC025
	With switch	CQ2□□-□DZ	CQ-LZ25	CQ-LCZ25
32	CQ2□□-□DZ	CQ-L032	CQ-LC032	CQ-F032
40	CQ2□□-□DZ	CQ-L040	CQ-LC040	CQ-F040
50	CQ2□□-□DZ	CQ-L050	CQ-LC050	CQ-F050
63	CQ2□□-□DZ	CQ-L063	CQ-LC063	CQ-F063
80	CQ2□□-□DZ	CQ-L080	CQ-LC080	CQ-F080
100	CQ2□□-□DZ	CQ-L100	CQ-LC100	CQ-F100

Note 4) When ordering a foot and compact foot brackets, the required quantity will be different depending on the bore size.

ø12 to ø25:

- Without switch: Order 2 pieces per cylinder.
- With switch: Order 1 piece per cylinder. (Part number for a set of 2 foot brackets)

ø32 to ø100:

- Order 2 pieces per cylinder.

Note 5) Parts belonging to each bracket are as follows.

Foot, Compact foot, Flange: Body mounting bolts

Retaining Ring Installation/Removal

⚠ Caution

- For installation and removal, use an appropriate pair of pliers (tool for installing a type C retaining ring).
- Even if a proper plier (tool for installing a type C retaining ring) is used, it is likely to inflict damage to a human body or peripheral equipment, as a retaining ring may be flown out of the tip of a plier (tool for installing a type C retaining ring). Be much careful with the popping of a retaining ring. Besides, be certain that a retaining ring is placed firmly into the groove of rod cover before supplying air at the time of installment.

Mounting

⚠ Warning

Do not apply reverse torque to the piston rods sticking out from both sides of this cylinder at the same time. The torque makes connection threads inside loosen, which may cause an accident or malfunction.

Install or remove loads while the piston rod width across flat is secured. Do not fix the other side of the piston rod width across flat and apply reverse torque.

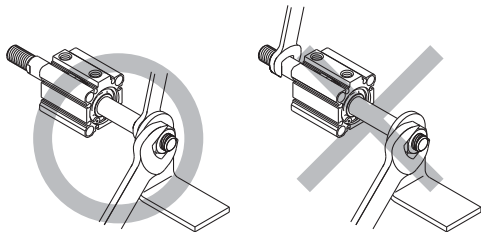

Allowable Lateral Load at Rod End

Without Auto Switch

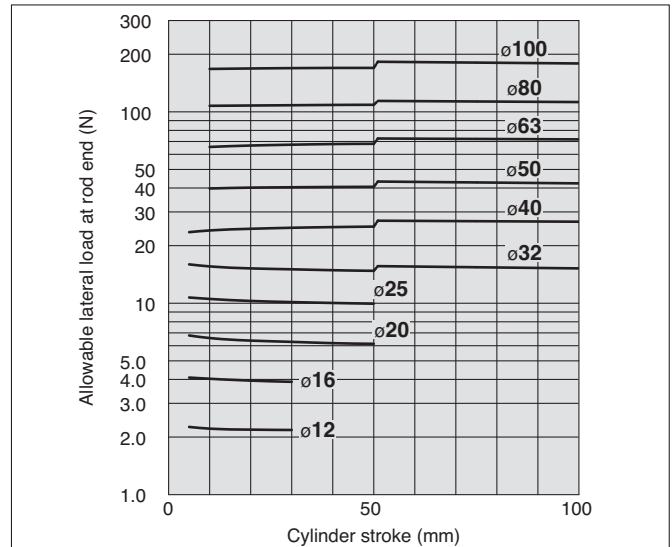

With Auto Switch

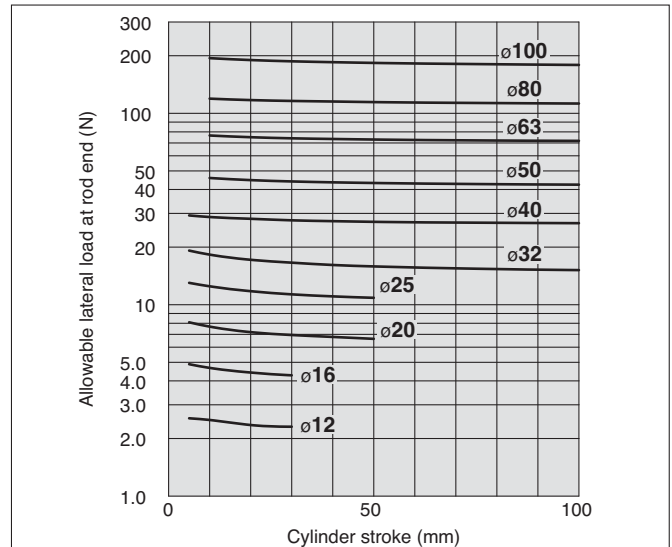

Standard

Large Bore Size

Long Stroke

Non-rotating Rod

Axial Piping

Anti-lateral Load

With End Lock

Water Resistant

With Auto Switch

Auto Switch

Made to Order

Series CQ2W

Theoretical Output

Bore size (mm)	Operating pressure (MPa)		
	0.3	0.5	0.7
12	25	42	59
16	45	75	106
20	71	118	165
25	113	189	264
32	181	302	422
40	317	528	739
50	495	825	1150
63	841	1400	1960
80	1360	2270	3170
100	2140	3570	5000

Weight

Bore size (mm)	Cylinder stroke (mm)											
	5	10	15	20	25	30	35	40	45	50	75	100
12	42	49	56	63	70	77	—	—	—	—	—	—
16	59	68	77	86	95	104	—	—	—	—	—	—
20	89	104	119	134	149	164	179	194	209	224	—	—
25	119	136	153	170	187	204	221	238	255	272	—	—
32	185	212	235	257	280	303	326	349	372	395	555	670
40	279	308	337	367	396	426	455	484	514	543	749	896
50	—	497	538	580	622	664	705	747	789	830	1122	1331
63	—	646	682	718	754	790	826	862	899	935	1187	1368
80	—	1149	1225	1302	1378	1455	1531	1608	1684	1760	2296	2678
100	—	1960	2068	2177	2286	2394	2503	2612	2720	2829	3589	4132

Additional Weight

Bore size (mm)	12	16	20	25	32	40	50	63	80	100
Both ends tapped	2	2	6	6	6	6	6	19	45	45
Rod end male thread	3	6	12	24	52	54	106	106	240	350
Nut	2	4	8	16	34	34	64	64	98	232
With rubber bumper	0	0	-2	-2	-3	-7	-12	-20	-34	-57
Built-in one-touch fittings	—	—	—	—	12	12	21	21	—	—
Foot (Including mounting bolts)	57	71	170	195	158	170	267	342	722	1107
Compact Foot (Including mounting bolts)	41	51	121	140	99	114	177	241	501	770
Flange (Including mounting bolts)	57	69	139	161	180	214	373	559	1056	1365

Calculation: (Example) **CQ2WF32-20DCMZ**

- Basic weight: CQ2WB32-20DZ 257 g
 - Additional weight: Both ends tapped 6 g
 - Rod end male thread 86 g
 - With rubber bumper -3 g
 - Flange 180 g
- 526 g

Mounting Bolt for CQ2WB/Without Auto Switch

Mounting method: Mounting bolt for through-hole mounting of the CQ2WB is available as an option. Refer to the following for ordering procedures. Order the actual number of bolts that will be used.

Example) CQ-M3 x 35L 4 pcs.

Material: Chromium molybdenum steel
Surface treatment: Zinc chromated

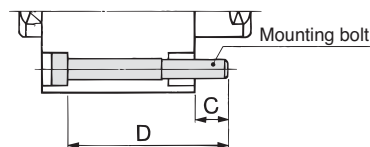

Cylinder model	C	D	Mounting bolt part no.
CQ2WB12-5D	8.3	35	CQ-M3 x 35L
-10D		40	x 40L
-15D		45	x 45L
-20D		50	x 50L
-25D		55	x 55L
-30D		60	x 60L
CQ2WB16-5D	7.5	35	CQ-M3 x 35L
-10D		40	x 40L
-15D		45	x 45L
-20D		50	x 50L
-25D		55	x 55L
-30D		60	x 60L
CQ2WB20-5D	6	30	CQ-M5 x 30L
-10D		35	x 35L
-15D		40	x 40L
-20D		45	x 45L
-25D		50	x 50L
-30D		55	x 55L
-35D		60	x 60L
-40D		65	x 65L
-45D		70	x 70L
-50D		75	x 75L
CQ2WB25-5D	8	35	CQ-M5 x 35L
-10D		40	x 40L
-15D		45	x 45L
-20D		50	x 50L
-25D		55	x 55L
-30D		60	x 60L
-35D		65	x 65L
-40D		70	x 70L
-45D		75	x 75L
-50D		80	x 80L

Cylinder model	C	D	Mounting bolt part no.
CQ2WB32-5DZ	6.5	35	CQ-M5 x 35L
-10DZ		40	x 40L
-15DZ		45	x 45L
-20DZ		50	x 50L
-25DZ		55	x 55L
-30DZ		60	x 60L
-35DZ		65	x 65L
-40DZ		70	x 70L
-45DZ		75	x 75L
-50DZ		80	x 80L
-75DZ	115	x 115L	
-100DZ	140	x 140L	
CQ2WB40-5DZ	7	45	CQ-M5 x 45L
-10DZ		50	x 50L
-15DZ		55	x 55L
-20DZ		60	x 60L
-25DZ		65	x 65L
-30DZ		70	x 70L
-35DZ		75	x 75L
-40DZ		80	x 80L
-45DZ		85	x 85L
-50DZ		90	x 90L
-75DZ	125	x 125L	
-100DZ	150	x 150L	
CQ2WB50-10DZ	12.5	55	CQ-M6 x 55L
-15DZ		60	x 60L
-20DZ		65	x 65L
-25DZ		70	x 70L
-30DZ		75	x 75L
-35DZ		80	x 80L
-40DZ		85	x 85L
-45DZ		90	x 90L
-50DZ		95	x 95L
-75DZ		130	x 130L
-100DZ	155	x 155L	

Cylinder model	C	D	Mounting bolt part no.
CQ2WB63-10DZ	13.5	55	CQ-M8 x 55L
-15DZ		60	x 60L
-20DZ		65	x 65L
-25DZ		70	x 70L
-30DZ		75	x 75L
-35DZ		80	x 80L
-40DZ		85	x 85L
-45DZ		90	x 90L
-50DZ		95	x 95L
-75DZ		130	x 130L
-100DZ	155	x 155L	
CQ2WB80-10DZ	12.5	60	CQ-M10 x 60L
-15DZ		65	x 65L
-20DZ		70	x 70L
-25DZ		75	x 75L
-30DZ		80	x 80L
-35DZ		85	x 85L
-40DZ		90	x 90L
-45DZ		95	x 95L
-50DZ		100	x 100L
-75DZ		135	x 135L
-100DZ	160	x 160L	
CQ2WB100-10DZ	13	70	CQ-M10 x 70L
-15DZ		75	x 75L
-20DZ		80	x 80L
-25DZ		85	x 85L
-30DZ		90	x 90L
-35DZ		95	x 95L
-40DZ		100	x 100L
-45DZ		105	x 105L
-50DZ		110	x 110L
-75DZ		145	x 145L
-100DZ	170	x 170L	

Construction

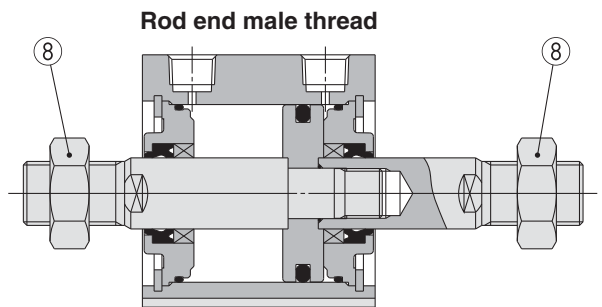
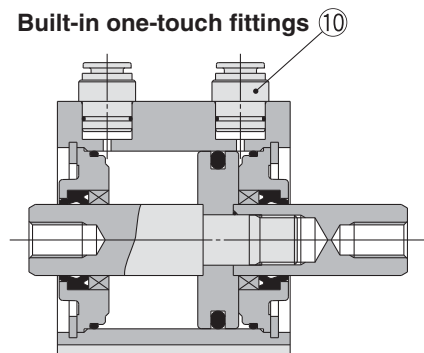
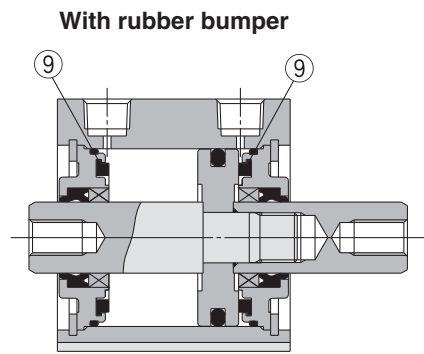
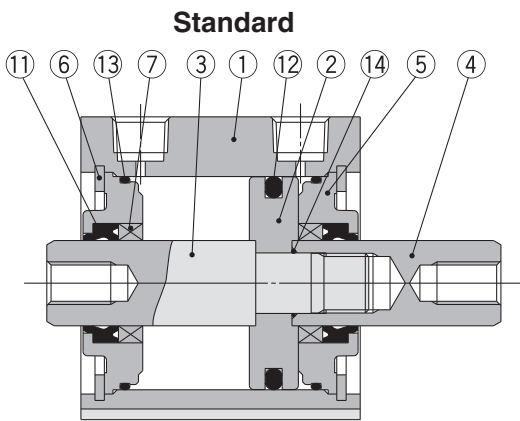

Component Parts

No.	Description	Material	Note
1	Cylinder tube	Aluminum alloy	Hard anodised
2	Piston	Aluminum alloy	Chromated
3	Piston rod A	Stainless steel	ø12 to ø25
		Carbon steel	ø32 to ø100, Hard chrome plated
4	Piston rod B	Stainless steel	ø12 to ø25
		Carbon steel	ø32 to ø100, Hard chrome plated
5	Collar	Aluminum alloy	ø12 to ø40, Anodised
		Aluminum alloy casted	ø50 to ø100, Chromated, Painted
6	Retaining ring	Carbon tool steel	Phosphate coated
7	Bushing	Bearing alloy	For ø50 or more only
8	Rod end nut	Carbon steel	Nickel plated
9	Bumper	Urethane	
10	One-touch fitting	—	ø32 to ø63
11*	Rod seal	NBR	
12*	Piston seal	NBR	
13*	Tube gasket	NBR	
14	Piston gasket	NBR	

Replacement Parts/Seal Kit (Pneumatic type)

Bore size (mm)	Kit no.	Contents
12	CQ2WB12-PS	Kits include items ⑪, ⑫, ⑬ from the table.
16	CQ2WB16-PS	
20	CQ2WB20-PS	
25	CQ2WB25-PS	
32	CQ2WB32-PS	
40	CQ2WB40-PS	
50	CQ2WB50-PS	
63	CQ2WB63-PS	
80	CQ2WB80-PS	
100	CQ2WB100-PS	

* Seal kit includes ⑪, ⑫, ⑬. Order the seal kit, based on each bore size.
* Since the seal kit does not include a grease pack, order it separately.
Grease pack part no.: GR-S-010 (10 g)

Replacement Parts/Seal Kit (Air-hydro type)

Bore size (mm)	Kit no.	Contents
20	CQ2WBH20-PS	Kits include items ⑪, ⑫, ⑬ from the table.
25	CQ2WBH25-PS	
32	CQ2WBH32-PS	
40	CQ2WBH40-PS	
50	CQ2WBH50-PS	
63	CQ2WBH63-PS	
80	CQ2WBH80-PS	
100	CQ2WBH100-PS	

* Seal kit includes ⑪, ⑫, ⑬. Order the seal kit, based on each bore size.
* Since the seal kit does not include a grease pack, order it separately.
Grease pack part no.: GR-S-010 (10 g)

Copper and Fluorine-free Series (For CRT Manufacturing Process)

20 — CQ2WB Bore size — Stroke D(C)(M)(Z)
 Copper and fluorine-free series
 ø12, ø16, ø20, ø25, ø32
 ø40, ø50, ø63, ø80, ø100

For preventing the influence of copper ions or halogen ions during CRT manufacturing processes, copper and fluorine materials are not used in the component parts.

Specifications

Bore size (mm)	12	16	20	25	32	40	50	63	80	100
Action	Double acting, Double rod									
Proof pressure	1.5 MPa									
Max. operating pressure	1.0 MPa									
Rubber bumper	None									
Piping	Pipe thread									
Piston speed	50 to 500 mm/s									
Mounting	Through-hole									
Auto switch	Mountable									

Standard
Large Bore Size
Long Stroke
Non-rotating Rod
Axial Piping
Anti-lateral Load
With End Lock
Water Resistant
With Auto Switch
Auto Switch
Made to Order

Standard: Double Acting, Double Rod Series **CDQ2W** With Auto Switch



Refer to the below pages for further information on auto switches.

Auto switch proper mounting position and its mounting height	P.193 to 199
Minimum stroke for auto switch mounting	
Operating range	
Auto switch mounting brackets/Part no.	

Weight

Weight (g)

Bore size (mm)	Cylinder stroke (mm)											
	5	10	15	20	25	30	35	40	45	50	75	100
12	50	58	65	73	80	87	—	—	—	—	—	—
16	77	87	96	106	115	125	—	—	—	—	—	—
20	120	136	151	166	182	197	212	228	243	258	—	—
25	170	185	201	216	232	247	263	279	294	310	—	—
32	238	260	283	306	329	352	375	398	421	444	558	673
40	353	383	412	442	471	500	530	559	589	618	765	912
50	—	609	645	681	716	752	788	823	859	895	1073	1252
63	—	798	840	882	924	966	1008	1051	1093	1135	1346	1556
80	—	1393	1469	1546	1622	1699	1775	1851	1928	2004	2387	2769
100	—	2334	2443	2551	2660	2769	2877	2986	3094	3203	3746	4289

Additional Weight (g)

Bore size (mm)	12	16	20	25	32	40	50	63	80	100
Both ends tapped	1	1	3	3	6	6	6	19	45	45
Rod end male thread	Male thread	3	6	12	24	52	54	106	106	240
	Nut	2	4	8	16	34	34	64	64	98
With rubber bumper	0	0	-2	-2	-3	-7	-12	-19	-34	-54
Built-in one-touch fittings	—	—	—	—	12	12	21	21	—	—
Foot (Including mounting bolts)	52	65	153	177	158	170	267	342	722	1107
Compact Foot (Including mounting bolts)	32	40	97	116	99	114	177	241	501	770
Flange (Including mounting bolts)	54	67	131	153	180	214	373	559	1056	1365

Calculation: (Example) **CDQ2WF32-20DCMZ**

• Basic weight: CDQ2WB32-20DZ	306 g	Add each weight of auto switches when auto switches are mounted.
• Additional weight: Both ends tapped	6 g	
Rod end male thread	86 g	
With rubber bumper	-3 g	
Rod flange	180 g	
	575 g	

Construction

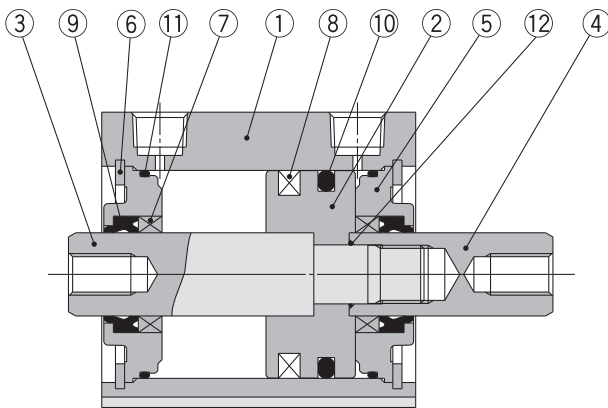

Component Parts

No.	Description	Material	Note
1	Cylinder tube	Aluminum alloy	Hard anodised
2	Piston	Aluminum alloy	Chromated
3	Piston rod A	Stainless steel	ø12 to ø25
		Carbon steel	ø32 to ø100, Hard chrome plated
4	Piston rod B	Stainless steel	ø12 to ø25
		Carbon steel	ø32 to ø100, Hard chrome plated
5	Collar	Aluminum alloy	ø12 to ø40, Anodised
		Aluminum alloy casted	ø50 to ø100, Chromated, Painted
6	Retaining ring	Carbon tool steel	Phosphate coated
7	Bushing	Bearing alloy	For ø50 or more only
8	Magnet	—	—
9*	Rod seal	NBR	
10*	Piston seal	NBR	
11*	Tube gasket	NBR	
12	Piston gasket	NBR	

Replacement Parts/Seal Kit (Pneumatic type)

Bore size (mm)	Kit no.	Contents
12	CQ2WB12-PS	Kits include items ⑨, ⑩, ⑪ from the table.
16	CQ2WB16-PS	
20	CQ2WB20-PS	
25	CQ2WB25-PS	
32	CQ2WB32-PS	
40	CQ2WB40-PS	
50	CQ2WB50-PS	
63	CQ2WB63-PS	
80	CQ2WB80-PS	
100	CQ2WB100-PS	

* Seal kit includes ⑨, ⑩, ⑪. Order the seal kit, based on each bore size.
* Since the seal kit does not include a grease pack, order it separately.
Grease pack part no.: GR-S-010 (10 g)

Replacement Parts/Seal Kit (Air-hydro type)

Bore size (mm)	Kit no.	Contents
20	CQ2WBH20-PS	Kits include items ⑨, ⑩, ⑪ from the table.
25	CQ2WBH25-PS	
32	CQ2WBH32-PS	
40	CQ2WBH40-PS	
50	CQ2WBH50-PS	
63	CQ2WBH63-PS	
80	CQ2WBH80-PS	
100	CQ2WBH100-PS	

* Seal kit includes ⑨, ⑩, ⑪. Order the seal kit, based on each bore size.
* Since the seal kit does not include a grease pack, order it separately.
Grease pack part no.: GR-S-010 (10 g)

Mounting Bolt for CDQ2WB/With Auto Switch

Mounting method: Mounting bolt for through-hole mounting of the CDQ2WB is available as an option. Refer to the following for ordering procedures. Order the actual number of bolts that will be used.

Example) CQ-M3 x 40L 2 pcs.

Material: Chromium molybdenum steel
Surface treatment: Zinc chromated

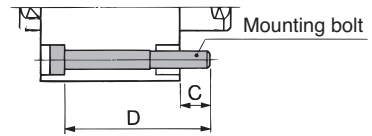

Cylinder model	C	D	Mounting bolt part no.
CDQ2WB12-5DCZ	6.1	40	CQ-M3 x 40L
-10DCZ		45	x 45L
-15DCZ		50	x 50L
-20DCZ		55	x 55L
-25DCZ		60	x 60L
-30DCZ		65	x 65L
CDQ2WB16-5DZ	7.5	45	CQ-M3 x 45L
-10DZ		50	x 50L
-15DZ		55	x 55L
-20DZ		60	x 60L
-25DZ		65	x 65L
-30DZ		70	x 70L
CDQ2WB20-5DZ	9	45	CQ-M5 x 45L
-10DZ		50	x 50L
-15DZ		55	x 55L
-20DZ		60	x 60L
-25DZ		65	x 65L
-30DZ		70	x 70L
-35DZ	75	x 75L	
-40DZ	80	x 80L	
-45DZ	85	x 85L	
-50DZ	90	x 90L	
CDQ2WB25-5DZ	8	45	CQ-M5 x 45L
-10DZ		50	x 50L
-15DZ		55	x 55L
-20DZ		60	x 60L
-25DZ		65	x 65L
-30DZ		70	x 70L
-35DZ	75	x 75L	
-40DZ	80	x 80L	
-45DZ	85	x 85L	
-50DZ	90	x 90L	

Cylinder model	C	D	Mounting bolt part no.
CDQ2WB32-5DZ	6.5	45	CQ-M5 x 45L
-10DZ		50	x 50L
-15DZ		55	x 55L
-20DZ		60	x 60L
-25DZ		65	x 65L
-30DZ		70	x 70L
-35DZ	75	x 75L	
-40DZ	80	x 80L	
-45DZ	85	x 85L	
-50DZ	90	x 90L	
-75DZ	115	x 115L	
-100DZ	140	x 140L	
CDQ2WB40-5DZ	7	55	CQ-M5 x 55L
-10DZ		60	x 60L
-15DZ		65	x 65L
-20DZ		70	x 70L
-25DZ		75	x 75L
-30DZ		80	x 80L
-35DZ	85	x 85L	
-40DZ	90	x 90L	
-45DZ	95	x 95L	
-50DZ	100	x 100L	
-75DZ	125	x 125L	
-100DZ	150	x 150L	
CDQ2WB50-10DZ	12.5	65	CQ-M6 x 65L
-15DZ		70	x 70L
-20DZ		75	x 75L
-25DZ		80	x 80L
-30DZ		85	x 85L
-35DZ		90	x 90L
-40DZ	95	x 95L	
-45DZ	100	x 100L	
-50DZ	105	x 105L	
-75DZ	130	x 130L	
-100DZ	155	x 155L	

Cylinder model	C	D	Mounting bolt part no.
CDQ2WB63-10DZ	13.5	65	CQ-M8 x 65L
-15DZ		70	x 70L
-20DZ		75	x 75L
-25DZ		80	x 80L
-30DZ		85	x 85L
-35DZ		90	x 90L
-40DZ	95	x 95L	
-45DZ	100	x 100L	
-50DZ	105	x 105L	
-75DZ	130	x 130L	
-100DZ	155	x 155L	
CDQ2WB80-10DZ	12.5	70	CQ-M10 x 70L
-15DZ		75	x 75L
-20DZ		80	x 80L
-25DZ		85	x 85L
-30DZ		90	x 90L
-35DZ		95	x 95L
-40DZ	100	x 100L	
-45DZ	105	x 105L	
-50DZ	110	x 110L	
-75DZ	135	x 135L	
-100DZ	160	x 160L	
CDQ2WB100-10DZ	13	80	CQ-M10 x 80L
-15DZ		85	x 85L
-20DZ		90	x 90L
-25DZ		95	x 95L
-30DZ		100	x 100L
-35DZ		105	x 105L
-40DZ	110	x 110L	
-45DZ	115	x 115L	
-50DZ	120	x 120L	
-75DZ	145	x 145L	
-100DZ	170	x 170L	

- Standard
- Large Bore Size
- Long Stroke
- Non-rotating Rod
- Axial Piping
- Anti-lateral Load
- With End Lock
- Water Resistant
- With Auto Switch
- Auto Switch
- Made to Order

Series CQ2W

Dimensions

Ø12 to Ø25/Without Auto Switch

Both ends tapped: CQ2WA

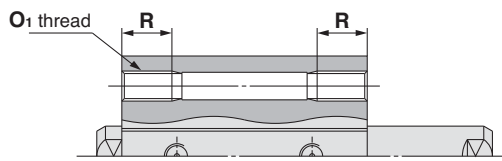

Both Ends Tapped

Bore size (mm)	O ₁	R
12	M4 x 0.7	7
16	M4 x 0.7	7
20	M6 x 1.0	10
25	M6 x 1.0	10

Standard (Through-hole): CQ2WB

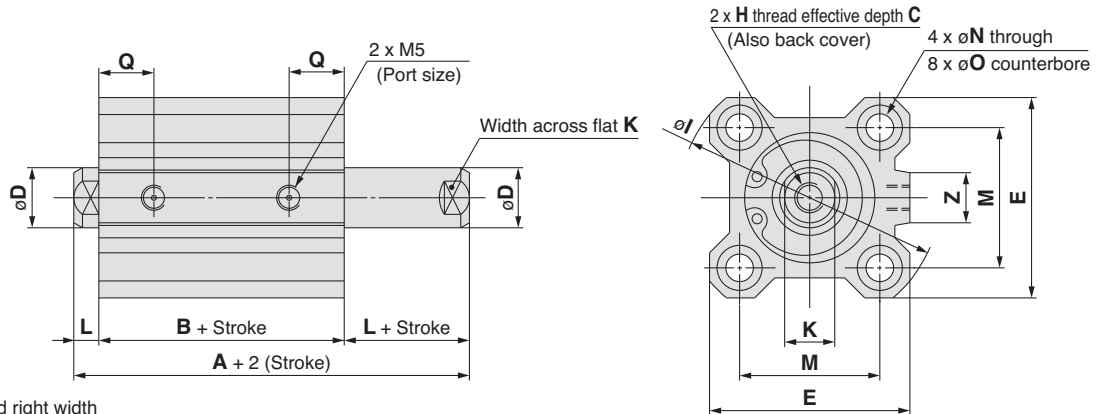

Note 1) The positions of left and right width across flats are not constant.

Rod end male thread

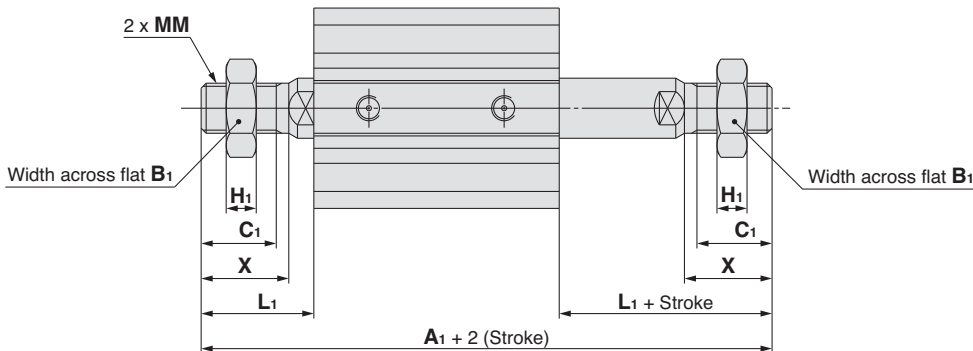

Rod End Male Thread

Bore size (mm)	A ₁	B ₁	C ₁	H ₁	L ₁	MM	X
12	53.2	8	9	4	14	M5 x 0.8	10.5
16	57	10	10	5	15.5	M6 x 1.0	12
20	63	13	12	5	18.5	M8 x 1.25	14
25	74	17	15	6	22.5	M10 x 1.25	17.5

Standard

Bore size (mm)	Stroke range (mm)	A	B	C	D	E	H	I	K	L	M	N	O	Q	Z
12	5 to 30	32.2	25.2	6	6	25	M3 x 0.5	32	5	3.5	15.5	3.5	6.5 depth 3.5	10	—
16	5 to 30	33	26	8	8	29	M4 x 0.7	38	6	3.5	20	3.5	6.5 depth 3.5	10	10
20	5 to 50	35	26	7	10	36	M5 x 0.8	47	8	4.5	25.5	5.5	9 depth 7	8	10
25	5 to 50	39	29	12	12	40	M6 x 1.0	52	10	5	28	5.5	9 depth 7	9	10

Note 2) The external dimensions with rubber bumper are same as those of the standard, as shown above.

* For details about the rod end nut and accessory brackets, refer to page 23.

Foot: CQ2WL

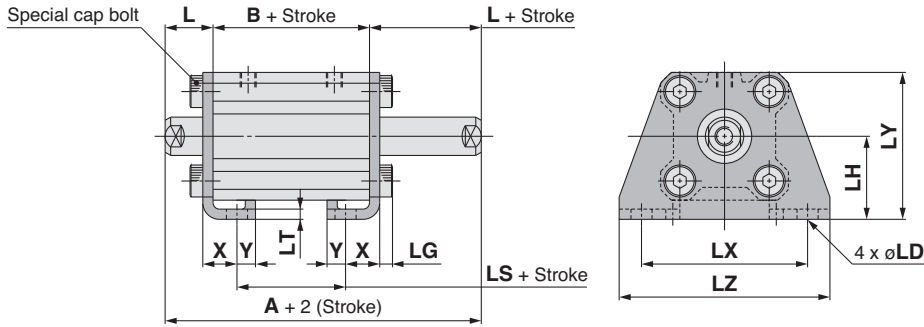

Note) The positions of left and right width across flats are not constant.

Rod end male thread

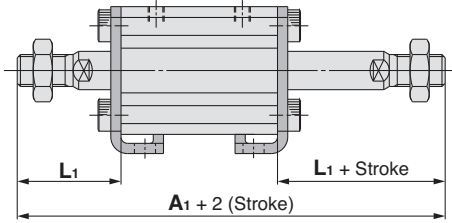

Rod End Male Thread (mm)

Bore size (mm)	A ₁	L ₁
12	73.2	24
16	77	25.5
20	83	28.5
25	94	32.5

Foot

Bore size (mm)	Stroke range (mm)	A	B	L	LD	LG	LH	LS	LT	LX	LY	LZ	X	Y
12	5 to 30	52.2	25.2	13.5	4.5	2.8	17	13.2	2	34	29.5	44	8	4.5
16	5 to 30	53	26	13.5	4.5	2.8	19	14	2	38	33.5	48	8	5
20	5 to 50	55	26	14.5	6.6	4	24	14	3.2	48	42	62	9.2	5.8
25	5 to 50	59	29	15	6.6	4	26	14	3.2	52	46	66	10.7	5.8

Foot bracket material: Carbon steel
Surface treatment: Nickel plated

Compact foot: CQ2WLC

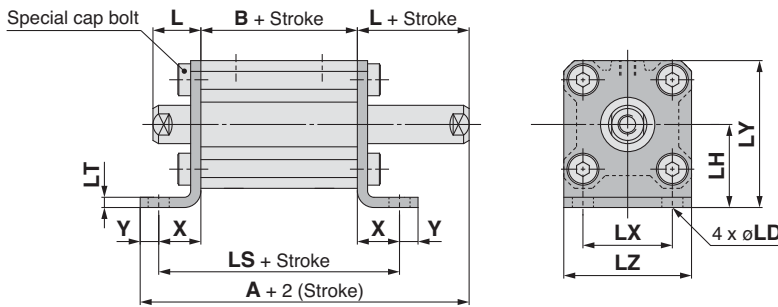

Note) The positions of left and right width across flats are not constant.

Rod end male thread

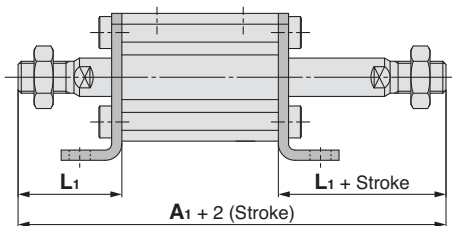

Rod End Male Thread (mm)

Bore size (mm)	A ₁	L ₁
12	73.2	24
16	77	25.5
20	83	28.5
25	94	32.5

Compact Foot

Bore size (mm)	Stroke range (mm)	A	B	L	LD	LH	LS	LT	LX	LY	LZ	X	Y
12	5 to 30	52.5	25.2	13.5	4.5	17	43.8	2	15.5	29.5	25	9.3	4.5
16	5 to 30	53.8	26	13.5	4.5	19	44.6	2	20	33.5	29	9.3	5
20	5 to 50	59.5	26	14.5	6.6	24	52.4	3.2	25.5	42	36	13.2	5.8
25	5 to 50	63	29	15	6.6	26	55.4	3.2	28	46	40	13.2	5.8

* For details about the rod end nut and accessory brackets, refer to page 23.

Compact foot bracket material: Carbon steel
Surface treatment: Zinc chromated

Standard

Large Bore Size

Long Stroke

Non-rotating Rod

Axial Piping

Anti-lateral Load

With End Lock

Water Resistant

With Auto Switch

Auto Switch

Made to Order

Compact Cylinder: Standard Double Acting, Double Rod *Series CQ2W*

Flange: CQ2WF

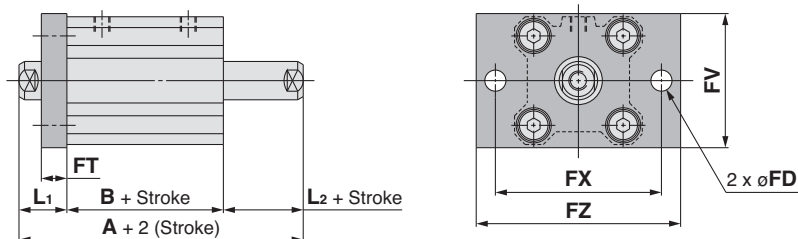

Note) The positions of left and right width across flats are not constant.

Rod end male thread

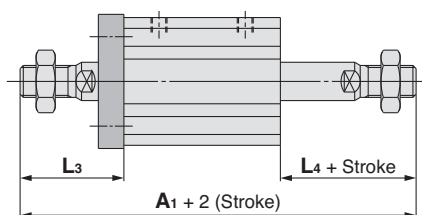

Rod End Male Thread (mm)

Bore size (mm)	A ₁	L ₃	L ₄
12	63.2	24	14
16	67	25.5	15.5
20	73	28.5	18.5
25	84	32.5	22.5

Flange (mm)

Bore size (mm)	Stroke range (mm)	A	B	FD	FT	FV	FX	FZ	L ₁	L ₂
12	5 to 30	42.2	25.2	4.5	5.5	25	45	55	13.5	3.5
16	5 to 30	43	26	4.5	5.5	30	45	55	13.5	3.5
20	5 to 50	45	26	6.6	8	39	48	60	14.5	4.5
25	5 to 50	49	29	6.6	8	42	52	64	15	5

* For details about the rod end nut and accessory brackets, refer to page 23.

Flange bracket material: Carbon steel
Surface treatment: Nickel plated

Dimensions

∅12 to ∅25/With Auto Switch

Both ends tapped: CDQ2WA

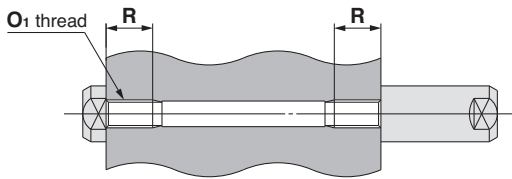

Both Ends Tapped (mm)

Bore size (mm)	O ₁	R
12	M4 x 0.7	7
16	M4 x 0.7	7
20	M6 x 1.0	10
25	M6 x 1.0	10

Standard (Through-hole): CDQ2WB

Note 1) The positions of left and right width across flats are not constant.

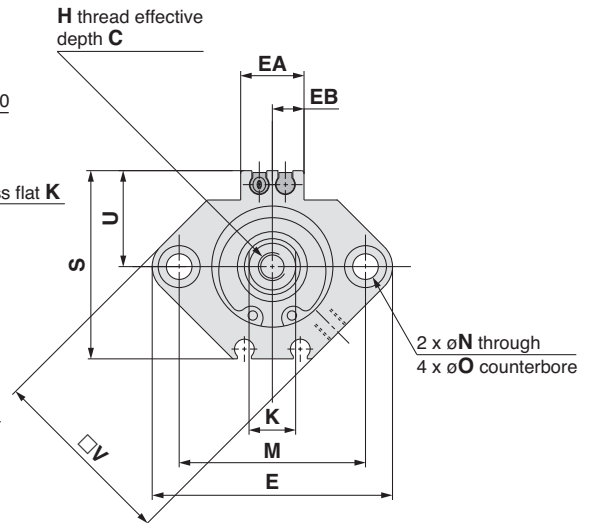
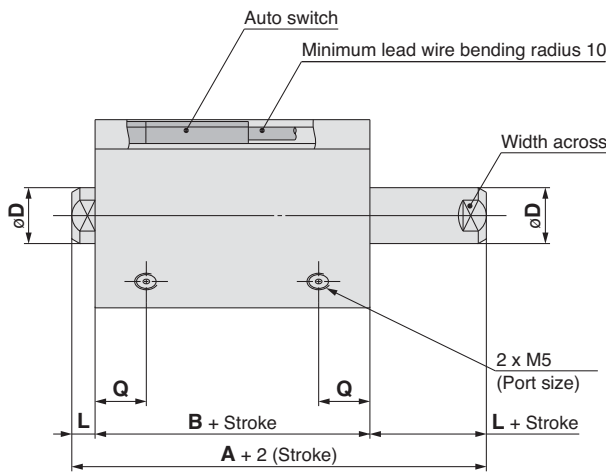

∅16 to ∅25

Rod end male thread

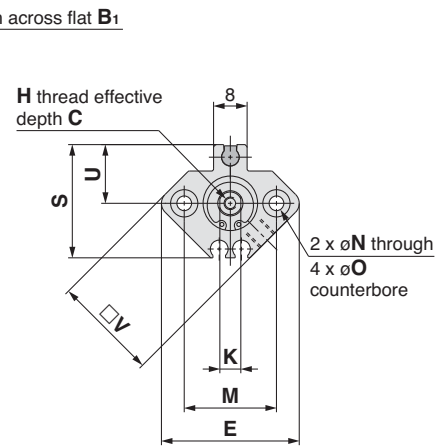
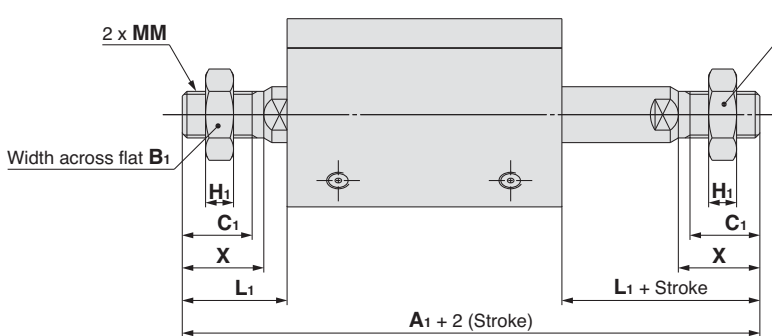

∅12

Rod End Male Thread (mm)

Bore size (mm)	A ₁	B ₁	C ₁	H ₁	L ₁	MM	X
12	60.4	8	9	4	14	M5 x 0.8	10.5
16	67	10	10	5	15.5	M6 x 1.0	12
20	75	13	12	5	18.5	M8 x 1.25	14
25	84	17	15	6	22.5	M10 x 1.25	17.5

Standard For auto switch proper mounting position and its mounting height, refer to pages 193 to 199.

Bore size (mm)	Stroke range (mm)	A	B	C	D	E	EA	EB	H	K	L	M	N	O	Q	S	U	V
12	5 to 30	39.4	32.4	6	6	33	—	—	M3 x 0.5	5	3.5	22	3.5	6.5 depth 3.5	10.5	27.5	14	25
16	5 to 30	43	36	8	8	37	13.2	6.6	M4 x 0.7	6	3.5	28	3.5	6.5 depth 3.5	10	29.5	15	29
20	5 to 50	47	38	7	10	47	13.6	6.8	M5 x 0.8	8	4.5	36	5.5	9 depth 7	8	35.5	18	36
25	5 to 50	49	39	12	12	52	13.6	6.8	M6 x 1.0	10	5	40	5.5	9 depth 7	9	40.5	21	40

Note 2) The external dimensions with rubber bumper are same as those of the standard, as shown above.

* For details about the rod end nut and accessory brackets, refer to page 23.

Standard

Large Bore Size

Long Stroke

Non-rotating Rod

Axial Piping

Anti-lateral Load

With End Lock

Water Resistant

With Auto Switch

Auto Switch

Made to Order

Compact Cylinder: Standard Double Acting, Double Rod *Series CQ2W*

Foot: CDQ2WL

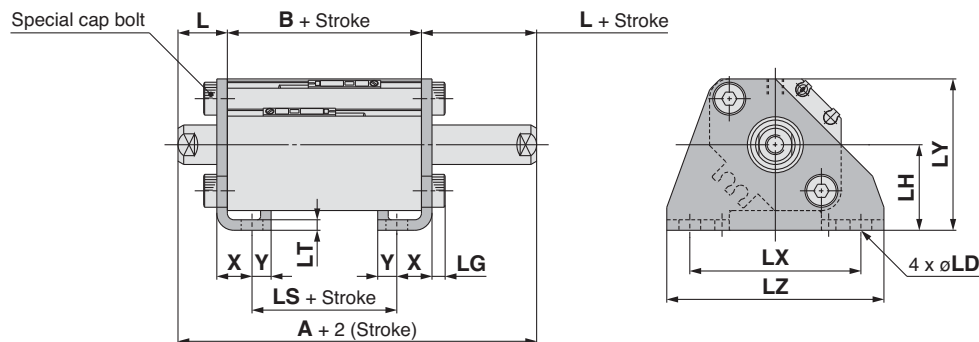

Note) The positions of left and right width across flats are not constant.

Rod end male thread

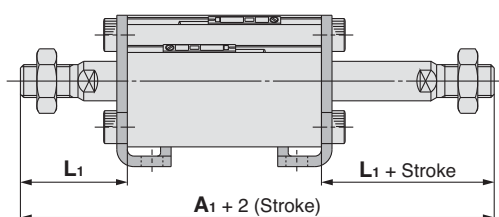

Rod End Male Thread (mm)

Bore size (mm)	A ₁	L ₁
12	80.4	24
16	87	25.5
20	95	28.5
25	104	32.5

Foot (mm)

Bore size (mm)	Stroke range (mm)	A	B	L	LD	LG	LH	LS	LT	LX	LY	LZ	X	Y
12	5 to 30	59.4	32.4	13.5	4.5	2.8	17	20.4	2	34	29.5	44	8	4.5
16	5 to 30	63	36	13.5	4.5	2.8	19	24	2	38	33.5	48	8	5
20	5 to 50	67	38	14.5	6.6	4	24	26	3.2	48	42	62	9.2	5.8
25	5 to 50	69	39	15	6.6	4	26	24	3.2	52	46	66	10.7	5.8

Foot bracket material: Carbon steel
Surface treatment: Nickel plated

Compact foot: CDQ2WLC

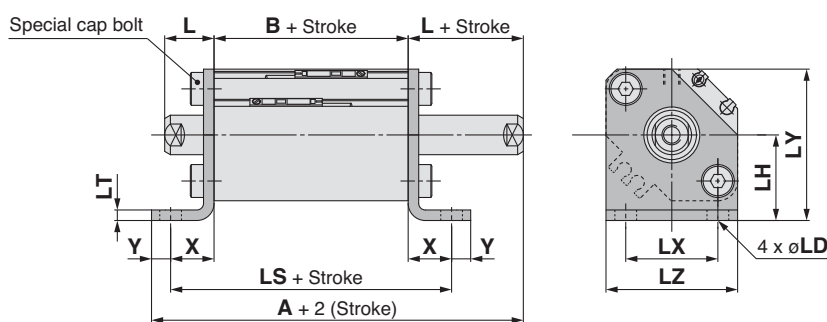

Note) The positions of left and right width across flats are not constant.

Rod end male thread

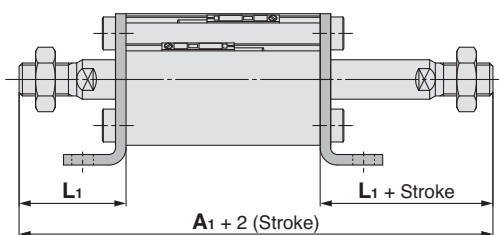

Rod End Male Thread (mm)

Bore size (mm)	A ₁	L ₁
12	80.4	24
16	87	25.5
20	95	28.5
25	104	32.5

Compact Foot (mm)

Bore size (mm)	Stroke range (mm)	A	B	L	LD	LH	LS	LT	LX	LY	LZ	X	Y
12	5 to 30	59.7	32.4	13.5	4.5	17	51	2	15.5	29.5	25	9.3	4.5
16	5 to 30	63.8	36	13.5	4.5	19	54.6	2	20	33.5	29	9.3	5
20	5 to 50	71.5	38	14.5	6.6	24	64.4	3.2	25.5	42	36	13.2	5.8
25	5 to 50	73	39	15	6.6	26	65.4	3.2	28	46	40	13.2	5.8

* For details about the rod end nut and accessory brackets, refer to page 23.

Compact foot bracket material: Carbon steel
Surface treatment: Zinc chromated

Flange: CDQ2WF

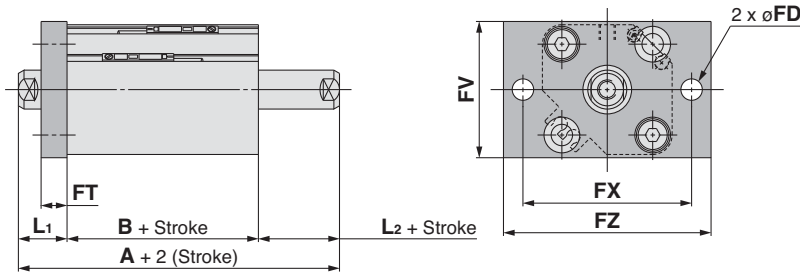

Note) The positions of left and right width across flats are not constant.

Rod end male thread

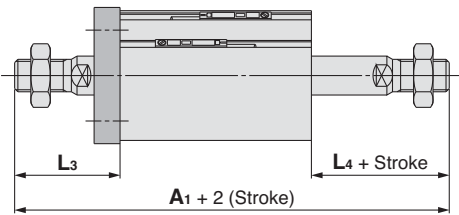

Rod End Male Thread (mm)

Bore size (mm)	A ₁	L ₃	L ₄
12	70.4	24	14
16	77	25.5	15.5
20	85	28.5	18.5
25	94	32.5	22.5

Flange

(mm)

Bore size (mm)	Stroke range (mm)	A	B	FD	FT	FV	FX	FZ	L ₁	L ₂
12	5 to 30	49.4	32.4	4.5	5.5	25	45	55	13.5	3.5
16	5 to 30	53	36	4.5	5.5	30	45	55	13.5	3.5
20	5 to 50	57	38	6.6	8	39	48	60	14.5	4.5
25	5 to 50	59	39	6.6	8	42	52	64	15	5

* For details about the rod end nut and accessory brackets, refer to page 23.

Flange bracket material: Carbon steel
Surface treatment: Nickel plated

Standard

Large Bore Size

Long Stroke

Non-rotating Rod

Axial Piping

Anti-lateral Load

With End Lock

Water Resistant

With Auto Switch

Auto Switch

Made to Order

Series CQ2W

Dimensions

Ø32 to Ø50/With Auto Switch

(In the case of without auto switches, the A, B and P dimensions will be only changed. Refer to the dimension table.)

Both ends tapped: CQ2WA/CDQ2WA

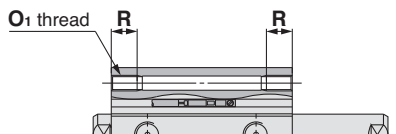

Both Ends Tapped

Bore size (mm)	O ₁	R
32	M6 x 1.0	10
40	M6 x 1.0	10
50	M8 x 1.25	14

Standard (Through-hole): CQ2WB/CDQ2WB

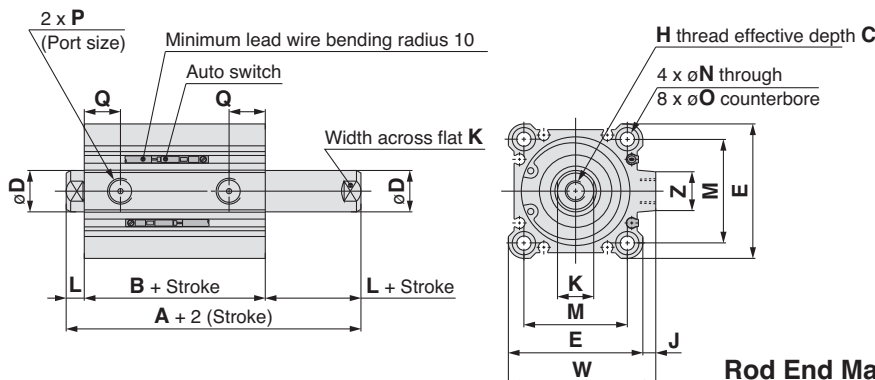

Note 1) The positions of left and right width across flats are not constant.

Rod end male thread

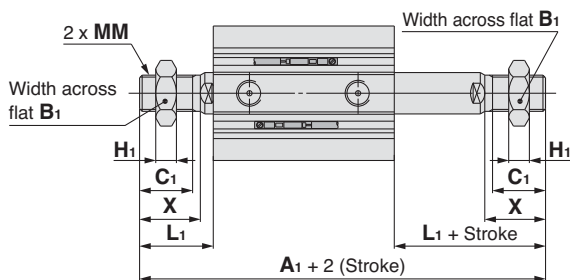

Rod End Male Thread

Bore size (mm)	Stroke range (mm)	Without auto switch		With auto switch	
		A ₁		A ₁	
32	5	87.5		97.5	
	10 to 50	87.5		97.5	
	75, 100	97.5		97.5	
40	5 to 50	97		107	
	75, 100	107		107	
50	10 to 50	107.5		117.5	
	75, 100	117.5		117.5	

Bore size (mm)	B ₁	C ₁	H ₁	L ₁	MM	X
32	22	20.5	8	28.5	M14 x 1.5	23.5
40	22	20.5	8	28.5	M14 x 1.5	23.5
50	27	26	11	33.5	M18 x 1.5	28.5

Built-in one-touch fittings: Ø32 to Ø50

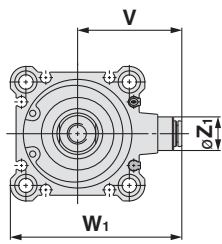
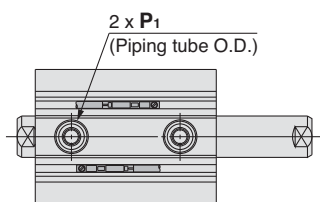

Built-in One-touch Fittings

Bore size (mm)	Without auto switch		With auto switch		Z ₁	P ₁
	V	W ₁	V	W ₁		
32	38	60.5	36.5	59	13	6
40	42	68	40.5	66.5	13	6
50	50	82	50	82	16	8

Standard For auto switch proper mounting position and its mounting height, refer to pages 193 to 199. (mm)

Bore size (mm)	Stroke range (mm)	Without auto switch			With auto switch		
		A	B	P	A	B	P
32	5	44.5	30.5	M5	54.5	40.5	1/8
	10 to 50	54.5	40.5	1/8			
	75, 100	54.5	40.5	1/8			
40	5 to 50	54	40	1/8	64	50	1/8
	75, 100	64	50	1/8			
50	10 to 50	56.5	40.5	1/4	66.5	50.5	1/4
	75, 100	66.5	50.5	1/4			

Bore size (mm)	C	D	E	H	J	K	L	M	N	O	Q	W	Z
32	13	16	45	M8 x 1.25	4.5	14	7	34	5.5	9 depth 7	10	49.5	14
40	13	16	52	M8 x 1.25	5	14	7	40	5.5	9 depth 7	12.5	57	15
50	15	20	64	M10 x 1.5	7	17	8	50	6.6	11 depth 8	14	71	19

Note 2) The external dimensions with rubber bumper are same as those of the standard, as shown above.

* For details about the rod end nut and accessory brackets, refer to page 23.

Compact Cylinder: Standard Double Acting, Double Rod *Series CQ2W*

Foot: CQ2WL/CDQ2WL

Note) The positions of left and right width across flats are not constant.

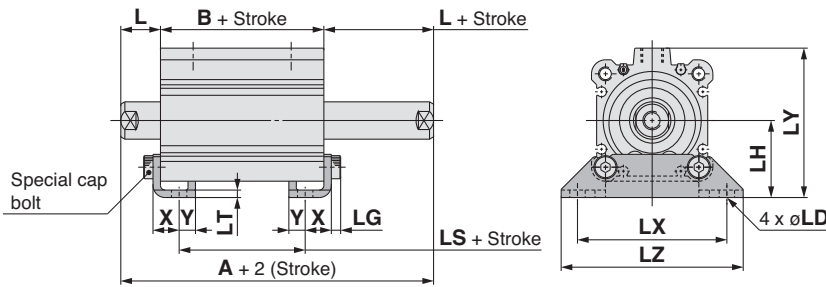

Rod end male thread

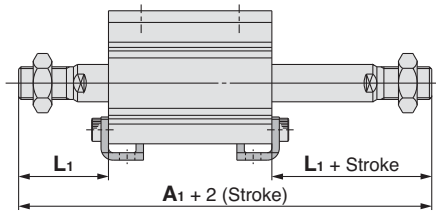

Rod End Male Thread (mm)

Bore size (mm)	Stroke range (mm)	Without auto switch	With auto switch	L ₁
		A ₁	A ₁	
32	5 to 50	107.5	117.5	38.5
	75, 100	117.5		
40	5 to 50	117	127	38.5
	75, 100	127		
50	10 to 50	127.5	137.5	43.5
	75, 100	137.5		

Foot

(mm)

Bore size (mm)	Stroke range (mm)	Without auto switch			With auto switch		
		A	B	LS	A	B	LS
32	5 to 50	64.5	30.5	14.5	74.5	40.5	24.5
	75, 100	74.5	40.5	24.5			
40	5 to 50	74	40	24	84	50	34
	75, 100	84	50	34			
50	10 to 50	76.5	40.5	17.5	86.5	50.5	27.5
	75, 100	86.5	50.5	27.5			

Foot bracket material: Carbon steel
Surface treatment: Nickel plated

Bore size (mm)	L	LD	LG	LH	LT	LX	LY	LZ	X	Y
32	17	6.6	4	30	3.2	57	57	71	11.2	5.8
40	17	6.6	4	33	3.2	64	64	78	11.2	7
50	18	9	5	39	3.2	79	78	95	14.7	8

Compact foot: CQ2WLC/CDQ2WLC

Note) The positions of left and right width across flats are not constant.

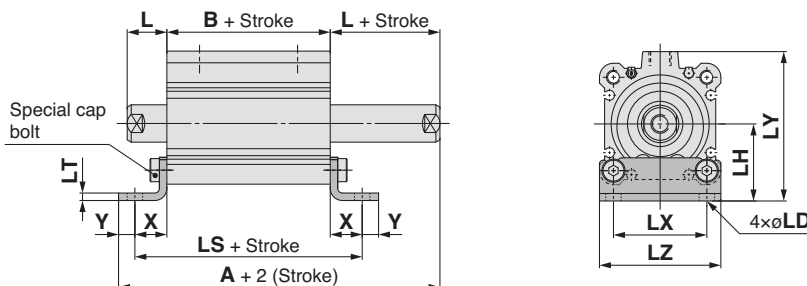

Rod end male thread

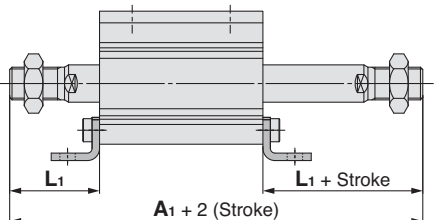

Rod End Male Thread (mm)

Bore size (mm)	Stroke range (mm)	Without auto switch	With auto switch	L ₁
		A ₁	A ₁	
32	5 to 50	107.5	117.5	38.5
	75, 100	117.5		
40	5 to 50	117	127	38.5
	75, 100	127		
50	10 to 50	127.5	137.5	43.5
	75, 100	137.5		

Compact Foot

(mm)

Bore size (mm)	Stroke range (mm)	Without auto switch			With auto switch			L	LD	LH	LT	LX	LY	LZ	X	Y
		A	B	LS	A	B	LS									
32	5 to 50	67	30.5	57.9	77	40.5	67.9	17	6.6	30	3.2	34	57	45	13.7	5.8
	75, 100	77	40.5	67.9												
40	5 to 50	77.7	40	67.4	87.7	50	77.4	17	6.6	33	3.2	40	64	52	13.7	7
	75, 100	87.7	50	77.4												
50	10 to 50	83.2	40.5	73.9	93.2	50.5	83.9	18	9	39	3.2	50	78	64	16.7	8
	75, 100	93.2	50.5	83.9												

Compact foot bracket material: Carbon steel
Surface treatment: Zinc chromated

Compact Cylinder: Standard Double Acting, Double Rod *Series CQ2W*

Flange: CQ2WF/CDQ2WF

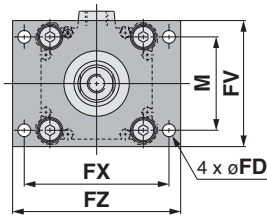
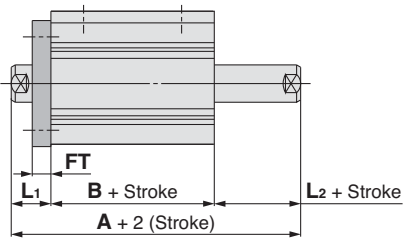

Note) The positions of left and right width across flats are not constant.

Rod end male thread

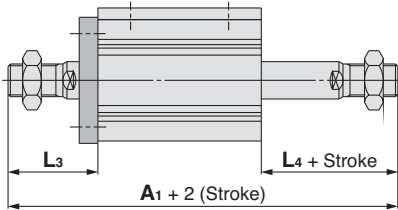

Rod End Male Thread (mm)

Bore size (mm)	Stroke range (mm)	Without auto switch	With auto switch	L ₃	L ₄
		A ₁	A ₁		
32	5 to 50	97.5	107.5	38.5	28.5
	75, 100	107.5			
40	5 to 50	107	117	38.5	28.5
	75, 100	117			
50	10 to 50	117.5	127.5	43.5	33.5
	75, 100	127.5			

Flange

(mm)

Bore size (mm)	Stroke range (mm)	Without auto switch		With auto switch		FD	FT	FV	FX	FZ	L ₁	L ₂	M
		A	B	A	B								
32	5 to 50	54.5	30.5	64.5	40.5	5.5	8	48	56	65	17	7	34
	75, 100	64.5	40.5										
40	5 to 50	64	40	74	50	5.5	8	54	62	72	17	7	40
	75, 100	74	50										
50	10 to 50	66.5	40.5	76.5	50.5	6.6	9	67	76	89	18	8	50
	75, 100	76.5	50.5										

Flange bracket material: Carbon steel
Surface treatment: Nickel plated

Series CQ2W

Dimensions

∅63 to ∅100/With Auto Switch

(In the case of without auto switches, the A and B dimensions will be only changed. Refer to the dimension table.)

Both ends tapped: CQ2WA/CDQ2WA

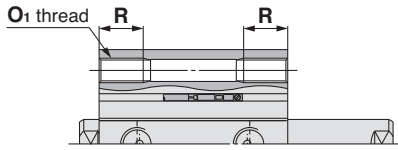

Both Ends Tapped

Bore size (mm)	O ₁	R
63	M10 x 1.5	18
80	M12 x 1.75	22
100	M12 x 1.75	22

Standard (Through-hole): CQ2WB/CDQ2WB

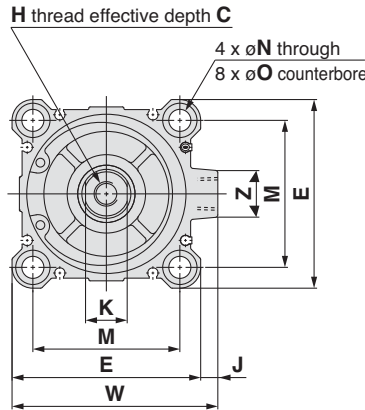
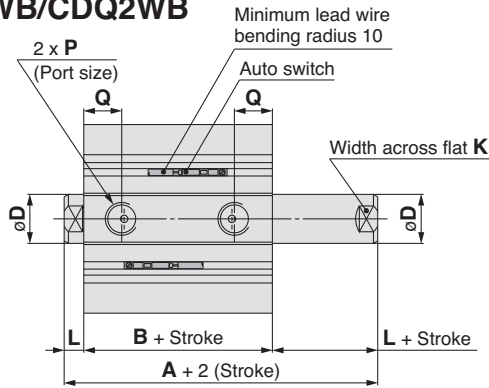

Note 1) The positions of left and right width across flats are not constant.

Rod end male thread

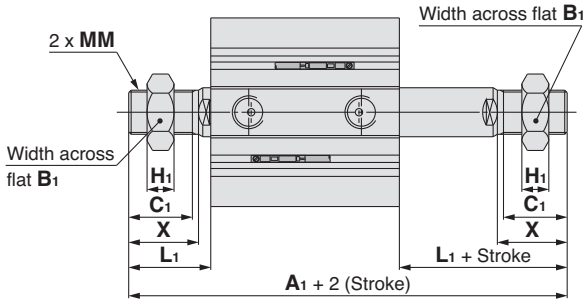

Rod End Male Thread

Bore size (mm)	Stroke range (mm)	(mm)	
		Without auto switch	With auto switch
63	10 to 50	A ₁	A ₁
	75, 100	109	119
80	10 to 50	138	148
	75, 100	148	148
100	10 to 50	147.5	157.5
	75, 100	157.5	157.5

(mm)

Bore size (mm)	B ₁	C ₁	H ₁	L ₁	MM	X
63	27	26	11	33.5	M18 x 1.5	28.5
80	32	32.5	13	43.5	M22 x 1.5	35.5
100	41	32.5	16	43.5	M26 x 1.5	35.5

Built-in one-touch fittings

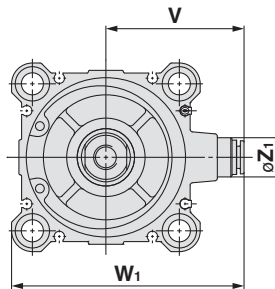
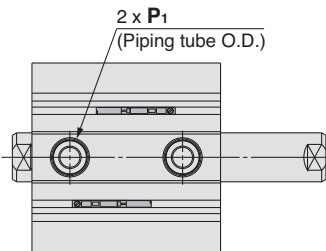

Built-in One-touch Fittings

Bore size (mm)	Z ₁	P ₁	V	W ₁
63	16	8	56.5	95

* The dimension of the ∅32-5 mm stroke with built-in one-touch fittings is the same as that of the 10 mm stroke cylinder tube.

For auto switch proper mounting position and its mounting height, refer to pages 193 to 199. (mm)

Bore size (mm)	Stroke range (mm)	Without auto switch		With auto switch	
		A	B	A	B
63	10 to 50	58	42	68	52
	75, 100	68	52		
80	10 to 50	71	51	81	61
	75, 100	81	61		
100	10 to 50	84.5	60.5	94.5	70.5
	75, 100	94.5	70.5		

(mm)

Bore size (mm)	C	D	E	H	J	K	L	M	N	O	P	Q	W	Z
63	15	20	77	M10 x 1.5	7	17	8	60	9	14 depth 10.5	1/4	15.5	84	19
80	21	25	98	M16 x 2.0	6	22	10	77	11	17.5 depth 13.5	3/8	18	104	25
100	27	30	117	M20 x 2.5	6.5	27	12	94	11	17.5 depth 13.5	3/8	22	123.5	25

Note 2) The external dimensions with rubber bumper are same as those of the standard, as shown above.

* For details about the rod end nut and accessory brackets, refer to page 23.

Standard
Large Bore Size
Long Stroke
Non-rotating Rod
Axial Piping
Anti-lateral Load
With End Lock
Water Resistant
With Auto Switch
Auto Switch
Made to Order

Compact Cylinder: Standard Double Acting, Double Rod *Series CQ2W*

Foot: CQ2WL/CDQ2WL

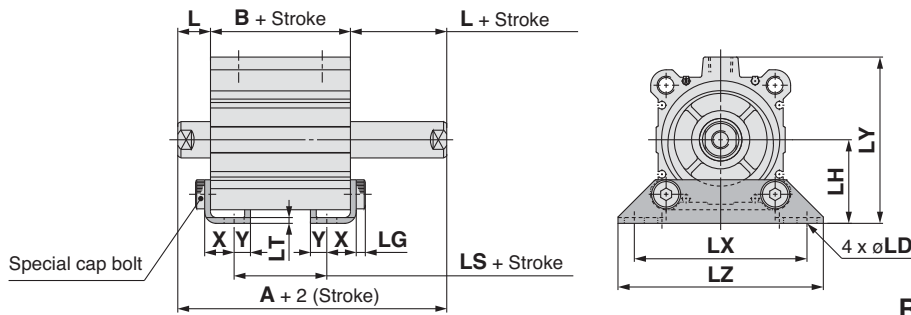

Note) The positions of left and right width across flats are not constant.

Rod end male thread

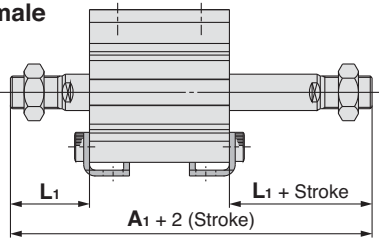

Rod End Male Thread (mm)

Bore size (mm)	Stroke range (mm)	Without auto switch	With auto switch	L ₁
		A ₁	A ₁	
63	10 to 50	129	139	43.5
	75, 100	139		
80	10 to 50	158	168	53.5
	75, 100	168		
100	10 to 50	167.5	177.5	53.5
	75, 100	177.5		

Foot (mm)

Bore size (mm)	Stroke range (mm)	Without auto switch			With auto switch		
		A	B	LS	A	B	LS
63	10 to 50	78	42	16	88	52	26
	75, 100	88	52	26			
80	10 to 50	91	51	21	101	61	31
	75, 100	101	61	31			
100	10 to 50	104.5	60.5	26.5	114.5	70.5	36.5
	75, 100	114.5	70.5	36.5			

Bore size (mm)	L	LD	LG	LH	LT	LX	LY	LZ	X	Y
63	18	11	5	46	3.2	95	91.5	113	16.2	9
80	20	13	7	59	4.5	118	114	140	19.5	11
100	22	13	7	71	6	137	136	162	23	12.5

Foot bracket material:
Carbon steel
Surface treatment:
Nickel plated

Compact foot: CQ2WLC/CDQ2WLC

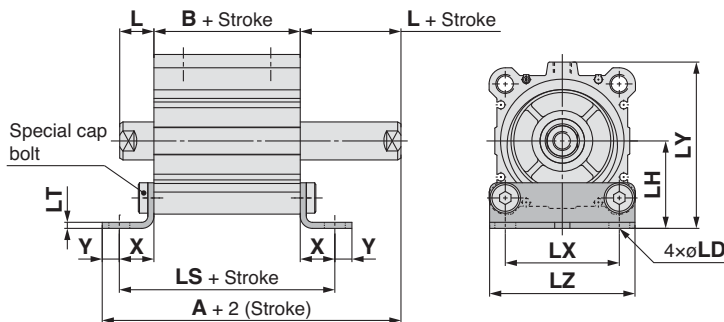

Note) The positions of left and right width across flats are not constant.

Rod end male thread

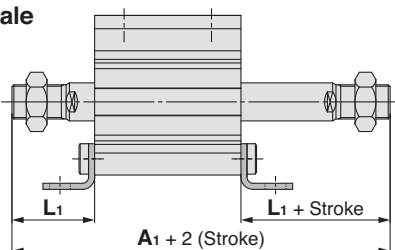

Rod End Male Thread (mm)

Bore size (mm)	Stroke range (mm)	Without auto switch	With auto switch	L ₁
		A ₁	A ₁	
63	10 to 50	129	139	43.5
	75, 100	139		
80	10 to 50	158	168	53.5
	75, 100	168		
100	10 to 50	167.5	177.5	53.5
	75, 100	177.5		

Compact Foot (mm)

Bore size (mm)	Stroke range (mm)	Without auto switch			With auto switch			L	LD	LH	LT	LX	LY	LZ	X	Y
		A	B	LS	A	B	LS									
63	10 to 50	87.2	42	78.4	97.2	52	88.4	18	11	46	3.2	60	91.5	77	18.2	9
	75, 100	97.2	52	88.4												
80	10 to 50	104.5	51	96	114.5	61	106	20	13	59	4.5	77	114	98	22.5	11
	75, 100	114.5	61	106												
100	10 to 50	119	60.5	108.5	129	70.5	118.5	22	13	71	6	94	136	117	24	12.5
	75, 100	129	70.5	118.5												

Flange: CQ2WF/CDQ2WF

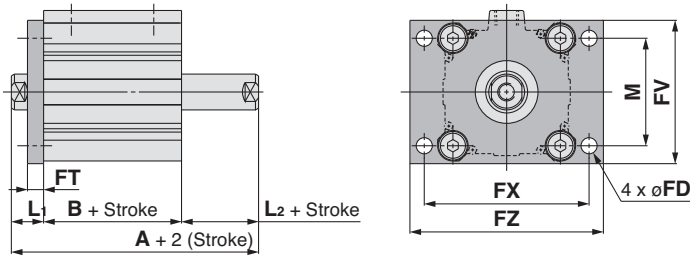

Note) The positions of left and right width across flats are not constant.

Rod end male thread

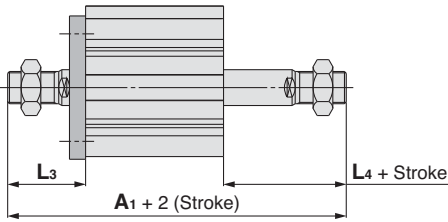

Rod End Male Thread

Bore size (mm)	Stroke range (mm)	(mm)			
		Without auto switch A ₁	With auto switch A ₁	L ₃	L ₄
63	10 to 50	119	129	43.5	33.5
	75, 100	129	129	43.5	33.5
80	10 to 50	148	158	53.5	43.5
	75, 100	158	158	53.5	43.5
100	10 to 50	157.5	167.5	53.5	43.5
	75, 100	167.5	167.5	53.5	43.5

Flange

Bore size (mm)	Stroke range (mm)	(mm)											
		Without auto switch		With auto switch		FD	FT	FV	FX	FZ	L ₁	L ₂	M
		A	B	A	B								
63	10 to 50	68	42	78	52	9	9	80	92	108	18	8	60
	75, 100	78	52	78	52	9	9	80	92	108	18	8	60
80	10 to 50	81	51	91	61	11	11	99	116	134	20	10	77
	75, 100	91	61	91	61	11	11	99	116	134	20	10	77
100	10 to 50	94.5	60.5	104.5	70.5	11	11	117	136	154	22	12	94
	75, 100	104.5	70.5	104.5	70.5	11	11	117	136	154	22	12	94

Flange bracket material: Carbon steel
Surface treatment: Nickel plated

Standard

Large Bore Size

Long Stroke

Non-rotating Rod

Axial Piping

Anti-lateral Load

With End Lock

Water Resistant

With Auto Switch

Auto Switch

Made to Order

Compact Cylinder: Standard Single Acting, Single Rod

Series CQ2

ø12, ø16, ø20, ø25, ø32, ø40, ø50

How to Order

Without auto switch
ø12 to ø25

CQ2 B 20 - 10 S

Without auto switch
ø32 to ø50

CQ2 B 32 - 10 S Z

With auto switch

CDQ2 B 32 - 10 S Z - L W - M9BW

With auto switch
(Built-in magnet)

Mounting

B	Through-hole (Standard)	F	Rod flange
A	Both ends tapped	G	Head flange
L	Foot	D	Double clevis
LC	Compact foot		

* Mounting brackets are shipped together, (but not assembled).

Bore size

12	12 mm
16	16 mm
20	20 mm
25	25 mm
32	32 mm
40	40 mm
50	50 mm

Port thread type

-	M thread	ø12 to ø25
	Rc	
TN	NPT	ø32 to ø50
TF	G	
F	Built-in one-touch fittings ^{Note)}	

Note) Bore sizes available with one-touch fittings are ø32 to ø50.

* For cylinders without auto switch, M threads are compatible only for ø32-5 mm stroke model.

Mounting bolt

-	None
L	Shipped together

* Mounting bolt is shipped together only when the mounting bracket is "B".

* For details about the mounting bolt sizes, refer to pages 49 and 52.

* Mounting bolt is shipped together.

Number of auto switches

-	2 pcs.
S	1 pc.
n	"n" pcs.

Auto switch

- Without auto switch
* Refer to the below table for applicable auto switches.

Made to Order

Refer to the next page for details.

Rod end bracket

(Refer to pages 23 and 24.)

-	None
D	Simple joint A type + Joint
E	Simple joint B type + Joint
V	Single knuckle joint
W	Double knuckle joint

* The single knuckle joint and double knuckle joint cannot be mounted for the rod end female thread.

* A knuckle joint pin is not provided with the single knuckle joint.

* The simple joint A and B types cannot be mounted for the rod end male thread.

* Rod end bracket is shipped together.

Auto switch mounting groove

Z	ø12 to ø25	2 surfaces
	ø32 to ø50	4 surfaces

Body option

-	Standard
F	With boss on head end
M	Rod end male thread

* Combination of body options ("FM") is available.

Action

S	Single acting, Spring return
T	Single acting, Spring extend

Cylinder stroke (mm)

Refer to the next page for standard strokes.

Built-in Magnet Cylinder Model

If a built-in magnet cylinder without an auto switch is required, there is no need to enter the symbol for the auto switch.

(Example) CDQ2L32-10SZ

Applicable Auto Switches/Refer to pages 1263 to 1371 in Best Pneumatics No. 2 for further information on auto switches.

Type	Special function	Electrical entry	Indicator light	Wiring (Output)	Load voltage		Auto switch model		Lead wire length (m)					Pre-wired connector	Applicable load			
					DC	AC	Perpendicular	In-line	0.5 (-)	1 (M)	3 (L)	5 (Z)	None (N)					
Solid state auto switch	—	Grommet	Yes	3-wire (NPN)	24 V	5 V, 12 V	—	M9NV	M9N	●	●	●	○	—	IC circuit	Relay, PLC		
				3-wire (PNP)				M9PV	M9P	●	●	●	○	—				
				2-wire				M9BV	M9B	●	●	●	○	—			—	
	3-wire (NPN)			M9NWV				M9NW	●	●	●	○	—	—				
	3-wire (PNP)			M9PWV				M9PW	●	●	●	○	—	—				
	2-wire			M9BWV				M9BW	●	●	●	○	—	—				
	Water resistant (2-colour indication)	Grommet	Yes	3-wire (NPN)	24 V	5 V, 12 V	—	M9NAV**	M9NA**	○	○	●	○	—	IC circuit	—		
				3-wire (PNP)				M9PAV**	M9PA**	○	○	●	○	—				
				2-wire				M9BAV**	M9BA**	○	○	●	○	—				
Reed auto switch	—	Grommet	Yes	3-wire (NPN equivalent)	24 V	5 V, 12 V	100 V or less	A96V	A96	●	—	●	—	IC circuit	—			
				2-wire				A93V	A93	●	—	●	—			—	—	Relay, PLC
								A90V	A90	●	—	●	—			—		

** Water resistant type auto switches can be mounted on the above models, but in such case SMC cannot guarantee water resistance. Consult with SMC regarding water resistant types with the above model numbers.

* Lead wire length symbols: 0.5 m — (Example) M9NW
1 m M (Example) M9NWM
3 m L (Example) M9NWL
5 m Z (Example) M9NWL

* Solid state auto switches marked with "○" are produced upon receipt of order.

* There are other applicable auto switches other than the listed above. For details, refer to page 199.

* For details about auto switches with pre-wired connector, refer to pages 1328 and 1329 in Best Pneumatics No. 2.

Series CQ2

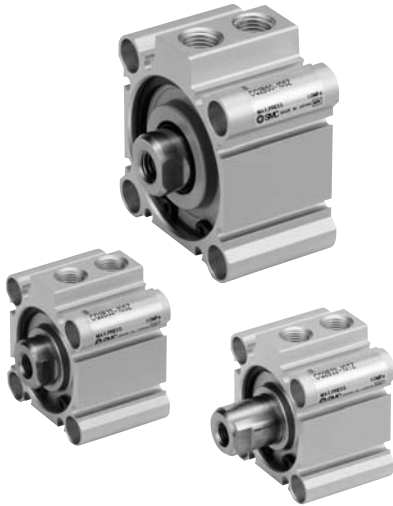

Symbol

Single acting,
Spring return

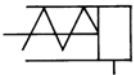

Single acting,
Spring extend



Made to Order

(For details, refer to pages 201 to 235.)

Symbol	Specifications
-XA□	Special rod end shape, spring return type only
-XB10	Intermediate stroke (Exclusive body type), Spring return type only
-XC2(A)	Rod end length, 10 mm increased (For foot and flange bracket)
-XC6	Piston rod/Retaining ring/Rod end nut material: Stainless steel
-XC26	With split pins for double clevis pin/ double knuckle joint pin and flat washers
-XC27	Double clevis pin/Double knuckle joint pin material: Stainless steel 304
-XC36	With boss on rod side
-XC85	Grease for food processing equipment
-X144	Special port location, with auto switch ø12 to ø25 only
-X202	Full length dimension is the same as Series CQ1, Except ø12, ø16, ø25.
-X203	L dimension from rod cover is the same as Series CQ1, ø20, ø32 only.
-X271	Fluororubber seals
-X1876	Cylinder tube: With concave boss on head side

Refer to pages 193 to 199 for the specifications of cylinders with autoswitches.

- Auto switch proper mounting position (detection at stroke end) and its mounting height
- Minimum stroke for auto switch mounting
- Operating range
- Auto switch mounting brackets/Part no.

Specifications

Bore size (mm)	12	16	20	25	32	40	50
Action	Single acting, Single rod						
Fluid	Air						
Proof pressure	1.5 MPa						
Maximum operating pressure	1.0 MPa						
Minimum operating pressure (MPa)	0.25	0.25	0.18	0.18	0.17	0.15	0.13
Ambient and fluid temperature	Without auto switch: -10 to 70°C (No freezing) With auto switch: -10 to 60°C (No freezing)						
Lubrication	Not required (Non-lube)						
Piston speed	50 to 500 mm/s						
Allowable kinetic energy (J)	0.022	0.038	0.055	0.09	0.15	0.26	0.46
Stroke length tolerance	+1.0 mm 0						

Standard Strokes

Bore size	Standard stroke (mm)
12, 16, 20, 25, 32, 40	5, 10
50	10, 20

Manufacture of Intermediate Strokes (Except single acting, spring return type)

Type	A spacer is installed in the standard stroke body.	
Part no.	Refer to "How to Order" for the standard model number. (P. 46)	
Description	Strokes in 1 mm intervals are available by installing a spacer in the standard stroke cylinder.	
Stroke range	Bore size	Stroke range
	12 to 40	1 to 9
	50	1 to 19
Example	Part no.: CQ2B20-3T CQ2B20-5T with 2 mm width spacer inside The B dimension is 24.5 mm.	

Type

		Bore size (mm)	12	16	20	25	32	40	50	
Pneumatic	Mounting	Through-hole (Standard)	●	●	●	●	●	●	●	
		Both ends tapped	●	●	●	●	●	●	●	
	Built-in magnet		●	●	●	●	●	●	●	
	Piping	Pipe thread	—	M5	M5	M5	M5	Note 1) M5 Rc1/8	Rc1/8	Rc1/4
			TN	—	—	—	—	NPT1/8	NPT1/8	NPT1/4
		TF	—	—	—	—	G1/8	G1/8	G1/4	
	Built-in one-touch fittings ^{Note 2)}		—	—	—	—	ø6/4	ø6/4	ø8/6	
	Rod end male thread		●	●	●	●	●	●	●	
	With boss on head end		●	●	●	●	●	●	●	

Note 1) ø32 without auto switch: M5 is used for 5 mm stroke/piping dimension.

Thus, do not enter a symbol for the port thread type.

Note 2) One-touch fittings cannot be replaced.

Retaining Ring Installation/Removal

⚠ Caution

- For installation and removal, use an appropriate pair of pliers (tool for installing a type C retaining ring).
- Even if a proper plier (tool for installing a type C retaining ring) is used, it is likely to inflict damage to a human body or peripheral equipment, as a retaining ring may be flown out of the tip of a plier (tool for installing a type C retaining ring). Be much careful with the popping of a retaining ring. Besides, be certain that a retaining ring is placed firmly into the groove of rod cover before supplying air at the time of installment.

Spring Force

Single Acting, Spring Return (N)

Bore size (mm)	Stroke (mm)	Spring reaction force (N)	
		Second	First
12	5	13	8.6
	10	13	3.9
16	5	15	10.3
	10	15	5.9
20	5	15	10
	10	15	5.9
25	5	20	16
	10	20	11
32	5	30	23
	10	30	16
40	5	30	13
	10	39	21
50	10	50	30
	20	54	24

Single Acting, Spring Extend (N)

Bore size (mm)	Stroke (mm)	Spring reaction force (N)	
		Second	First
12	5	11	2.9
	10	9.7	2.8
16	5	20	3.9
	10	20	3.9
20	5	27	5.3
	10	27	5.9
25	5	29	9.8
	10	29	9.8
32	5	29	20
	10	29	20
40	5	29	20
	10	29	20
50	10	83	24
	20	83	24

Single acting, Spring return

Spring state with first mounting load

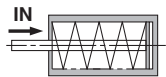

When spring is set in cylinder

Spring state with second mounting load

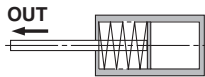

When spring is compressed with air

Single acting, Spring extend

Spring state with first mounting load

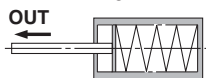

When spring is set in cylinder

Spring state with second mounting load

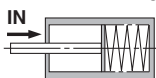

When spring is compressed with air

Mounting Brackets/Part No.

Bore size (mm)	Model	Foot ^{Note 1)}	Compact Foot ^{Note 1)}	Flange	Double clevis
12	Without switch CQ2□□-□□	CQ-L012	CQ-LC012	CQ-F012	CQ-D012
	With switch CQ2□□-□□Z	CQ-LZ12	CQ-LCZ12		
16	Without switch CQ2□□-□□	CQ-L016	CQ-LC016	CQ-F016	CQ-D016
	With switch CQ2□□-□□Z	CQ-LZ16	CQ-LCZ16		
20	Without switch CQ2□□-□□	CQ-L020	CQ-LC020	CQ-F020	CQ-D020
	With switch CQ2□□-□□Z	CQ-LZ20	CQ-LCZ20		
25	Without switch CQ2□□-□□	CQ-L025	CQ-LC025	CQ-F025	CQ-D025
	With switch CQ2□□-□□Z	CQ-LZ25	CQ-LCZ25		
32	CQ2□□-□□Z	CQ-L032	CQ-LC032	CQ-F032	CQ-D032
40	CQ2□□-□□Z	CQ-L040	CQ-LC040	CQ-F040	CQ-D040
50	CQ2□□-□□Z	CQ-L050	CQ-LC050	CQ-F050	CQ-D050

Note 1) When ordering a foot, and compact foot brackets, the required quantity will be different depending on the bore size.

- ø12 to ø25:
 - Without switch: Order 2 pieces per cylinder.
 - With switch: Order 1 piece per cylinder. (Part number for a set of 2 foot brackets)
- ø32 to ø100:
 - Order 2 pieces per cylinder.

Note 2) Parts belonging to each bracket are as follows.
Foot, Compact foot, Flange: Body mounting bolts
Double clevis: Clevis pin, Type C retaining rings for axis, Body mounting bolts

Theoretical Output

Action	Bore size (mm)	Operating pressure (MPa)		
		0.3	0.5	0.7
Spring return	12	21	44	66
	16	45	86	126
	20	79	142	205
	25	126	224	323
	32	211	372	533
Spring extend	12	14	31	48
	16	24	54	85
	20	44	91	138
	25	84	160	235
	32	152	273	393
	40	288	499	710
	50	412	742	1072

Weight

Weight (g)

Action	Bore size (mm)	Cylinder stroke (mm)			
		5	10	15	20
Spring return	12	29	35	—	—
	16	42	51	—	—
	20	63	76	—	—
	25	87	101	—	—
	32	125	145	—	—
	40	196	217	—	—
	50	—	357	—	426
Spring extend	12	29	35	—	—
	16	43	50	—	—
	20	67	78	—	—
	25	92	104	—	—
	32	135	151	—	—
	40	206	223	—	—
	50	—	374	—	429

Additional Weight (g)

Bore size (mm)		12	16	20	25	32	40	50
Both ends tapped		2	2	6	6	6	6	6
Rod end male thread	Male thread	1.5	3	6	12	26	27	53
	Nut	1	2	4	8	17	17	32
With boss on head side		0.7	1.3	2	3	5	7	13
Built-in one-touch fittings		—	—	—	—	6	6	10.5
Foot (Including mounting bolts)		55	67	164	186	142	154	243
Compact Foot (Including mounting bolts)		41	51	121	140	99	114	177
Rod flange (Including mounting bolts)		57	69	139	161	180	214	373
Head flange (Including mounting bolts)		54	65	133	152	165	198	348
Double clevis (Including pin, retaining rings, bolts)		32	39	88	123	151	196	393

Calculation: (Example) **CQ2D32-10SMZ**

- Basic weight: CQ2B32-10SZ 145 g
 - Additional weight: Both ends tapped 6 g
 - Rod end male thread 43 g
 - Double clevis 151 g
- 345 g

Series CQ2

Mounting Bolt for CQ2B/Without Auto Switch

Mounting method: Mounting bolt for through-hole mounting of the CQ2B is available as an option. Refer to the following for ordering procedures. Order the actual number of bolts that will be used.

Example) CQ-M3 x 25L 4 pcs.

Material: Chromium molybdenum steel
Surface treatment: Zinc chromated

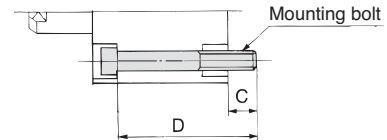
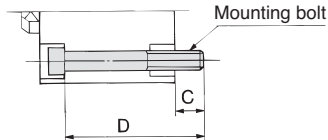

Spring Return

Cylinder model	C	D	Mounting bolt part no.
CQ2B12-5S	6.5	25	CQ-M3 x 25L
-10S		30	x 30L
CQ2B16-5S	5	25	CQ-M3 x 25L
-10S		30	x 30L
CQ2B20-5S	7.5	25	CQ-M5 x 25L
-10S		30	x 30L
CQ2B25-5S	9.5	30	CQ-M5 x 30L
-10S		35	x 35L
CQ2B32-5SZ	9	30	CQ-M5 x 30L
-10SZ		35	x 35L
CQ2B40-5SZ	7.5	35	CQ-M5 x 35L
-10SZ		40	x 40L
CQ2B50-10SZ	12.5	45	CQ-M6 x 45L
-20SZ		55	x 55L

Spring Extend

Cylinder model	C	D	Mounting bolt part no.
CQ2B12-5T	6.5	25	CQ-M3 x 25L
-10T		30	x 30L
CQ2B16-5T	5	25	CQ-M3 x 25L
-10T		30	x 30L
CQ2B20-5T	7.5	25	CQ-M5 x 25L
-10T		30	x 30L
CQ2B25-5T	9.5	30	CQ-M5 x 30L
-10T		35	x 35L
CQ2B32-5TZ	9	30	CQ-M5 x 30L
-10TZ		35	x 35L
CQ2B40-5TZ	7.5	35	CQ-M5 x 35L
-10TZ		40	x 40L
CQ2B50-10TZ	12.5	45	CQ-M6 x 45L
-20TZ		55	x 55L

Construction

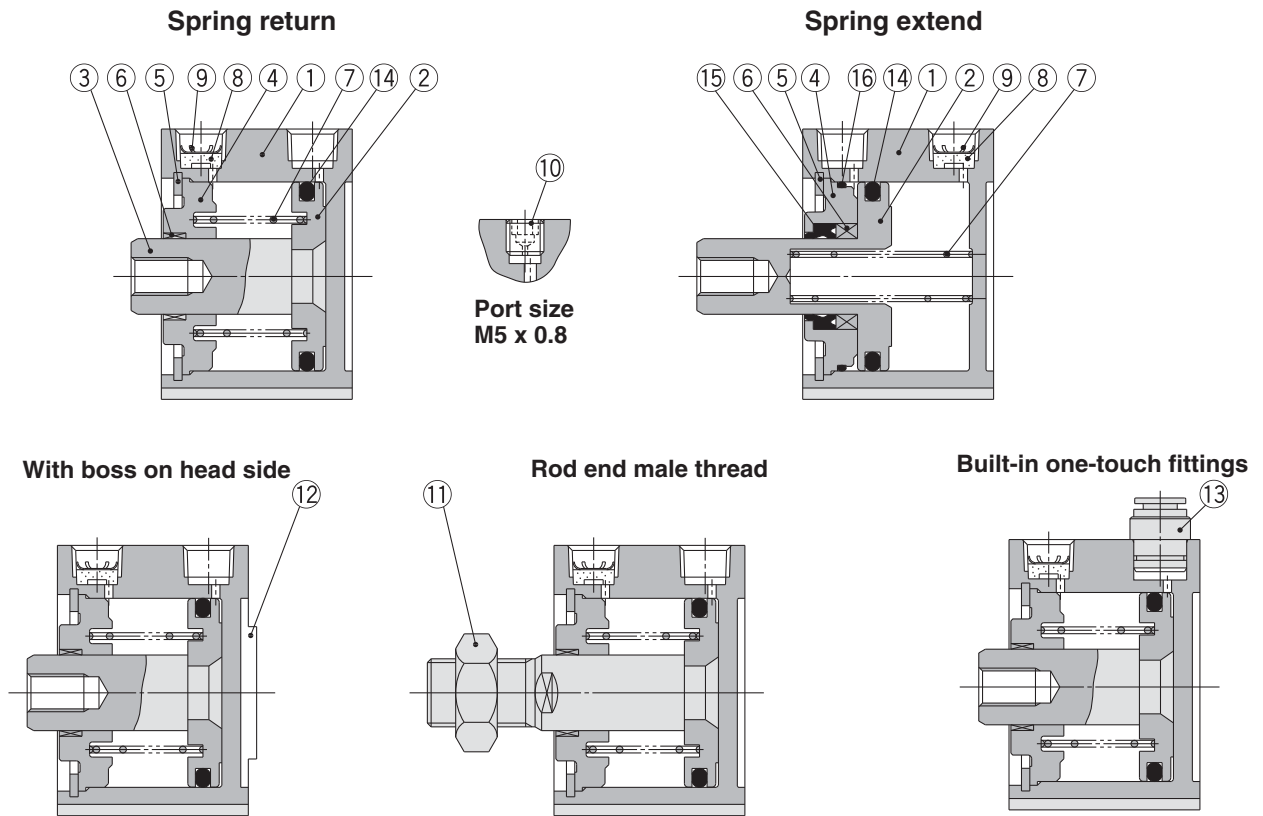

Component Parts

No.	Description	Material	Note
1	Cylinder tube	Aluminum alloy	Hard anodised
2*	Piston	Aluminum alloy	Chromated
3	Piston rod	Stainless steel	ø12 to ø25
		Carbon steel	ø32 to ø50, Hard chrome plated
4	Collar	Aluminum alloy	ø12 to ø40, Anodised
		Aluminum alloy casted	ø50, Chromated, Painted
5	Retaining ring	Carbon tool steel	Phosphate coated
6	Bushing	Bearing alloy	ø50
7	Return spring	Piano wire	Zinc chromated
8	Bronze element	Sintered metallic BC	Port size Rc1/8, 1/4
9	Retaining ring	Carbon tool steel	
10	Plug with fixed orifice	Alloy steel	Port size M5
11	Rod end nut	Carbon steel	Nickel plated
12	Centering location ring	Aluminum alloy	ø20 to ø50, Anodised
13	One-touch fitting	—	ø32 to ø50

* On spring extend (Type T), piston and piston rod are integrated (stainless steel). (Except ø12 and ø16 of built-in magnet type)

Replacement Parts

No.	Description	Material	Note
14	Piston seal	NBR	
15	Rod seal	NBR	
16	Gasket	NBR	

Replacement Parts/Seal Kit

Bore size (mm)	Single acting/Spring return	Single acting/Spring extend
12	CQ2B12-S-PS	CQ2B12-T-PS
16	CQ2B16-S-PS	CQ2B16-T-PS
20	CQ2B20-S-PS	CQ2B20-T-PS
25	CQ2B25-S-PS	CQ2B25-T-PS
32	CQ2B32-S-PS	CQ2B32-T-PS
40	CQ2B40-S-PS	CQ2B40-T-PS
50	CQ2B50-S-PS	CQ2B50-T-PS
Contents	Kits include item 14 from the above table.	Kits include items 14, 15, 16 from the above table.
How to Order	* Seal kit includes 14. Order the seal kit, based on each bore size.	* Seal kit includes 14, 15, 16. Order the seal kit, based on each bore size.

* Since the seal kit does not include a grease pack, order it separately. Grease pack part no.: GR-S-010 (10 g)

Copper and Fluorine-free Series (For CRT Manufacturing Process)

20 — C□Q2B — Bore size — Stroke $\frac{S}{T}$ (M)Z
 • Copper and fluorine-free series • ø12, ø16, ø20, ø25, ø32, ø40, ø50

For preventing the influence of copper ions or halogen ions during CRT manufacturing processes, copper and fluorine materials are not used in the component parts.

Specifications

Bore size (mm)	12	16	20	25	32	40	50
Action	Single acting, Single rod						
Proof pressure	1.5 MPa						
Max. operating pressure	1.0 MPa						
Rubber bumper	None						
Piping	Pipe thread						
Piston speed	50 to 500 mm/s						
Mounting	Through-hole						
Auto switch	Mountable						

Standard
 Large Bore Size
 Long Stroke
 Non-rotating Rod
 Axial Piping
 Anti-lateral Load
 With End Lock
 Water Resistant
 With Auto Switch
 Auto Switch
 Made to Order

Standard: Single Acting, Single Rod Series **CDQ2** With Auto Switch

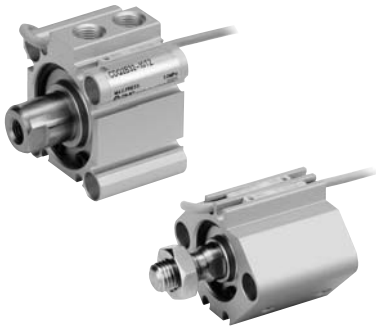

Refer to the below pages for further information on auto switches.

Auto switch proper mounting position and its mounting height	P.193 to 199
Minimum stroke for auto switch mounting	
Operating range	
Auto switch mounting brackets/Part no.	

Weight

Weight

Action	Bore size (mm)	Cylinder stroke (mm)			
		5	10	15	20
Spring return	12	44	49	—	—
	16	64	72	—	—
	20	97	109	—	—
	25	135	150	—	—
	32	182	202	—	—
	40	269	290	—	—
	50	—	456	—	521
Spring extend	12	49	65	—	—
	16	63	71	—	—
	20	110	119	—	—
	25	149	163	—	—
	32	192	208	—	—
	40	279	296	—	—
50	—	486	—	540	

Additional Weight

Bore size (mm)	12	16	20	25	32	40	50
Both ends tapped	1	1	3	3	6	6	6
Rod end male thread	Male thread	1.5	3	6	12	26	53
	Nut	1	2	4	8	17	32
With boss on head side	0.7	1.3	2	3	5	7	13
Built-in one-touch fittings	—	—	—	—	6	6	10.5
Foot (Including mounting bolts)	49	62	147	169	142	154	243
Compact foot (Including mounting bolts)	32	40	97	116	99	114	177
Rod flange (Including mounting bolts)	54	67	131	153	180	214	373
Head flange (Including mounting bolts)	52	63	124	144	165	198	348
Double clevis (Including pin, retaining rings, bolts)	29	35	78	114	151	196	393

Calculation: (Example) **CDQ2D32-10SMZ**

- Basic weight: CDQ2B32-10SZ 202 g
 - Additional weight: Both ends tapped 6 g
 - Rod end male thread 43 g
 - Double clevis 151 g
- 402 g

Add each weight of auto switches when auto switches are mounted.

Construction

Spring return

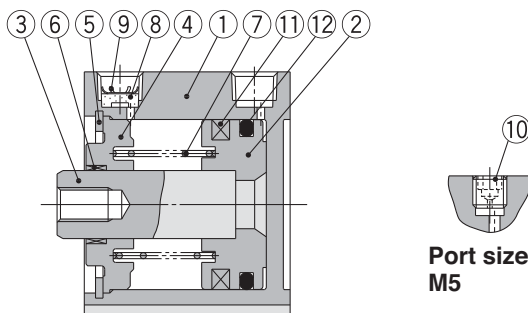

Spring extend

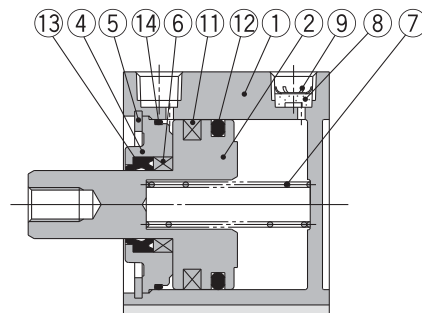

Component Parts

No.	Description	Material	Note
1	Cylinder tube	Aluminum alloy	Hard anodised
2	Piston	Aluminum alloy	Chromated
3	Piston rod	Stainless steel	ø12 to ø25
		Carbon steel	ø32 to ø50, Hard chrome plated
4	Collar	Aluminum alloy	ø12 to ø40, Anodised
		Aluminum alloy casted	ø50, Chromated, Painted
5	Retaining ring	Carbon tool steel	Phosphate coated
6	Bushing	Bearing alloy	ø50
7	Return spring	Piano wire	Zinc chromated
8	Bronze element	Sintered metallic BC	Port size Rc1/8, 1/4
9	Retaining ring	Carbon tool steel	
10	Plug with fixed orifice	Alloy steel	Port size M5
11	Magnet	—	

No.	Description	Material	Note
12	Piston seal	NBR	
13	Rod seal	NBR	
14	Gasket	NBR	



Replacement Parts/Seal Kit

Since the same as those of the standard, single acting, single rod, refer to page 50.

Mounting Bolt for CDQ2B/With Auto Switch

Mounting method: Mounting bolt for through-hole mounting of the CDQ2B is available as an option. Refer to the following for ordering procedures. Order the actual number of bolts that will be used.

Example) CQ-M3 x 35L 2 pcs.

Material: Chromium molybdenum steel
Surface treatment: Zinc chromated

Spring return

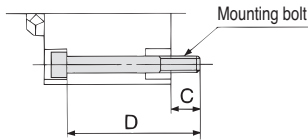

Spring extend

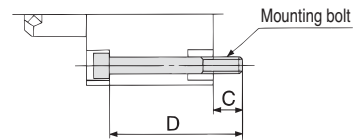

Spring Return

Cylinder model	C	D	Mounting bolt part no.
CDQ2B12-5SZ	5.5	35	CQ-M3 x 35L
-10SZ		40	x 40L
CDQ2B16-5SZ	8	40	CQ-M3 x 40L
-10SZ		45	x 45L
CDQ2B20-5SZ	10.5	40	CQ-M5 x 40L
-10SZ		45	x 45L
CDQ2B25-5SZ	9.5	40	CQ-M5 x 40L
-10SZ		45	x 45L
CDQ2B32-5SZ	9	40	CQ-M5 x 40L
-10SZ		45	x 45L
CDQ2B40-5SZ	7.5	45	CQ-M5 x 45L
-10SZ		50	x 50L
CDQ2B50-10SZ	12.5	55	CQ-M6 x 55L
-20SZ		65	x 65L

Spring Extend

Cylinder model	C	D	Mounting bolt part no.
CDQ2B12-5TZ	6.1	40	CQ-M3 x 40L
-10TZ		45	x 45L
CDQ2B16-5TZ	8	40	CQ-M3 x 40L
-10TZ		45	x 45L
CDQ2B20-5TZ	10.5	40	CQ-M5 x 40L
-10TZ		45	x 45L
CDQ2B25-5TZ	9.5	40	CQ-M5 x 40L
-10TZ		45	x 45L
CDQ2B32-5TZ	9	40	CQ-M5 x 40L
-10TZ		45	x 45L
CDQ2B40-5TZ	7.5	45	CQ-M5 x 45L
-10TZ		50	x 50L
CDQ2B50-10TZ	12.5	55	CQ-M6 x 55L
-20TZ		65	x 65L

Standard

Large Bore Size

Long Stroke

Non-rotating Rod

Axial Piping

Anti-lateral Load

With End Lock

Water Resistant

With Auto Switch

Auto Switch

Made to Order

Series CQ2

Dimensions

Ø12 to Ø25/Spring Return Without Auto Switch

Both ends tapped: CQ2A

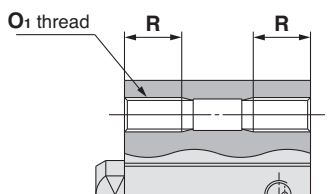

Both Ends Tapped (mm)

Bore size (mm)	O1	R
12	M4 x 0.7	7
16	M4 x 0.7	7
20	M6 x 1.0	10
25	M6 x 1.0	10

Standard (Through-hole): CQ2B

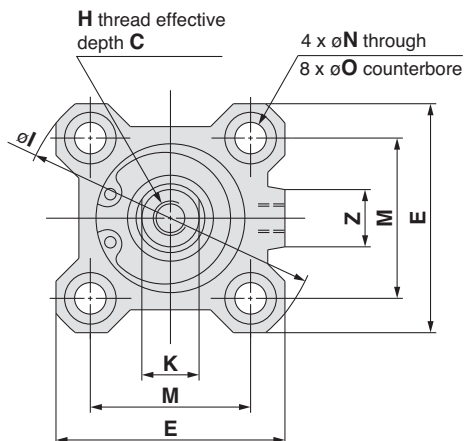
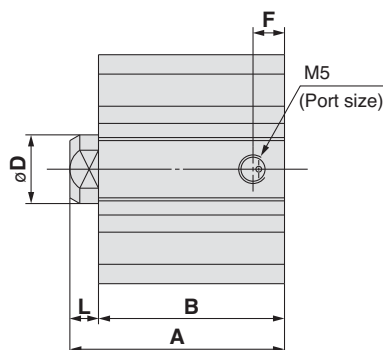

With boss on head side

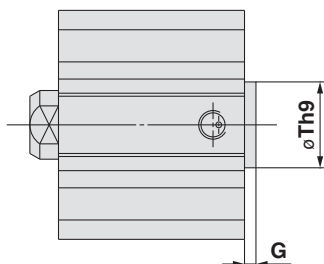

With Boss on Head Side (mm)

Bore size (mm)	G	Th9
12	1.5	15 ⁰ _{-0.043}
16	1.5	20 ⁰ _{-0.052}
20	2	13.5 ⁰ _{-0.043}
25	2	15 ⁰ _{-0.043}

Note) With boss on rod cover side:
Option (Suffix "-XC36" to the end of model number.)

Rod end male thread

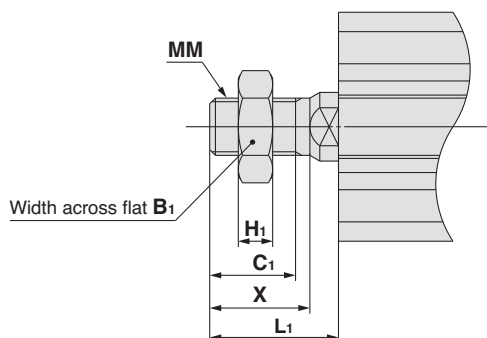

Rod End Male Thread (mm)

Bore size (mm)	B ₁	C ₁	H ₁	L ₁	MM	X
12	8	9	4	14	M5 x 0.8	10.5
16	10	10	5	15.5	M6 x 1.0	12
20	13	12	5	18.5	M8 x 1.25	14
25	17	15	6	22.5	M10 x 1.25	17.5

Standard

Bore size (mm)	Stroke (mm)	A	B	C	D	E	F	H	I	K	L	M	N	O	Z
12	5	25.5	22	6	6	25	5	M3 x 0.5	32	5	3.5	15.5	3.5	6.5 depth 3.5	—
	10	30.5	27												
16	5	27	23.5	8	8	29	5.5	M4 x 0.7	38	6	3.5	20	3.5	6.5 depth 3.5	10
	10	32	28.5												
20	5	29	24.5	7	10	36	5.5	M5 x 0.8	47	8	4.5	25.5	5.5	9 depth 7	10
	10	34	29.5												
25	5	32.5	27.5	12	12	40	5.5	M6 x 1.0	52	10	5	28	5.5	9 depth 7	10
	10	37.5	32.5												

* For details about the rod end nut and accessory brackets, refer to page 23.

Foot: CQ2L

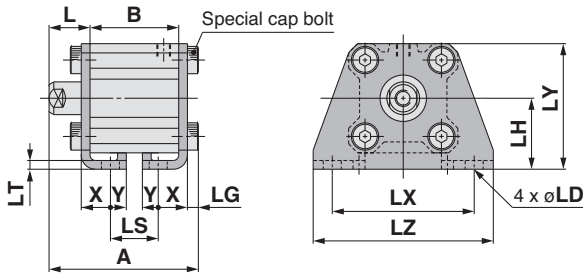

Rod end male thread

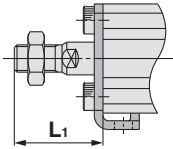

Foot

Bore size (mm)	A		B		L	L ₁	LD	LG	LH	LS	
	5st	10st	5st	10st						5st	10st
12	40.3	45.3	22	27	13.5	24	4.5	2.8	17	10	15
16	41.8	46.8	23.5	28.5	13.5	25.5	4.5	2.8	19	11.5	16.5
20	46.2	51.2	24.5	29.5	14.5	28.5	6.6	4	24	12.5	17.5
25	49.7	54.7	27.5	32.5	15	32.5	6.6	4	26	12.5	17.5

Bore size (mm)	LT	LX	LY	LZ	X	Y
12	2	34	29.5	44	8	4.5
16	2	38	33.5	48	8	5
20	3.2	48	42	62	9.2	5.8
25	3.2	52	46	66	10.7	5.8

Foot bracket material: Carbon steel
Surface treatment: Nickel plated

Compact foot: CQ2LC

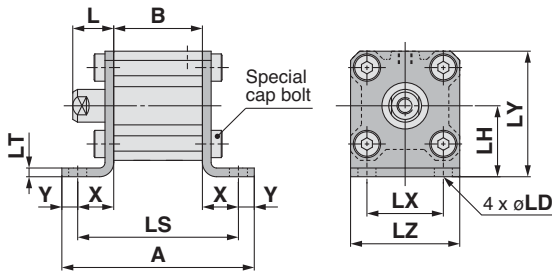

Rod end male thread

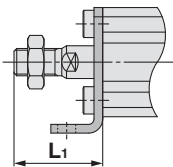

Compact Foot

Bore size (mm)	A		B		L	L ₁	LD	LH	LS		LT
	5st	10st	5st	10st					5st	10st	
12	49.6	54.6	22	27	13.5	24	4.5	17	40.6	45.6	2
16	52.1	57.1	23.5	28.5	13.5	25.5	4.5	19	42.1	47.1	2
20	62.5	67.5	24.5	29.5	14.5	28.5	6.6	24	50.9	55.9	3.2
25	65.5	70.5	27.5	32.5	15	32.5	6.6	26	53.9	58.9	3.2

Bore size (mm)	LX	LY	LZ	X	Y
12	15.5	29.5	25	9.3	4.5
16	20	33.5	29	9.3	5
20	25.5	42	36	13.2	5.8
25	28	46	40	13.2	5.8

Compact foot bracket material: Carbon steel
Surface treatment: Zinc chromated

Rod flange: CQ2F

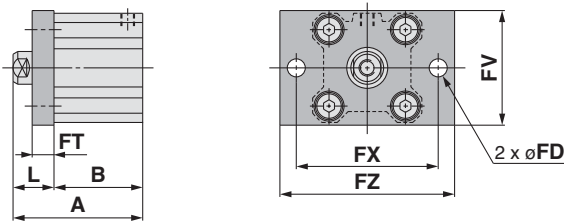

Rod end male thread

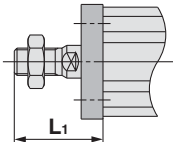

Rod Flange

Bore size (mm)	A		B		FD	FT	FV	FX	FZ	L	L ₁
	5st	10st	5st	10st							
12	35.5	40.5	22	27	4.5	5.5	25	45	55	13.5	24
16	37	42	23.5	28.5	4.5	5.5	30	45	55	13.5	25.5
20	39	44	24.5	29.5	6.6	8	39	48	60	14.5	28.5
25	42.5	47.5	27.5	32.5	6.6	8	42	52	64	15	32.5

Flange bracket material: Carbon steel
Surface treatment: Nickel plated

Head flange: CQ2G

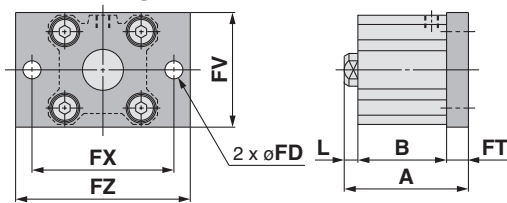

Rod end male thread

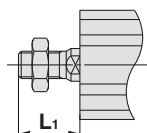

Head Flange

Bore size (mm)	A		L	L ₁
	5st	10st		
12	31	36	3.5	14
16	32.5	37.5	3.5	15.5
20	37	42	4.5	18.5
25	40.5	45.5	5	22.5

Flange bracket material: Carbon steel
Surface treatment: Nickel plated

(* The dimensions except A, L and L₁ are the same as those of the rod flange.)

Compact Cylinder: Standard
Single Acting, Single Rod **Series CQ2**

Double clevis: CQ2D

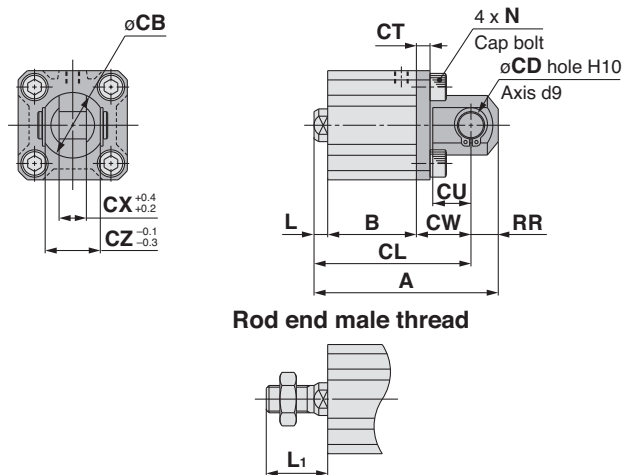

Double Clevis

Bore size (mm)	A		B		CB	CD	CL		CT	CU	CW
	5st	10st	5st	10st			5st	10st			
12	45.5	50.5	22	27	12	5	39.5	44.5	4	7	14
16	48	53	23.5	28.5	14	5	42	47	4	10	15
20	56	61	24.5	29.5	20	8	47	52	5	12	18
25	62.5	67.5	27.5	32.5	24	10	52.5	57.5	5	14	20

Bore size (mm)	CX	CZ	L	L ₁	N	RR
12	5	10	3.5	14	M4 x 0.7	6
16	6.5	12	3.5	15.5	M4 x 0.7	6
20	8	16	4.5	18.5	M6 x 1.0	9
25	10	20	5	22.5	M6 x 1.0	10

Double clevis bracket material: Carbon steel
Surface treatment: Nickel plated

- * For details about the rod end nut and accessory brackets, refer to page 23.
- * Double clevis pin and retaining rings are included.

Series CQ2

Dimensions

ø12 to ø25/Spring Return With Auto Switch

Both ends tapped: CDQ2A

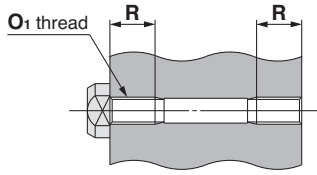

Both Ends Tapped (mm)

Bore size (mm)	O ₁	R
12	M4 x 0.7	7
16	M4 x 0.7	7
20	M6 x 1.0	10
25	M6 x 1.0	10

Standard (Through-hole): CDQ2B

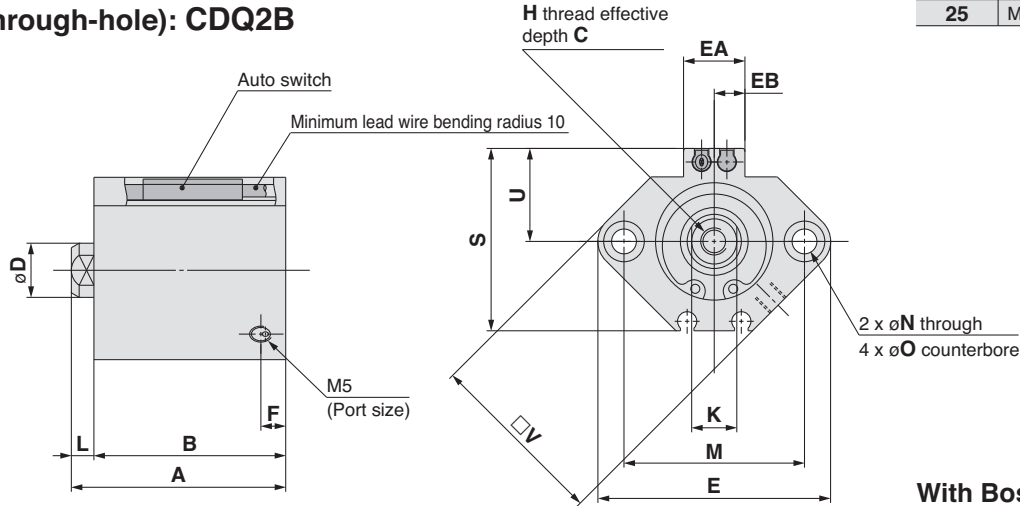

With boss on head side

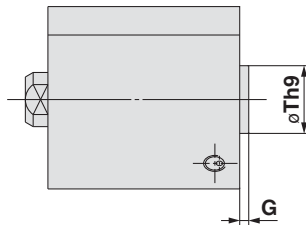

With Boss on Head Side (mm)

Bore size (mm)	G	Th9
12	1.5	15 ⁰ _{-0.043}
16	1.5	20 ⁰ _{-0.052}
20	2	13 ⁰ _{-0.043}
25	2	15 ⁰ _{-0.043}

Note) With boss on rod cover side: Option (Suffix "XC36" to the end of model number.)

Rod end male thread

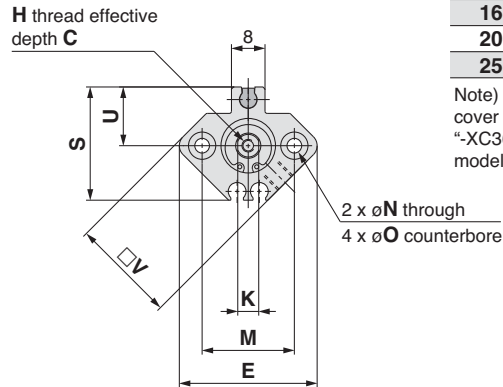
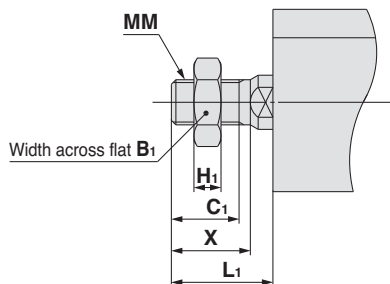

Rod End Male Thread (mm)

Bore size (mm)	B ₁	C ₁	H ₁	L ₁	MM	X
12	8	9	4	14	M5 x 0.8	10.5
16	10	10	5	15.5	M6 x 1.0	12
20	13	12	5	18.5	M8 x 1.25	14
25	17	15	6	22.5	M10 x 1.25	17.5

Standard For auto switch proper mounting position and its mounting height, refer to pages 193 to 199.

Bore size (mm)	Stroke (mm)	A	B	C	D	E	EA	EB	F	H	K	L	M	N	O	S	U	V
12	5	36.5	33	6	6	33	—	—	6.5	M3 x 0.5	5	3.5	22	3.5	6.5 depth 3.5	27.5	14	25
	10	41.5	38	6	6	33	—	—	6.5	M3 x 0.5	5	3.5	22	3.5	6.5 depth 3.5	27.5	14	25
16	5	39	35.5	8	8	37	13.2	6.6	5.5	M4 x 0.7	6	3.5	28	3.5	6.5 depth 3.5	29.5	15	29
	10	44	40.5	8	8	37	13.2	6.6	5.5	M4 x 0.7	6	3.5	28	3.5	6.5 depth 3.5	29.5	15	29
20	5	41	36.5	7	10	47	13.6	6.8	5.5	M5 x 0.8	8	4.5	36	5.5	9 depth 7	35.5	18	36
	10	46	41.5	7	10	47	13.6	6.8	5.5	M5 x 0.8	8	4.5	36	5.5	9 depth 7	35.5	18	36
25	5	42.5	37.5	12	12	52	13.6	6.8	5.5	M6 x 1.0	10	5	40	5.5	9 depth 7	40.5	21	40
	10	47.5	42.5	12	12	52	13.6	6.8	5.5	M6 x 1.0	10	5	40	5.5	9 depth 7	40.5	21	40

* For details about the rod end nut and accessory brackets, refer to page 23.

Standard

Large Bore Size

Long Stroke

Non-rotating Rod

Axial Piping

Anti-lateral Load

With End Lock

Water Resistant

With Auto Switch

Auto Switch

Made to Order

Compact Cylinder: Standard Single Acting, Single Rod **Series CQ2**

Foot: CDQ2L

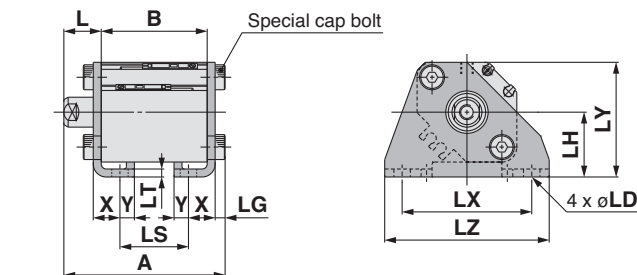

Rod end male thread

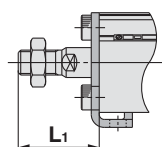

Foot

Bore size (mm)	A		B		L	L ₁	LD	LG	LH	LS	
	5st	10st	5st	10st						5st	10st
	12	51.3	56.3	33						38	13.5
16	53.8	58.8	35.5	40.5	13.5	25.5	4.5	2.8	19	23.5	28.5
20	58.2	63.2	36.5	41.5	14.5	28.5	6.6	4	24	24.5	29.5
25	59.7	64.7	37.5	42.5	15	32.5	6.6	4	26	22.5	27.5

Bore size (mm)	LT	LX	LY	LZ	X	Y
12	2	34	29.5	44	8	4.5
16	2	38	33.5	48	8	5
20	3.2	48	42	62	9.2	5.8
25	3.2	52	46	66	10.7	5.8

Foot bracket material: Carbon steel
Surface treatment: Nickel plated

Compact foot: CDQ2LC

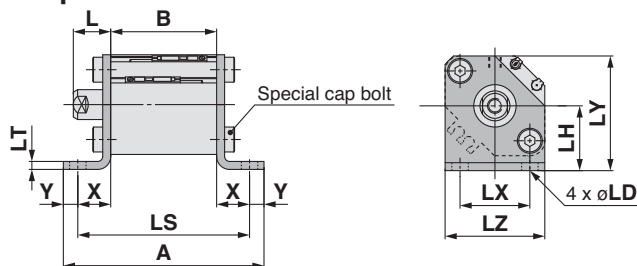

Rod end male thread

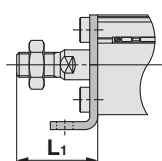

Compact Foot

Bore size (mm)	A		B		L	L ₁	LD	LH	LS		LT
	5st	10st	5st	10st					5st	10st	
	12	60.6	65.6	33					38	13.5	
16	64.1	69.1	35.5	40.5	13.5	25.5	4.5	19	54.1	59.1	2
20	74.5	79.5	36.5	41.5	14.5	28.5	6.6	24	62.9	67.9	3.2
25	75.5	80.5	37.5	42.5	15	32.5	6.6	26	63.9	68.9	3.2

Bore size (mm)	LX	LY	LZ	X	Y
12	15.5	29.5	25	9.3	4.5
16	20	33.5	29	9.3	5
20	25.5	42	36	13.2	5.8
25	28	46	40	13.2	5.8

Compact foot bracket material: Carbon steel
Surface treatment: Zinc chromated

Rod flange: CDQ2F

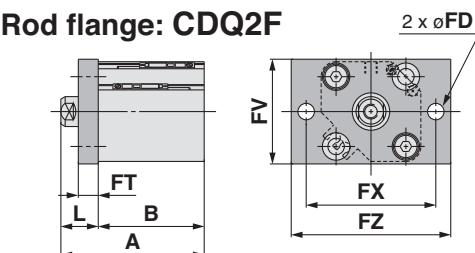

Rod end male thread

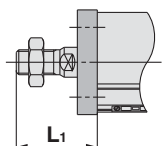

Rod Flange

Bore size (mm)	A		B		FD	FT	FV	FX	FZ	L	L ₁
	5st	10st	5st	10st							
	12	46.5	51.5	33							
16	49	54	35.5	40.5	4.5	5.5	30	45	55	13.5	25.5
20	51	56	36.5	41.5	6.6	8	39	48	60	14.5	28.5
25	52.5	57.5	37.5	42.5	6.6	8	42	52	64	15	32.5

Flange bracket material: Carbon steel
Surface treatment: Nickel plated

Head flange: CDQ2G

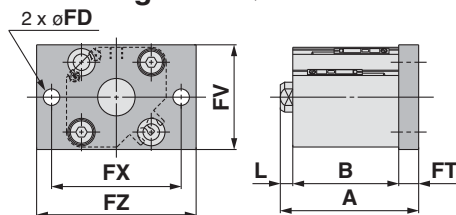

Rod end male thread

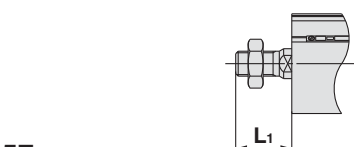

Head Flange

Bore size (mm)	A		L	L ₁
	5st	10st		
	12	46.4		
16	44.5	49.5	3.5	15.5
20	49	54	4.5	18.5
25	50.5	55.5	5	22.5

(* The dimensions except A, L and L₁ are the same as those of the rod flange.)

Flange bracket material: Carbon steel
Surface treatment: Nickel plated

Double clevis: CDQ2D

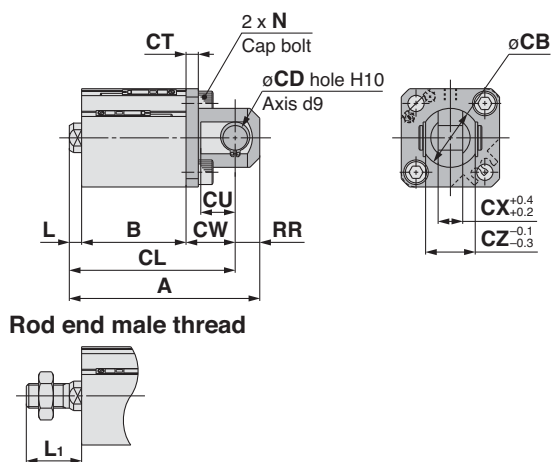

Double Clevis

Bore size (mm)	(mm)										
	A		B		CB	CD	CL		CT	CU	CW
	5st	10st	5st	10st			5st	10st			
12	56.5	61.5	33	38	12	5	50.5	55.5	4	7	14
16	60	65	35.5	40.5	14	5	54	59	4	10	15
20	68	73	36.5	41.5	20	8	59	64	5	12	18
25	72.5	77.5	37.5	42.5	24	10	62.5	67.5	5	14	20

Bore size (mm)	CX	CZ	L	L ₁	N	RR
12	5	10	3.5	14	M4 x 0.7	6
16	6.5	12	3.5	15.5	M4 x 0.7	6
20	8	16	4.5	18.5	M6 x 1.0	9
25	10	20	5	22.5	M6 x 1.0	10

Double clevis bracket material: Carbon steel
Surface treatment: Nickel plated

- * For details about the rod end nut and accessory brackets, refer to page 23.
- * Double clevis pin and retaining rings are included.

Standard

Large Bore Size

Long Stroke

Non-rotating Rod

Axial Piping

Anti-lateral Load

With End Lock

Water Resistant

With Auto Switch

Auto Switch

Made to Order

Series CQ2

Dimensions

ø32 to ø50/Spring Return With Auto Switch

(In the case of without auto switches, the A, B, F and P dimensions will be only changed. Refer to the dimension table.)

Both ends tapped: CQ2A/CDQ2A

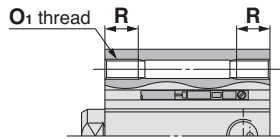

Both Ends Tapped (mm)

Bore size (mm)	O ₁	R
32	M6 x 1.0	10
40	M6 x 1.0	10
50	M8 x 1.25	14

Standard (Through-hole): CQ2B/CDQ2B

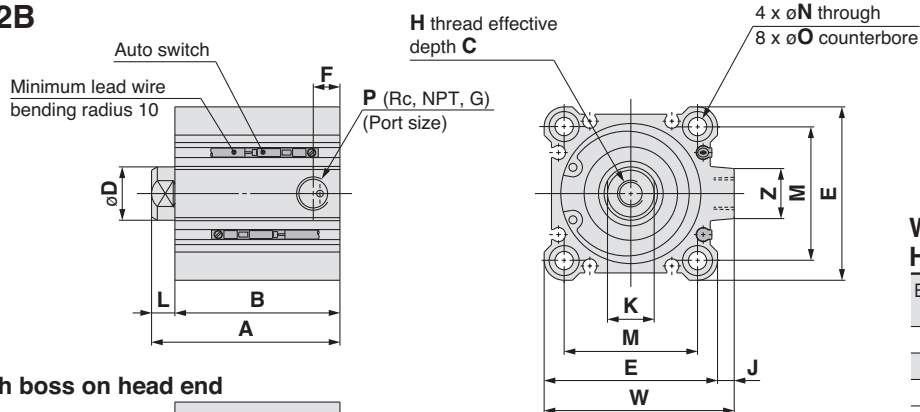

With Boss on Head End (mm)

Bore size (mm)	Th9
32	21 ⁰ _{-0.052}
40	28 ⁰ _{-0.052}
50	35 ⁰ _{-0.062}

Note 1) With boss on rod end:
Option (Suffix "-XC36" to the end of model number.)

With boss on head end

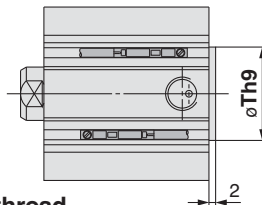

Rod end male thread

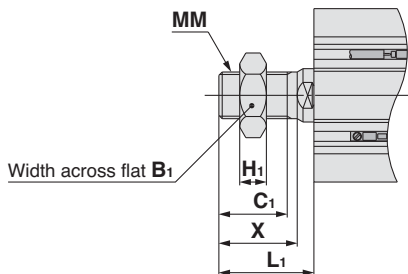

Rod End Male Thread (mm)

Bore size (mm)	B ₁	C ₁	H ₁	L ₁	MM	X
32	22	20.5	8	28.5	M14 x 1.5	23.5
40	22	20.5	8	28.5	M14 x 1.5	23.5
50	27	26	11	33.5	M18 x 1.5	28.5

Built-in one-touch fittings: ø32 to ø50

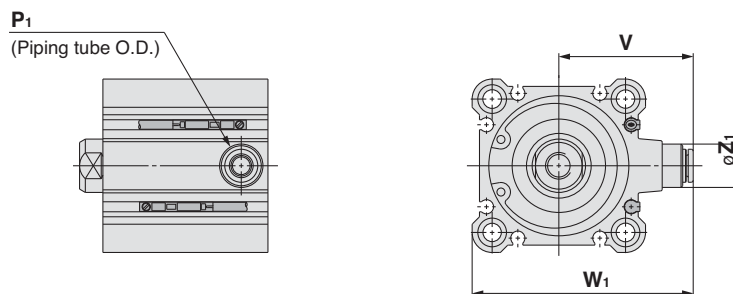

Built-in One-touch Fittings (mm)

Bore size (mm)	Z ₁	P ₁	V	W ₁
32	13	6	36.5	59
40	13	6	40.5	66.5
50	16	8	50	82

Standard For auto switch proper mounting position and its mounting height, refer to pages 193 to 199. (mm)

Bore size (mm)	Stroke (mm)	Without auto switch				With auto switch				C	D	E	H	J	K	L	M	N	O	W	Z
		A	B	F	P	A	B	F	P												
32	5	35	28	5.5	M5 x 0.8	45	38	7.5	1/8	13	16	45	M8 x 1.25	4.5	14	7	34	5.5	9 depth 7	49.5	14
	10	40	33	7.5	1/8	50	43														
40	5	41.5	34.5	7.5	1/8	51.5	44.5	7.5	1/8	13	16	52	M8 x 1.25	5	14	7	40	5.5	9 depth 7	57	15
	10	46.5	39.5	7.5		56.5	49.5														
50	10	48.5	40.5	10.5	1/4	58.5	50.5	10.5	1/4	15	20	64	M10 x 1.5	7	17	8	50	6.6	11 depth 8	71	19
	20	58.5	50.5	10.5		68.5	60.5														

Note 2) The A, B dimensions of the ø32-5 mm stroke with built-in one-touch fittings without auto switch are the same as those of the ø32-10 mm stroke without auto switch.

* For details about the rod end nut and accessory brackets, refer to page 23.

Foot: CQ2L/CDQ2L

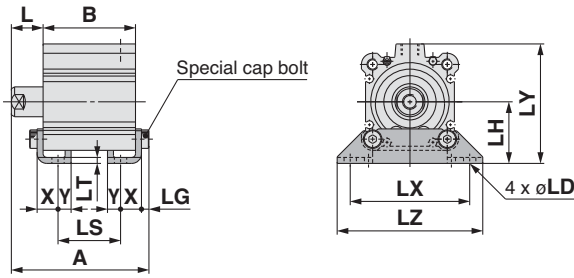

Rod end male thread

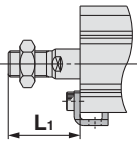

Compact foot: CQ2LC/CDQ2LC

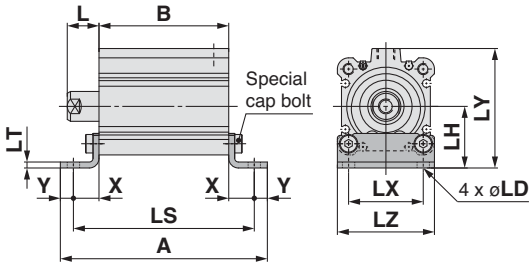

Rod end male thread

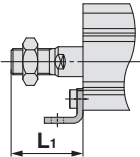

Rod flange: CQ2F/CDQ2F

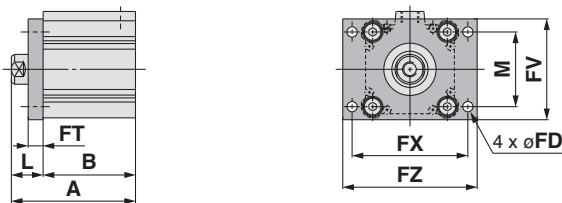

Rod end male thread

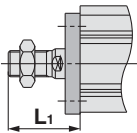

Head flange: CQ2G/CDQ2G

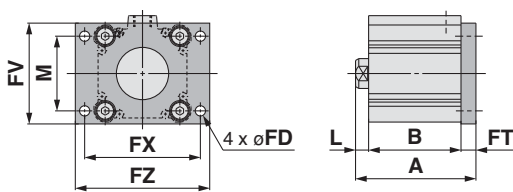

Rod end male thread

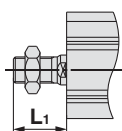

Foot

(mm)

Bore size (mm)	Without auto switch									With auto switch								
	A			B			LS			A			B			LS		
32	52.2	57.2	—	28	33	—	12	17	—	62.2	67.2	—	38	43	—	22	27	—
40	58.7	63.7	—	34.5	39.5	—	18.5	23.5	—	68.7	73.7	—	44.5	49.5	—	28.5	33.5	—
50	—	66.7	76.7	—	40.5	50.5	—	17.5	27.5	—	76.7	86.7	—	50.5	60.5	—	27.5	37.5

Bore size (mm)	L	L ₁	LD	LG	LH	LX	LT	LY	LZ	X	Y
32	17	38.5	6.6	4	30	57	3.2	57	71	11.2	5.8
40	17	38.5	6.6	4	33	64	3.2	64	78	11.2	7
50	18	43.5	9	5	39	79	3.2	78	95	14.7	8

Foot bracket material: Carbon steel
Surface treatment: Nickel plated

Compact Foot

(mm)

Bore size (mm)	Without auto switch									With auto switch								
	A			B			LS			A			B			LS		
32	67	72	—	28	33	—	55.4	60.4	—	77	82	—	38	43	—	65.4	70.4	—
40	75.9	80.9	—	34.5	39.5	—	61.9	66.9	—	85.9	90.9	—	44.5	49.5	—	71.9	76.9	—
50	—	89.9	99.9	—	40.5	50.5	—	73.9	83.9	—	99.9	109.9	—	50.5	60.5	—	83.9	93.9

Bore size (mm)	L	L ₁	LD	LH	LT	LX	LY	LZ	X	Y
32	17	38.5	6.6	30	3.2	34	57	45	13.7	5.8
40	17	38.5	6.6	33	3.2	40	64	52	13.7	7
50	18	43.5	9	39	3.2	50	78	64	16.7	8

Compact foot bracket material: Carbon steel
Surface treatment: Zinc chromated

Rod Flange

(mm)

Bore size (mm)	Without auto switch						With auto switch					
	A			B			A			B		
32	45	50	—	28	33	—	55	60	—	38	43	—
40	51.5	56.5	—	34.5	39.5	—	61.5	66.5	—	44.5	49.5	—
50	—	58.5	68.5	—	40.5	50.5	—	68.5	78.5	—	50.5	60.5

Bore size (mm)	FD	FT	FV	FX	FZ	L	L ₁	M
32	5.5	8	48	56	65	17	38.5	34
40	5.5	8	54	62	72	17	38.5	40
50	6.6	9	67	76	89	18	43.5	50

Flange bracket material: Carbon steel
Surface treatment: Nickel plated

Head Flange

(mm)

Bore size (mm)	Without auto switch						With auto switch					
	A			A			L			L ₁		
32	43	48	—	53	58	—	7	28.5	—	—	—	
40	49.5	54.5	—	59.5	64.5	—	7	28.5	—	—	—	
50	—	57.5	67.5	—	67.5	77.5	8	33.5	—	—	—	

Flange bracket material: Carbon steel
Surface treatment: Nickel plated

(* The dimensions except A, L and L₁ are the same as those of the rod flange.)

Standard

Large Bore Size

Long Stroke

Non-rotating Rod

Axial Piping

Anti-lateral Load

With End Lock

Water Resistant

With Auto Switch

Auto Switch

Made to Order

Double clevis: CQ2D/CDQ2D

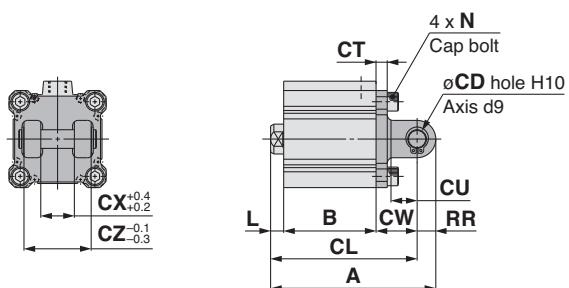

Rod end male thread

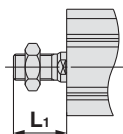

Double Clevis

(mm)

Bore size (mm)	Without auto switch									With auto switch									
	A			B			CL			A			B			CL			
	5st	10st	20st	5st	10st	20st	5st	10st	20st	5st	10st	20st	5st	10st	20st	5st	10st	20st	
32	65	70	—	28	33	—	55	60	—	75	80	—	38	43	—	65	70	—	
40	73.5	78.5	—	34.5	39.5	—	63.5	68.5	—	83.5	88.5	—	44.5	49.5	—	73.5	78.5	—	
50	—	90.5	100.5	—	40.5	50.5	—	76.5	86.5	—	100.5	110.5	—	50.5	60.5	—	86.5	96.5	—

Bore size (mm)	CD	CT	CU	CW	CX	CZ	L	L ₁	N	RR
32	10	5	14	20	18	36	7	28.5	M6 x 1.0	10
40	10	6	14	22	18	36	7	28.5	M6 x 1.0	10
50	14	7	20	28	22	44	8	33.5	M8 x 1.25	14

Double clevis bracket material: Cast iron
Surface treatment: Painted

- * For details about the rod end nut and accessory brackets, refer to page 23.
- * Double clevis pin and retaining rings are included.

Series CQ2

Dimensions

Ø12 to Ø25/Spring Extend Without Auto Switch

Both ends tapped: CQ2A

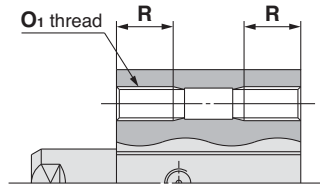

Both Ends Tapped (mm)

Bore size (mm)	O ₁	R
12	M4 x 0.7	7
16	M4 x 0.7	7
20	M6 x 1.0	10
25	M6 x 1.0	10

Standard (Through-hole): CQ2B

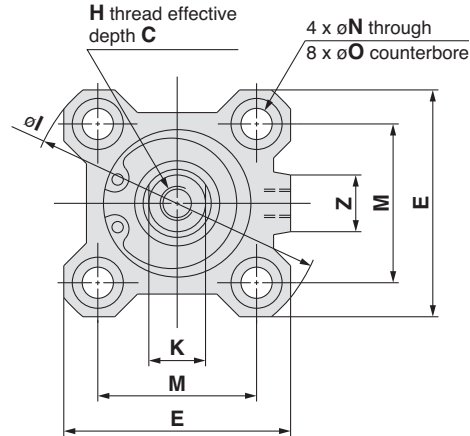
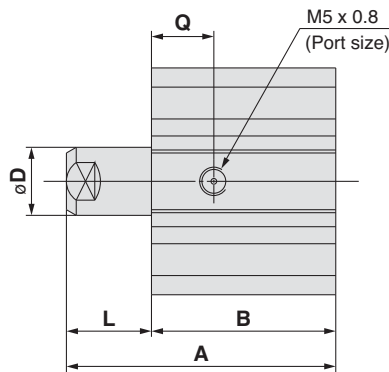

With boss on head side

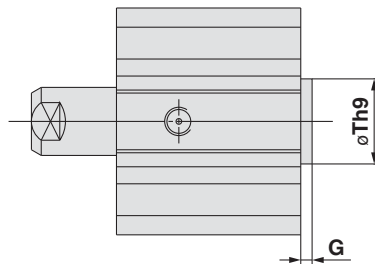

With Boss on Head Side (mm)

Bore size (mm)	G	Th9
12	1.5	15 ⁰ _{-0.043}
16	1.5	20 ⁰ _{-0.052}
20	2	13 ⁰ _{-0.043}
25	2	15 ⁰ _{-0.043}

Note) With boss on rod cover side: Option (Suffix "-XC36" to the end of model number.)

Rod end male thread

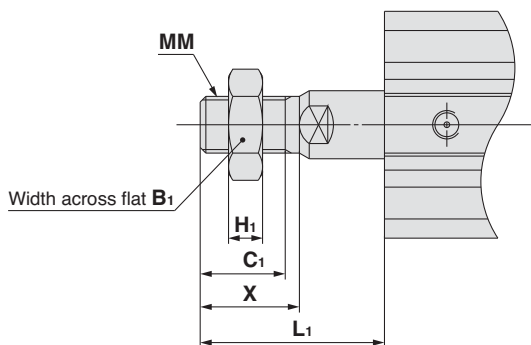

Rod End Male Thread (mm)

Bore size (mm)	B ₁	C ₁	H ₁	L ₁		MM	X
				5st	10st		
12	8	9	4	19	24	M5 x 0.8	10.5
16	10	10	5	20.5	25.5	M6 x 1.0	12
20	13	12	5	23.5	28.5	M8 x 1.25	14
25	17	15	6	27.5	32.5	M10 x 1.25	17.5

Standard

Bore size (mm)	Stroke (mm)	A	B	C	D	E	H	I	K	L	M	N	O	Q	Z
12	5	30.5	22	6	6	25	M3 x 0.5	32	5	8.5	15.5	3.5	6.5 depth 3.5	7.5	—
	10	40.5	27							13.5					
16	5	32	23.5	8	8	29	M4 x 0.7	38	6	8.5	20	3.5	6.5 depth 3.5	8	10
	10	42	28.5							13.5					
20	5	34	24.5	7	10	36	M5 x 0.8	47	8	9.5	25.5	5.5	9 depth 7	8	10
	10	44	29.5							14.5					
25	5	37.5	27.5	12	12	40	M6 x 1.0	52	10	10	28	5.5	9 depth 7	9	10
	10	47.5	32.5							15					

* For details about the rod end nut and accessory brackets, refer to page 23.

Compact Cylinder: Standard Single Acting, Single Rod *Series CQ2*

Foot: CQ2L

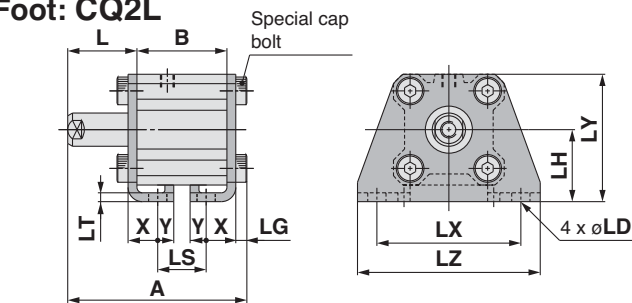

Rod end male thread

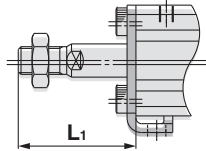

Compact foot: CQ2LC

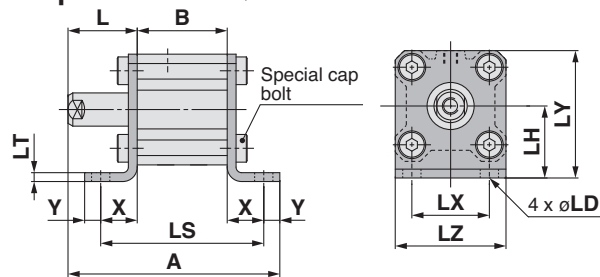

Rod end male thread

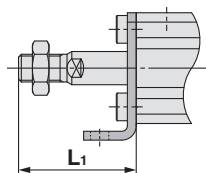

Rod flange: CQ2F

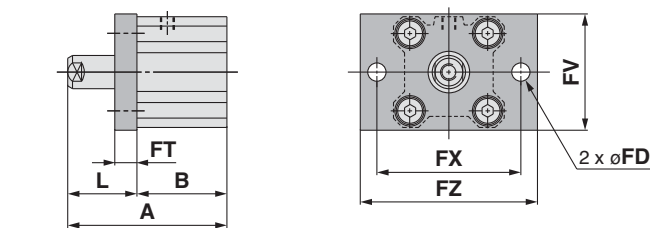

Rod end male thread

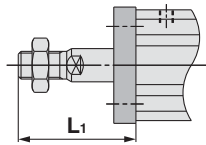

Head flange: CQ2G

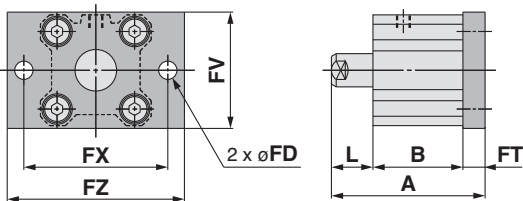

Rod end male thread

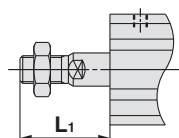

Foot

(mm)

Bore size (mm)	A		B		L		L ₁		LD	LG	LH	LS	
	5st	10st	5st	10st	5st	10st	5st	10st				5st	10st
12	45.3	55.3	22	27	18.5	23.5	29	34	4.5	2.8	17	10	15
16	46.8	56.8	23.5	28.5	18.5	23.5	30.5	35.5	4.5	2.8	19	11.5	16.5
20	51.2	61.2	24.5	29.5	19.5	24.5	33.5	38.5	6.6	4	24	12.5	17.5
25	54.7	64.7	27.5	32.5	20	25	37.5	42.5	6.6	4	26	12.5	17.5

Bore size (mm)	LT	LX	LY	LZ	X	Y
12	2	34	29.5	44	8	4.5
16	2	38	33.5	48	8	5
20	3.2	48	42	62	9.2	5.8
25	3.2	52	46	66	10.7	5.8

Foot bracket material: Carbon steel
Surface treatment: Nickel plated

Compact Foot

(mm)

Bore size (mm)	A		B		L		L ₁		LD	LH	LS		LT
	5st	10st	5st	10st	5st	10st	5st	10st			5st	10st	
12	54.3	64.3	22	27	18.5	23.5	29	34	4.5	17	40.6	45.6	2
16	56.3	66.3	23.5	28.5	18.5	23.5	30.5	35.5	4.5	19	42.1	47.1	2
20	63	73	24.5	29.5	19.5	24.5	33.5	38.5	6.6	24	50.9	55.9	3.2
25	66.5	76.5	27.5	32.5	20	25	37.5	42.5	6.6	26	53.9	58.9	3.2

Bore size (mm)	LX	LY	LZ	X	Y
12	15.5	29.5	25	9.3	4.5
16	20	33.5	29	9.3	5
20	25.5	42	36	13.2	5.8
25	28	46	40	13.2	5.8

Compact foot bracket material: Carbon steel
Surface treatment: Zinc chromated

Rod Flange

(mm)

Bore size (mm)	A		B		FD	FT	FV	FX	FZ	L		L ₁	
	5st	10st	5st	10st						5st	10st	5st	10st
12	40.5	50.5	22	27	4.5	5.5	25	45	55	18.5	23.5	29	34
16	42	52	23.5	28.5	4.5	5.5	30	45	55	18.5	23.5	30.5	35.5
20	44	54	24.5	29.5	6.6	8	39	48	60	19.5	24.5	33.5	38.5
25	47.5	57.5	27.5	32.5	6.6	8	42	52	64	20	25	37.5	42.5

Flange bracket material: Carbon steel
Surface treatment: Nickel plated

Head Flange

(mm)

Bore size (mm)	A		L		L ₁	
	5st	10st	5st	10st	5st	10st
12	36	46	8.5	13.5	19	24
16	37.5	47.5	8.5	13.5	20.5	25.5
20	42	52	9.5	14.5	23.5	28.5
25	45.5	55.5	10	15	27.5	32.5

Flange bracket material: Carbon steel
Surface treatment: Nickel plated

* The dimensions except A, L and L₁ are the same as those of the rod flange.

Double clevis: CQ2D

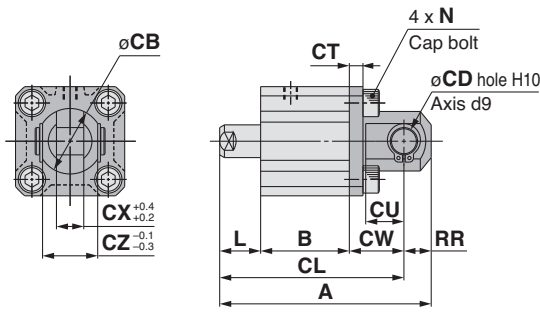

Rod end male thread

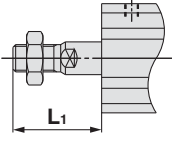

Double Clevis

Bore size (mm)	A		B		CB	CD	CL		CT	CU	CW	CX	CZ
	5st	10st	5st	10st			5st	10st					
12	50.5	60.5	22	27	12	5	44.5	54.5	4	7	14	5	10
16	53	63	23.5	28.5	14	5	47	57	4	10	15	6.5	12
20	61	71	24.5	29.5	20	8	52	62	5	12	18	8	16
25	67.5	77.5	27.5	32.5	24	10	57.5	67.5	5	14	20	10	20

Bore size (mm)	L		L ₁		N	RR
	5st	10st	5st	10st		
12	8.5	13.5	19	24	M4 x 0.7	6
16	8.5	13.5	20.5	25.5	M4 x 0.7	6
20	9.5	14.5	23.5	28.5	M6 x 1.0	9
25	10	15	27.5	32.5	M6 x 1.0	10

Double clevis bracket material: Carbon steel
Surface treatment: Nickel plated

* For details about the rod end nut and accessory brackets, refer to page 23.
* Double clevis pin and retaining rings are included.

Standard

Large Bore Size

Long Stroke

Non-rotating Rod

Axial Piping

Anti-lateral Load

With End Lock

Water Resistant

With Auto Switch

Auto Switch

Made to Order

Series CQ2

Dimensions

Ø12 to Ø25/Spring Extend With Auto Switch

Both ends tapped: CDQ2A

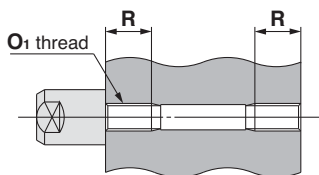

Both Ends Tapped (mm)

Bore size (mm)	O ₁	R
12	M4 x 0.7	7
16	M4 x 0.7	7
20	M6 x 1.0	10
25	M6 x 1.0	10

Standard (Through-hole): CDQ2B

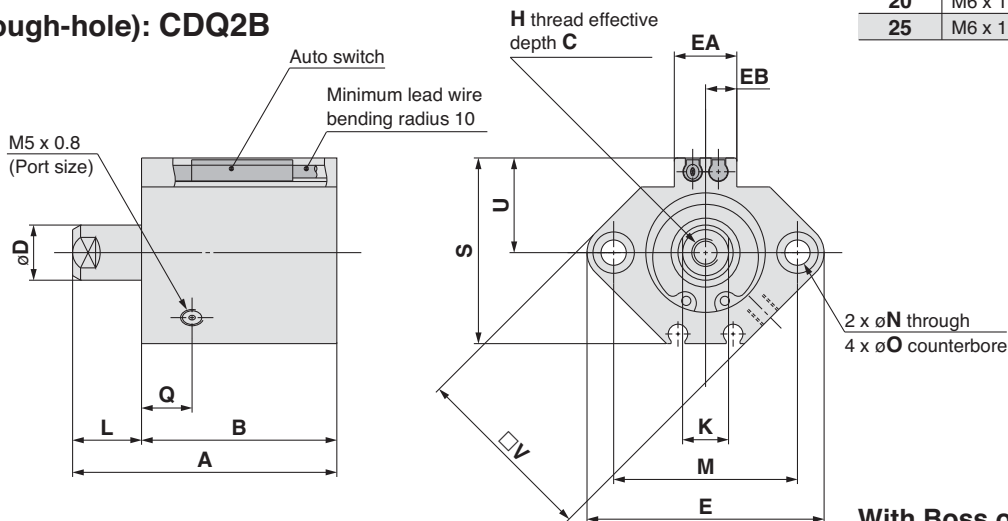

With boss on head end

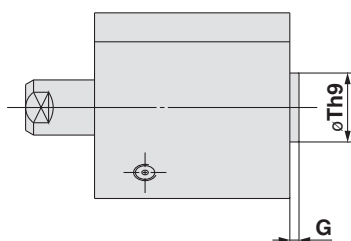

Ø16 to Ø25

With Boss on Head End (mm)

Bore size (mm)	G	Th9
12	1.5	15 ⁰ _{-0.043}
16	1.5	20 ⁰ _{-0.052}
20	2	13 ⁰ _{-0.043}
25	2	15 ⁰ _{-0.043}

Note) With boss on rod end: Option (Suffix "-XC36" to the end of model number.)

Rod end male thread

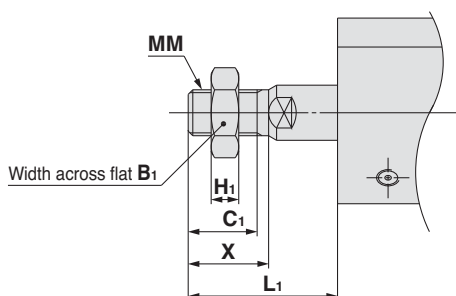

Ø12 Rod End Male Thread (mm)

Bore size (mm)	B ₁	C ₁	H ₁	L ₁		MM	X
				5st	10st		
12	8	9	4	19	24	M5 x 0.8	10.5
16	10	10	5	20.5	25.5	M6 x 1.0	12
20	13	12	5	23.5	28.5	M8 x 1.25	14
25	17	15	6	27.5	32.5	M10 x 1.25	17.5

Standard For auto switch proper mounting position and its mounting height, refer to pages 193 to 199.

Bore size (mm)	Stroke (mm)	A	B	C	D	E	EA	EB	H	K	L	M	N	O	Q	S	U	V
12	5	45.9	37.4	6	6	33	—	—	M3 x 0.5	5	8.5	22	3.5	6.5 depth 3.5	11	27.5	14	25
	10	55.9	42.4	6	6	33	—	—	M3 x 0.5	5	13.5	22	3.5	6.5 depth 3.5	11	27.5	14	25
16	5	44	35.5	8	8	37	13.2	6.6	M4 x 0.7	6	8.5	28	3.5	6.5 depth 3.5	10	29.5	15	29
	10	54	40.5	8	8	37	13.2	6.6	M4 x 0.7	6	13.5	28	3.5	6.5 depth 3.5	10	29.5	15	29
20	5	46	36.5	7	10	47	13.6	6.8	M5 x 0.8	8	9.5	36	5.5	9 depth 7	8	35.5	18	36
	10	56	41.5	7	10	47	13.6	6.8	M5 x 0.8	8	14.5	36	5.5	9 depth 7	8	35.5	18	36
25	5	47.5	37.5	12	12	52	13.6	6.8	M6 x 1.0	10	10	40	5.5	9 depth 7	9	40.5	21	40
	10	57.5	42.5	12	12	52	13.6	6.8	M6 x 1.0	10	15	40	5.5	9 depth 7	9	40.5	21	40

* For details about the rod end nut and accessory brackets, refer to page 23.

Foot: CDQ2L

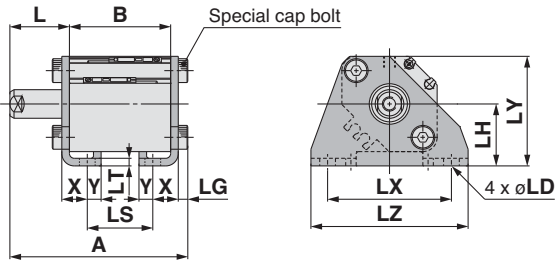

Rod end male thread

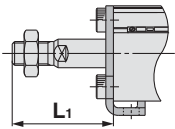

Compact foot: CDQ2LC

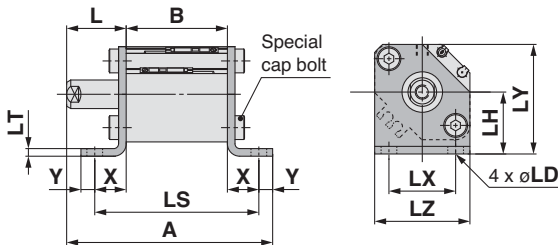

Rod end male thread

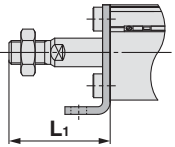

Rod flange: CDQ2F

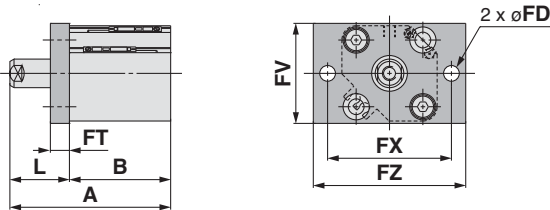

Rod end male thread

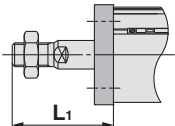

Head flange: CDQ2G

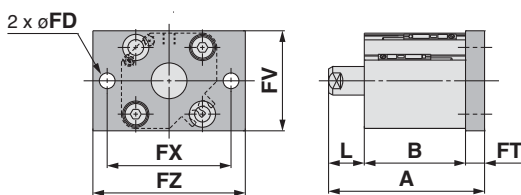

Rod end male thread

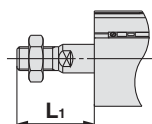

Foot

Bore size (mm)	A		B		L		L ₁		LD	LG	LH	LS	
	5st	10st	5st	10st	5st	10st	5st	10st				5st	10st
12	60.7	70.7	37.4	42.4	18.5	23.5	29	34	4.5	2.8	17	25.4	30.4
16	58.8	68.8	35.5	40.5	18.5	23.5	30.5	35.5	4.5	2.8	19	23.5	28.5
20	63.2	73.2	36.5	41.5	19.5	24.5	33.5	38.5	6.6	4	24	24.5	29.5
25	64.7	74.7	37.5	42.5	20	25	37.5	42.5	6.6	4	26	22.5	27.5

Bore size (mm)	LT	LX	LY	LZ	X	Y
12	2	34	29.5	44	8	4.5
16	2	38	33.5	48	8	5
20	3.2	48	42	62	9.2	5.8
25	3.2	52	46	66	10.7	5.8

Foot bracket material: Carbon steel
Surface treatment: Nickel plated

Compact Foot

Bore size (mm)	A		B		L		L ₁		LD	LH	LS		LT
	5st	10st	5st	10st	5st	10st	5st	10st			5st	10st	
12	69.7	79.7	37.4	42.4	18.5	23.5	29	34	4.5	17	56	61	2
16	68.3	78.3	35.5	40.5	18.5	23.5	30.5	35.5	4.5	19	54.1	59.1	2
20	75	85	36.5	41.5	19.5	24.5	33.5	38.5	6.6	24	62.9	67.9	3.2
25	76.5	86.5	37.5	42.5	20	25	37.5	42.5	6.6	26	63.9	68.9	3.2

Bore size (mm)	LX	LY	LZ	X	Y
12	15.5	29.5	25	9.3	4.5
16	20	33.5	29	9.3	5
20	25.5	42	36	13.2	5.8
25	28	46	40	13.2	5.8

Compact foot bracket material: Carbon steel
Surface treatment: Zinc chromated

Rod Flange

Bore size (mm)	A		B		FD	FT	FV	FX	FZ	L		L ₁	
	5st	10st	5st	10st						5st	10st	5st	10st
12	55.9	65.9	37.4	42.4	4.5	5.5	25	45	55	18.5	23.5	29	34
16	54	64	35.5	40.5	4.5	5.5	30	45	55	18.5	23.5	30.5	35.5
20	56	66	36.5	41.5	6.6	8	39	48	60	19.5	24.5	33.5	38.5
25	57.5	67.5	37.5	42.5	6.6	8	42	52	64	20	25	37.5	42.5

Flange bracket material: Carbon steel
Surface treatment: Nickel plated

Head Flange

Bore size (mm)	A		L		L ₁	
	5st	10st	5st	10st	5st	10st
12	51.4	61.4	8.5	13.5	19	24
16	49.5	59.5	8.5	13.5	20.5	25.5
20	54	64	9.5	14.5	23.5	28.5
25	55.5	65.5	10	15	27.5	32.5

Flange bracket material: Carbon steel
Surface treatment: Nickel plated

(* The dimensions except A, L and L₁ are the same as those of the rod flange.

Standard

Large Bore Size

Long Stroke

Non-rotating Rod

Axial Piping

Anti-lateral Load

With End Lock

Water Resistant

With Auto Switch

Auto Switch

Made to Order

Compact Cylinder: Standard Single Acting, Single Rod **Series CQ2**

Double clevis: CDQ2D

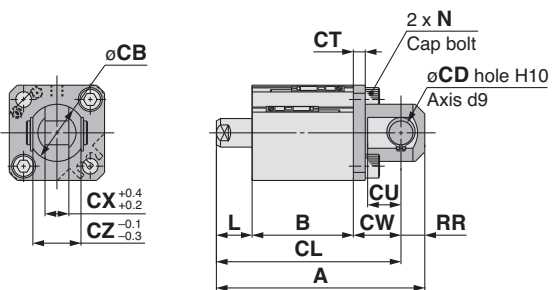

Rod end male thread

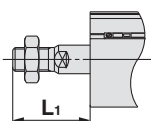

Double Clevis

(mm)

Bore size (mm)	A		B		CB	CD	CL		CT	CU	CW	CX	CZ
	5st	10st	5st	10st			5st	10st					
12	65.9	75.9	37.4	42.4	12	5	59.9	69.9	4	7	14	5	10
16	65	75	35.5	40.5	14	5	59	69	4	10	15	6.5	12
20	73	83	36.5	41.5	20	8	64	74	5	12	18	8	16
25	77.5	87.5	37.5	42.5	24	10	67.5	77.5	5	14	20	10	20

Bore size (mm)	L		L ₁		N	RR
	5st	10st	5st	10st		
12	8.5	13.5	19	24	M4 x 0.7	6
16	8.5	13.5	20.5	25.5	M4 x 0.7	6
20	9.5	14.5	23.5	28.5	M6 x 1.0	9
25	10	15	27.5	32.5	M6 x 1.0	10

Double clevis bracket material:
Carbon steel
Surface treatment:
Nickel plated

- * For details about the rod end nut and accessory brackets, refer to page 23.
- * Double clevis pin and retaining rings are included.

Series CQ2

Dimensions

ø32 to ø50/Spring Extend With Auto Switch

(In the case of without auto switches, the A, B, P and Q dimensions will be only changed. Refer to the dimension table.)

Both ends tapped: CQ2A/CDQ2A

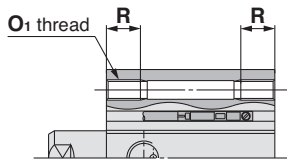

Both Ends

Tapped (mm)

Bore size (mm)	O ₁	R
32	M6 x 1.0	10
40	M6 x 1.0	10
50	M8 x 1.25	14

Standard (Through-hole): CQ2B/CDQ2B

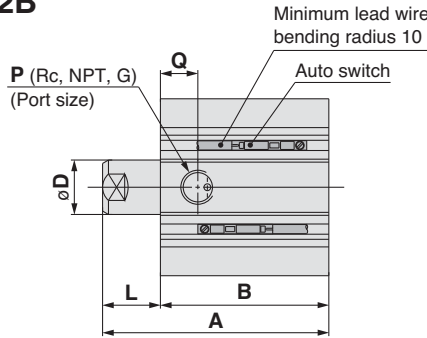

With boss on head end

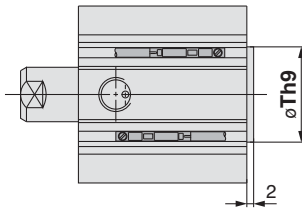

Rod end male thread

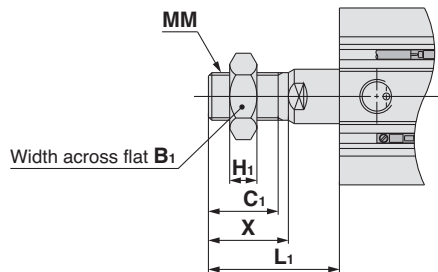

H thread effective depth C

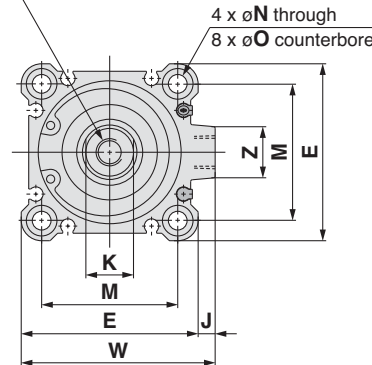

With Boss on Head End (mm)

Bore size (mm)	Th9
32	21 ⁰ _{-0.052}
40	28 ⁰ _{-0.052}
50	35 ⁰ _{-0.062}

Note) With boss on rod end: Option (Suffix "-XC36" to the end of model number.)

Rod End Male Thread (mm)

Bore size (mm)	B ₁	C ₁	H ₁	L ₁			MM	X
				5st	10st	20st		
32	22	20.5	8	33.5	38.5	—	M14 x 1.5	23.5
40	22	20.5	8	33.5	38.5	—	M14 x 1.5	23.5
50	27	26	11	—	43.5	53.5	M18 x 1.5	28.5

Built-in one-touch fittings: ø32 to ø50

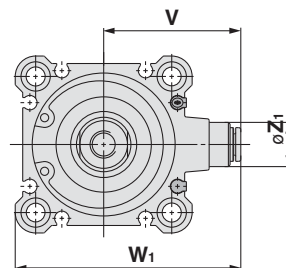
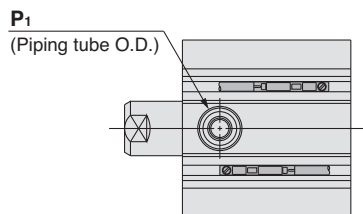

Built-in One-touch Fittings (mm)

Bore size (mm)	Z ₁	P ₁	V	W ₁
32	13	6	36.5	59
40	13	6	40.5	66.5
50	16	8	50	82

Standard For auto switch proper mounting position and its mounting height, refer to pages 193 to 199.

Bore size (mm)	Stroke (mm)	Without auto switch				With auto switch				C	D	E	H	J	K	L	M	N	O	W	Z	
		A	B	P	Q	A	B	P	Q													
32	5	40	28	M5 x 0.8	10	50	38									12						
	10	50	33	1/8	10	60	43	1/8	10	13	16	45	M8 x 1.25	4.5	14	17	34	5.5	9 depth 7	49.5	14	
40	5	46.5	34.5			56.5	44.5									12						
	10	56.5	39.5	1/8	12.5	66.5	49.5	1/8	12.5	13	16	52	M8 x 1.25	5	14	17	40	5.5	9 depth 7	57	15	
50	10	58.5	40.5			68.5	50.5									18						
	20	78.5	50.5	1/4	10.5	88.5	60.5	1/4	10.5	15	20	64	M10 x 1.5	7	17	28	50	6.6	11 depth 8	71	19	

* For details about the rod end nut and accessory brackets, refer to page 23.

Compact Cylinder: Standard Single Acting, Single Rod **Series CQ2**

Foot: CQ2L/CDQ2L

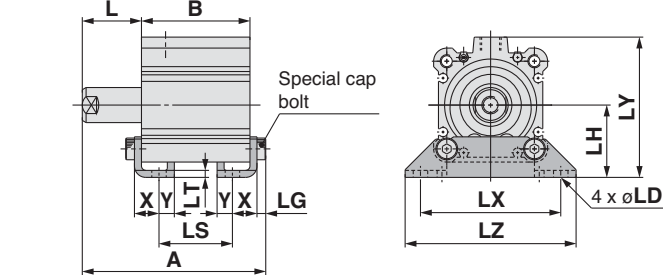

Rod end male thread

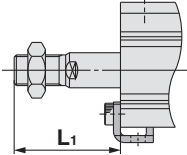

Compact foot: CQ2LC/CDQ2LC

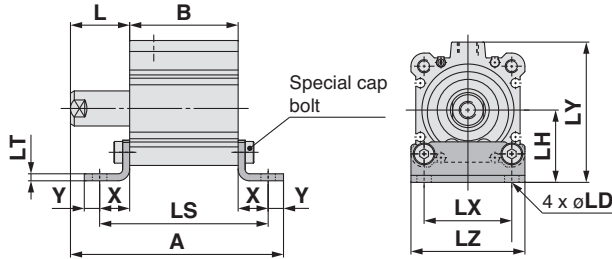

Rod end male thread

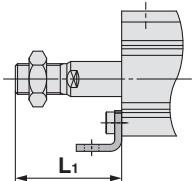

Rod flange: CQ2F/CDQ2F

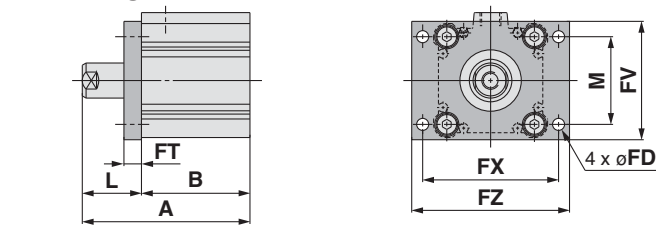

Rod end male thread

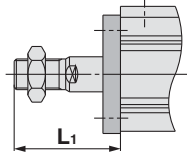

Head flange: CQ2G/CDQ2G

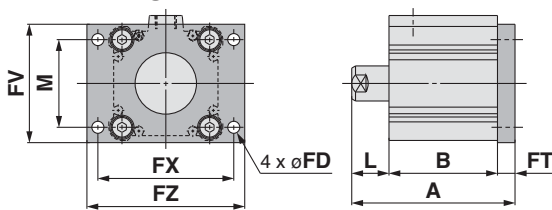

Rod end male thread

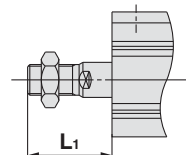

Foot

(mm)

Bore size (mm)	Without auto switch									With auto switch									
	A			B			LS			A			B			LS			
	5st	10st	20st	5st	10st	20st	5st	10st	20st	5st	10st	20st	5st	10st	20st	5st	10st	20st	
32	57.2	67.2	-	28	33	-	12	17	-	67.2	77.2	-	38	43	-	22	27	-	
40	63.7	73.7	-	34.5	39.5	-	18.5	23.5	-	73.7	83.7	-	44.5	49.5	-	28.5	33.5	-	
50	-	76.7	96.7	-	40.5	50.5	-	17.5	27.5	-	86.7	106.7	-	50.5	60.5	-	27.5	37.5	-

Bore size (mm)	L			L ₁			LD	LG	LH	LT	LX	LY	LZ	X	Y
	5st	10st	20st	5st	10st	20st									
	32	22	27	-	43.5	48.5									
40	22	27	-	43.5	48.5	-	6.6	4	33	3.2	64	64	78	11.2	7
50	-	28	38	-	53.5	63.5	9	5	39	3.2	79	78	95	14.7	8

Foot bracket material: Carbon steel
Surface treatment: Nickel plated

Compact Foot

(mm)

Bore size (mm)	Without auto switch									With auto switch									
	A			B			LS			A			B			LS			
	5st	10st	20st	5st	10st	20st	5st	10st	20st	5st	10st	20st	5st	10st	20st	5st	10st	20st	
32	69.5	79.5	-	28	33	-	55.4	60.4	-	79.5	89.5	-	38	43	-	65.4	70.4	-	
40	77.2	87.2	-	34.5	39.5	-	61.9	66.9	-	87.2	97.2	-	44.5	49.5	-	71.9	76.9	-	
50	-	93.2	113.2	-	40.5	50.5	-	73.9	83.9	-	103.2	123.2	-	50.5	60.5	-	83.9	93.9	-

Bore size (mm)	L			L ₁			LD	LH	LT	LX	LY	LZ	X	Y
	5st	10st	20st	5st	10st	20st								
	32	22	27	-	43.5	48.5								
40	22	27	-	43.5	48.5	-	6.6	33	3.2	40	64	52	13.7	7
50	-	28	38	-	53.5	63.5	9	39	3.2	50	78	64	16.7	8

Compact foot bracket material: Carbon steel
Surface treatment: Zinc chromated

Rod Flange

(mm)

Bore size (mm)	Without auto switch									With auto switch								
	A			B			A			B			FD	FT	FV	FX	FZ	
	5st	10st	20st	5st	10st	20st	5st	10st	20st	5st	10st	20st						
32	50	60	-	28	33	-	60	70	-	38	43	-	5.5	8	45	56	65	
40	56.5	66.5	-	34.5	39.5	-	66.5	76.5	-	44.5	49.5	-	5.5	8	54	62	72	
50	-	68.5	88.5	-	40.5	50.5	-	78.5	98.5	-	50.5	60.5	6.6	9	67	76	89	

Bore size (mm)	L			L ₁			M
	5st	10st	20st	5st	10st	20st	
	32	22	27	-	43.5	48.5	
40	22	27	-	43.5	48.5	-	40
50	-	28	38	-	53.5	63.5	50

Flange bracket material: Carbon steel
Surface treatment: Nickel plated

Head Flange

(mm)

Bore size (mm)	Without auto switch			With auto switch			L			L ₁			
	A			A			L			L ₁			
	5st	10st	20st	5st	10st	20st	5st	10st	20st	5st	10st	20st	
32	48	58	-	58	68	-	12	17	-	33.5	38.5	-	
40	54.5	64.5	-	64.5	74.5	-	12	17	-	33.5	38.5	-	
50	-	67.5	87.5	-	77.5	97.5	-	18	28	-	43.5	53.5	-

(* The dimensions except A, L and L₁ are the same as those of the rod flange.)

Flange bracket material: Carbon steel
Surface treatment: Nickel plated

Double clevis: CQ2D/CDQ2D

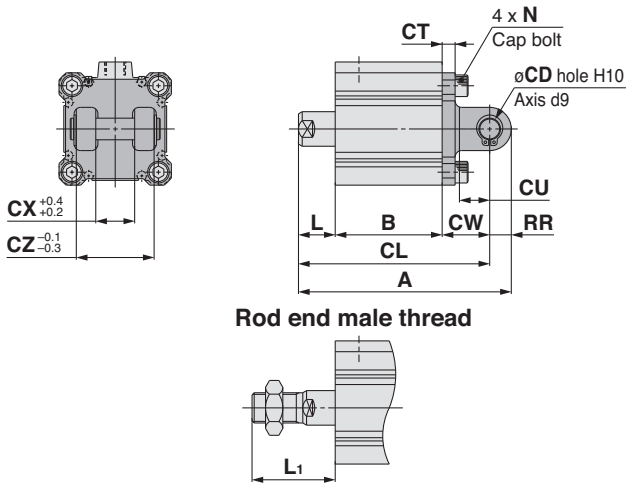

Rod end male thread

Double Clevis

(mm)

Bore size (mm)	Without auto switch									With auto switch								
	A			B			CL			A			B			CL		
32	5st	10st	20st	5st	10st	20st	5st	10st	20st	5st	10st	20st	5st	10st	20st	5st	10st	20st
32	70	80	-	28	33	-	60	70	-	80	90	-	38	43	-	70	80	-
40	78.5	88.5	-	34.5	39.5	-	68.5	78.5	-	88.5	98.5	-	44.5	49.5	-	78.5	88.5	-
50	-	100.5	120.5	-	40.5	50.5	-	86.5	106.5	-	110.5	130.5	-	50.5	60.5	-	96.5	116.5

Bore size (mm)	CD	CT	CU	CW	CX	CZ	L			L ₁			N	RR
							5st	10st	20st	5st	10st	20st		
32	10	5	14	20	18	36	12	17	-	33.5	38.5	-	M6 x 1.0	10
40	10	6	14	22	18	36	12	17	-	33.5	38.5	-	M6 x 1.0	10
50	14	7	20	28	22	44	-	18	28	-	43.5	53.5	M8 x 1.25	14

Double clevis bracket material: Cast iron
Surface treatment: Painted

- * For details about the rod end nut and accessory brackets, refer to page 23.
- * Double clevis pin and retaining rings are included.

Standard

Large Bore Size

Long Stroke

Non-rotating Rod

Axial Piping

Anti-lateral Load

With End Lock

Water Resistant

With Auto Switch

Auto Switch

Made to Order

Compact Cylinder: Large Bore Size Double Acting, Single Rod Series CQ2

ø125, ø140, ø160, ø180, ø200

How to Order

Without auto switch

CQ2B 125 - 30 DC Z

With auto switch

CDQ2B 125 - 30 DC Z M9BW

With auto switch
(Built-in magnet)

Mounting

B Through-hole/Both ends tapped common (Standard)

* Cylinder mounting bolts are not included. Order them separately referring to "Mounting Bolt for CQ2B" on page 73.

Bore size

125	125 mm
140	140 mm
160	160 mm
180	180 mm
200	200 mm

Port thread type

—	Rc
TN	NPT
TF	G

Cylinder stroke (mm)

Refer to the next page for standard strokes.

Action

D Double acting

Made to Order
Refer to the next page for details.

Number of auto switches

—	2 pcs.
S	1 pc.
n	"n" pcs.

Auto switch

— Without auto switch

* Refer to the below table for applicable auto switches.

Auto switch mounting groove

Z ø125 to ø200 4 surfaces

Body option

—	Standard (Rod end female thread)
M	Rod end male thread

Cushion

C Rubber bumper

Built-in Magnet Cylinder Model

If a built-in magnet cylinder without an auto switch is required, there is no need to enter the symbol for the auto switch.

(Example) CDQ2B140-30DCZ

Applicable Auto Switches/Refer to pages 1263 to 1371 in Best Pneumatics No. 2 for further information on auto switches.

Type	Special function	Electrical entry	Indicator light	Wiring (Output)	Load voltage		Auto switch model		Lead wire length (m)					Pre-wired connector	Applicable load			
					DC	AC	Perpendicular	In-line	0.5 (-)	1 (M)	3 (L)	5 (Z)	None (N)		IC circuit	Relay, PLC		
Solid state auto switch	—	Grommet	Yes	3-wire (NPN)	24 V	5 V, 12 V	—	M9NV	M9N	●	●	●	○	—	○	IC circuit	Relay, PLC	
				3-wire (PNP)				M9PV	M9P	●	●	●	○	—	○			
				2-wire				M9BV	M9B	●	●	●	○	—	○			
	Diagnostic indication (2-colour indication)			3-wire (NPN)				M9NWV	M9NW	●	●	●	○	—	○			IC circuit
				3-wire (PNP)				M9P WV	M9P W	●	●	●	○	—	○			
				2-wire				M9B WV	M9B W	●	●	●	○	—	○			
	Water resistant (2-colour indication)			3-wire (NPN)				M9NAV**	M9NA**	○	○	●	○	—	○			IC circuit
				3-wire (PNP)				M9PAV**	M9PA**	○	○	●	○	—	○			
				2-wire				M9BAV**	M9BA**	○	○	●	○	—	○			
Reed auto switch	—	Grommet	Yes	3-wire (NPN equivalent)	24 V	5 V	—	A96V	A96	●	—	●	—	—	—	IC circuit	—	
				2-wire				A93V	A93	●	—	●	—	—	—	—	—	Relay, PLC
								A90V	A90	●	—	●	—	—	—	—	—	IC circuit

** Water resistant type auto switches can be mounted on the above models, but in such case SMC cannot guarantee water resistance. Consult with SMC regarding water resistant types with the above model numbers.

* Lead wire length symbols: 0.5 m — (Example) M9NW
1 m M (Example) M9NWM
3 m L (Example) M9NWL
5 m Z (Example) M9NWZ

* Solid state auto switches marked with "○" are produced upon receipt of order.

* There are other applicable auto switches other than the listed above. For details, refer to page 199.

* For details about auto switches with pre-wired connector, refer to pages 1328 and 1329 in Best Pneumatics No. 2.

Compact Cylinder: Large Bore Size Double Acting, Single Rod *Series CQ2*

Specifications



Symbol
Double acting,
Single rod

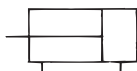

Made to Order
(For details, refer to pages 201 to 235.)

Symbol	Specifications
-XA□	Change of rod end shape
-XB10	Intermediate stroke (Exclusive body type)
-XC85	Grease for food processing equipment
-X271	Fluororubber seals, ø125 to ø160 only

Bore size (mm)	125	140	160	180	200
Action	Double acting, Single rod				
Fluid	Air				
Proof pressure	1.5 MPa			1.05 MPa	
Maximum operating pressure	1.0 MPa			0.7 MPa	
Minimum operating pressure	0.05 MPa				
Ambient and fluid temperature	Without auto switch: -10 to 70°C (No freezing) With auto switch: -10 to 60°C (No freezing)				
Lubrication	Not required (Non-lube)				
Piston speed	50 to 500 mm/s			20 to 400 mm/s	
Allowable kinetic energy (J)	7.4	9.8	12.4		
Stroke length tolerance	+1.4 mm (Note) 0				

Note) Stroke length tolerance does not include the amount of bumper change.

Standard Strokes

Bore size (mm)	Standard stroke (mm)
125, 140, 160 180, 200	10, 20, 30, 40, 50, 75, 100, 125, 150, 175, 200, 250, 300

Manufacture of Intermediate Strokes

Type	A spacer is installed in the standard stroke body.	Exclusive body (-XB10)								
Part no.	Refer to "How to Order" for the standard model number. (P. 71)	Suffix "-XB10" to the end of standard model number. (P. 71)								
Description	Strokes in 5 mm intervals are available by installing a spacer in the standard stroke cylinder.	Strokes in 1 mm intervals are available by using an exclusive body with the specified stroke.								
Stroke range	<table border="1"> <thead> <tr> <th>Bore size</th> <th>Stroke range</th> </tr> </thead> <tbody> <tr> <td>125 to 200</td> <td>5 to 295</td> </tr> </tbody> </table>	Bore size	Stroke range	125 to 200	5 to 295	<table border="1"> <thead> <tr> <th>Bore size</th> <th>Stroke range</th> </tr> </thead> <tbody> <tr> <td>125 to 200</td> <td>11 to 299</td> </tr> </tbody> </table>	Bore size	Stroke range	125 to 200	11 to 299
Bore size	Stroke range									
125 to 200	5 to 295									
Bore size	Stroke range									
125 to 200	11 to 299									
Example	Part no.: CQ2B160-165DCZ CQ2B160-175DCZ with 10 mm width spacer inside The B dimension is 266 mm.	Part no.: CQ2B160-165DCZ-XB10 Makes 165 mm stroke tube. The B dimension is 256 mm.								

Refer to pages 193 to 199 for the specifications of cylinders with autoswitches.

- Auto switch proper mounting position (detection at stroke end) and its mounting height
- Minimum stroke for auto switch mounting
- Operating range
- Auto switch mounting brackets/Part no.

Standard
Large Bore Size
Long Stroke
Non-rotating Rod
Axial Piping
Anti-lateral Load
With End Lock
Water Resistant
With Auto Switch
Auto Switch
Made to Order

Series CQ2

Theoretical Output

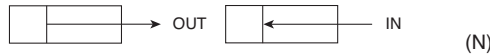

Bore size (mm)	Operating direction	Operating pressure (MPa)		
		0.3	0.5	0.7
125	IN	3376	5627	7878
	OUT	3682	6136	8590
140	IN	4313	7188	10063
	OUT	4618	7697	10776
160	IN	5655	9425	13195
	OUT	6032	10053	14074
180	IN	7257	12095	16933
	OUT	7634	12724	17813
200	IN	9048	15080	21112
	OUT	9425	15708	21991

Weight

Without Auto Switch

Bore size (mm)	Cylinder stroke (mm)												
	10	20	30	40	50	75	100	125	150	175	200	250	300
125	5.24	5.48	5.71	5.94	6.18	6.76	7.35	7.93	8.52	9.10	9.69	10.86	12.03
140	6.19	6.44	6.71	6.98	7.25	7.90	8.57	9.23	9.90	10.56	11.23	12.55	13.88
160	8.57	8.88	9.20	9.52	9.84	10.64	11.44	12.25	13.05	13.85	14.65	16.26	17.85
180	11.54	11.92	12.31	12.70	13.09	14.05	15.03	16.00	16.97	17.93	18.90	20.84	22.78
200	14.56	15.07	15.49	15.92	16.34	17.41	18.47	19.54	20.60	21.67	22.82	24.85	26.99

With Auto Switch

Bore size (mm)	Cylinder stroke (mm)												
	10	20	30	40	50	75	100	125	150	175	200	250	300
125	5.30	5.54	5.77	6.01	6.24	6.83	7.40	7.99	8.58	9.16	9.75	10.92	12.09
140	6.26	6.51	6.78	7.05	7.32	7.97	8.64	9.30	9.97	10.63	11.30	12.62	13.95
160	8.65	8.96	9.28	9.60	9.92	10.72	11.52	12.33	13.13	13.93	14.73	16.34	17.93
180	11.62	12.00	12.39	12.78	13.17	14.13	15.11	16.08	17.05	18.01	18.98	20.92	22.86
200	14.64	15.15	15.57	16.00	16.42	17.49	18.55	19.62	20.68	21.75	22.90	24.93	27.07

Mounting Bolt for CQ2B

Mounting method: Mounting bolt for through-hole mounting of the C(D)Q2B is available as an option. Refer to the following for ordering procedures. Order the actual number of bolts that will be used.

Example) CQ-M12 x 100L 4 pcs.

Note 1) To install a through-hole type mounting bolt, make sure to use the flat washer that is provided.

Note 2) For mounting bolts for the stroke length exceeding 100 mm, use the OA screw provided on the cylinder tube to secure the cylinder.

Material: Chromium molybdenum steel
Surface treatment: Zinc chromated

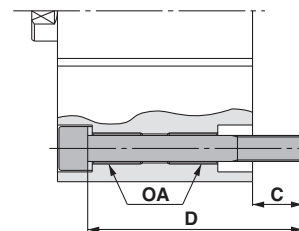

Cylinder model	C	D	Mounting bolt part no.
C□Q2B125/140-10DCZ	22.9	100	CQ-M12 x 100L
-20DCZ		110	x 110L
-30DCZ		120	x 120L
-40DCZ		130	x 130L
-50DCZ		140	x 140L
-75DCZ		165	x 165L
-100DCZ		190	x 190L
C□Q2B160-10DCZ	27.7	110	CQ-M14 x 110L
-20DCZ		120	x 120L
-30DCZ		130	x 130L
-40DCZ		140	x 140L
-50DCZ		150	x 150L
-75DCZ		175	x 175L
-100DCZ		200	x 200L

Cylinder model	C	D	Mounting bolt part no.
C□Q2B180-10DCZ	36	125	CQ-M18 x 125L
-20DCZ		135	x 135L
-30DCZ		145	x 145L
-40DCZ		155	x 155L
-50DCZ		165	x 165L
-75DCZ		190	x 190L
-100DCZ		215	x 215L
C□Q2B200-10DCZ	39	135	CQ-M18 x 135L
-20DCZ		145	x 145L
-30DCZ		155	x 155L
-40DCZ		165	x 165L
-50DCZ		175	x 175L
-75DCZ		200	x 200L
-100DCZ		225	x 225L

Construction

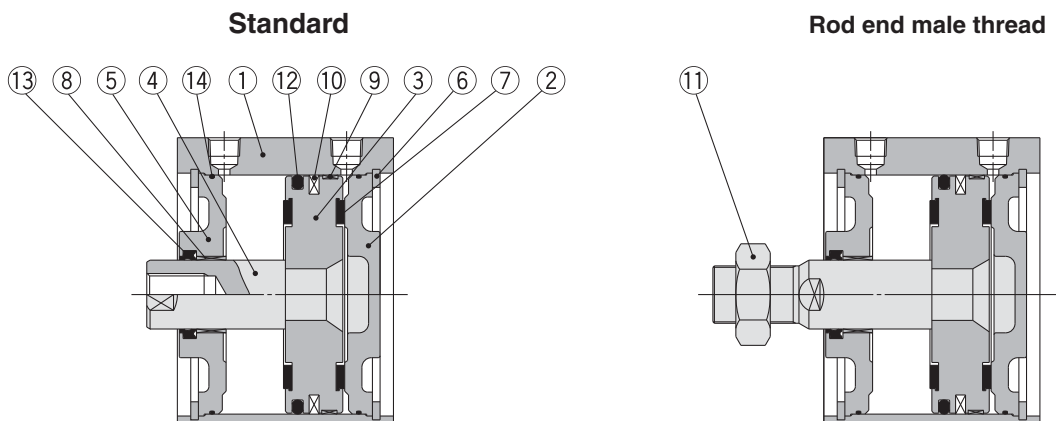

Component Parts

No.	Description	Material	Note
1	Cylinder tube	Aluminum alloy	Hard anodised
2	Head cover	Carbon steel	Nickel plated
3	Piston	Aluminum alloy	Chromated
4	Piston rod	Carbon steel	Hard chrome plated
5	Rod cover	Carbon steel	Nickel plated
6	Retaining ring	Carbon tool steel	Phosphate coated
7	Bumper	Urethane	
8	Bushing	Bearing alloy	
9	Wear ring	Resin	
10	Magnet	—	For CDQ2B□ only
11	Rod end nut	Carbon steel	Nickel plated
12	Piston seal	NBR	
13	Rod seal	NBR	
14	Tube gasket	NBR	

Replacement Parts/Seal Kit

Bore size (mm)	Kit no.	Contents
125	CQ2B125-PS	Kits include items ⑫, ⑬, ⑭ from the table.
140	CQ2B140-PS	
160	CQ2B160-PS	
180	CQ2B180-PS	
200	CQ2B200-PS	

* Seal kit includes ⑫, ⑬, ⑭. Order the seal kit, based on each bore size.

* Since the seal kit does not include a grease pack, order it separately.

Grease pack part no.: GR-S-010 (10 g)

Rod End Nut

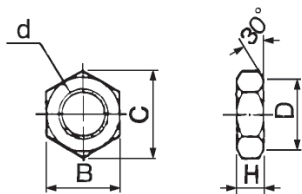

Material: Carbon steel
Surface treatment: Nickel plated

Part no.	Applicable bore size (mm)	d	H	B	C	D
NT-12	125, 140	M30 x 1.5	18	46	53.1	44
NT-16	160, 180, 200	M36 x 1.5	21	55	63.5	53

Retaining Ring Installation/Removal

⚠ Caution

- For installation and removal, use an appropriate pair of pliers (tool for installing a type C retaining ring).
- Even if a proper plier (tool for installing a type C retaining ring) is used, it is likely to inflict damage to a human body or peripheral equipment, as a retaining ring may be flown out of the tip of a plier (tool for installing a type C retaining ring). Be much careful with the popping of a retaining ring. Besides, be certain that a retaining ring is placed firmly into the groove of rod cover before supplying air at the time of installment.

Standard
Large Bore Size
Long Stroke
Non-rotating Rod
Axial Piping
Anti-lateral Load
With End Lock
Water Resistant
With Auto Switch
Auto Switch
Made to Order

Series CQ2

Dimensions

∅125 to ∅160

The dimensions are the same with or without an auto switch.

Standard (Through-hole): C□Q2B

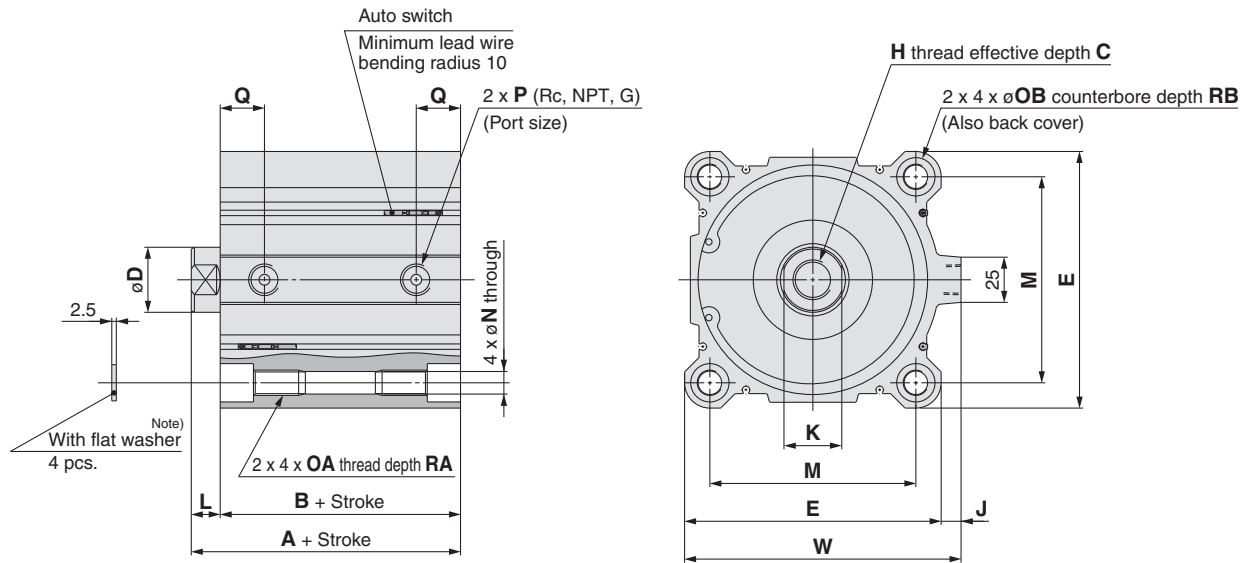

Rod end male thread

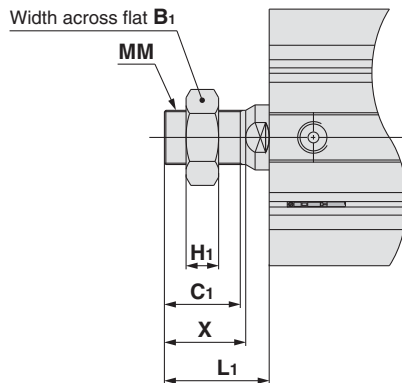

Rod End Male Thread (mm)

Bore size (mm)	B_1	C_1	H_1	L_1	MM	X
125	46	42	18	58	M30 x 1.5	45
140	46	42	18	58	M30 x 1.5	45
160	55	47	21	64	M36 x 1.5	50

Bore size (mm)	Standard stroke	A	B	C	D	E	H	J	K	L	M	N	OA	OB	P	Q	RA	RB	W
125	10, 20, 30, 40, 50	99	83	30	36	142	M22 x 2.5	11	32	16	114	12.5	M14 x 2	21.2	3/8	24.5	25	18.4	153
140	75, 100, 125, 150	99	83	30	36	158	M22 x 2.5	10	32	16	128	12.5	M14 x 2	21.2	3/8	24.5	25	18.4	168
160	175, 200, 250, 300	108	91	33	40	178	M24 x 3	10	36	17	144	14.5	M16 x 2	24.2	3/8	27.5	28	21.2	188

Note) Be sure to use the attached flat washer for mounting cylinder with through-holes.

Dimensions

∅180, ∅200

∅180

The dimensions are the same with or without an auto switch.

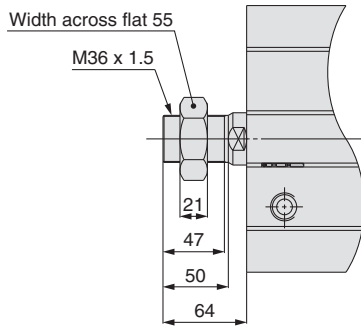
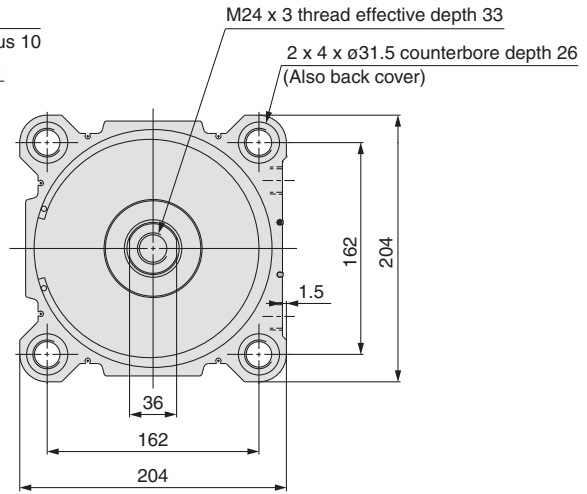
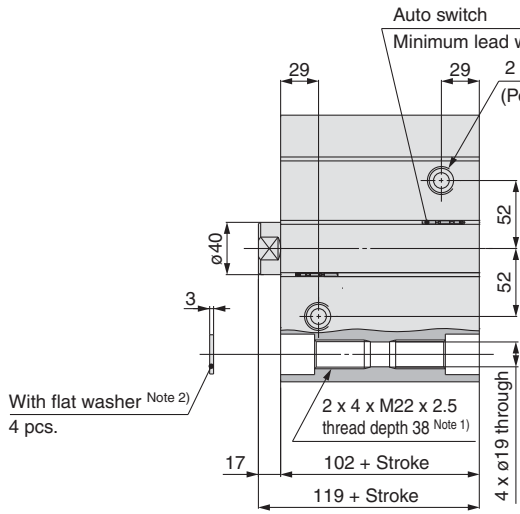

Note 1) In the case of 20 mm stroke or less, it would come with 2 x 4 x M22 x 2.5 through thread.

Note 2) Be sure to use the attached flat washer for mounting cylinder with through-holes.

∅200

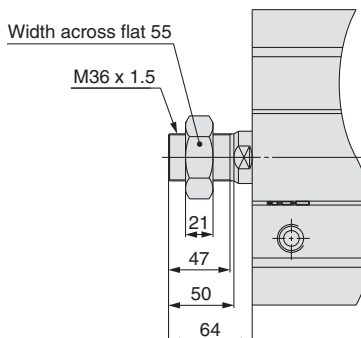
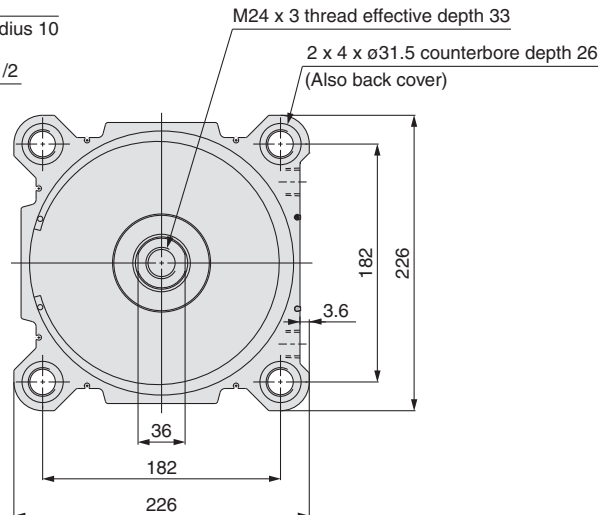
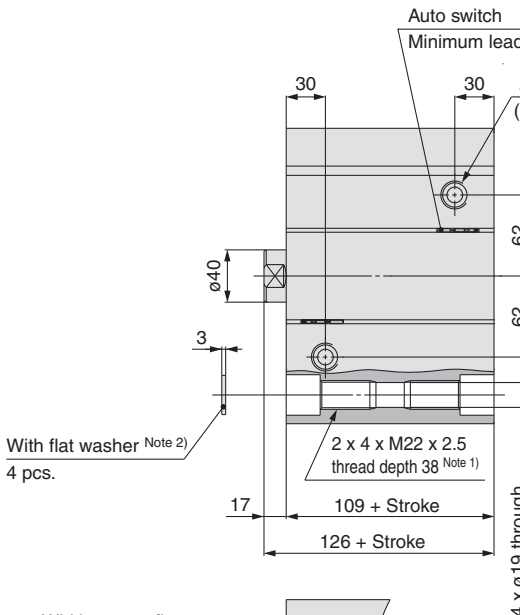

Note 1) In the case of 20 mm stroke or less, it would come with 2 x 4 x M22 x 2.5 through thread.

Note 2) Be sure to use the attached flat washer for mounting cylinder with through-holes.

Standard

Large Bore Size

Long Stroke

Non-rotating Rod

Axial Piping

Anti-lateral Load

With End Lock

Water Resistant

With Auto Switch

Auto Switch

Made to Order

Compact Cylinder: Large Bore Size Double Acting, Double Rod Series CQ2W

ø125, ø140, ø160, ø180, ø200

How to Order

Without auto switch

CQ2WB 125 [] - 30 DC [] Z - []

With auto switch

CDQ2WB 125 [] - 30 DC [] Z - M9BW [] - []

With auto switch
(Built-in magnet)

Type
W Double rod

Mounting

B Through-hole/Both ends tapped common (Standard)

* Cylinder mounting bolts are not included. Order them separately referring to "Mounting Bolt for CQ2WB" on page 80.

Bore size

125	125 mm
140	140 mm
160	160 mm
180	180 mm
200	200 mm

Port thread type

-	Rc
TN	NPT
TF	G

Built-in Magnet Cylinder Model

If a built-in magnet cylinder without an auto switch is required, there is no need to enter the symbol for the auto switch.

(Example) CDQ2WB140-30DCZ

Cylinder stroke (mm)

Refer to the next page for standard strokes.

Made to Order
Refer to the next page for details.

Number of auto switches

-	2 pcs.
S	1 pc.
n	"n" pcs.

Auto switch

- Without auto switch

* Refer to the below table for applicable auto switches.

Auto switch mounting groove

Z ø125 to ø200 4 surfaces

Body option

-	Standard (Rod end female thread)
M	Rod end male thread

Cushion

C Rubber bumper

Action

D Double acting

Applicable Auto Switches/Refer to pages 1263 to 1371 in Best Pneumatics No. 2 for further information on auto switches.

Type	Special function	Electrical entry	Indicator light	Wiring (Output)	Load voltage		Auto switch model		Lead wire length (m)					Pre-wired connector	Applicable load													
					DC	AC	Perpendicular	In-line	0.5 (-)	1 (M)	3 (L)	5 (Z)	None (N)		IC circuit	Relay, PLC												
Solid state auto switch	—	Grommet	Yes	3-wire (NPN)	24 V	5 V, 12 V	—	M9NV	M9N	●	●	●	○	—	○	IC circuit	Relay, PLC											
				3-wire (PNP)				M9PV	M9P	●	●	●	○	—	○													
				2-wire				M9BV	M9B	●	●	●	○	—	○													
	Diagnostic indication (2-colour indication)			3-wire (NPN)				24 V	5 V, 12 V	—	M9NV	M9N	●	●	●			○	—	○	IC circuit	Relay, PLC						
				3-wire (PNP)							M9PV	M9P	●	●	●			○	—	○								
				2-wire							M9BV	M9B	●	●	●			○	—	○								
	Water resistant (2-colour indication)			3-wire (NPN)							24 V	5 V, 12 V	—	M9NAV**	M9NA**			○	○	●			○	—	○	IC circuit	Relay, PLC	
				3-wire (PNP)										M9PAV**	M9PA**			○	○	●			○	—	○			
				2-wire										M9BAV**	M9BA**			○	○	●			○	—	○			
Reed auto switch	—	Grommet	Yes	3-wire (NPN equivalent)	24 V	5 V, 12 V	100 V or less							A96V	A96	●	—	●	—	—			IC circuit	—				
				2-wire										A93V	A93	●	—	●	—	—					—			Relay, PLC
				—										A90V	A90	●	—	●	—	—								

** Water resistant type auto switches can be mounted on the above models, but in such case SMC cannot guarantee water resistance. Consult with SMC regarding water resistant types with the above model numbers.

* Lead wire length symbols: 0.5 m — (Example) M9NW
1 m M (Example) M9NWM
3 m L (Example) M9NWL
5 m Z (Example) M9NWZ

* Solid state auto switches marked with "○" are produced upon receipt of order.

* There are other applicable auto switches other than the listed above. For details, refer to page 199.

* For details about auto switches with pre-wired connector, refer to pages 1328 and 1329 in Best Pneumatics No. 2.

Compact Cylinder: Large Bore Size Double Acting, Double Rod **Series CQ2W**

Specifications

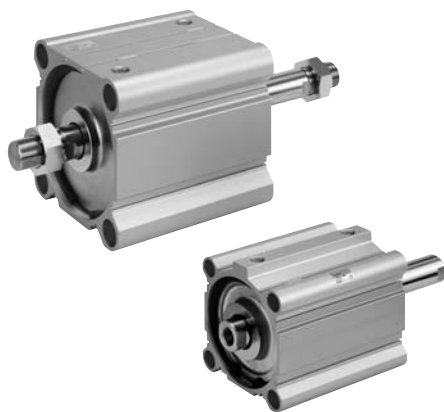

Symbol

Double acting,
Double rod

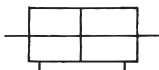

Made to Order

(For details, refer to pages 201 to 235.)

Symbol	Specifications
-XA□	Change of rod end shape
-XB10	Intermediate stroke (Exclusive body type)
-XC85	Grease for food processing equipment
-X235	Special rod end for double rod cylinder
-X271	Fluororubber seals, ø125 to ø160 only
-X633	Intermediate stroke of double rod cylinder

* -X633: Intermediate stroke in 5 mm intervals only

Bore size (mm)	125	140	160	180	200
Action	Double acting, Double rod				
Fluid	Air				
Proof pressure	1.5 MPa			1.05 MPa	
Maximum operating pressure	1.0 MPa			0.7 MPa	
Minimum operating pressure	0.05 MPa				
Ambient and fluid temperature	Without auto switch: -10 to 70°C (No freezing) With auto switch: -10 to 60°C (No freezing)				
Lubrication	Not required (Non-lube)				
Piston speed	50 to 500 mm/s			20 to 400 mm/s	
Allowable kinetic energy (J)	7.4	9.8	12.4		
Stroke length tolerance	+1.4 mm (Note) 0				

Note) Stroke length tolerance does not include the amount of bumper change.

Standard Strokes

Bore size (mm)	Standard stroke (mm)
125, 140, 160 180, 200	10, 20, 30, 40, 50, 75, 100, 125, 150, 175, 200, 250, 300

Manufacture of Intermediate Strokes

Type	A spacer is installed in the standard stroke body.	Exclusive body (-XB10)
Part no.	Suffix "-X633" to the end of standard model number. (P. 77)	Suffix "-XB10" to the end of standard model number. (P. 77)
Description	Strokes in 5 mm intervals are available by installing a spacer in the standard stroke cylinder.	Strokes in 1 mm intervals are available by using an exclusive body with the specified stroke.
Stroke range	Bore size 125 to 200	Bore size 125 to 200
	Stroke range 5 to 295	Stroke range 11 to 299
Example	Part no.: CQ2WB160-165DCZ-X633 CQ2WB160-175DCZ with 10 mm width spacer inside The B dimension is 266 mm.	Part no.: CQ2WB160-165DCZ-XB10 Makes 165 mm stroke tube. The B dimension is 256 mm.

Refer to pages 193 to 199 for the specifications of cylinders with autoswitches.

- Auto switch proper mounting position (detection at stroke end) and its mounting height
- Minimum stroke for auto switch mounting
- Operating range
- Auto switch mounting brackets/Part no.

Standard

Large Bore Size

Long Stroke

Non-rotating Rod

Axial Piping

Anti-lateral Load

With End Lock

Water Resistant

With Auto Switch

Auto Switch

Made to Order

Series CQ2W

Retaining Ring Installation/Removal

⚠ Caution

1. For installation and removal, use an appropriate pair of pliers (tool for installing a type C retaining ring).
2. Even if a proper plier (tool for installing a type C retaining ring) is used, it is likely to inflict damage to a human body or peripheral equipment, as a retaining ring may be flown out of the tip of a plier (tool for installing a type C retaining ring). Be much careful with the popping of a retaining ring. Besides, be certain that a retaining ring is placed firmly into the groove of rod cover before supplying air at the time of installment.

Mounting

⚠ Warning

Do not apply reverse torque to the piston rods sticking out from both sides of this cylinder at the same time. The torque makes connection threads inside loosen, which may cause an accident or malfunction. Install or remove loads while the piston rod width across flat is secured. Do not fix the other side of the piston rod width across flat and apply reverse torque.

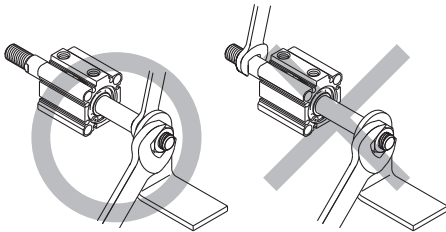

Theoretical Output

Bore size (mm)	Operating pressure (MPa)		
	0.3	0.5	0.7
125	3376	5627	7878
140	4313	7188	10063
160	5655	9425	13195
180	7257	12095	16933
200	9048	15080	21112

(N)

Weight

Without Auto Switch

(kg)

Bore size (mm)	Cylinder stroke (mm)												
	10	20	30	40	50	75	100	125	150	175	200	250	300
125	5.47	5.76	6.05	6.37	6.68	7.47	8.24	9.03	9.82	10.60	11.39	12.96	14.52
140	6.43	6.73	7.06	7.40	7.75	8.61	9.47	10.33	11.20	12.06	12.92	14.64	16.37
160	8.87	9.26	9.65	10.07	10.49	11.53	12.58	13.63	14.68	15.72	16.77	18.87	20.96
180	11.75	12.23	12.73	13.21	13.70	14.91	16.13	17.34	18.56	19.77	20.99	23.42	25.86
200	14.89	15.42	15.94	16.47	16.98	18.30	19.61	20.92	21.23	23.54	24.85	27.47	30.10

With Auto Switch

(kg)

Bore size (mm)	Cylinder stroke (mm)												
	10	20	30	40	50	75	100	125	150	175	200	250	300
125	5.53	5.82	6.11	6.43	6.74	7.53	8.30	9.09	9.88	10.66	11.45	13.02	14.58
140	6.50	6.80	7.13	7.47	7.82	8.68	9.54	10.40	11.27	12.13	12.99	14.71	16.44
160	8.95	9.34	9.73	10.15	10.57	11.61	12.66	13.71	14.76	15.80	16.85	18.95	21.04
180	11.83	12.31	12.81	13.29	13.78	14.99	16.21	17.42	18.64	19.85	21.07	23.50	25.94
200	14.97	15.50	16.02	16.55	17.06	18.38	19.69	21.00	21.31	23.62	24.93	27.55	30.18

Additional Weight

(kg)

Bore size (mm)		125	140	160, 180, 200
Rod end male thread	Male thread	0.62	0.62	0.96
	Nut	0.32	0.32	0.52

Calculation: (Example) **CDQ2WB125-30DCMZ**

• Basic weight: CDQ2WB125-30DCZ6.11 kg

• Additional weight: Rod end male thread0.94 kg

7.05 kg

Mounting Bolt for CQ2WB

Mounting method: Mounting bolt for through-hole mounting of the C(D)Q2WB is available as an option. Refer to the following for ordering procedures. Order the actual number of bolts that will be used.

Example) CQ-M12 x 100L 4 pcs.

Note 1) To install a through-hole type mounting bolt, make sure to use the flat washer that is provided.

Note 2) For mounting bolts for the stroke length exceeding 100 mm, use the OA screw provided on the cylinder tube to secure the cylinder.

Material: Chromium molybdenum steel
Surface treatment: Zinc chromated

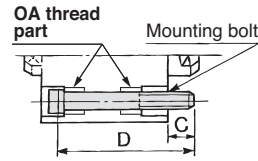

Cylinder model	C	D	Mounting bolt part no.
C□Q2WB125/140-10DCZ	22.9	100	CQ-M12 x 100L
-20DCZ		110	x 110L
-30DCZ		120	x 120L
-40DCZ		130	x 130L
-50DCZ		140	x 140L
-75DCZ		165	x 165L
-100DCZ		190	x 190L
C□Q2WB160-10DCZ	27.7	110	CQ-M14 x 110L
-20DCZ		120	x 120L
-30DCZ		130	x 130L
-40DCZ		140	x 140L
-50DCZ		150	x 150L
-75DCZ		175	x 175L
-100DCZ		200	x 200L

Cylinder model	C	D	Mounting bolt part no.
C□Q2WB180-10DCZ	36	125	CQ-M18 x 125L
-20DCZ		135	x 135L
-30DCZ		145	x 145L
-40DCZ		155	x 155L
-50DCZ		165	x 165L
-75DCZ		190	x 190L
-100DCZ		215	x 215L
C□Q2WB200-10DCZ	39	135	CQ-M18 x 135L
-20DCZ		145	x 145L
-30DCZ		155	x 155L
-40DCZ		165	x 165L
-50DCZ		175	x 175L
-75DCZ		200	x 200L
-100DCZ		225	x 225L

Construction

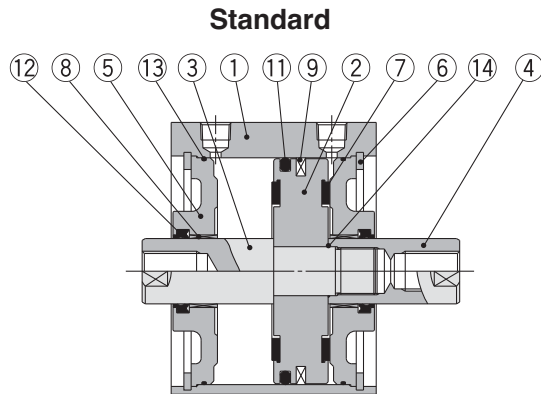

Standard

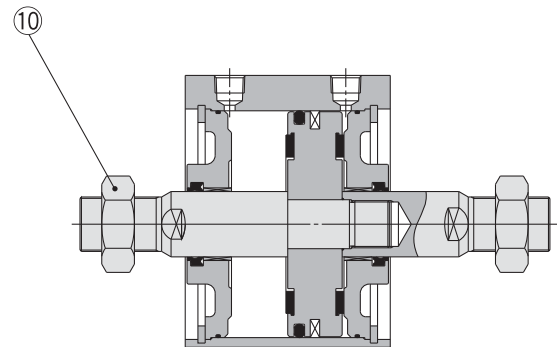

Rod end male thread

Component Parts

No.	Description	Material	Note
1	Cylinder tube	Aluminum alloy	Hard anodised
2	Piston	Aluminum alloy	Chromated
3	Piston rod A	Carbon steel	Hard chrome plated
4	Piston rod B	Carbon steel	Hard chrome plated
5	Rod cover	Carbon steel	Nickel plated
6	Retaining ring	Carbon tool steel	Phosphate coated
7	Bumper	Resin	
8	Bushing	Bearing alloy	
9	Magnet	—	For CDQ2WB□ only
10	Rod end nut	Carbon steel	Nickel plated
11	Piston seal	NBR	
12	Rod seal	NBR	
13	Tube gasket	NBR	
14	Piston gasket	NBR	

Replacement Parts/Seal Kit

Bore size (mm)	Kit no.	Contents
125	CQ2WB125-PS	Kits include items ⑪, ⑫, ⑬ from the table.
140	CQ2WB140-PS	
160	CQ2WB160-PS	
180	CQ2WB180-PS	
200	CQ2WB200-PS	

* Seal kit includes ⑪, ⑫, ⑬. Order the seal kit, based on each bore size.

* Since the seal kit does not include a grease pack, order it separately.

Grease pack part no.: GR-S-010 (10 g)

Rod End Nut

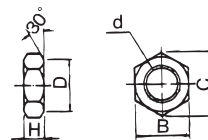

Material: Carbon steel
Surface treatment: Nickel plated

Part no.	Applicable bore size (mm)	d	H	B	C	D
NT-12	125, 140	M30 x 1.5	18	46	53.1	44
NT-16	160, 180, 200	M36 x 1.5	21	55	63.5	53

Series CQ2W

Dimensions

∅125 to ∅160

The dimensions are the same with or without an auto switch.

Standard (Through-hole): C□Q2WB

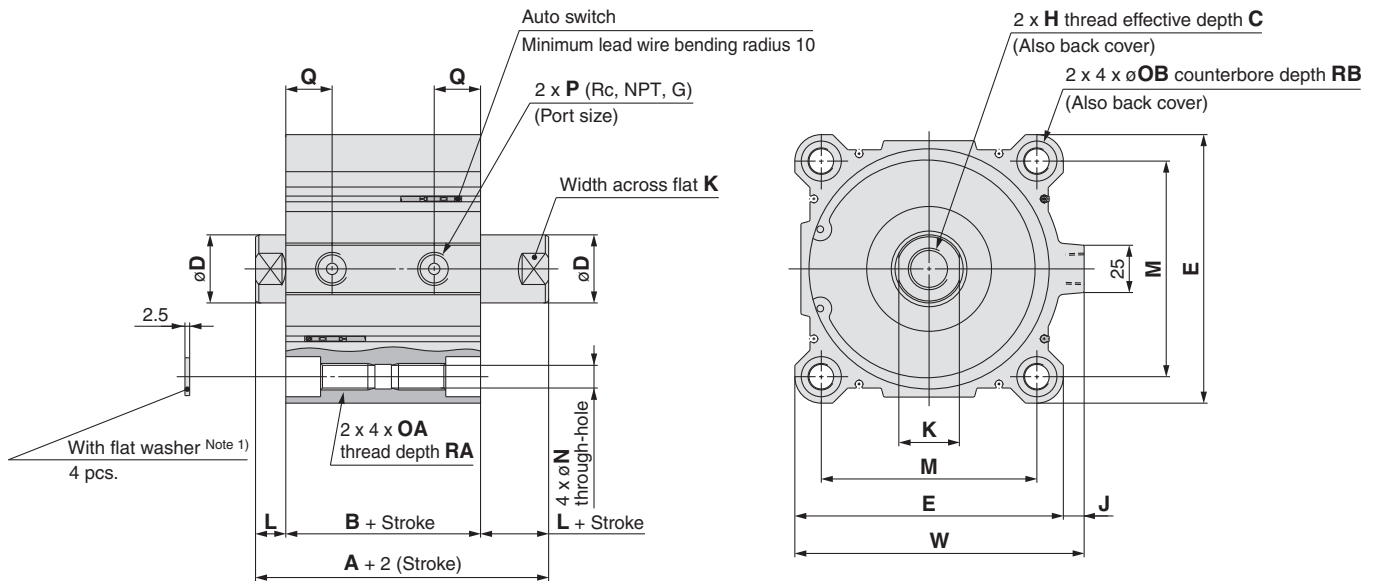

Rod end male thread

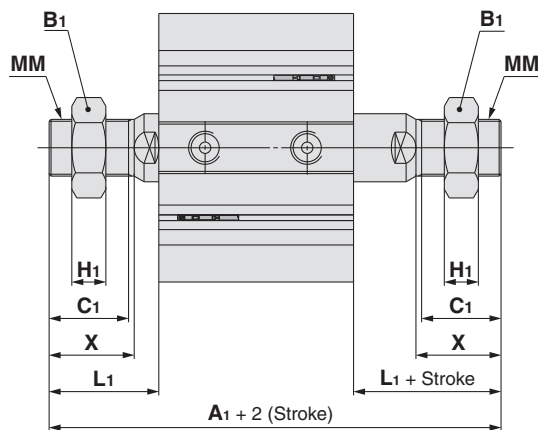

Rod End Male Thread

Bore size (mm)	A ₁	B ₁	C ₁	H ₁	L ₁	MM	X
125	199	46	42	18	58	M30 x 1.5	45
140	199	46	42	18	58	M30 x 1.5	45
160	219	55	47	21	64	M36 x 1.5	50

Bore size (mm)	Standard stroke	A	B	C ^{Note 2)}	D	E	H	J	K	L	M	N	OA	OB	P	Q	RA	RB	W
125	10, 20, 30, 40, 50	115	83	30 (22.5)	36	142	M22 x 2.5	11	32	16	114	12.5	M14 x 2	21.2	3/8	24.5	25	18.4	153
	75, 100, 125, 150	115	83	30 (22.5)	36	158	M22 x 2.5	10	32	16	128	12.5	M14 x 2	21.2	3/8	24.5	25	18.4	168
160	175, 200, 250, 300	125	91	33 (26.5)	40	178	M24 x 3	10	36	17	144	14.5	M16 x 2	24.2	3/8	27.5	28	21.2	188

Note 1) Be sure to use the attached flat washer for mounting cylinder with through-holes.

Note 2) (): Values of effective length in one side, only for 10 mm stroke model

* The positions of double rod width across flats are not the same.

Compact Cylinder: Long Stroke Double Acting, Single Rod Series CQ2

ø32, ø40, ø50, ø63, ø80, ø100

How to Order

Without auto switch

CQ2 A 32 [] - 200 DC [] Z - []

With auto switch

CDQ2 A 32 [] - 200 DC [] Z - M9BW [] - []

With auto switch
(Built-in magnet)

Mounting

A	Both ends tapped
L	Foot
LC	Compact foot
F	Rod flange
G	Head flange
D	Double clevis

* Mounting brackets are shipped together, (but not assembled).

Bore size

32	32 mm
40	40 mm
50	50 mm
63	63 mm
80	80 mm
100	100 mm

Port thread type

—	Rc
TN	NPT
TF	G
F	Built-in one-touch fittings <small>Note)</small>

Note) Bore sizes available with one-touch fittings are ø32 to ø63.

Cylinder stroke (mm)

Refer to the next page for standard strokes.

Action

D Double acting

Cushion

C Rubber bumper

Number of auto switches

—	2 pcs.
S	1 pc.
n	"n" pcs.

Made to Order

Refer to the next page for details.

Auto switch

— Without auto switch

* Refer to the below table for applicable auto switches.

Auto switch mounting groove

Z 4 surfaces

Body option

—	Standard (Rod end female thread)
M	Rod end male thread

Built-in Magnet Cylinder Model

If a built-in magnet cylinder without an auto switch is required, there is no need to enter the symbol for the auto switch.
(Example) CDQ2L40-200DCZ

Applicable Auto Switches

Refer to pages 1263 to 1371 in Best Pneumatics No. 2 for further information on auto switches.

Refer to the individual catalogue (ES20-201) for the D-P3DW type.

Type	Special function	Electrical entry	Indicator light	Wiring (Output)	Load voltage		Auto switch model		Lead wire length (m)					Pre-wired connector	Applicable load			
					DC	AC	Perpendicular	In-line	0.5 (—)	1 (M)	3 (L)	5 (Z)	None (N)		IC circuit	Relay, PLC		
Solid state auto switch	—	Grommet	Yes	3-wire (NPN)	24 V	5 V, 12 V	—	M9NV	M9N	●	●	●	○	—			○	IC circuit
				3-wire (PNP)				M9PV	M9P	●	●	●	○	—	○			
				2-wire				M9BV	M9B	●	●	●	○	—	○			
				3-wire (NPN)				M9NVV	M9NV	●	●	●	○	—	○			
	Diagnostic indication (2-colour indication)			3-wire (PNP)				M9PWV	M9PW	●	●	●	○	—	○	IC circuit		
				2-wire				M9BVV	M9BV	●	●	●	○	—	○			
	Water resistant (2-colour indication)			3-wire (NPN)				M9NAV**	M9NA**	○	○	●	○	—	○	IC circuit		
				3-wire (PNP)				M9PAV**	M9PA**	○	○	●	○	—	○			
	Magnetic field resistant (2-colour indication)	—	Grommet	No	2-wire	24 V	5 V, 12 V	100 V or less	M9BAV**	M9BA**	○	○	●	○	—	○	IC circuit	
					2-wire (Non-polar)				—	P3DW	●	—	●	—	○			
3-wire (NPN equivalent)					A96V				A96	●	—	●	—	—	—			
2-wire					A93V				A93	●	—	●	—	—	—			
Reed auto switch	—	Grommet	Yes	3-wire (NPN equivalent)	24 V	5 V	100 V or less	A90V	A90	●	—	●	—	—	IC circuit			
				2-wire				—	—	●	—	●	—	—				

* Water resistant type auto switches can be mounted on the above models, but in such case SMC cannot guarantee water resistance. Consult with SMC regarding water resistant types with the above model numbers.

* Lead wire length symbols: 0.5 m — (Example) M9NW
1 m M (Example) M9NWM
3 m L (Example) M9NWL
5 m Z (Example) M9NWZ

* Solid state auto switches marked with "O" are produced upon receipt of order.

* There are other applicable auto switches other than the listed above. For details, refer to page 199.

* For details about auto switches with pre-wired connector, refer to pages 1328 and 1329 in Best Pneumatics No. 2.

Compact Cylinder: Long Stroke Double Acting, Single Rod *Series CQ2*

Specifications



Symbol

Double acting,
Single rod

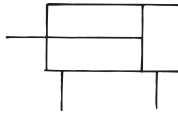

Bore size (mm)	32	40	50	63	80	100
Action	Double acting, Single rod					
Fluid	Air					
Proof pressure	1.5 MPa					
Maximum operating pressure	1.0 MPa					
Minimum operating pressure	0.05 MPa					
Ambient and fluid temperature	Without auto switch: -10 to 70°C (No freezing) With auto switch: -10 to 60°C (No freezing)					
Lubrication	Not required (Non-lube)					
Piston speed	50 to 500 mm/s					
Allowable kinetic energy (J)	0.29	0.52	0.91	1.54	2.71	4.54
Stroke length tolerance	+1.4 mm Note) 0					

Note) Stroke length tolerance does not include the amount of bumper change.

Standard Strokes

Bore size	Standard stroke (mm)
32, 40, 50 63, 80, 100	125, 150, 175, 200, 250, 300

Manufacture of Intermediate Strokes

Type	A spacer is installed in the standard stroke body.	Exclusive body (-XB10)	
Part no.	Refer to "How to Order" for the standard model number. (P. 83)	Suffix "-XB10" to the end of standard model number. (P. 83)	
Description	Strokes in 1 mm intervals are available by installing a spacer in the standard stroke cylinder.	Strokes in 1 mm intervals are available by using an exclusive body with the specified stroke.	
Stroke range	Bore size	Bore size	Stroke range
	32 to 100	101 to 299	32 to 100 101 to 299
Example	Part no.: CQ2A50-166DCZ CQ2B50-175DCZ with 9 mm width spacer inside The B dimension is 230.5 mm.	Part no.: CQ2B50-166DCZ-XB10 Makes 166 mm stroke tube. The B dimension is 221.5 mm.	

Type

Bore size (mm)		32	40	50	63	80	100		
Pneumatic	Built-in magnet	●	●	●	●	●	●		
	Piping	Pipe thread	—	Rc1/8	Rc1/8	Rc1/4	Rc1/4	Rc3/8	Rc3/8
			TN	NPT1/8	NPT1/8	NPT1/4	NPT1/4	NPT3/8	NPT3/8
		TF	G1/8	G1/8	G1/4	G1/4	G3/8	G3/8	
	Built-in one-touch fittings ^{Note)}	ø6/4	ø6/4	ø8/6	ø8/6	—	—		
	Rod end male thread	●	●	●	●	●	●		

Note) One-touch fittings cannot be replaced.

Refer to pages 193 to 199 for the specifications of cylinders with autoswitches.

- Auto switch proper mounting position (detection at stroke end) and its mounting height
- Minimum stroke for auto switch mounting
- Operating range
- Auto switch mounting brackets/Part no.



Made to Order

(For details, refer to pages 201 to 235.)

Symbol	Specifications
-XA□	Change of rod end shape
-XB10	Intermediate stroke (Exclusive body type)
-XC4	With heavy-duty scraper
-XC6	Piston rod/Retaining ring/Rod end nut material: Stainless steel
-XC26	With split pins for double clevis pin/ double knuckle joint pin and flat washers
-XC85	Grease for food processing equipment
-X271	Fluororubber seals

Standard

Large Bore Size

Long Stroke

Non-rotating Rod

Axial Piping

Anti-lateral Load

With End Lock

Water Resistant

With Auto Switch

Auto Switch

Made to Order

Series CQ2

Copper and Fluorine-free Series (For CRT Manufacturing Process)

20 - C□Q2A Bore size - Stroke DC(M)Z

• $\phi 32, \phi 40, \phi 50, \phi 63$
 $\phi 80, \phi 100$

• Copper and fluorine-free series

For preventing the influence of copper ions or halogen ions during CRT manufacturing processes, copper and fluorine materials are not used in the component parts.

Specifications

Bore size (mm)	32	40	50	63	80	100
Action	Double acting, Single rod					
Proof pressure	1.5 MPa					
Max. operating pressure	1.0 MPa					
Rubber bumper	With (Standard)					
Piping	Pipe thread, Built-in one-touch fittings					
Piston speed	50 to 500 mm/s					
Mounting	Both ends tapped					
Auto switch	Mountable					

Allowable Lateral Load at Rod End

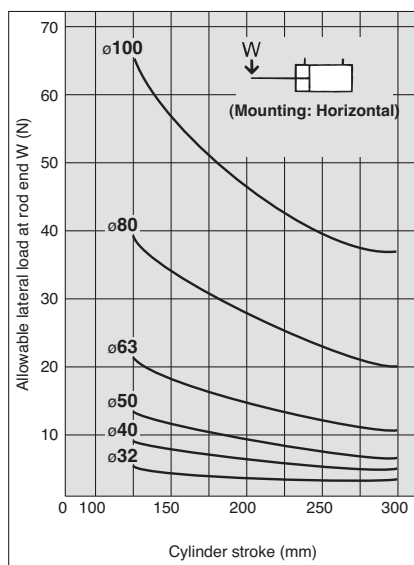

Mounting Brackets/ Part No.

Bore size (mm)	Foot ^{Note 1)}	Compact Foot ^{Note 1)}	Flange	Double clevis
32	CQ-L032	CQ-LC032	CQ-F032	CQ-D032
40	CQ-L040	CQ-LC040	CQ-F040	CQ-D040
50	CQ-L050	CQ-LC050	CQ-F050	CQ-D050
63	CQ-L063	CQ-LC063	CQ-F063	CQ-D063
80	CQ-L080	CQ-LC080	CQ-F080	CQ-D080
100	CQ-L100	CQ-LC100	CQ-F100	CQ-D100

Note 1) When ordering a foot and compact foot brackets, order 2 pieces per cylinder.

Note 2) Parts belonging to each bracket are as follows.

Foot, Compact foot, Flange: Body mounting bolts
Double clevis: Clevis pin, Body mounting bolts, Type C retaining rings for axis.

Theoretical Output

Bore size (mm)	Operating direction	Operating pressure (MPa)		
		0.3	0.5	0.7
32	IN	181	302	422
	OUT	241	402	563
40	IN	317	528	739
	OUT	377	628	880
50	IN	495	825	1155
	OUT	589	982	1374



Bore size (mm)	Operating direction	Operating pressure (MPa)		
		0.3	0.5	0.7
63	IN	841	1402	1962
	OUT	935	1559	2182
80	IN	1361	2268	3175
	OUT	1508	2513	3519
100	IN	2144	3574	5003
	OUT	2356	3927	5498

Weight

Without Auto Switch

Bore size (mm)	Cylinder stroke (mm)					
	125	150	175	200	250	300
32	708	817	918	1017	1215	1415
40	888	997	1107	1217	1438	1657
50	1352	1517	1682	1841	2177	2507
63	1706	1900	2095	2292	2676	3065
80	2832	3130	3429	3725	4324	4921
100	4540	4906	5270	5634	6367	7096

With Auto Switch

Bore size (mm)	Cylinder stroke (mm)					
	125	150	175	200	250	300
32	726	826	927	1026	1224	1424
40	902	1012	1121	1231	1451	1671
50	1367	1532	1697	1856	2192	2522
63	1730	1924	2119	2316	2700	3089
80	2856	3154	3453	3749	4348	4945
100	4578	4944	5308	5672	6405	7134

Additional Weight

Bore size (mm)		32	40	50	63	80	100
Rod end male thread	Male thread	26	27	53	53	120	175
	Nut	17	17	32	32	49	116
Foot (Including mounting bolts)		146	158	253	349	672	1113
Compact Foot (Including mounting bolts)		99	114	177	241	501	770
Rod flange (Including mounting bolts)		165	198	348	534	1017	1309
Head flange (Including mounting bolts)		165	198	348	534	1017	1309
Double clevis (Including pin, retaining rings, bolts)		151	196	393	554	1109	1887

Calculation: (Example) **CQ2D32-200DCMZ**

• Basic weight: CQ2A32-200DCZ 1017 g
 • Additional weight: Rod end male thread 43 g
 Double clevis 151 g
 1211 g

Add each weight of auto switches when auto switches are mounted.

Construction

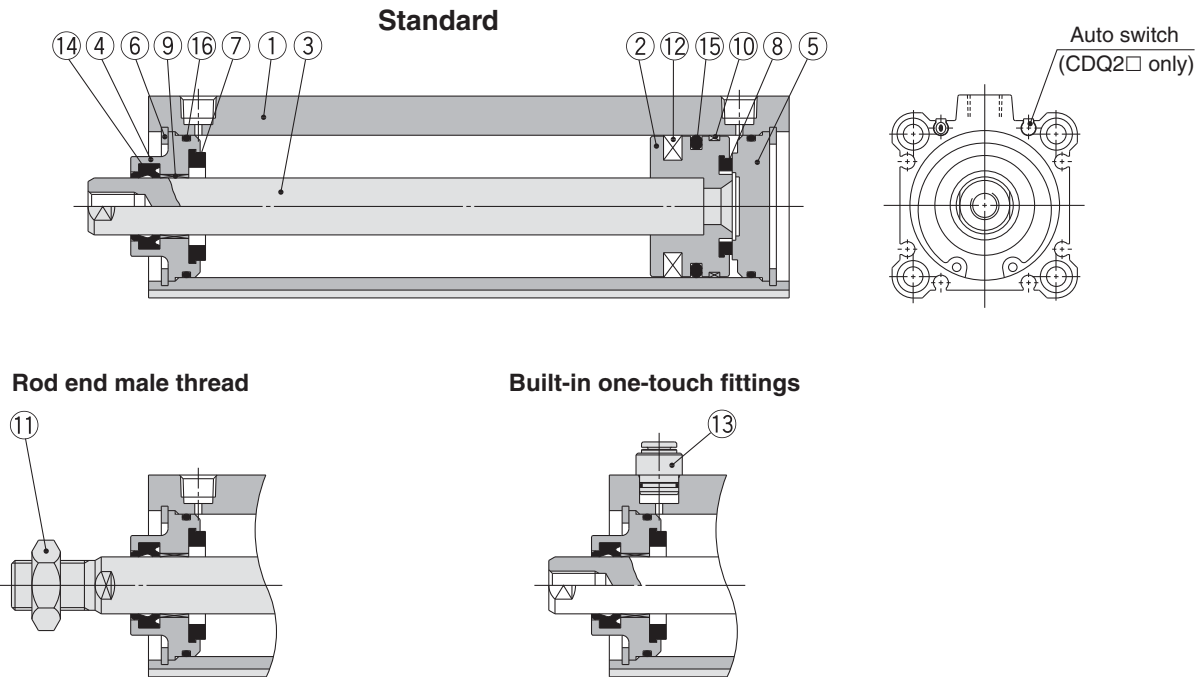

Component Parts

No.	Description	Material	Note
1	Cylinder tube	Aluminum alloy	Hard anodised
2	Piston	Aluminum alloy	Chromated
3	Piston rod	Carbon steel	Hard chrome plated
4	Collar	Aluminum alloy	Anodised
5	Bottom plate	Aluminum alloy	Anodised
6	Retaining ring	Carbon tool steel	Phosphate coated
7	Bumper A	Urethane	
8	Bumper B	Urethane	
9	Bushing	Bearing alloy	
10	Wear ring	Resin	
11	Rod end nut	Carbon steel	Nickel plated
12	Magnet	—	For CDQ2A□ only
13	One-touch fitting	—	ø32 to ø63
14*	Rod seal	NBR	
15*	Piston seal	NBR	
16*	Tube gasket	NBR	

Replacement Parts/Seal Kit

Bore size (mm)	Kit no.	Contents
32	CQ2A32-L-PS	Kits include items 14, 15, 16 from the table.
40	CQ2A40-L-PS	
50	CQ2A50-L-PS	
63	CQ2A63-L-PS	
80	CQ2A80-L-PS	
100	CQ2A100-L-PS	

* Seal kit includes 14, 15, 16. Order the seal kit, based on each bore size.
* Since the seal kit does not include a grease pack, order it separately.
Grease pack part no.: GR-S-010 (10 g)

Retaining Ring Installation/Removal

⚠ Caution

- For installation and removal, use an appropriate pair of pliers (tool for installing a type C retaining ring).
- Even if a proper plier (tool for installing a type C retaining ring) is used, it is likely to inflict damage to a human body or peripheral equipment, as a retaining ring may be flown out of the tip of a plier (tool for installing a type C retaining ring). Be much careful with the popping of a retaining ring. Besides, be certain that a retaining ring is placed firmly into the groove of rod cover before supplying air at the time of installment.

Standard

Large Bore Size

Long Stroke

Non-rotating Rod

Axial Piping

Anti-lateral Load

With End Lock

Water Resistant

With Auto Switch

Auto Switch

Made to Order

Series CQ2

Dimensions

∅32 to ∅50

The dimensions are the same with or without an auto switch.

Both ends tapped: C□Q2A

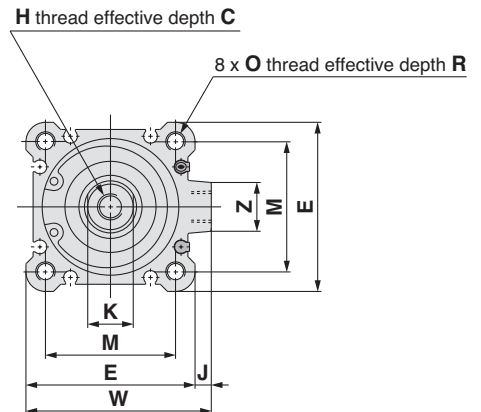
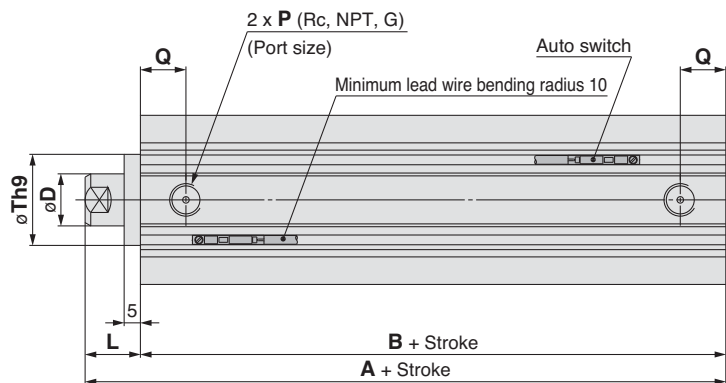

Rod end male thread

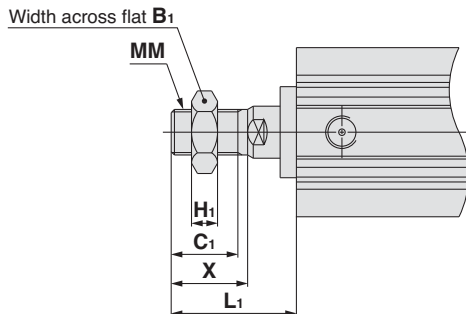

Rod End Male Thread (mm)

Bore size (mm)	B ₁	C ₁	H ₁	L ₁	MM	X
32	22	20.5	8	38.5	M14 x 1.5	23.5
40	22	20.5	8	38.5	M14 x 1.5	23.5
50	27	26	11	43.5	M18 x 1.5	28.5

The dimensions with built-in one-touch fittings are equivalent to those of the CQ2 series, double acting, single rod. Refer to page 17.

Both Ends Tapped

For auto switch proper mounting position and its mounting height, refer to pages 193 to 199.

Bore size (mm)	Stroke range (mm)	A	B	C	D	E	H	J	K	L	M	O	P	Q	R	Th9	W	Z
32	125 to 200 250, 300	62.5	45.5	13	16	45	M8 x 1.25	4.5	14	17	34	M6 x 1.0	1/8	10	10	22 ⁰ _{-0.052}	49.5	14
40		72	55	13	16	52	M8 x 1.25	5	14	17	40	M6 x 1.0	1/8	12.5	10	28 ⁰ _{-0.052}	57	15
50		73.5	55.5	15	20	64	M10 x 1.5	7	17	18	50	M8 x 1.25	1/4	14	14	35 ⁰ _{-0.062}	71	19

Note 1) For 125 to 200 strokes, strokes are available in 25 mm intervals.

Note 2) For calculation on the longitudinal dimension of intermediate strokes, refer to page 84.

Foot: C□Q2L

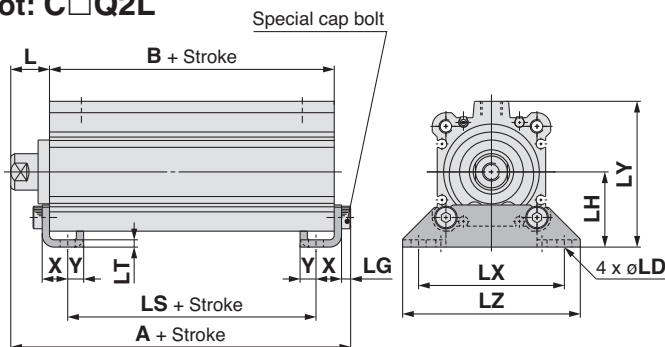

Foot (mm)

Bore size (mm)	A	B	L	L ₁	LD	LG	LH	LS	LT	LX	LY	LZ	X	Y
32	69.7	45.5	17	38.5	6.6	4	30	29.5	3.2	57	57	71	11.2	5.8
40	79.2	55	17	38.5	6.6	4	33	39	3.2	64	64	78	11.2	7
50	81.7	55.5	18	43.5	9	5	39	32.5	3.2	79	78	95	14.7	8

Foot bracket material: Carbon steel
Surface treatment: Nickel plated

* For details about the rod end nut and accessory brackets, refer to page 23.

Rod end male thread

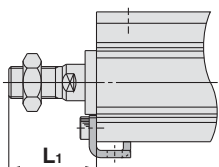

Compact foot: C□Q2LC

The dimensions are the same with or without an auto switch.

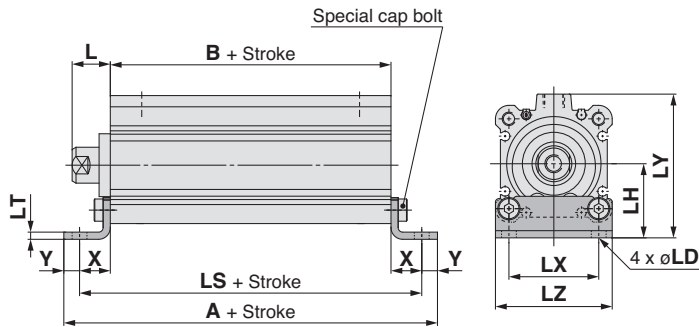

Compact Foot (mm)

Bore size (mm)	A	B	L	L ₁	LD	LH	LS	LT	LX	LY	LZ	X	Y
32	84.5	45.5	17	38.5	6.6	30	72.9	3.2	34	57	45	13.7	5.8
40	96.4	55	17	38.5	6.6	33	82.4	3.2	40	64	52	13.7	7
50	104.9	55.5	18	43.5	9	39	88.9	3.2	50	78	64	16.7	8

Compact foot bracket material: Carbon steel
Surface treatment: Zinc chromated

Rod end male thread

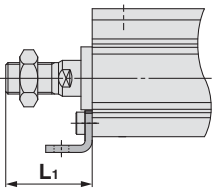

Rod flange: C□Q2F

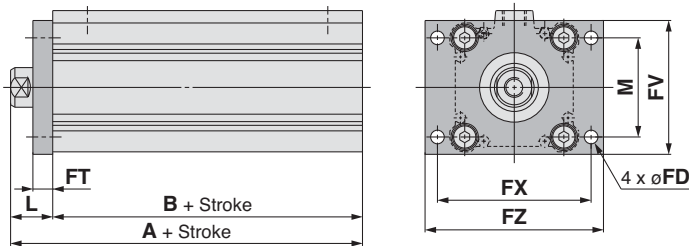

Rod Flange (mm)

Bore size (mm)	A	B	FD	FT	FV	FX	FZ	L	L ₁	M
32	62.5	45.5	5.5	8	48	56	65	17	38.5	34
40	72	55	5.5	8	54	62	72	17	38.5	40
50	73.5	55.5	6.6	9	67	76	89	18	43.5	50

Flange bracket material: Carbon steel
Surface treatment: Nickel plated

Rod end male thread

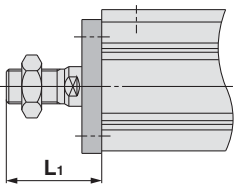

Head flange: C□Q2G

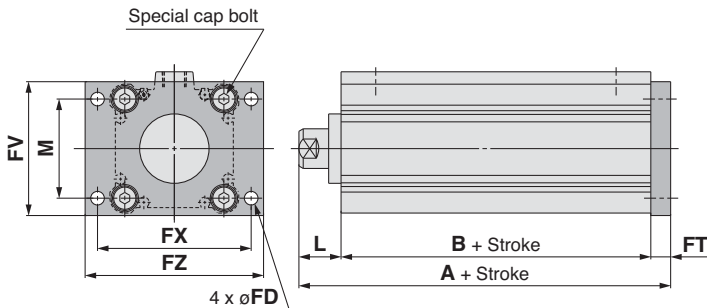

Head Flange (mm)

Bore size (mm)	A
32	70.5
40	80
50	82.5

* The dimensions except A are the same as those of the rod flange.

Flange bracket material: Carbon steel
Surface treatment: Nickel plated

Rod end male thread

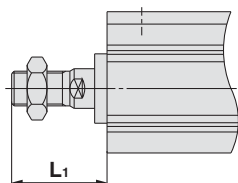

Standard

Large Bore Size

Long Stroke

Non-rotating Rod

Axial Piping

Anti-lateral Load

With End Lock

Water Resistant

With Auto Switch

Auto Switch

Made to Order

The dimensions are the same with or without an auto switch.

Double clevis: C□Q2D

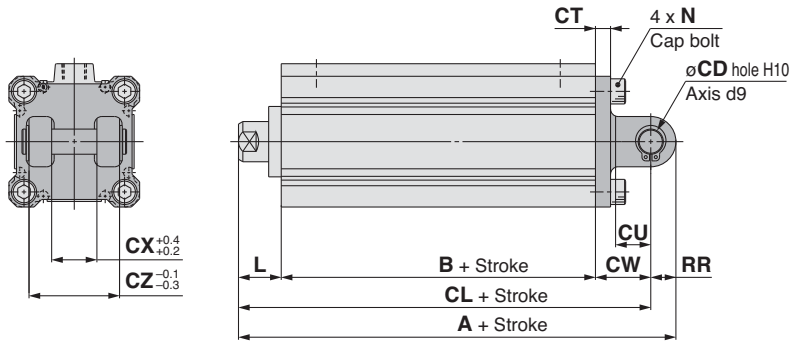

Rod end male thread

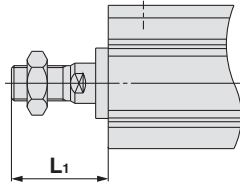

Double Clevis

Bore size (mm)	A	B	CD	CL	CT	CU	CW	CX	CZ
32	92.5	45.5	10	82.5	5	14	20	18	36
40	104	55	10	94	6	14	22	18	36
50	115.5	55.5	14	101.5	7	20	28	22	44

Bore size (mm)	L	L ₁	N	RR
32	17	38.5	M6 x 1.0	10
40	17	38.5	M6 x 1.0	10
50	18	43.5	M8 x 1.25	14

Double clevis bracket material: Cast iron
Surface treatment: Painted

- * For details about the rod end nut and accessory brackets, refer to page 23.
- * Double clevis pin and retaining rings are shipped together.

Series CQ2

Dimensions

Ø63 to Ø100

The dimensions are the same with or without an auto switch.

Both ends tapped: C□Q2A

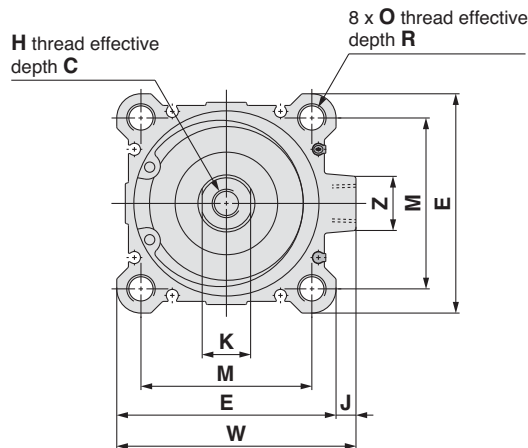
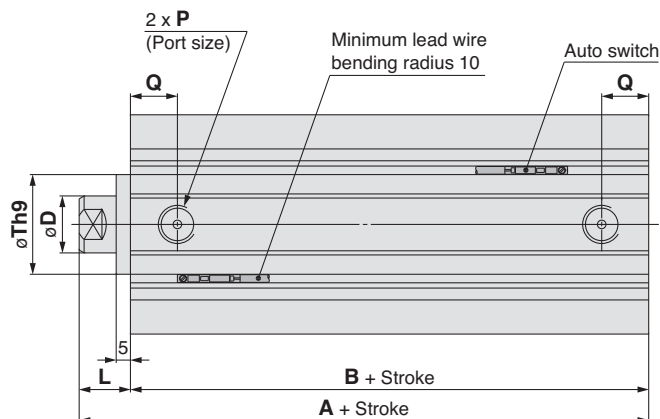

Rod end male thread

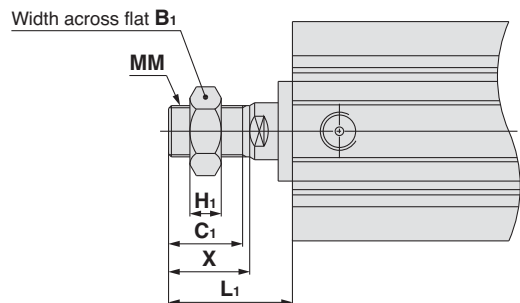

Rod End Male Thread (mm)

Bore size (mm)	B ₁	C ₁	H ₁	L ₁	MM	X
63	27	26	11	43.5	M18 x 1.5	28.5
80	32	32.5	13	53.5	M22 x 1.5	35.5
100	41	32.5	16	53.5	M26 x 1.5	35.5

The dimensions with built-in one-touch fittings are equivalent to those of the CQ2 series, double acting, single rod. Refer to page 20.

Both Ends Tapped For auto switch proper mounting position and its mounting height, refer to pages 193 to 199. (mm)

Bore size (mm)	Stroke range (mm)	A	B	C	D	E	H	J	K	L	M	O	P	Q	R	Th9	W	Z
63	125 to 200 (Note 1) 250, 300	75	57	15	20	77	M10 x 1.5	7	17	18	60	M10 x 1.5	1/4	16.5	18	35 ⁰ _{-0.062}	84	19
80		86	66	21	25	98	M16 x 2.0	6	22	20	77	M12 x 1.75	3/8	19	22	43 ⁰ _{-0.062}	104	25
100		97.5	75.5	27	30	117	M20 x 2.5	6.5	27	22	94	M12 x 1.75	3/8	23	22	59 ⁰ _{-0.074}	123.5	25

Note 1) For 125 to 200 strokes, strokes are available in 25 mm intervals.

Note 2) For calculation on the longitudinal dimension of intermediate strokes, refer to page 84.

Foot: C□Q2L

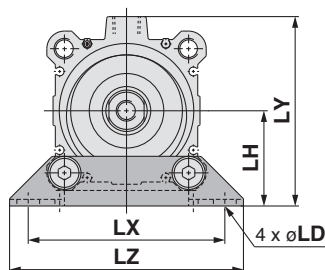
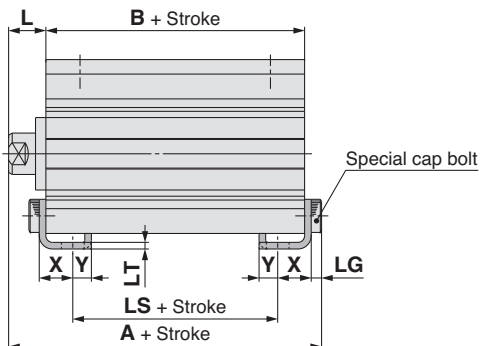

Rod end male thread

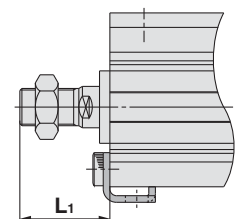

Foot

Bore size (mm)	A	B	L	L ₁	LD	LG	LH	LS	LT	LX	LY	LZ	X	Y
63	83.2	57	18	43.5	11	5	46	31	3.2	95	91.5	113	16.2	9
80	97.5	66	20	53.5	13	7	59	36	4.5	118	114	140	19.5	11
100	110.5	75.5	22	53.5	13	7	71	41.5	6	137	136	162	23	12.5

Foot bracket material: Carbon steel
Surface treatment: Nickel plated

* For details about the rod end nut and accessory brackets, refer to page 23.

The dimensions are the same with or without an auto switch.

Compact foot: C□Q2LC

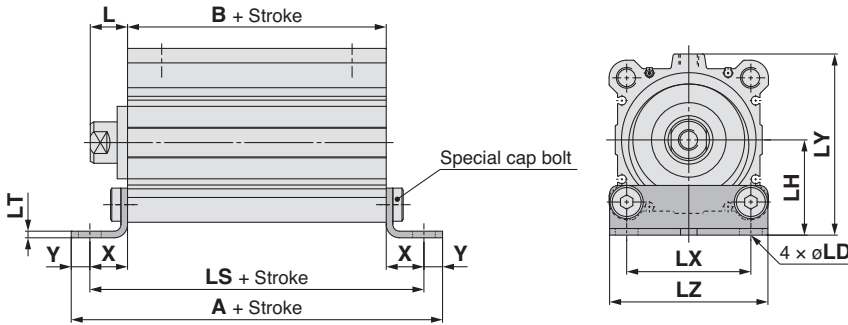

Rod end male thread

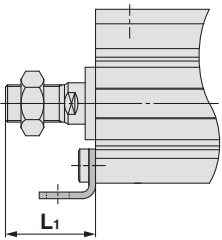

Compact Foot

Bore size (mm)	A	B	L	L ₁	LD	LH	LS	LT	LX	LY	LZ	X	Y
63	111.4	57	18	43.5	11	46	93.4	3.2	60	91.5	77	18.2	9
80	133	66	20	53.5	13	59	111	4.5	77	114	98	22.5	11
100	148.5	75.5	22	53.5	13	71	123.5	6	94	136	117	24	12.5

Compact foot bracket material: Carbon steel
Surface treatment: Zinc chromated

Rod flange: C□Q2F

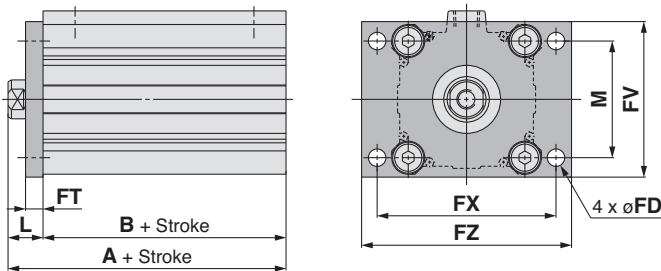

Rod Flange

Bore size (mm)	A	B	FD	FT	FV	FX	FZ	L	L ₁	M
63	75	57	9	9	80	92	108	18	43.5	60
80	86	66	11	11	99	116	134	20	53.5	77
100	97.5	75.5	11	11	117	136	154	22	53.5	94

Flange bracket material: Carbon steel
Surface treatment: Nickel plated

Rod end male thread

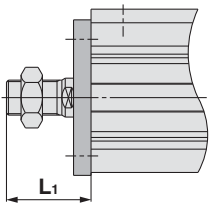

Head flange: C□Q2G

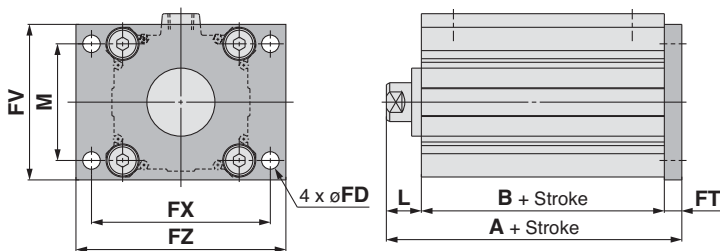

Head Flange

Bore size (mm)	A
63	84
80	97
100	108.5

(* The dimensions except A are the same as those of the rod flange.)

Flange bracket material: Carbon steel
Surface treatment: Nickel plated

Rod end male thread

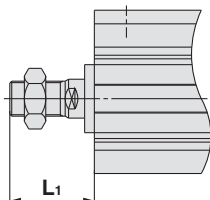

Standard

Large Bore Size

Long Stroke

Non-rotating Rod

Axial Piping

Anti-lateral Load

With End Lock

Water Resistant

With Auto Switch

Auto Switch

Made to Order

The dimensions are the same with or without an auto switch.

Double clevis: C□Q2D

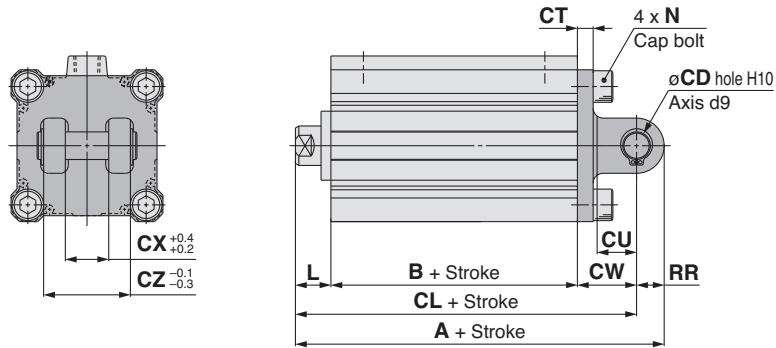

Double Clevis

(mm)

Bore size (mm)	A	B	CD	CL	CT	CU	CW	CX	CZ
63	119	57	14	105	8	20	30	22	44
80	142	66	18	124	10	27	38	28	56
100	164.5	75.5	22	142.5	13	31	45	32	64

Bore size (mm)	L	L ₁	N	RR
63	18	43.5	M10 x 1.5	14
80	20	53.5	M12 x 1.75	18
100	22	53.5	M12 x 1.75	22

Double clevis bracket material: Cast iron
Surface treatment: Nickel plated

- * For details about the rod end nut and accessory brackets, refer to page 23.
- * Double clevis pin and retaining rings are shipped together.

Rod end male thread

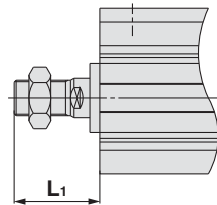

Compact Cylinder: Non-rotating Rod Double Acting, Single Rod Series CQ2K

ø12, ø16, ø20, ø25, ø32, ø40, ø50, ø63

How to Order

Without auto switch
ø12 to ø25

Without auto switch
ø32 to ø63

With auto switch

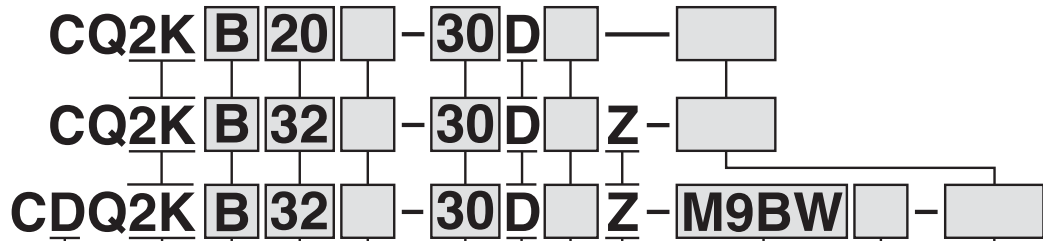

With auto switch
(Built-in magnet)

Non-rotating rod

Mounting

B	Through-hole (Standard)	ø12 to ø63
A	Both ends tapped	
L	Foot	
LC	Compact Foot	ø40, ø50, ø63
F	Rod flange	
G	Head flange	
D	Double clevis	

* Mounting brackets are shipped together, (but not assembled).
* Cylinder mounting bolts are not included. Order them separately referring to "Mounting Bolt for C(D)Q2KB" on pages 98 and 100.

Bore size

12 Note 1)	12 mm	32	32 mm
16	16 mm	40	40 mm
20	20 mm	50	50 mm
25	25 mm	63	63 mm

Note 1) When ø12 with auto switch is required, the body option should be with rubber bumper (C).
Example) CDQ2KB12-30DCZ

Port thread type

—	M thread	ø12 to ø25
TN	NPT	ø32 to ø63
TF	G	
F	Built-in one-touch fittings Note 2)	

Note 2) Bore sizes available with one-touch fittings are ø32 to ø63.

* For cylinders without auto switch, M threads are compatible only for ø32-5 mm stroke model.

Cylinder stroke (mm)

Refer to the next page for standard strokes.

Number of auto switches

—	2 pcs.
S	1 pc.
n	"n" pcs.

Auto switch

—	Without auto switch
---	---------------------

* Refer to the below table for applicable auto switches.

Auto switch mounting groove

Z	ø12 to ø25	2 surfaces
	ø32 to ø63	4 surfaces

Made to Order

Refer to the next page for details.

Body option

—	Standard (Rod end female thread)
F	With boss on head end
C	With rubber bumper (ø12 with auto switch only)
M	Rod end male thread

* Combination of body options ("FM") is available.

Action

D	Double acting
----------	---------------

Built-in Magnet Cylinder Model

If a built-in magnet cylinder without an auto switch is required, there is no need to enter the symbol for the auto switch.
(Example) CDQ2KL32-30DZ

Applicable Auto Switches

Refer to pages 1263 to 1371 in Best Pneumatics No. 2 for further information on auto switches.

Type	Special function	Electrical entry	Indicator light	Wiring (Output)	Load voltage		Auto switch model		Lead wire length (m)					Pre-wired connector	Applicable load			
					DC	AC	Perpendicular	In-line	0.5 (-)	1 (M)	3 (L)	5 (Z)	None (N)					
Solid state auto switch	—	Grommet	Yes	3-wire (NPN)	24 V	5 V, 12 V	—	M9NV	M9N	●	●	●	○	—	○	IC circuit		
				3-wire (PNP)				M9PV	M9P	●	●	●	○	—	○			
				2-wire				M9BV	M9B	●	●	●	○	—	○		—	
				3-wire (NPN)				M9NWV	M9NW	●	●	●	○	—	○			
	Diagnostic indication (2-colour indication)			3-wire (PNP)				M9PWV	M9PW	●	●	●	○	—	○		IC circuit	
				2-wire				M9BWW	M9BW	●	●	●	○	—	○			—
	Water resistant (2-colour indication)			3-wire (NPN)				M9NAV**	M9NA**	○	○	●	○	—	○		IC circuit	
				3-wire (PNP)				M9PAV**	M9PA**	○	○	●	○	—	○			
	Magnetic field resistant (2-colour indication)			2-wire				M9BAV**	M9BA**	○	○	●	○	—	○		—	
				2-wire (Non-polar)				—	P3DW	●	—	●	●	—	○			
Reed auto switch	—	Grommet	Yes	3-wire (NPN equivalent)	24 V	5 V	—	A96V	A96	●	—	●	—	—	—	IC circuit	—	
				2-wire				A93V	A93	●	—	●	—	—	—	—		Relay, PLC
								A90V	A90	●	—	●	—	—	—	—		IC circuit

* Water resistant type auto switches can be mounted on the above models, but in such case SMC cannot guarantee water resistance. Consult with SMC regarding water resistant types with the above model numbers.

* Lead wire length symbols: 0.5 m — (Example) M9NV
1 m M (Example) M9NWM
3 m L (Example) M9NWL
5 m Z (Example) M9NWZ

* Solid state auto switches marked with "○" are produced upon receipt of order.
* The D-P3DW□ type is available from ø32 to ø63 only.

* There are other applicable auto switches other than the listed above. For details, refer to page 199.

* For details about auto switches with pre-wired connector, refer to pages 1328 and 1329 in Best Pneumatics No. 2.

Series CQ2K



Symbol
Non-rotating rod

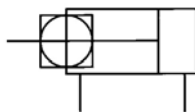

Made to Order
(For details, refer to pages 201 to 235.)

Symbol	Specifications
-XA□	Special rod end shape
-XB10	Intermediate stroke (Exclusive body type): ø40 to ø63
-XC2(A)	Rod end length, 10 mm increased (For foot and flange bracket)
-XC8	Adjustable stroke cylinder/Adjustable extension type
-XC9	Adjustable stroke cylinder/Adjustable retraction type
-XC10	Dual stroke cylinder/Double rod
-XC11	Dual stroke cylinder/Single rod
-XC26	With split pins for double clevis pin/ double knuckle joint pin and flat washers
-X1876	Cylinder tube: With concave boss on head side

Refer to pages 193 to 199 for the specifications of cylinders with autoswitches.

- Auto switch proper mounting position (detection at stroke end) and its mounting height
- Minimum stroke for auto switch mounting
- Operating range
- Auto switch mounting brackets/Part no.

Specifications

Bore size (mm)	12	16	20	25	32	40	50	63
Action	Double acting, Single rod							
Fluid	Air							
Proof pressure	1.5 MPa							
Maximum operating pressure	1.0 MPa							
Minimum operating pressure	0.07 MPa		0.05 MPa					
Ambient and fluid temperature	Without auto switch: -10 to 70°C (No freezing) With auto switch: -10 to 60°C (No freezing)							
Lubrication	Not required (Non-lube)							
Piston speed	50 to 500 mm/s							
Allowable kinetic energy (J)	0.022 0,043 Note 1)	0.038	0.055	0.09	0.15	0.26	0.46	0.77
Stroke length tolerance	+1.0 mm Note 2) 0							
Rod non-rotating accuracy	±2°		±1°			±0.8°		

* ø12 with auto switch: With rubber bumper (Standard)

Note 1) For cylinders with rubber bumper (ø12 with auto switch only)

Note 2) Stroke length tolerance does not include the amount of bumper change.

Standard Strokes

Bore size	Standard stroke (mm)
12, 16	5, 10, 15, 20, 25, 30
20, 25	5, 10, 15, 20, 25, 30, 35, 40, 45, 50
32, 40	5, 10, 15, 20, 25, 30, 35, 40, 45, 50, 75, 100
50, 63	10, 15, 20, 25, 30, 35, 40, 45, 50, 75, 100

Manufacture of Intermediate Strokes

Type	A spacer is installed in the standard stroke body.	
Part no.	Refer to "How to Order" for the standard model number. (P. 94)	
Description	Strokes in 1 mm intervals are available by installing a spacer in the standard stroke cylinder.	
Stroke range	Bore size	Stroke range
	12, 16	1 to 29
	20, 25	1 to 49
	32 to 63	1 to 99
Example	Part no.: CQ2KB50-57DZ CQ2KB50-75DZ with 18 mm width spacer inside The B dimension is 115.5 mm.	

Type

Bore size (mm)		12	16	20	25	32	40	50	63		
Pneumatic	Mounting	Through-hole (Standard)	●	●	●	●	●	●	●		
		Both ends tapped	—	—	—	—	●	●	●		
	Built-in magnet		●	●	●	●	●	●	●		
	Piping	Pipe thread	—	M5	M5	M5	M5	Note 1) M5 Rc1/8	Rc1/8	Rc1/4	Rc1/4
			TN	—	—	—	—	NPT1/8	NPT1/8	NPT1/4	NPT1/4
			TF	—	—	—	—	G1/8	G1/8	G1/4	G1/4
		Built-in one-touch fittings	—	—	—	—	ø6/4 Note 2)	ø6/4	ø8/6	ø8/6	
	Rod end male thread		●	●	●	●	●	●	●	●	
	With boss on head end		●	●	●	●	●	●	●	●	

Note 1) ø32 without auto switch: M5 is used for 5 mm strokekeeping dimension.

Thus, do not enter a symbol for the port thread type.

Note 2) The dimensions of the ø32-5 mm stroke with built-in one-touch fittings are the same as those of the 10 mm stroke cylinder tube.

Retaining Ring Installation/Removal

⚠ Caution

- For installation and removal, use an appropriate pair of pliers (tool for installing a type C retaining ring).
- Even if a proper plier (tool for installing a type C retaining ring) is used, it is likely to inflict damage to a human body or peripheral equipment, as a retaining ring may be flown out of the tip of a plier (tool for installing a type C retaining ring). Be much careful with the popping of a retaining ring. Besides, be certain that a retaining ring is placed firmly into the groove of rod cover before supplying air at the time of installment.

Mounting

- Install or remove loads while the piston rod width across flat is secured.

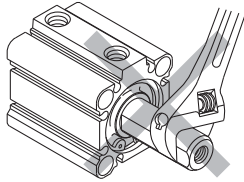

- Using a non-rotating rod cylinder
Avoid using the air cylinder in such a way that rotational torque would be applied to the piston rod. If rotational torque is applied, the non-rotating guide will deform, causing a loss of non-rotating accuracy.
Use the below table as a guide for the allowable rotational torque ranges.

Allowable rotational torque	12	16	20	25	32	40	50	63
N·m or less	0.04	0.15	0.20	0.25	0.44	0.44	0.44	0.44

Operate the cylinder in such a way that the load to the piston rod is always applied in the axial direction.

- When a work piece is secured to the end of the piston rod, ensure that the piston rod is retracted entirely, and place a wrench on the portion of the rod that protrudes beyond the section. Also, tighten in a way that prevents the tightening torque from being applied to the non-rotating guide.

Mounting Brackets/Part No.

Bore size (mm)	Note 1) Foot	Note 1) Compact Foot	Flange	Double clevis
40	CQ-L040	CQ-LC040	CQ-F040	CQ-D040
50	CQ-L050	CQ-LC050	CQ-F050	CQ-D050
63	CQ-L063	CQ-LC063	CQ-F063	CQ-D063

Note 1) When ordering a foot, and compact foot brackets, order 2 pieces per cylinder.

Note 2) Parts belonging to each bracket are as follows.
Foot, Compact foot, Flange: Body mounting bolts
Double clevis: Clevis pin, Body mounting bolts, Type C retaining rings for axis

Theoretical Output

Bore size (mm)	Operating direction	Operating pressure (MPa)		
		0.3	0.5	0.7
12	IN	25	42	59
	OUT	34	57	79
16	IN	45	75	106
	OUT	60	101	141
20	IN	71	118	165
	OUT	94	157	220
25	IN	113	189	264
	OUT	147	245	344
32	IN	181	302	422
	OUT	241	402	563
40	IN	317	528	739
	OUT	377	628	880
50	IN	495	825	1150
	OUT	589	982	1370
63	IN	841	1400	1960
	OUT	935	1560	2180

Weight

Weight

Bore size (mm)	Cylinder stroke (mm)											
	5	10	15	20	25	30	35	40	45	50	75	100
12	60	67	74	81	88	95	—	—	—	—	—	—
16	58	67	76	85	94	103	—	—	—	—	—	—
20	103	117	131	145	159	173	187	201	215	229	—	—
25	137	152	167	182	197	212	227	242	257	272	—	—
32	196	215	234	253	272	291	310	329	347	366	506	601
40	205	226	248	269	291	312	333	355	376	398	570	682
50	—	356	390	424	457	491	525	559	592	626	901	1075
63	—	524	563	602	641	680	720	759	798	837	1173	1375

Additional Weight

Bore size (mm)		12	16	20	25	32	40	50	63
Both ends tapped		—	—	—	—	—	6	6	19
Rod end male thread	Male thread	1.5	3	6	12	26	27	53	53
	Nut	1	2	4	8	17	17	32	32
With boss on head side		0.7	1.3	2	3	5	7	13	25
Built-in one-touch fittings		—	—	—	—	12	12	21	21
Foot (Including mounting bolts)		—	—	—	—	—	153	242	316
Compact foot (Including mounting bolts)		41	51	121	140	99	114	177	241
Rod flange (Including mounting bolts)		—	—	—	—	—	213	372	558
Head flange (Including mounting bolts)		—	—	—	—	—	198	348	534
Double clevis (Including pin, retaining rings, bolts)		—	—	—	—	—	196	393	554

Calculation: (Example) **CQ2KD40-20DMZ**

- Basic weight: CQ2KB40-20DZ 269 g
 - Additional weight: Both ends tapped 6 g
 - Rod end male thread 44 g
 - Double clevis 196 g
- 515 g

Standard
Large Bore Size
Long Stroke
Non-rotating Rod
Axial Piping
Anti-lateral Load
With End Lock
Water Resistant
With Auto Switch
Auto Switch
Made to Order

Series CQ2K

Construction

Standard (ø12 to ø32)

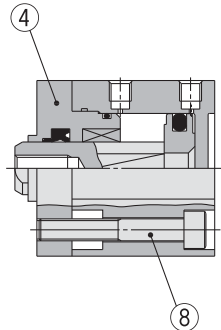

Standard (ø40 to ø63)

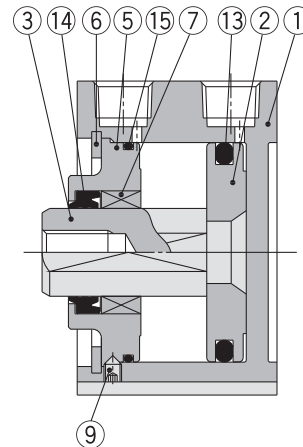

Built-in one-touch fittings

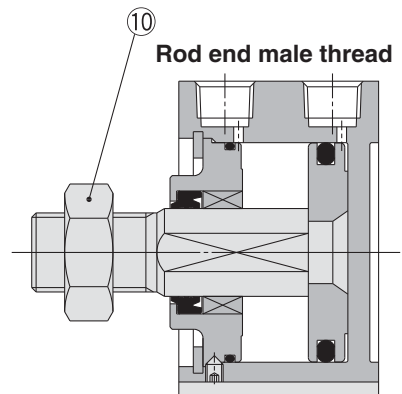
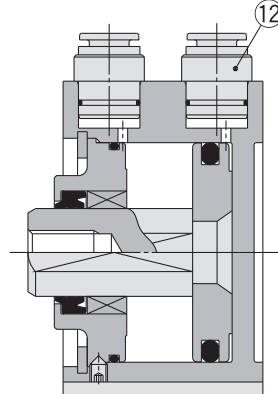
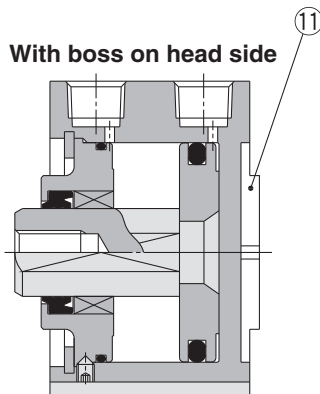

Component Parts

No.	Description	Material	Note
1	Cylinder tube	Aluminum alloy	Hard anodised
2	Piston	Aluminum alloy	Chromated
3	Piston rod	Stainless steel	ø12 to ø25
		Carbon steel	ø32 to ø63, Hard chrome plated
4	Rod cover	Brass	ø12, Electroless nickel plated
		Aluminum alloy	ø16 to ø32, Anodised
5	Collar	Aluminum alloy	ø40 to ø63, Anodised
6	Retaining ring	Carbon tool steel	Phosphate coated
7	Bushing	Oil-impregnated sintered alloy	ø16 to ø63
8	Hexagon socket head cap screw	Alloy steel	ø12 to ø32, Nickel plated
9	Hexagon socket head set screw	Alloy steel	ø40 to ø63, Nickel plated
10	Rod end nut	Carbon steel	Nickel plated
11	Centering location ring	Aluminum alloy	ø20 to ø63, Anodised
12	One-touch fitting	—	ø32 to ø63
13	Piston seal	NBR	
14	Rod seal	NBR	
15	Tube gasket	NBR	

Replacement Parts/Seal Kit

Bore size (mm)	Kit no.	Contents
12	CQ2KB12-PS	Kits include items 13, 14, 15 from the table.
16	CQ2KB16-PS	
20	CQ2KB20-PS	
25	CQ2KB25-PS	
32	CQ2KB32-PS	
40	CQ2KB40-PS	
50	CQ2KB50-PS	
63	CQ2KB63-PS	

* Seal kit includes 13, 14, 15. Order the seal kit based on each bore size.

* Since the seal kit does not include a grease pack, order it separately.

Grease pack part no.: GR-S-010 (10 g)

Mounting Bolt for CQ2KB/Without Auto Switch

Mounting method: Mounting bolt for through-hole mounting of the CQ2KB is available as an option. Refer to the following for ordering procedures. Order the actual number of bolts that will be used.

Example) CQ-M3 x 30L 2 pcs.

Material: Chromium molybdenum steel
Surface treatment: Zinc chromated

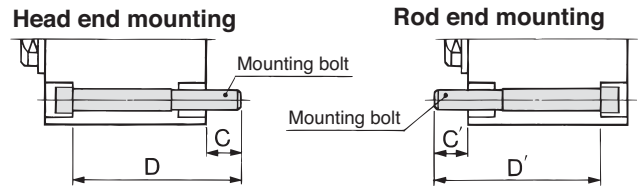

Cylinder model	C	D	Mounting bolt part no.	C'	D'	Mounting bolt part no.
CQ2KB12-5D	6.5	30	CQ-M3 x 30L	6.5	30	CQ-M3 x 30L
-10D		35	x 35L		35	x 35L
-15D		40	x 40L		40	x 40L
-20D		45	x 45L		45	x 45L
-25D		50	x 50L		50	x 50L
-30D		55	x 55L		55	x 55L
CQ2KB16-5D	5	30	CQ-M3 x 30L	5	30	CQ-M3 x 30L
-10D		35	x 35L		35	x 35L
-15D		40	x 40L		40	x 40L
-20D		45	x 45L		45	x 45L
-25D		50	x 50L		50	x 50L
-30D		55	x 55L		55	x 55L
CQ2KB20-5D	8	35	CQ-M5 x 35L	9.5	35	CQ-M5 x 35L
-10D		40	x 40L		40	x 40L
-15D		45	x 45L		45	x 45L
-20D		50	x 50L		50	x 50L
-25D		55	x 55L		55	x 55L
-30D		60	x 60L		60	x 60L
-35D		65	x 65L		65	x 65L
-40D		70	x 70L		70	x 70L
-45D		75	x 75L		75	x 75L
-50D		80	x 80L		80	x 80L
CQ2KB25-5D	10	40	CQ-M5 x 40L	6.5	35	CQ-M5 x 35L
-10D		45	x 45L		40	x 40L
-15D		50	x 50L		45	x 45L
-20D		55	x 55L		50	x 50L
-25D		60	x 60L		55	x 55L
-30D		65	x 65L		60	x 60L
-35D		70	x 70L		65	x 65L
-40D		75	x 75L		70	x 70L
-45D		80	x 80L		75	x 75L
-50D		85	x 85L		80	x 80L
CQ2KB32-5DZ	8.5	40	CQ-M5 x 40L	10	40	CQ-M5 x 40L
-10DZ		45	x 45L		45	x 45L
-15DZ		50	x 50L		50	x 50L
-20DZ		55	x 55L		55	x 55L
-25DZ		60	x 60L		60	x 60L
-30DZ		65	x 65L		65	x 65L
-35DZ		70	x 70L		70	x 70L
-40DZ		75	x 75L		75	x 75L
-45DZ		80	x 80L		80	x 80L
-50DZ		85	x 85L		85	x 85L
-75DZ	120	x 120L	120	x 120L		
-100DZ	145	x 145L	145	x 145L		

Cylinder model	C	D	Mounting bolt part no.	C'	D'	Mounting bolt part no.
CQ2KB40-5DZ	7.5	35	CQ-M5 x 35L	7.5	35	CQ-M5 x 35L
-10DZ		40	x 40L		40	x 40L
-15DZ		45	x 45L		45	x 45L
-20DZ		50	x 50L		50	x 50L
-25DZ		55	x 55L		55	x 55L
-30DZ		60	x 60L		60	x 60L
-35DZ		65	x 65L		65	x 65L
-40DZ		70	x 70L		70	x 70L
-45DZ		75	x 75L		75	x 75L
-50DZ		80	x 80L		80	x 80L
-75DZ	115	x 115L	115	x 115L		
-100DZ	140	x 140L	140	x 140L		
CQ2KB50-10DZ	12.5	45	CQ-M6 x 45L	12.5	45	CQ-M6 x 45L
-15DZ		50	x 50L		50	x 50L
-20DZ		55	x 55L		55	x 55L
-25DZ		60	x 60L		60	x 60L
-30DZ		65	x 65L		65	x 65L
-35DZ		70	x 70L		70	x 70L
-40DZ		75	x 75L		75	x 75L
-45DZ		80	x 80L		80	x 80L
-50DZ		85	x 85L		85	x 85L
-75DZ		120	x 120L		120	x 120L
-100DZ	145	x 145L	145	x 145L		
CQ2KB63-10DZ	14.5	50	CQ-M8 x 50L	14.5	50	CQ-M8 x 50L
-15DZ		55	x 55L		55	x 55L
-20DZ		60	x 60L		60	x 60L
-25DZ		65	x 65L		65	x 65L
-30DZ		70	x 70L		70	x 70L
-35DZ		75	x 75L		75	x 75L
-40DZ		80	x 80L		80	x 80L
-45DZ		85	x 85L		85	x 85L
-50DZ		90	x 90L		90	x 90L
-75DZ		125	x 125L		125	x 125L
-100DZ	150	x 150L	150	x 150L		

Copper and Fluorine-free Series (For CRT Manufacturing Process)

20 — CQ2KB Bore size — Stroke D(M)Z

•Copper and fluorine-free series • $\phi 16, \phi 20, \phi 25, \phi 32, \phi 40, \phi 50, \phi 63$

For preventing the influence of copper ions or halogen ions during CRT manufacturing processes, copper and fluorine materials are not used in the component parts.

Specifications

Bore size (mm)	16	20	25	32	40	50	63
Action	Double acting, Single rod						
Proof pressure	1.5 MPa						
Max. operating pressure	1.0 MPa						
Rubber bumper	None						
Piping	Pipe thread						
Piston speed	50 to 500 mm/s						
Mounting	Through-hole						
Auto switch	Mountable						

Standard
Large Bore Size
Long Stroke
Non-rotating Rod
Axial Piping
Anti-lateral Load
With End Lock
Water Resistant
With Auto Switch
Auto Switch
Made to Order

Non-rotating Rod: Double Acting, Single Rod Series CDQ2K With Auto Switch

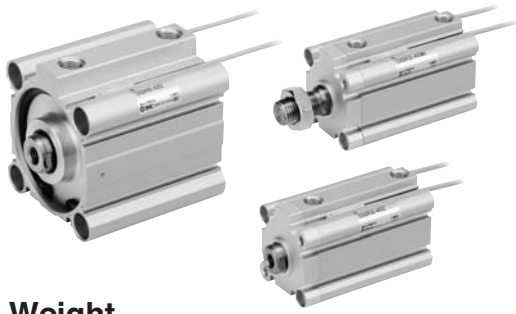

Refer to the below pages for further information on auto switches.

Auto switch proper mounting position and its mounting height	P.193 to 199
Minimum stroke for auto switch mounting	
Operating range	
Auto switch mounting brackets/Part no.	

Weight

Weight

Bore size (mm)	Cylinder stroke (mm)											
	5	10	15	20	25	30	35	40	45	50	75	100
12	71	77	83	89	96	102	—	—	—	—	—	—
16	74	82	89	97	105	113	—	—	—	—	—	—
20	119	132	144	156	168	180	192	204	217	229	—	—
25	162	177	192	208	223	238	254	269	284	300	—	—
32	227	247	266	286	306	326	345	365	385	404	504	604
40	240	261	283	305	326	348	369	391	413	434	546	658
50	—	433	466	499	532	565	598	630	663	697	869	1041
63	—	622	660	698	736	774	812	850	888	926	1124	1321

Additional Weight

Bore size (mm)	12	16	20	25	32	40	50	63
Both ends tapped	—	—	—	—	—	6	6	19
Rod end male thread	Male thread	1.5	3	6	12	26	27	53
	Nut	1	2	4	8	17	17	32
With boss on head side	0.7	1.3	2	3	5	7	13	25
Built-in one-touch fittings	—	—	—	—	12	12	21	21
Foot (Including mounting bolts)	—	—	—	—	—	153	242	316
Compact foot (Including mounting bolts)	32	40	97	116	99	114	177	241
Rod flange (Including mounting bolts)	—	—	—	—	—	213	372	558
Head flange (Including mounting bolts)	—	—	—	—	—	198	348	534
Double clevis (Including pin, retaining rings and bolts)	—	—	—	—	—	196	393	554

Calculation: (Example) CDQ2KD40-25DMZ

- Basic weight: CDQ2KB40-25DZ 326 g
 - Additional weight: Both ends tapped 6 g
 - Rod end male thread 44 g
 - Double clevis 196 g
- 572 g

Add each weight of auto switches when auto switches are mounted.

Construction

ø12 to ø25

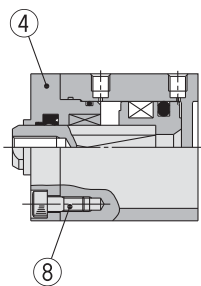

ø32

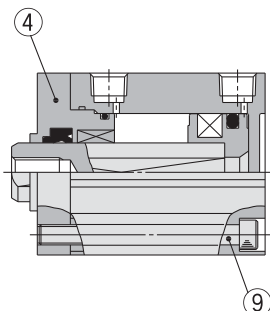

ø40 to ø63

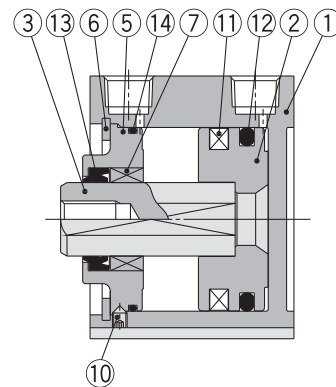

Component Parts

No.	Description	Material	Note
1	Cylinder tube	Aluminum alloy	Hard anodised
2	Piston	Aluminum alloy	Chromated
3	Piston rod	Stainless steel	ø12 to ø25
		Carbon steel	ø32 to ø63, Hard chrome plated
4	Rod cover	Brass	ø12, Electroless nickel plated
		Aluminum alloy	ø16 to ø32, Anodised
5	Collar	Aluminum alloy	ø40 to ø63, Anodised
6	Retaining ring	Carbon tool steel	Phosphate coated
7	Bushing	Oil-impregnated sintered alloy	ø16 to ø63
8	Hexagon socket head cap screw	Alloy steel	ø12 to ø25, Nickel plated
9	Hexagon socket head cap screw	Alloy steel	ø32, Nickel plated
10	Hexagon socket head set screw	Alloy steel	ø40 to ø63, Nickel plated
11	Magnet	—	—
12	Piston seal	NBR	—
13	Rod seal	NBR	—
14	Tube gasket	NBR	—

Replacement Parts/Seal Kit (Pneumatic type (Non-lube))

Bore size (mm)	Kit no.	Contents
12	CQ2KB12-PS	Kits include items 12, 13, 14 from the table.
16	CQ2KB16-PS	
20	CQ2KB20-PS	
25	CQ2KB25-PS	
32	CQ2KB32-PS	
40	CQ2KB40-PS	
50	CQ2KB50-PS	
63	CQ2KB63-PS	

* Seal kit includes 12, 13, 14. Order the seal kit, based on each bore size.

* Since the seal kit does not include a grease pack, order it separately.

Grease pack part no.: GR-S-010 (10 g)

Mounting Bolt for CDQ2KB/With Auto Switch

Mounting method: Mounting bolt for through-hole mounting of the CDQ2KB is available as an option. Refer to the following for ordering procedures. Order the actual number of bolts that will be used.

Example) CQ-M3 x 35L 2 pcs.

Material: Chromium molybdenum steel
Surface treatment: Zinc chromated

Head end mounting

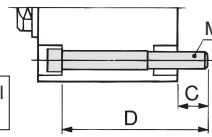

Rod end mounting

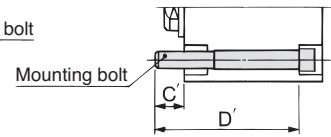

Cylinder model	C	D	Mounting bolt part no.	C'	D'	Mounting bolt part no.
CDQ2KB12-5DCZ	5.5	35	CQ-M3 x 35L	5.5	40	CQ-M3 x 40L
-10DCZ		40	x 40L		45	x 45L
-15DCZ		45	x 45L		50	x 50L
-20DCZ		50	x 50L		55	x 55L
-25DCZ		55	x 55L		60	x 60L
-30DCZ		60	x 60L		65	x 65L
CDQ2KB16-5DZ	8	40	CQ-M3 x 40L	8	45	CQ-M3 x 45L
-10DZ		45	x 45L		50	x 50L
-15DZ		50	x 50L		55	x 55L
-20DZ		55	x 55L		60	x 60L
-25DZ		60	x 60L		65	x 65L
-30DZ		65	x 65L		70	x 70L
CDQ2KB20-5DZ	10.5	40	CQ-M5 x 40L	7.5	45	CQ-M5 x 45L
-10DZ		45	x 45L		50	x 50L
-15DZ		50	x 50L		55	x 55L
-20DZ		55	x 55L		60	x 60L
-25DZ		60	x 60L		65	x 65L
-30DZ		65	x 65L		70	x 70L
-35DZ		70	x 70L		75	x 75L
-40DZ		75	x 75L		80	x 80L
-45DZ		80	x 80L		85	x 85L
-50DZ		85	x 85L		90	x 90L
CDQ2KB25-5DZ	9.5	40	CQ-M5 x 40L	6.5	45	CQ-M5 x 45L
-10DZ		45	x 45L		50	x 50L
-15DZ		50	x 50L		55	x 55L
-20DZ		55	x 55L		60	x 60L
-25DZ		60	x 60L		65	x 65L
-30DZ		65	x 65L		70	x 70L
-35DZ		70	x 70L		75	x 75L
-40DZ		75	x 75L		80	x 80L
-45DZ		80	x 80L		85	x 85L
-50DZ		85	x 85L		90	x 90L
CDQ2KB32-5DZ	8.5	50	CQ-M5 x 50L	10	50	CQ-M5 x 50L
-10DZ		55	x 55L		60	x 60L
-15DZ		60	x 60L		65	x 65L
-20DZ		65	x 65L		70	x 70L
-25DZ		70	x 70L		75	x 75L
-30DZ		75	x 75L		80	x 80L

Cylinder model	C	D	Mounting bolt part no.	C'	D'	Mounting bolt part no.
CDQ2KB32-40DZ	8.5	85	CQ-M5 x 85L	10	85	CQ-M5 x 85L
-45DZ		90	x 90L		90	x 90L
-50DZ		95	x 95L		95	x 95L
-75DZ		120	x 120L		120	x 120L
-100DZ		145	x 145L		145	x 145L
CDQ2KB40-5DZ		7.5	45		CQ-M5 x 45L	7.5
-10DZ	50		x 50L	50	x 50L	
-15DZ	55		x 55L	55	x 55L	
-20DZ	60		x 60L	60	x 60L	
-25DZ	65		x 65L	65	x 65L	
-30DZ	70		x 70L	70	x 70L	
-35DZ	75		x 75L	75	x 75L	
-40DZ	80		x 80L	80	x 80L	
-45DZ	85		x 85L	85	x 85L	
-50DZ	90		x 90L	90	x 90L	
-75DZ	115	x 115L	115	x 115L		
-100DZ	140	x 140L	140	x 140L		
CDQ2KB50-10DZ	12.5	55	CQ-M6 x 55L	12.5	55	CQ-M6 x 55L
-15DZ		60	x 60L		60	x 60L
-20DZ		65	x 65L		65	x 65L
-25DZ		70	x 70L		70	x 70L
-30DZ		75	x 75L		75	x 75L
-35DZ		80	x 80L		80	x 80L
-40DZ		85	x 85L		85	x 85L
-45DZ		90	x 90L		90	x 90L
-50DZ		95	x 95L		95	x 95L
-75DZ		120	x 120L		120	x 120L
-100DZ	145	x 145L	145	x 145L		
CDQ2KB63-10DZ	14.5	60	CQ-M8 x 60L	14.5	60	CQ-M8 x 60L
-15DZ		65	x 65L		65	x 65L
-20DZ		70	x 70L		70	x 70L
-25DZ		75	x 75L		75	x 75L
-30DZ		80	x 80L		80	x 80L
-35DZ		85	x 85L		85	x 85L
-40DZ		90	x 90L		90	x 90L
-45DZ		95	x 95L		95	x 95L
-50DZ		100	x 100L		100	x 100L
-75DZ		125	x 125L		125	x 125L
-100DZ	150	x 150L	150	x 150L		

Standard

Large Bore Size

Long Stroke

Non-rotating Rod

Axial Piping

Anti-lateral Load

With End Lock

Water Resistant

With Auto Switch

Auto Switch

Made to Order

Dimensions

∅12 to ∅25/With Auto Switch

Standard (Through-hole): CDQ2KB

∅12, ∅16

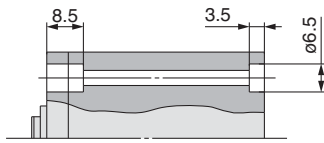

∅20, ∅25

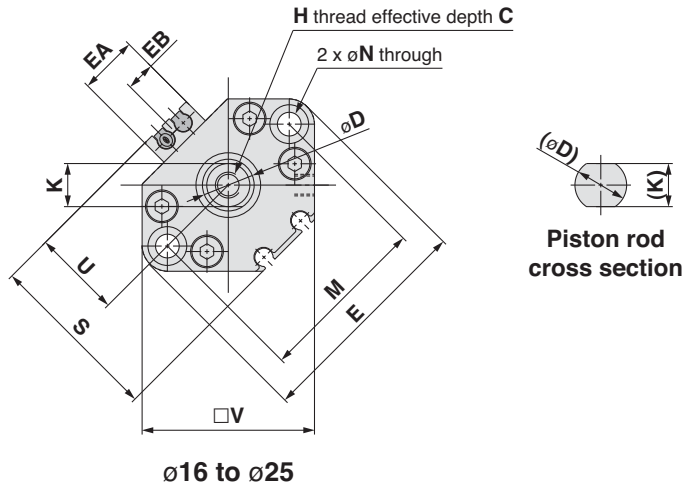
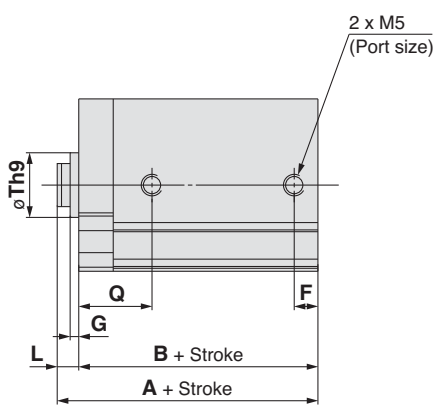
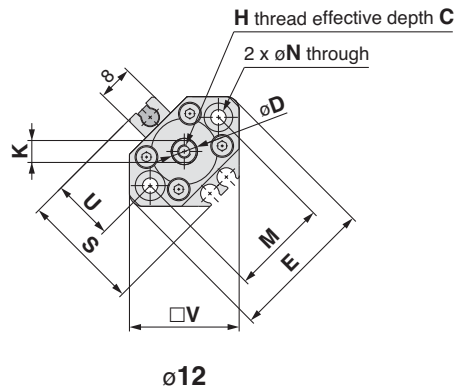
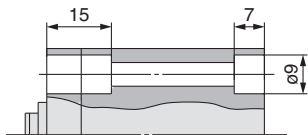

With boss on head end

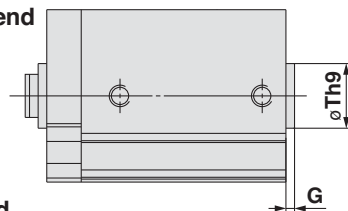

Rod end male thread

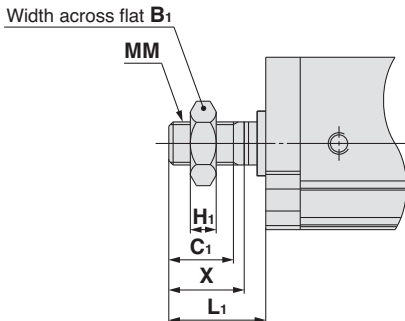

Rod End Male Thread (mm)

Bore size (mm)	B ₁	C ₁	H ₁	L ₁	MM	X
12	8	9	4	14	M5 x 0.8	10.5
16	10	10	5	15.5	M6 x 1.0	12
20	13	12	5	18.5	M8 x 1.25	14
25	17	15	6	22.5	M10 x 1.25	17.5

Standard For auto switch proper mounting position and its mounting height, refer to pages 193 to 199.

Bore size (mm)	Stroke range (mm)	A	B	C	D	E	EA	EB	F	G	H	K	L	M	N	Q	S	Th9	U	V
12	5 to 30	36.5	33	6	6	33	—	—	6.5	1.5	M3 x 0.5	5.2	3.5	22	3.5	16	27.5	15 ⁰ _{-0.043}	14	25
16	5 to 30	39	35.5	8	8	37	13.2	6.6	5.5	1.5	M4 x 0.7	6	3.5	28	3.5	15	29.5	20 ⁰ _{-0.052}	15	29
20	5 to 50	44	39.5	7	10	47	13.6	6.8	5.5	2	M5 x 0.8	8	4.5	36	5.5	16	35.5	13 ⁰ _{-0.043}	18	36
25	5 to 50	45.5	40.5	12	12	52	13.6	6.8	5.5	2	M6 x 1.0	10	5	40	5.5	17	40.5	15 ⁰ _{-0.043}	21	40

* For details about the rod end nut and accessory brackets, refer to page 23.

Standard
Large Bore Size
Long Stroke
Non-rotating Rod
Axial Piping
Anti-lateral Load
With End Lock
Water Resistant
With Auto Switch
Auto Switch
Made to Order

Series CQ2K

Dimensions

Ø32/Without Auto Switch

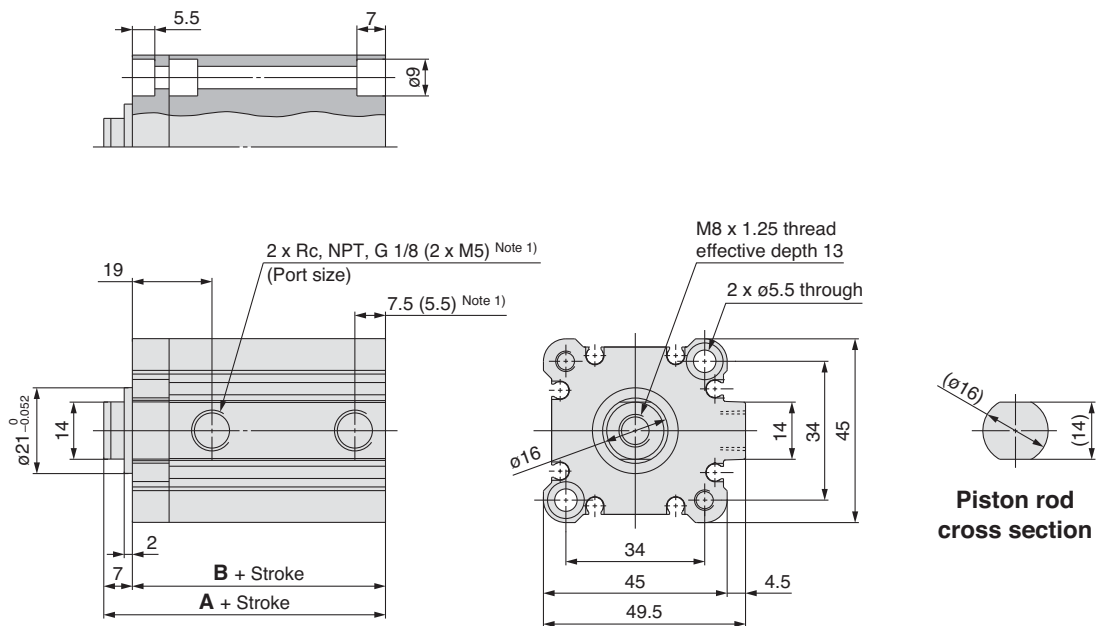

Note 1) () : Stroke 5 mm

With boss on head side

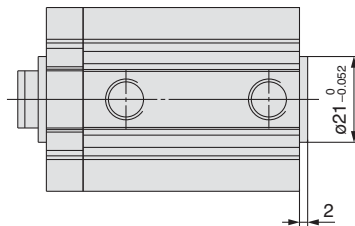

Stroke range (mm)	A	B
5 to 50	39	32
75, 100	49	42

Rod end male thread

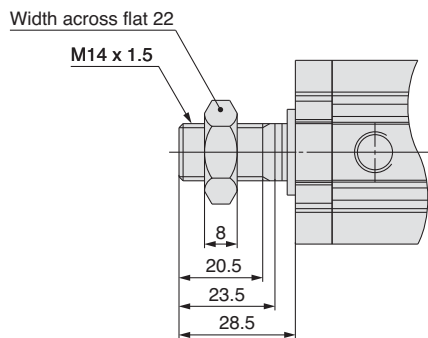

Built-in one-touch fittings: Ø32

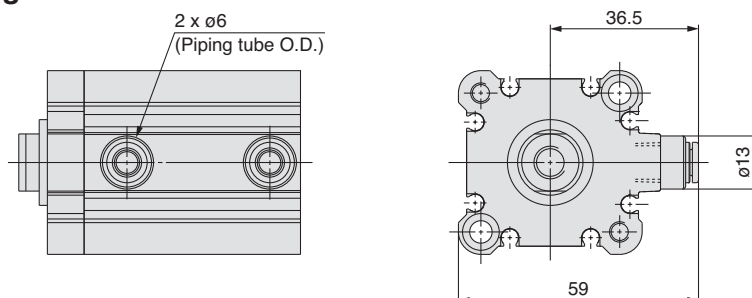

Note 2) The dimensions of the Ø32-5 mm stroke with built-in one-touch fittings are the same as those of the 10 mm stroke cylinder tube.

* For details about the rod end nut and accessory brackets, refer to page 23.

Dimensions

Ø32/With Auto Switch

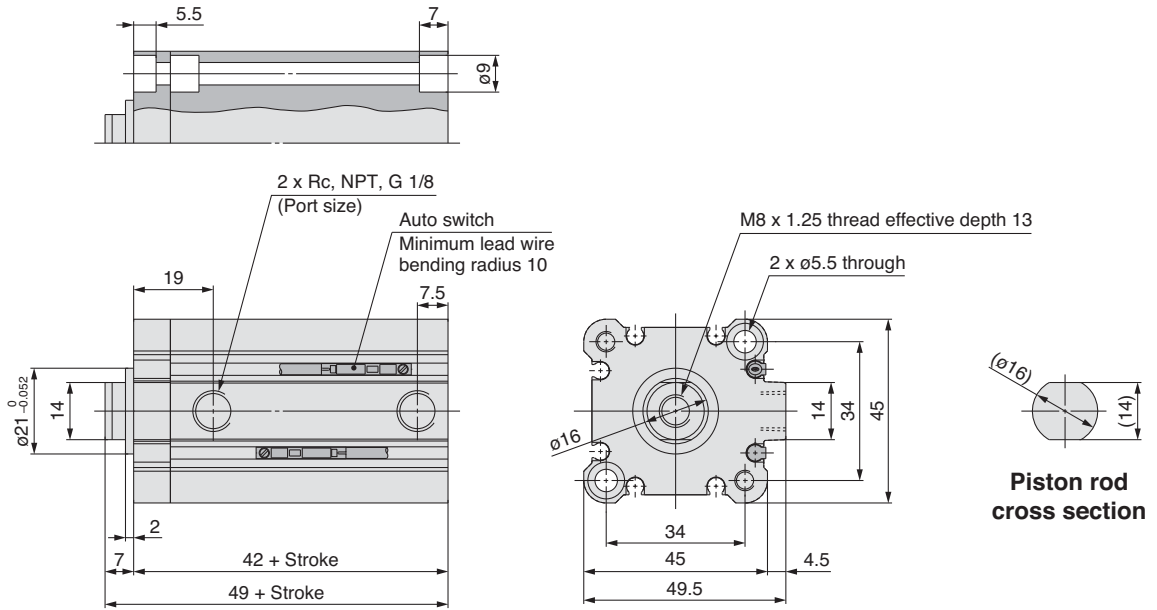

With boss on head end

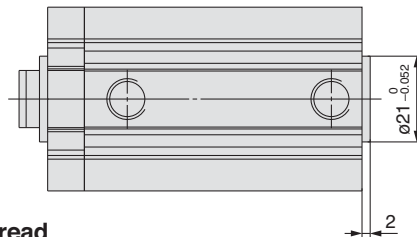

Rod end male thread

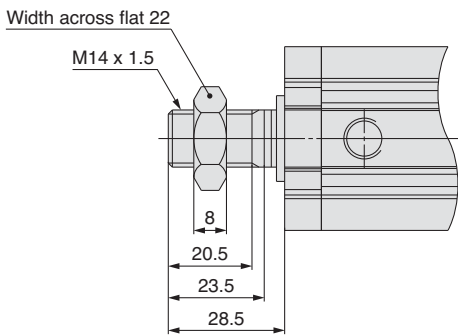

Built-in one-touch fittings: $\phi 32$

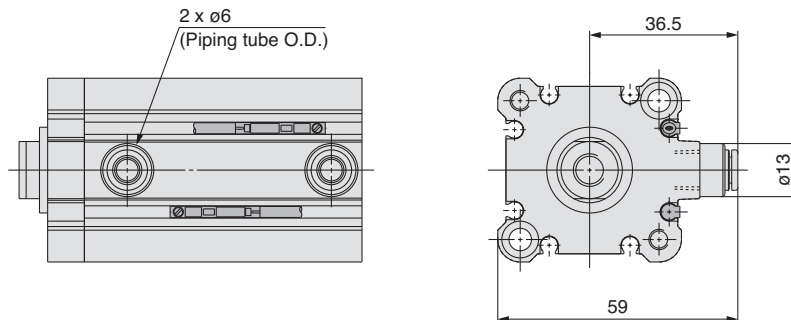

* For details about the rod end nut and accessory brackets, refer to page 23.

Standard
Large Bore Size
Long Stroke
Non-rotating Rod
Axial Piping
Anti-lateral Load
With End Lock
Water Resistant
With Auto Switch
Auto Switch
Made to Order

Series CQ2K

Dimensions

Ø40 to Ø63/With Auto Switch

(In the case of without auto switches, the A and B dimensions will be only changed. Refer to the dimension table.)

Both ends tapped: CDQ2KA

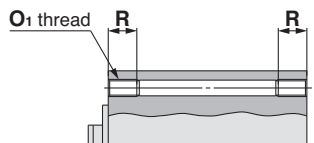

Both Ends Tapped (mm)

Bore size (mm)	O ₁	R
40	M6 x 1.0	10
50	M8 x 1.25	14
63	M10 x 1.5	18

Standard (Through-hole): CDQ2KB

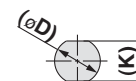
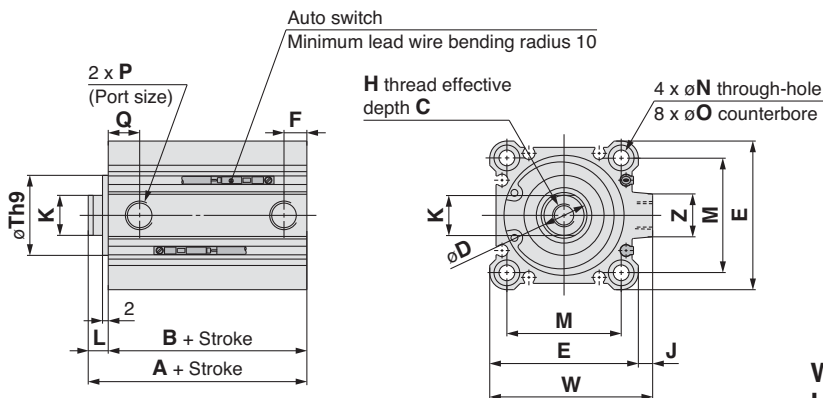

Piston rod cross section

With Boss on Head Side (mm)

Bore size (mm)	Th9
40	28 ⁰ _{-0.052}
50	35 ⁰ _{-0.062}
63	35 ⁰ _{-0.062}

With boss on head side

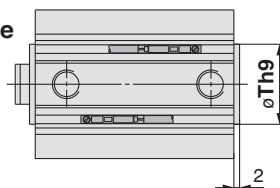

Rod end male thread

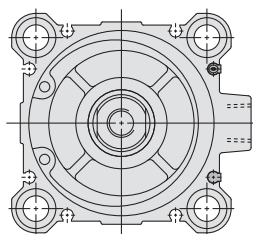
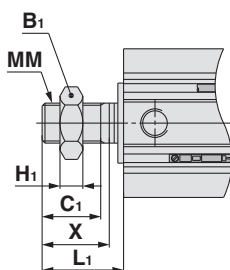

Cylinder tube form Ø63

Rod End Male Thread (mm)

Bore size (mm)	B ₁	C ₁	H ₁	L ₁	MM	X
40	22	20.5	8	28.5	M14 x 1.5	23.5
50	27	26	11	33.5	M18 x 1.5	28.5
63	27	26	11	33.5	M18 x 1.5	28.5

Built-in one-touch fittings: Ø40 to Ø63

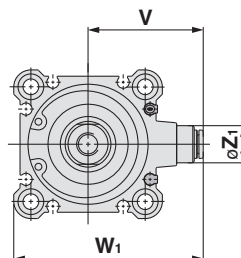
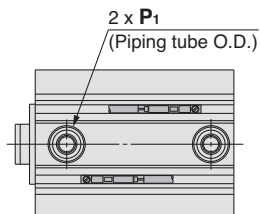

Built-in One-touch Fittings (mm)

Bore size (mm)	Z ₁	P ₁	V	W ₁
40	13	6	40.5	66.5
50	16	8	50	82
63	16	8	56.5	95

Standard

Bore size (mm)	Stroke range (mm)	Without auto switch		With auto switch		C	D	E	F	H	J	K	L	M	N	O	P	Q	Th9	W	Z
		A	B	A	B																
40	5 to 50	36.5	29.5	46.5	39.5	13	16	52	7.5	M8 x 1.25	5	14	7	40	5.5	9 depth 7	1/8	12.5	28 ⁰ _{-0.052}	57	15
	75, 100	46.5	39.5																		
50	10 to 50	38.5	30.5	48.5	40.5	15	20	64	10.5	M10 x 1.5	7	18	8	50	6.6	11 depth 8	1/4	10.5	35 ⁰ _{-0.062}	71	19
	75, 100	48.5	40.5																		
63	10 to 50	44	36	54	46	15	20	77	10.5	M10 x 1.5	7	18	8	60	9	14 depth 10.5	1/4	15	35 ⁰ _{-0.062}	84	19
	75, 100	54	46																		

* For details about the rod end nut and accessory brackets, refer to page 23.

Compact Cylinder: Non-rotating Rod Double Acting, Single Rod *Series CQ2K*

Foot: CDQ2KL

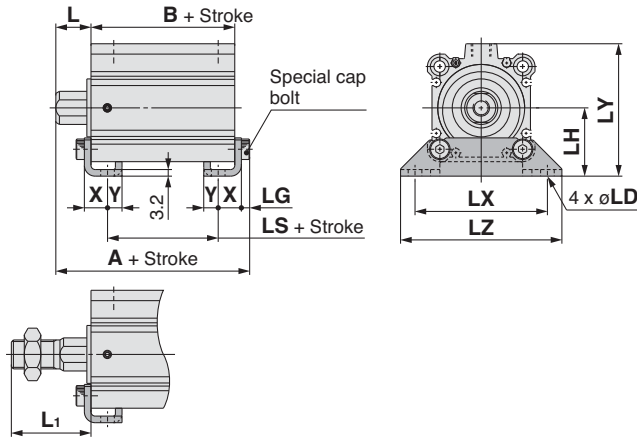

Foot

Bore size (mm)	Stroke range (mm)	Without auto switch			With auto switch			(mm)		
		A	B	LS	A	B	LS	L	L ₁	LD
40	5 to 50	53.7	29.5	13.5	63.7	39.5	23.5	17	38.5	6.6
	75, 100	63.7	39.5	23.5						
50	10 to 50	56.7	30.5	7.5	66.7	40.5	17.5	18	43.5	9
	75, 100	66.7	40.5	17.5						
63	10 to 50	62.2	36	10	72.2	46	20	18	43.5	11
	75, 100	72.2	46	20						

Bore size (mm)	LG	LH	LX	LY	LZ	X	Y
40	4	33	64	64	78	11.2	7
50	5	39	79	78	95	14.7	8
63	5	46	95	91.5	113	16.2	9

Foot bracket material: Carbon steel
Surface treatment: Nickel plated

Compact foot: CQ2KLC/CDQ2KLC

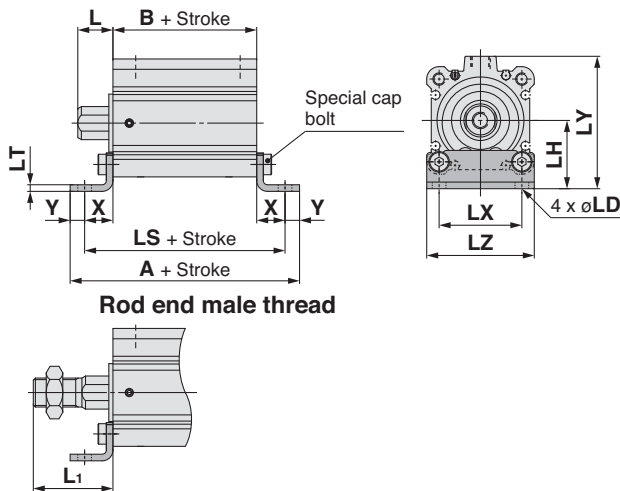

Compact Foot

Bore size (mm)	Stroke range (mm)	Without auto switch			With auto switch			(mm)		
		A	B	LS	A	B	LS	L	L ₁	LD
40	5 to 50	70.9	29.5	56.9	80.9	39.5	66.9	17	38.5	6.6
	75, 100	80.9	39.5	66.9						
50	10 to 50	79.9	30.5	63.9	89.9	40.5	73.9	18	43.5	9
	75, 100	89.9	40.5	73.9						
63	10 to 50	90.4	36	72.4	100.4	46	82.4	18	43.5	11
	75, 100	100.4	46	82.4						

Bore size (mm)	LH	LT	LX	LY	LZ	X	Y
40	33	3.2	40	64	52	13.7	7
50	39	3.2	50	78	64	16.7	8
63	46	3.2	60	91.5	77	18.2	9

Compact foot bracket material: Carbon steel
Surface treatment: Zinc chromated

Rod flange: CDQ2KF

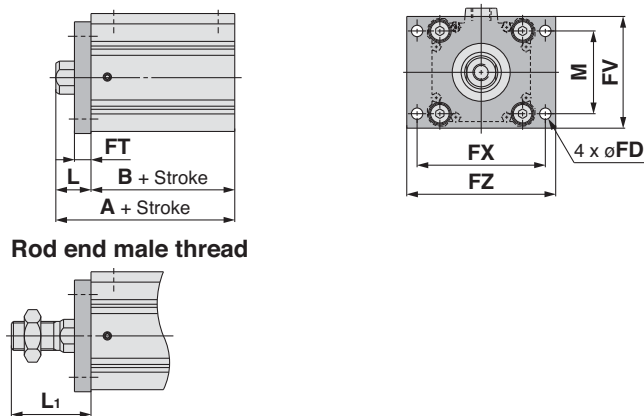

Rod Flange

Bore size (mm)	Stroke range (mm)	Without auto switch		With auto switch		FD	FT	FV	FX	FZ
		A	B	A	B					
40	5 to 50	46.5	29.5	56.5	39.5	5.5	8	54	62	72
	75, 100	56.5	39.5							
50	10 to 50	48.5	30.5	58.5	40.5	6.6	9	67	76	89
	75, 100	58.5	40.5							
63	10 to 50	54	36	64	46	9	9	80	92	108
	75, 100	64	46							

Bore size (mm)	L	L ₁	M
40	17	38.5	40
50	18	43.5	50
63	18	43.5	60

Flange bracket material: Carbon steel
Surface treatment: Nickel plated

Head flange: CDQ2KG

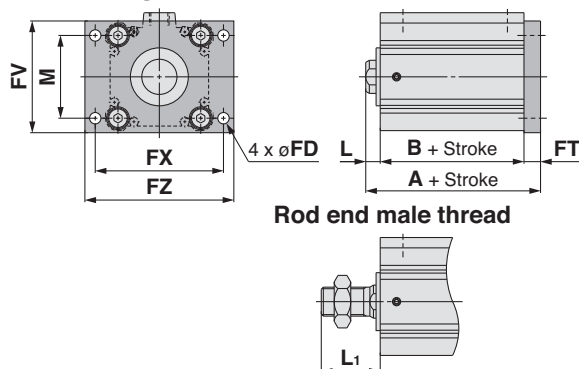

Head Flange

Bore size (mm)	Stroke range (mm)	Without auto switch		With auto switch	
		A	A	L	L ₁
40	5 to 50	44.5	54.5	7	28.5
	75, 100	54.5			
50	10 to 50	47.5	57.5	8	33.5
	75, 100	57.5			
63	10 to 50	53	63	8	33.5
	75, 100	63			

Flange bracket material: Carbon steel
Surface treatment: Nickel plated

(* The dimensions except A, L and L₁ are the same as those of the rod flange.)

Double clevis: **CDQ2KD**

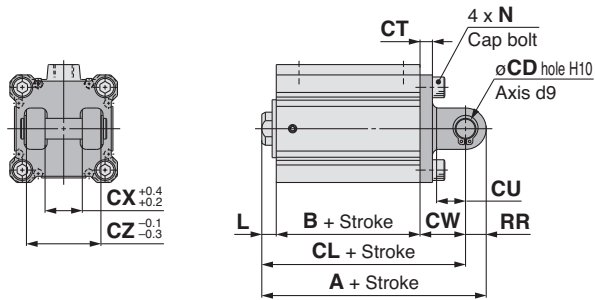

Rod end male thread

- * For details about the rod end nut and accessory brackets, refer to page 23.
- * Double clevis pin and retaining rings are included.

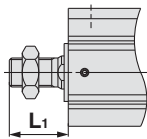

Double Clevis

(mm)

Bore size (mm)	Stroke range (mm)	Without auto switch			With auto switch			CD	CT	CU
		A	B	CL	A	B	CL			
40	5 to 50	68.5	29.5	58.5	78.5	39.5	68.5	10	6	14
	75, 100	78.5	39.5	68.5						
50	10 to 50	80.5	30.5	66.5	90.5	40.5	76.5	14	7	20
	75, 100	90.5	40.5	76.5						
63	10 to 50	88	36	74	98	46	84	14	8	20
	75, 100	98	46	84						

Bore size (mm)	CW	CX	CZ	L	L ₁	N	RR
40	22	18	36	7	28.5	M6 x 1.0	10
50	28	22	44	8	33.5	M8 x 1.25	14
63	30	22	44	8	33.5	M10 x 1.5	14

Double clevis bracket material: Cast iron
Surface treatment: Painted

Compact Cylinder: Non-rotating Rod Double Acting, Double Rod Series CQ2KW

ø12, ø16, ø20, ø25, ø32, ø40, ø50, ø63

How to Order

Without auto switch
ø12 to ø25

CQ2KW **B** **20** □ - **30** **D** □

Without auto switch
ø32 to ø63

CQ2KW **B** **32** □ - **30** **D** □ **Z**

With auto switch

CDQ2KW **B** **32** □ - **30** **D** □ **Z** - **M9BW** □

With auto switch
(Built-in magnet)

Mounting

B	Through-hole (Standard)	ø12 to ø63
A	Both ends tapped	ø40 to ø63
L	Foot	
LC	Compact foot	
F	Flange	

* Mounting brackets are shipped together (but not assembled).
* Cylinder mounting bolts are not included. Order them separately referring to "Mounting Bolt for C(D)Q2KWB" on pages 112 and 114.

Bore size

12	12 mm	32	32 mm
16	16 mm	40	40 mm
20	20 mm	50	50 mm
25	25 mm	63	63 mm

Port thread type

—	M thread	ø12 to ø25
	Rc	ø32 to ø63
TN	NPT	
TF	G	
F	Built-in one-touch fittings ^{Note)}	

Note) Bore sizes available with one-touch fittings are ø32 to ø63.

* For cylinders without auto switch, M threads are compatible only for ø32-5 mm stroke model.

Number of auto switches

—	2 pcs.
S	1 pc.
n	"n" pcs.

Auto switch

— Without auto switch

* Refer to the below table for applicable auto switches.

Auto switch mounting groove

Z	ø12 to ø25	2 surfaces
	ø32 to ø63	4 surfaces

Body option

—	Standard (Rod end female thread)
C	With rubber bumper (ø12 with auto switch only)
M	Rod end male thread

Cylinder stroke (mm)

Refer to the next page for standard strokes.

Action

D Double acting

Built-in Magnet Cylinder Model

If a built-in magnet cylinder without an auto switch is required, there is no need to enter the symbol for the auto switch.
(Example) CDQ2KWB32-30DZ

Refer to pages 1263 to 1371 in Best Pneumatics No. 2 for further information on auto switches.

Applicable Auto Switches

Refer to the individual catalogue (ES20-201) for the D-P3DW type.

Type	Special function	Electrical entry	Indicator light	Wiring (Output)	Load voltage		Auto switch model		Lead wire length (m)					Pre-wired connector	Applicable load			
					DC	AC	Perpendicular	In-line	0.5 (-)	1 (M)	3 (L)	5 (Z)	None (N)		Relay, PLC	—		
Solid state auto switch	Diagnostic indication (2-colour indication)	Grommet	Yes	3-wire (NPN)	24 V	5 V, 12 V	—	M9NV	M9N	●	●	●	○	—			○	IC circuit
				3-wire (PNP)				M9PV	M9P	●	●	●	○	—	○			
				2-wire				M9BV	M9B	●	●	●	○	—	○			
				3-wire (NPN)				M9NWV	M9NW	●	●	●	○	—	○			
				3-wire (PNP)				M9P WV	M9PW	●	●	●	○	—	○			
				2-wire				M9B WV	M9BW	●	●	●	○	—	○			
	Water resistant (2-colour indication)	Grommet	Yes	3-wire (NPN)	24 V	5 V, 12 V	—	M9NAV**	M9NA**	○	○	●	○	—	○	IC circuit	—	
				3-wire (PNP)				M9PAV**	M9PA**	○	○	●	○	—	○			
				2-wire				M9BAV**	M9BA**	○	○	●	○	—	○			
				2-wire (Non-polar)				—	P3DW	●	—	●	●	—	○			
Reed auto switch	—	Grommet	Yes	3-wire (NPN equivalent)	24 V	5 V	—	A96V	A96	●	—	●	—	—	—	—	IC circuit	—
				2-wire				A93V	A93	●	—	●	—	—	—	—	—	—
			No	2-wire	24 V	5 V, 12 V	100 V or less	A90V	A90	●	—	●	—	—	—	—	IC circuit	—

* Water resistant type auto switches can be mounted on the above models, but in such case SMC cannot guarantee water resistance. Consult with SMC regarding water resistant types with the above model numbers.

* Lead wire length symbols: 0.5 m — (Example) M9NW
1 m M (Example) M9NWM
3 m L (Example) M9NWL
5 m Z (Example) M9NWZ

* Solid state auto switches marked with "○" are produced upon receipt of order.
* The D-P3DW□ type is available from ø32 to ø63 only.

* There are other applicable auto switches other than the listed above. For details, refer to page 199.
* For details about auto switches with pre-wired connector, refer to pages 1328 and 1329 in Best Pneumatics No. 2.

Standard

Large Bore Size

Long Stroke

Non-rotating Rod

Axial Piping

Anti-lateral Load

With End Lock

Water Resistant

With Auto Switch

Auto Switch

Made to Order

Series CQ2KW



Symbol
Non-rotating rod,
Double acting

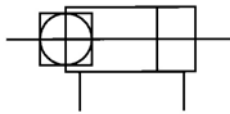

Made to Order
(For details, refer to pages 201 to 235.)

Symbol	Specifications
-XA□	Change of rod end shape
-XB10	Intermediate stroke (Exclusive body type)
-XC2(A)	Rod end length, 10 mm increased (For foot and flange bracket)
-X633	Intermediate stroke of double rod cylinder

* -X633: Intermediate stroke in 5 mm intervals only

Specifications

Bore size (mm)	12	16	20	25	32	40	50	63
Action	Double acting, Double rod							
Fluid	Air							
Proof pressure	1.5 MPa							
Maximum operating pressure	1.0 MPa							
Minimum operating pressure	0.07 MPa		0.05 MPa					
Ambient and fluid temperature	Without auto switch: -10 to 70°C (No freezing) With auto switch: -10 to 60°C (No freezing)							
Lubrication	Not required (Non-lube)							
Piston speed	50 to 500 mm/s							
Allowable kinetic energy (J)	0.022 0.043 Note 1)	0.038	0.055	0.09	0.15	0.26	0.46	0.77
Stroke length tolerance	+1.0 mm Note 2) 0							
Rod non-rotating accuracy	±2°		±1°			±0.8°		

* ø12 with auto switch: With rubber bumper (Standard)

Note 1) For cylinders with rubber bumper (ø12 with auto switch only)

Note 2) Stroke length tolerance does not include the amount of bumper change.

Standard Strokes

Bore size	Standard stroke (mm)
12, 16	5, 10, 15, 20, 25, 30
20, 25	5, 10, 15, 20, 25, 30, 35, 40, 45, 50
32, 40	5, 10, 15, 20, 25, 30, 35, 40, 45, 50, 75, 100
50, 63	10, 15, 20, 25, 30, 35, 40, 45, 50, 75, 100

Manufacture of Intermediate Strokes

Type	A spacer is installed in the standard stroke body.	
Part no.	Refer to "How to Order" for the standard model number. (P. 108)	
Description	Strokes in 5 mm intervals are available by installing a spacer in the standard stroke cylinder.	
Stroke range	Bore size	Stroke range
	32 to 63	55 to 95
Example	Part no.: CQ2KWB50-65DZ CQ2KWB50-75DZ with 10 mm width spacer inside The B dimension is 125.5 mm.	

Type

Bore size (mm)		12	16	20	25	32	40	50	63	
Pneumatic	Mounting	Through-hole (Standard)	●	●	●	●	●	●	●	
		Both ends tapped	—	—	—	—	●	●	●	
	Built-in magnet		●	●	●	●	●	●	●	
	Piping	Pipe thread	—	M5	M5	M5	M5	Note 1) Rc1/8	Rc1/4	Rc1/4
			TN	—	—	—	—	NPT1/8	NPT1/8	NPT1/4
		TF	—	—	—	—	G1/8	G1/8	G1/4	G1/4
Built-in one-touch fittings		—	—	—	—	ø6/4 Note 2)	ø6/4	ø8/6	ø8/6	
Rod end male thread		●	●	●	●	●	●	●	●	

Note 1) ø32 without auto switch: M5 is used for 5 mm strokepiping dimension.

Thus, do not enter a symbol for the port thread type.

Note 2) The dimensions of the ø32-5 mm stroke with built-in one-touch fittings are the same as those of the 10 mm stroke cylinder tube.

Refer to pages 193 to 199 for the specifications of cylinders with autoswitches.

- Auto switch proper mounting position (detection at stroke end) and its mounting height
- Minimum stroke for auto switch mounting
- Operating range
- Auto switch mounting brackets/Part no.

Compact Cylinder: Non-rotating Rod Double Acting, Double Rod *Series CQ2KW*

Retaining Ring Installation/Removal

⚠ Caution

- For installation and removal, use an appropriate pair of pliers (tool for installing a type C retaining ring).
- Even if a proper plier (tool for installing a type C retaining ring) is used, it is likely to inflict damage to a human body or peripheral equipment, as a retaining ring may be flown out of the tip of a plier (tool for installing a type C retaining ring). Be much careful with the popping of a retaining ring. Besides, be certain that a retaining ring is placed firmly into the groove of rod cover before supplying air at the time of installment.

Mounting

⚠ Warning

- Do not apply reverse torque to the piston rods sticking out from both sides of this cylinder at the same time. The torque makes connection threads inside loosen, which may cause an accident or malfunction. Install or remove loads while the piston rod width across flat is secured. Also, tighten by giving consideration to prevent the tightening torque from being applied to the non-rotating guide. Do not fix the other side of the piston rod width across flat and apply reverse torque.

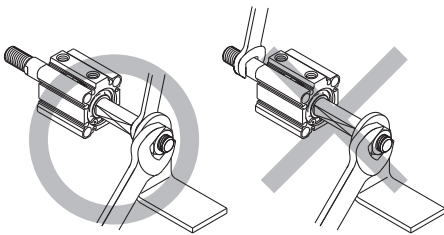

- Using a non-rotating rod cylinder

Avoid using the air cylinder in such a way that rotational torque would be applied to the piston rod. If rotational torque is applied, the non-rotating guide will deform, causing a loss of non-rotating accuracy.

Use the below table as a guide for the allowable rotational torque ranges.

Allowable rotational torque	ø12	ø16	ø20	ø25	ø32	ø40	ø50	ø63
N·m or less	0.04	0.15	0.20	0.25	0.44	0.44	0.44	0.44

Mounting Brackets/Part No.

Bore size (mm)	Foot ^{Note 1)}	Compact Foot ^{Note 1)}	Flange
40	CQ-L040	CQ-LC040	CQ-F040
50	CQ-L050	CQ-LC050	CQ-F050
63	CQ-L063	CQ-LC063	CQ-F063

Note 1) When ordering a foot and compact foot brackets, order 2 pieces per cylinder.

Note 2) Parts belonging to each bracket are as follows.
Foot, Compact foot, Flange: Body mounting bolts.

Theoretical Output

Bore size (mm)	Operating pressure (MPa)		
	0.3	0.5	0.7
12	25	42	59
16	45	75	106
20	71	118	165
25	113	189	264
32	181	302	422
40	317	528	739
50	495	825	1150
63	841	1400	1960

Weight

Weight

Bore size (mm)	Cylinder stroke (mm)											
	5	10	15	20	25	30	35	40	45	50	75	100
12	62	69	76	83	90	97	—	—	—	—	—	—
16	62	73	84	95	106	117	—	—	—	—	—	—
20	101	116	131	146	161	176	191	206	221	236	—	—
25	138	155	172	189	206	223	240	257	274	291	—	—
32	233	256	279	302	325	348	371	394	417	440	600	715
40	336	365	394	424	453	483	512	541	571	600	806	953
50	—	517	558	600	642	684	725	767	809	850	1142	1351
63	—	742	779	815	851	887	923	959	995	1032	1285	1465

Additional Weight

Bore size (mm)		12	16	20	25	32	40	50	63
Both ends tapped		—	—	—	—	—	6	6	19
Rod end male thread	Male thread	3	6	12	24	52	54	106	106
	Nut	2	4	8	16	34	34	64	64
Built-in one-touch fittings		—	—	—	—	12	12	21	21
Foot		—	—	—	—	—	154	243	317
Compact foot (Including mounting bolts)		—	—	—	—	—	114	177	241
Flange		—	—	—	—	—	214	373	559

Calculation: (Example) **CQ2KWA40-20DMZ**

- Basic weight: CQ2KWB40-20DZ 424 g
 - Additional weight: Both ends tapped 6 g
 - Rod end male thread 88 g
- 518 g

Standard

Large Bore Size

Long Stroke

Non-rotating Rod

Axial Piping

Anti-lateral Load

With End Lock

Water Resistant

With Auto Switch

Auto Switch

Made to Order

Series CQ2KW

Construction

Standard (ø12 to ø32)

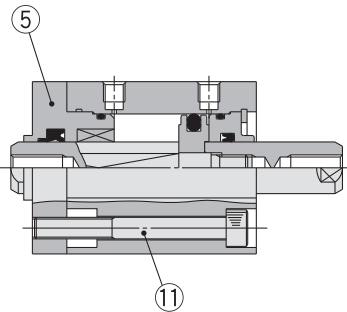

Standard (ø40 to ø63)

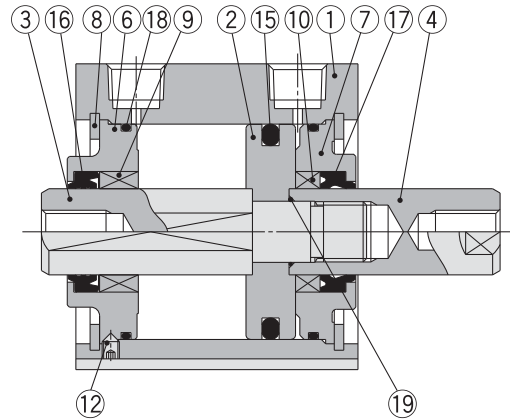

Built-in one-touch fittings

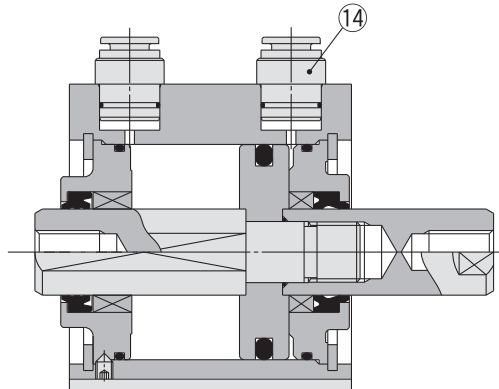

Rod end male thread

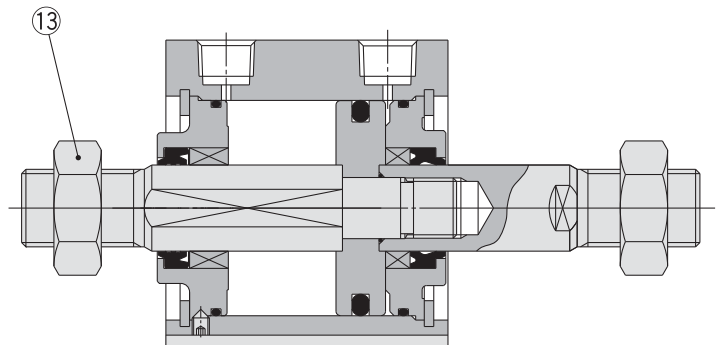

Component Parts

No.	Description	Material	Note
1	Cylinder tube	Aluminum alloy	Hard anodised
2	Piston	Aluminum alloy	Chromated
3	Piston rod A	Stainless steel	ø12 to ø25
		Carbon steel	ø32 to ø63, Hard chrome plated
4	Piston rod B	Stainless steel	ø12 to ø25
		Carbon steel	ø32 to ø63, Hard chrome plated
5	Rod cover	Brass	ø12, Electroless nickel plated
		Aluminum alloy	ø16 to ø32, Anodised
6	Collar for non-rotating	Aluminum alloy	ø40 to ø63, Anodised
		Aluminum alloy	ø12 to ø40, Anodised
7	Collar	Aluminum alloy	ø12 to ø40, Anodised
		Aluminum alloy casted	ø50 to ø63, Chromated, Painted
8	Retaining ring	Carbon tool steel	Phosphate coated
9	Bushing for non-rotating	Oil-impregnated sintered alloy	ø16 to ø63
10	Bushing	Bearing alloy	ø50, ø63
11	Hexagon socket head cap screw	Alloy steel	ø12 to ø32, Nickel plated
12	Hexagon socket head set screw	Alloy steel	ø40 to ø63, Nickel plated
13	Rod end nut	Carbon steel	Nickel plated
14	One-touch fitting	—	ø32 to ø63
15	Piston seal	NBR	
16	Rod seal for non-rotating	NBR	
17	Rod seal	NBR	
18	Gasket	NBR	
19	Piston gasket	NBR	ø32 to ø63

Replacement Parts/Seal Kit

Bore size (mm)	Kit no.	Contents
12	CQ2KWB12-PS	Kits include items 15, 16, 17, 18 from the table.
16	CQ2KWB16-PS	
20	CQ2KWB20-PS	
25	CQ2KWB25-PS	
32	CQ2KWB32-PS	
40	CQ2KWB40-PS	
50	CQ2KWB50-PS	
63	CQ2KWB63-PS	

* Seal kit includes 15, 16, 17, 18. Order the seal kit based on each bore size.

* Since the seal kit does not include a grease pack, order it separately.

Grease pack part no.: GR-S-010 (10 g)

Mounting Bolt for CQ2KWB/Without Auto Switch

Mounting method: Mounting bolt for through-hole mounting of the CQ2KWB is available as an option. Refer to the following for ordering procedures. Order the actual number of bolts that will be used.

Example) CQ-M3 x 40L 2 pcs.

Material: Chromium molybdenum steel
Surface treatment: Zinc chromated

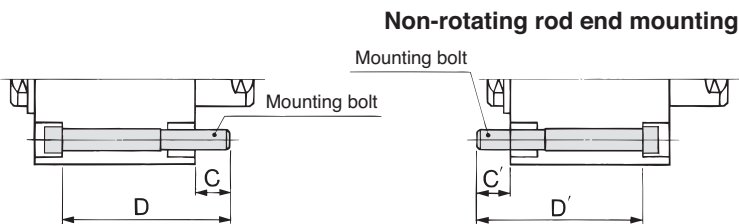

Cylinder model	C	D	Mounting bolt part no.	C'	D'	Mounting bolt part no.
CQ2KWB12-5D	8.3	40	CQ-M3 x 40L	8.3	40	CQ-M3 x 40L
-10D		45	x 45L		45	x 45L
-15D		50	x 50L		50	x 50L
-20D		55	x 55L		55	x 55L
-25D		60	x 60L		60	x 60L
-30D		65	x 65L		65	x 65L
CQ2KWB16-5D	7.5	40	CQ-M3 x 40L	7.5	40	CQ-M3 x 40L
-10D		45	x 45L		45	x 45L
-15D		50	x 50L		50	x 50L
-20D		55	x 55L		55	x 55L
-25D		60	x 60L		60	x 60L
-30D		65	x 65L		65	x 65L
CQ2KWB20-5D	6.5	40	CQ-M5 x 40L	8	40	CQ-M5 x 40L
-10D		45	x 45L		45	x 45L
-15D		50	x 50L		50	x 50L
-20D		55	x 55L		55	x 55L
-25D		60	x 60L		60	x 60L
-30D		65	x 65L		65	x 65L
-35D		70	x 70L		70	x 70L
-40D		75	x 75L		75	x 75L
-45D		80	x 80L		80	x 80L
-50D		85	x 85L		85	x 85L
CQ2KWB25-5D	8.5	45	CQ-M5 x 45L	10	45	CQ-M5 x 45L
-10D		50	x 50L		50	x 50L
-15D		55	x 55L		55	x 55L
-20D		60	x 60L		60	x 60L
-25D		65	x 65L		65	x 65L
-30D		70	x 70L		70	x 70L
-35D		75	x 75L		75	x 75L
-40D		80	x 80L		80	x 80L
-45D		85	x 85L		85	x 85L
-50D		90	x 90L		90	x 90L
CQ2KWB32-5DZ	11	50	CQ-M5 x 50L	7.5	45	CQ-M5 x 45L
-10DZ		55	x 55L		50	x 50L
-15DZ		60	x 60L		55	x 55L
-20DZ		65	x 65L		60	x 60L
-25DZ		70	x 70L		65	x 65L
-30DZ		75	x 75L		70	x 70L
-35DZ		80	x 80L		75	x 75L
-40DZ		85	x 85L		80	x 80L
-45DZ		90	x 90L		85	x 85L
-50DZ		95	x 95L		90	x 90L
-75DZ	130	x 130L	125	x 125L		
-100DZ	155	x 155L	150	x 150L		

Cylinder model	C	D	Mounting bolt part no.
CQ2KWB40-5DZ	7	45	CQ-M5 x 45L
-10DZ		50	x 50L
-15DZ		55	x 55L
-20DZ		60	x 60L
-25DZ		65	x 65L
-30DZ		70	x 70L
-35DZ		75	x 75L
-40DZ		80	x 80L
-45DZ		85	x 85L
-50DZ		90	x 90L
-75DZ	125	x 125L	
-100DZ	150	x 150L	
CQ2KWB50-10DZ	12.5	55	CQ-M6 x 55L
-15DZ		60	x 60L
-20DZ		65	x 65L
-25DZ		70	x 70L
-30DZ		75	x 75L
-35DZ		80	x 80L
-40DZ		85	x 85L
-45DZ		90	x 90L
-50DZ		95	x 95L
-75DZ		130	x 130L
-100DZ	155	x 155L	
CQ2KWB63-10DZ	13.5	55	CQ-M8 x 55L
-15DZ		60	x 60L
-20DZ		65	x 65L
-25DZ		70	x 70L
-30DZ		75	x 75L
-35DZ		80	x 80L
-40DZ		85	x 85L
-45DZ		90	x 90L
-50DZ		95	x 95L
-75DZ		130	x 130L
-100DZ	155	x 155L	

* ø40 to ø63: The C' and D' dimensions are the same as those of C and D.

Copper and Fluorine-free Series (For CRT Manufacturing Process)

20 — CQ2KWB **Bore size** — **Stroke** D(M)(Z)
 ↳ ø16, ø20, ø25, ø32, ø40, ø50, ø63

• Copper and fluorine-free series

For preventing the influence of copper ions or halogen ions during CRT manufacturing processes, copper and fluorine materials are not used in the component parts.

Specifications

Bore size (mm)	16	20	25	32	40	50	63
Action	Double acting, Double rod						
Proof pressure	1.5 MPa						
Max. operating pressure	1.0 MPa						
Rubber bumper	None						
Piping	Pipe thread						
Piston speed	50 to 500 mm/s						
Mounting	Through-hole						
Auto switch	Mountable						

Standard

Large Bore Size

Long Stroke

Non-rotating Rod

Axial Piping

Anti-lateral Load

With End Lock

Water Resistant

With Auto Switch

Auto Switch

Made to Order

Non-rotating Rod: Double Acting, Double Rod Series **CDQ2KW** With Auto Switch



Refer to the below pages for further information on auto switches.

Auto switch proper mounting position and its mounting height	P.193 to 199
Minimum stroke for auto switch mounting	
Operating range	
Auto switch mounting brackets/Part no.	

Weight

Weight

Bore size (mm)	Cylinder stroke (mm)											
	5	10	15	20	25	30	35	40	45	50	75	100
12	76	83	90	98	105	113	—	—	—	—	—	—
16	89	99	109	118	128	138	—	—	—	—	—	—
20	148	164	179	194	210	225	240	256	271	286	—	—
25	213	228	244	259	275	291	306	322	337	353	—	—
32	259	282	305	328	351	374	397	420	443	466	580	695
40	441	471	500	530	559	588	618	647	677	706	853	1000
50	—	642	684	726	767	809	851	892	934	976	1184	1393
63	—	871	907	943	979	1015	1051	1088	1124	1160	1341	1521

Additional Weight

Bore size (mm)	12	16	20	25	32	40	50	63
Both ends tapped	—	—	—	—	—	6	6	19
Rod end male thread	Male thread	3	6	12	24	52	54	106
	Nut	2	4	8	16	34	34	64
Built-in one-touch fittings	—	—	—	—	12	12	21	21
Foot (Including mounting bolts)	—	—	—	—	—	154	243	317
Compact foot (Including mounting bolts)	—	—	—	—	—	114	177	241
Flange (Including mounting bolts)	—	—	—	—	—	214	373	559

Calculation: (Example) **CDQ2KWA40-20DMZ**

- Basic weight: CDQ2KWB40-20DZ..... 530 g
- Additional weight: Both ends tapped 6 g
- Rod end male thread 88 g
- 624 g

Add each weight of auto switches when auto switches are mounted.

Construction

ø12 to ø25

ø32

ø40 to ø63

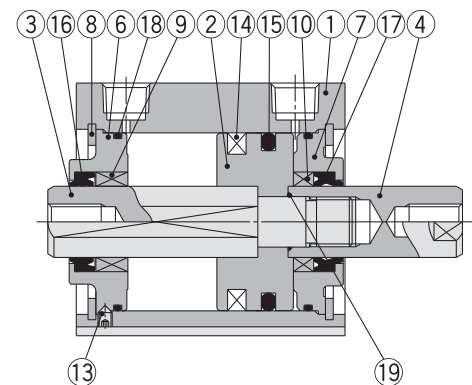
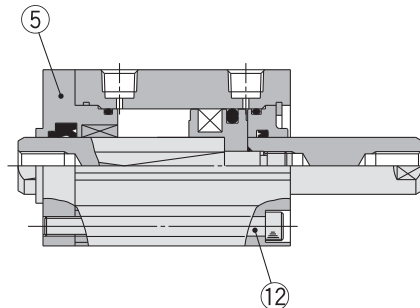
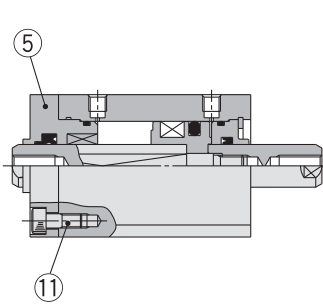

Component Parts

No.	Description	Material	Note
1	Cylinder tube	Aluminum alloy	Hard anodised
2	Piston	Aluminum alloy	Chromated
3	Piston rod A	Stainless steel	ø12 to ø25
		Carbon steel	ø32 to ø63, Hard chrome plated
4	Piston rod B	Stainless steel	ø12 to ø25
		Carbon steel	ø32 to ø63, Hard chrome plated
5	Rod cover	Brass	ø12, Electroless nickel plated
		Aluminum alloy	ø16 to ø32, Anodised
6	Collar for non-rotating	Aluminum alloy	ø40 to ø63, Anodised
7	Collar	Aluminum alloy	ø12 to ø40, Anodised
		Aluminum alloy casted	ø50 to ø63, Chromated, Painted
8	Retaining ring	Carbon tool steel	Phosphate coated
9	Bushing for non-rotating	Oil-impregnated sintered alloy	ø16 to ø63
10	Bushing	Bearing alloy	ø50, ø63
11	Hexagon socket head cap screw	Alloy steel	ø12 to ø25, Nickel plated
12	Hexagon socket head cap screw	Alloy steel	ø32, Nickel plated
13	Hexagon socket head set screw	Alloy steel	ø40 to ø63, Nickel plated
14	Magnet	—	—

No.	Description	Material	Note
15	Piston seal	NBR	
16	Rod seal for non-rotating	NBR	
17	Rod seal	NBR	
18	Gasket	NBR	
19	Piston gasket	NBR	ø32 to ø63

Replacement Parts/Seal Kit

Bore size (mm)	Kit no.	Contents
12	CQ2KWB12-PS	Kits include items 15, 16, 17, 18 from the table.
16	CQ2KWB16-PS	
20	CQ2KWB20-PS	
25	CQ2KWB25-PS	
32	CQ2KWB32-PS	
40	CQ2KWB40-PS	
50	CQ2KWB50-PS	
63	CQ2KWB63-PS	

* Seal kit includes 15, 16, 17, 18. Order the seal kit based on each bore size.

* Since the seal kit does not include a grease pack, order it separately.

Grease pack part no.: GR-S-010 (10 g)

Mounting Bolt for CDQ2KWB/With Auto Switch

Mounting method: Mounting bolt for through-hole mounting of the CDQ2KWB is available as an option. Refer to the following for ordering procedures. Order the actual number of bolts that will be used.

Example) CQ-M3 x 40L 2 pcs.

Material: Chromium molybdenum steel
Surface treatment: Zinc chromated

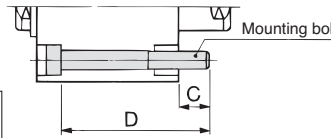

Non-rotating rod end mounting

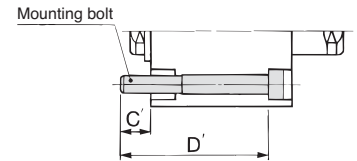

Cylinder model	C	D	Mounting bolt part no.	C'	D'	Mounting bolt part no.
CDQ2KWB12-5DCZ	6.1	40	CQ-M3 x 40L	6.1	45	CQ-M3 x 45L
-10DCZ		45	x 45L		50	x 50L
-15DCZ		50	x 50L		55	x 55L
-20DCZ		55	x 55L		60	x 60L
-25DCZ		60	x 60L		65	x 65L
-30DCZ		65	x 65L		70	x 70L
CDQ2KWB16-5DZ	7.5	45	CQ-M3 x 45L	7.5	50	CQ-M3 x 50L
-10DZ		50	x 50L		55	x 55L
-15DZ		55	x 55L		60	x 60L
-20DZ		60	x 60L		65	x 65L
-25DZ		65	x 65L		70	x 70L
-30DZ		70	x 70L		75	x 75L
CDQ2KWB20-5DZ	9	45	CQ-M5 x 45L	11	55	CQ-M5 x 55L
-10DZ		50	x 50L		60	x 60L
-15DZ		55	x 55L		65	x 65L
-20DZ		60	x 60L		70	x 70L
-25DZ		65	x 65L		75	x 75L
-30DZ		70	x 70L		80	x 80L
-35DZ		75	x 75L		85	x 85L
-40DZ		80	x 80L		90	x 90L
-45DZ		85	x 85L		95	x 95L
-50DZ		90	x 90L		100	x 100L
CDQ2KWB25-5DZ	8	45	CQ-M5 x 45L	10	55	CQ-M5 x 55L
-10DZ		50	x 50L		60	x 60L
-15DZ		55	x 55L		65	x 65L
-20DZ		60	x 60L		70	x 70L
-25DZ		65	x 65L		75	x 75L
-30DZ		70	x 70L		80	x 80L
-35DZ		75	x 75L		85	x 85L
-40DZ		80	x 80L		90	x 90L
-45DZ		85	x 85L		95	x 95L
-50DZ		90	x 90L		100	x 100L
CDQ2KWB32-5DZ	11	60	CQ-M5 x 60L	7.5	55	CQ-M5 x 55L
-10DZ		65	x 65L		60	x 60L
-15DZ		70	x 70L		65	x 65L
-20DZ		75	x 75L		70	x 70L
-25DZ		80	x 80L		75	x 75L
-30DZ		85	x 85L		80	x 80L
-35DZ		90	x 90L		85	x 85L
-40DZ		95	x 95L		90	x 90L
-45DZ		100	x 100L		95	x 95L
-50DZ		105	x 105L		100	x 100L
-75DZ	130	x 130L	125	x 125L		
-100DZ	155	x 155L	150	x 150L		

Cylinder model	C	D	Mounting bolt part no.	
CDQ2KWB40-5DZ	7	55	CQ-M5 x 55L	
-10DZ		60	x 60L	
-15DZ		65	x 65L	
-20DZ		70	x 70L	
-25DZ		75	x 75L	
-30DZ		80	x 80L	
-35DZ		85	x 85L	
-40DZ		90	x 90L	
-45DZ		95	x 95L	
-50DZ		100	x 100L	
-75DZ	12.5	125	x 125L	
-100DZ		150	x 150L	
CDQ2KWB50-10DZ		13.5	65	CQ-M6 x 65L
-15DZ			70	x 70L
-20DZ			75	x 75L
-25DZ			80	x 80L
-30DZ			85	x 85L
-35DZ			90	x 90L
-40DZ			95	x 95L
-45DZ			100	x 100L
-50DZ	105		x 105L	
-75DZ	130		x 130L	
-100DZ	155	x 155L		
CDQ2KWB63-10DZ	13.5	65	CQ-M8 x 65L	
-15DZ		70	x 70L	
-20DZ		75	x 75L	
-25DZ		80	x 80L	
-30DZ		85	x 85L	
-35DZ		90	x 90L	
-40DZ		95	x 95L	
-45DZ		100	x 100L	
-50DZ		105	x 105L	
-75DZ		130	x 130L	
-100DZ	155	x 155L		

* ø40 to ø63: The C' and D' dimensions are the same as those of C and D.

- Standard
- Large Bore Size
- Long Stroke
- Non-rotating Rod
- Axial Piping
- Anti-lateral Load
- With End Lock
- Water Resistant
- With Auto Switch
- Auto Switch
- Made to Order

Series CQ2KW

Dimensions

Ø12 to Ø32/Without Auto Switch

Standard (Through-hole): CQ2KWB

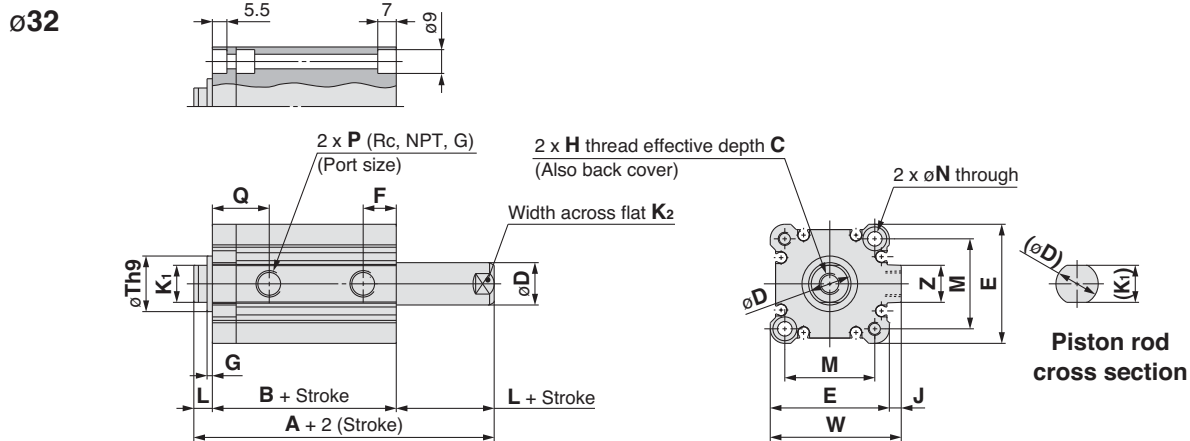
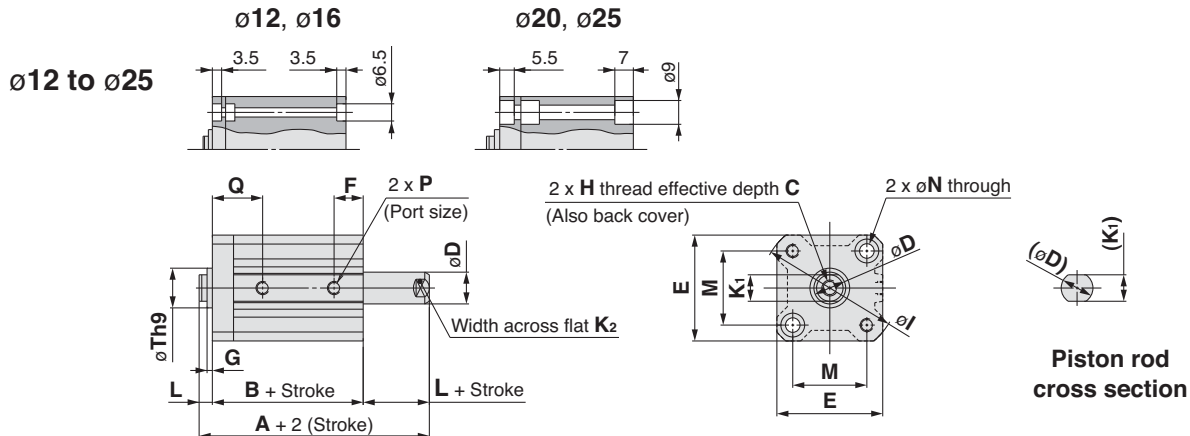

Rod end male thread

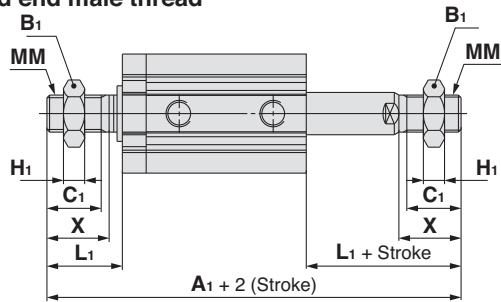

Rod End Male Thread (mm)

Bore size (mm)	Stroke range (mm)	A ₁	B ₁	C ₁	H ₁
12	5 to 30	58.2	8	9	4
16	5 to 30	62	10	10	5
20	5 to 50	71	13	12	5
25	5 to 50	82	17	15	6
32	5 to 50	96.5	22	20.5	8
	75, 100	106.5			

Bore size (mm)	L ₁	MM	X
12	14	M5 x 0.8	10.5
16	15.5	M6 x 1.0	12
20	18.5	M8 x 1.25	14
25	22.5	M10 x 1.25	17.5
32	28.5	M14 x 1.5	23.5

Built-in one-touch fittings: Ø32

Built-in one-touch fittings

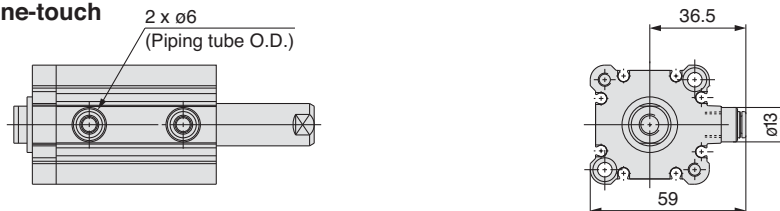

* The dimensions of Ø32-5 mm stroke with built-in one-touch fittings are the same as those of the 10 mm stroke cylinder tube. (mm)

Standard

Bore size (mm)	Stroke range (mm)	A	B	C	D	E	F	G	H	I	J	K ₁	K ₂	L	M	N	P	Q	Th9	W	Z
12	5 to 30	37.2	30.2	6	6	25	10	1.5	M3 x 0.5	32	—	5.2	5	3.5	15.5	3.5	M5	15	15 ⁰ _{-0.043}	—	—
16	5 to 30	38	31	8	8	29	10	1.5	M4 x 0.7	38	—	6	6	3.5	20	3.5	M5	15	20 ⁰ _{-0.052}	—	—
20	5 to 50	43	34	7	10	36	8	2	M5 x 0.8	47	—	8	8	4.5	25.5	5.5	M5	16	13 ⁰ _{-0.043}	—	—
25	5 to 50	47	37	12	12	40	9	2	M6 x 1.0	52	—	10	10	5	28	5.5	M5	17	15 ⁰ _{-0.043}	—	—
32	5	53.5	39.5	13	16	45	10	2	M8 x 1.25	—	4.5	14	14	7	34	5.5	M5	19	21 ⁰ _{-0.052}	49.5	14
	10 to 50																				
	75, 100	63.5	49.5																		

* For details about the rod end nut and accessory brackets, refer to page 23.

Note) The positions of piston rod's width across flats (K₂) are not constant.

Series CQ2KW

Dimensions

Ø40 to Ø63/With Auto Switch

(In the case of without auto switches, the A, B dimensions will be only changed. Refer to the dimension table.)

Both ends tapped: CQ2KWA/CDQ2KWA

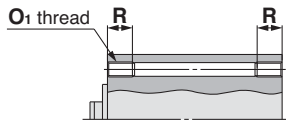

Both Ends Tapped

Bore size (mm)	O ₁	R
40	M6 x 1.0	10
50	M8 x 1.25	14
63	M10 x 1.5	18

Standard (Through-hole): CQ2KWB/CDQ2KWB

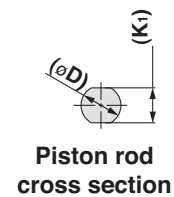
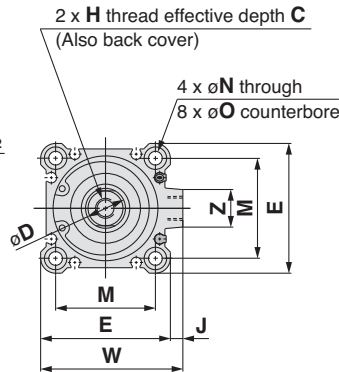
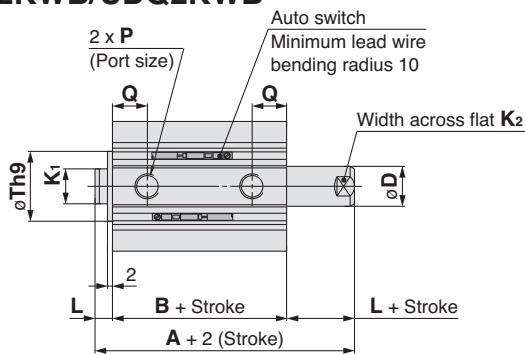

Piston rod cross section

Rod end male thread

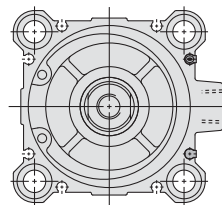

Cylinder tube form ø63

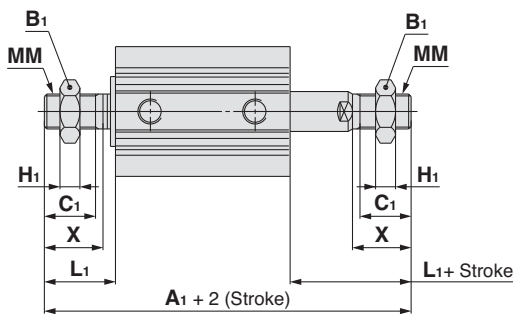

Rod End Male Thread

Bore size (mm)	Without auto switch		With auto switch		B ₁	C ₁	H ₁	L ₁	MM	X
	A ₁	A ₁	A ₁	A ₁						
40	97	107	22	20.5	8	28.5	M14 x 1.5	23.5		
50	107.5	117.5	27	26	11	33.5	M18 x 1.5	28.5		
63	109	119	27	26	11	33.5	M18 x 1.5	28.5		

Built-in one-touch fittings: ø40 to ø63

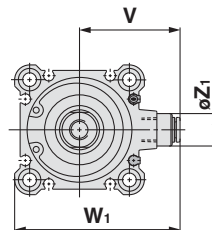
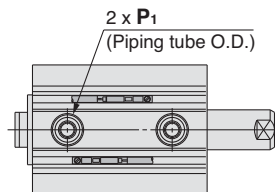

Built-in One-touch Fittings

Bore size (mm)	Z ₁	P ₁	V	W ₁
40	13	6	40.5	66.5
50	16	8	50	82
63	16	8	56.5	95

Standard For auto switch proper mounting position and its mounting height, refer to pages 193 to 199.

Bore size (mm)	Stroke range (mm)	Without auto switch		With auto switch		C	D	E	H	J	K ₁	K ₂	L	M	N	O	P	Q	Th9	W	Z
		A	B	A	B																
40	5 to 50	54	40	64	50	13	16	52	M8 x 1.25	5	14	14	7	40	5.5	9 depth 7	1/8	12.5	28 ⁰ _{-0.052}	57	15
	75, 100	64	50																		
50	10 to 50	56.5	40.5	66.5	50.5	15	20	64	M10 x 1.5	7	18	17	8	50	6.6	11 depth 8	1/4	14	35 ⁰ _{-0.062}	71	19
	75, 100	66.5	50.5																		
63	10 to 50	58	42	68	52	15	20	77	M10 x 1.5	7	18	17	8	60	9	14 depth 10.5	1/4	15.5	35 ⁰ _{-0.062}	84	19
	75, 100	68	52																		

* For details about the rod end nut and accessory brackets, refer to page 23.
Note) The positions of piston rod's width across flats (K₂) are not constant.

Compact Cylinder: Non-rotating Rod Double Acting, Double Rod *Series CQ2KW*

Foot: CQ2KWL/CDQ2KWL

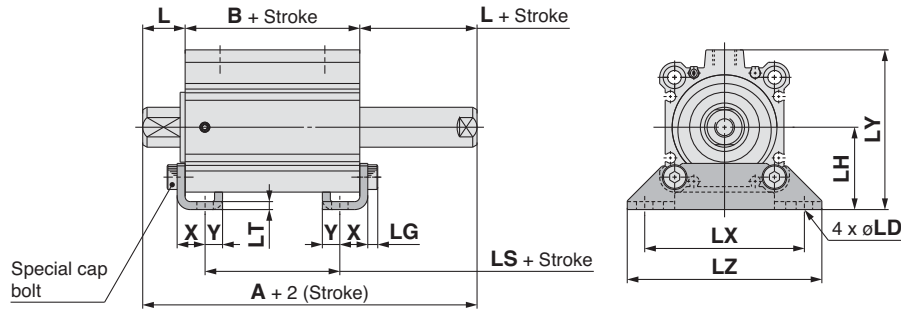

Rod end male thread

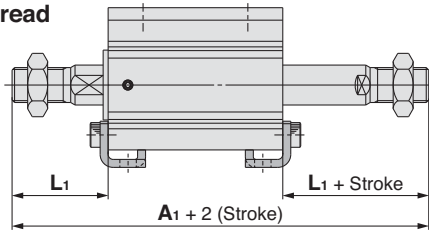

Rod End Male Thread (mm)

Bore size (mm)	Without auto switch		L ₁
	A ₁	A ₁	
40	117	127	38.5
50	127.5	137.5	43.5
63	129	139	43.5

Foot

Bore size (mm)	Stroke range (mm)	Without auto switch			With auto switch			L	LD	LG	LH	LT	LX	LY	LZ	X	Y
		A	B	LS	A	B	LS										
40	5 to 50	74	40	24	84	50	34	17	6.6	4	33	3.2	64	68	78	11.2	7
	75, 100	84	50	34													
50	10 to 50	76.5	40.5	17.5	86.5	50.5	27.5	18	9	5	39	3.2	79	78	95	14.7	8
	75, 100	86.5	50.5	27.5													
63	10 to 50	78	42	16	88	52	26	18	11	5	46	3.2	95	91.5	113	16.2	8
	75, 100	88	52	26													

Foot bracket material: Carbon steel
Surface treatment: Nickel plated

Compact foot: CQ2KWLC/CDQ2KWLC

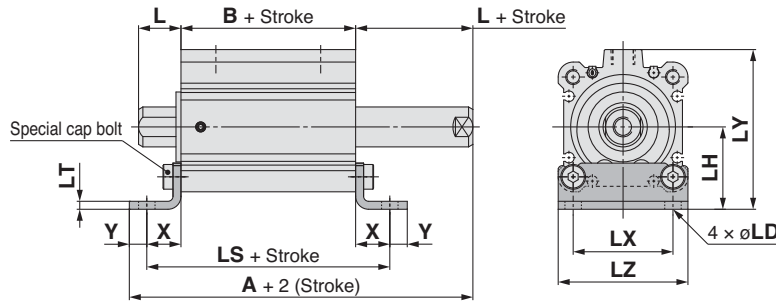

Rod end male thread

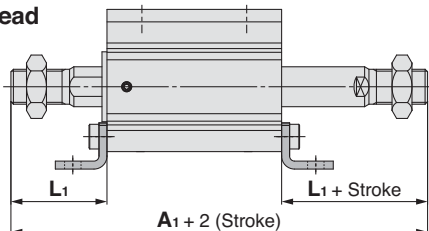

Rod End Male Thread (mm)

Bore size (mm)	Stroke range (mm)	A ₁		L ₁
		Without auto switch	With auto switch	
40	5 to 50	117	127	38.5
	75, 100	127		
50	10 to 50	127.5	137.5	43.5
	75, 100	137.5		
63	10 to 50	129	139	43.5
	75, 100	139		

Compact Foot

Bore size (mm)	Stroke range (mm)	Without auto switch			With auto switch			L	LD	LH	LT	LX	LY	LZ	X	Y
		A	B	LS	A	B	LS									
40	5 to 50	81.4	40	67.4	91.4	50	77.4	17	6.6	33	3.2	40	64	52	13.7	7
	75, 100	91.4	50	77.4												
50	10 to 50	89.9	40.5	73.9	99.9	50.5	83.9	18	9	39	3.2	50	78	64	16.7	8
	75, 100	99.9	50.5	83.9												
63	10 to 50	96.4	42	78.4	106.4	52	88.4	18	11	46	3.2	60	91.5	77	18.2	9
	75, 100	106.4	52	88.4												

* For details about the rod end nut and accessory brackets, refer to page 23.

Compact foot bracket material: Carbon steel
Surface treatment: Zinc chromated

Standard

Large Bore Size

Long Stroke

Non-rotating Rod

Axial Piping

Anti-lateral Load

With End Lock

Water Resistant

With Auto Switch

Auto Switch

Made to Order

Series CQ2KW

Flange: CQ2KWF/CDQ2KWF

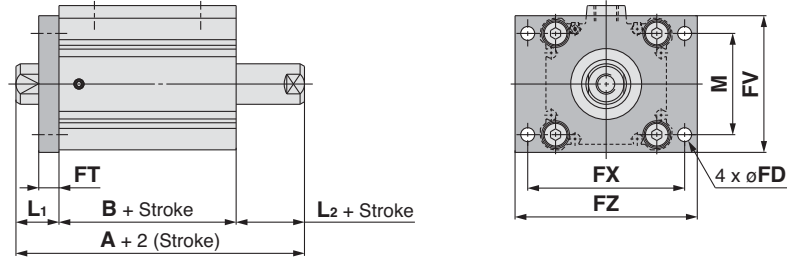

Rod end male thread

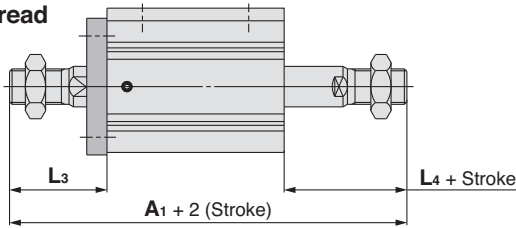

Rod End Male Thread

(mm)

Bore size (mm)	Without auto switch	With auto switch	L ₃	L ₄
	A ₁	A ₁		
40	107	117	38.5	28.5
50	117.5	127.5	43.5	33.5
63	119	129	43.5	33.5

Flange For auto switch proper mounting position and its mounting height, refer to pages 169 to 175. (mm)

Bore size (mm)	Stroke range (mm)	Without auto switch		With auto switch		FD	FT	FV	FX	FZ	L ₁	L ₂	M
		A	B	A	B								
40	5 to 50	64	40	74	50	5.5	8	54	62	72	17	7	40
	75, 100	74	50										
50	10 to 50	66.5	40.5	76.5	50.5	6.6	9	67	76	89	18	8	50
	75, 100	76.5	50.5										
63	10 to 50	68	42	78	52	9	9	80	92	108	18	8	60
	75, 100	78	52										

* For details about the rod end nut and accessory brackets, refer to page 23.

Flange bracket material: Carbon steel
Surface treatment: Nickel plated

Compact Cylinder: Axial Piping Double Acting, Single Rod Series CQP2

ø12, ø16, ø20, ø25, ø32, ø40, ø50, ø63, ø80, ø100

How to Order

Without auto switch

CQP2B [] 50 [] - 30 D [] - []

With auto switch

CDQP2B [] 50 [] - 30 D [] - M9BW [] - []

With auto switch
(Built-in magnet)

Axial piping

Mounting

B Through-hole

* Cylinder mounting bolts are not included.
Order them separately referring to "Mounting Bolt for C(D)QP2B" on pages 124 and 127.

Type	
—	Pneumatic
H	Air-hydro ^{Note 1)}

Note 1) Bore sizes available for air-hydro type are ø20 to ø100.

Bore size

12	12 mm
16	16 mm
20	20 mm
25	25 mm
32	32 mm
40	40 mm
50	50 mm
63	63 mm
80	80 mm
100	100 mm

Built-in Magnet Cylinder Model

If a built-in magnet cylinder without an auto switch is required, there is no need to enter the symbol for the auto switch.
(Example) CDQP2B32-30D

Port thread type

—	M thread	ø12 to ø25
	Rc	
TN	NPT	ø32 to ø100
TF	G	

Made to Order

Refer to the next page for details.

Number of auto switches

—	2 pcs.
S	1 pc.
n	"n" pcs.

Auto switch

— Without auto switch

* Refer to the below table for applicable auto switches.

Body option

—	Standard (Rod end female thread)
C	With rubber bumper ^{Note 2)}
M	Rod end male thread

* Combination of body option ("CM") is available.
Note 2) Air-hydro type with rubber bumper is not available.

Action

D Double acting

Cylinder stroke (mm)

Refer to the next page for standard strokes.

Applicable Auto Switches/Refer to pages 1263 to 1371 in Best Pneumatics No. 2 for further information on auto switches.

Type	Special function	Electrical entry	Indicator light	Wiring (Output)	Load voltage		Auto switch model		Lead wire length (m)					Pre-wired connector	Applicable load		
					DC	AC	Perpendicular	In-line	0.5 (-)	1 (M)	3 (L)	5 (Z)	None (N)				
Solid state auto switch	—	Grommet		3-wire (NPN)	24 V	5 V, 12 V	—	M9NV	M9N	●	●	●	○	—	○	IC circuit	
				3-wire (PNP)				M9PV	M9P	●	●	●	○	—	○		
	Diagnostic indication (2-colour indication)	Connector	Yes	2-wire	24 V	5 V, 12 V	—	M9BV	M9B	●	●	●	○	—	○	—	
				3-wire (NPN)				J79C	—	●	—	●	●	—	—		
	Water resistant (2-colour indication)	Grommet		3-wire (NPN)	24 V	5 V, 12 V	—	M9NVV	M9NV	●	●	●	○	—	○	IC circuit	
				3-wire (PNP)				M9PVV	M9PV	●	●	●	○	—	○		
	With diagnostic output (2-colour indication)	Grommet		2-wire	24 V	12 V	—	M9BWW	M9BW	●	●	●	○	—	○	—	
				3-wire (NPN)				M9NAV**	M9NA**	○	○	●	○	—	○		
	Magnetic field resistant (2-colour indication)	Grommet		3-wire (PNP)	24 V	5 V, 12 V	—	M9PAV**	M9PA**	○	○	●	○	—	○	IC circuit	
				2-wire				M9BAV**	M9BA**	○	○	●	○	—	○		
Reed auto switch	—	Grommet	Yes	3-wire (NPN equivalent)	24 V	5 V	—	A96V	A96	●	—	●	—	—	IC circuit		
				2-wire				A72	A72H	●	—	●	—	—		—	
Diagnostic indication (2-colour indication)	Grommet		No	2-wire	24 V	5 V, 12 V	100 V or less	A93V	A93	●	—	●	—	—	IC circuit		
								A90V	A90	●	—	●	—	—		—	
								A73C	—	●	—	●	●	●		—	—
								A80C	—	●	—	●	●	●		—	—
Magnetic field resistant (2-colour indication)	Connector	No	Yes	2-wire	24 V	5 V, 12 V	24 V or less	A79W	—	●	—	●	—	—	IC circuit		
								—	—	●	—	●	—	—		—	

* Water resistant type auto switches can be mounted on the above models, but in such case SMC cannot guarantee water resistance. Consult with SMC regarding water resistant types with the above model numbers.

* Lead wire length symbols: 0.5 m — (Example) M9NV
1 m M (Example) M9NVW
3 m L (Example) M9NVWL
5 m Z (Example) M9NVWZ
None N (Example) J79CN

* Solid state auto switches marked with "○" are produced upon receipt of order.

* The D-P4DWL type is available from ø40 to ø100 only.

* Only for the D-P4DWL type, an auto switch is assembled and shipped with the cylinder.

* There are other applicable auto switches other than the listed above. For details, refer to page 145.

* For details about auto switches with pre-wired connector, refer to pages 1328 and 1329 in Best Pneumatics No. 2.

Compact Cylinder: Axial Piping Double Acting, Single Rod **Series CQP2**

Specifications



Rod end male thread

Symbol
Double acting,
Single rod

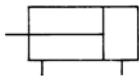

Made to Order
(For details, refer to pages 201 to 235.)

Symbol	Specifications
-XA□	Special rod end shape
-XB6	Heat resistant cylinder (-10 to 150°C) w/o auto switch only
-XB7	Cold resistant cylinder (-40 to 70°C) w/o auto switch only
-XB9	Low-speed cylinder (10 to 50 mm/s)
-XB13	Low-speed cylinder (5 to 50 mm/s)
-XC4	With heavy-duty scraper, ø32 to ø100 only
-XC6	Piston rod/Retaining ring/Rod end nut material: Stainless steel
-XC35	With coil scraper
-XC36	With boss on rod side
-XC85	Grease for food processing equipment
-X271	Fluororubber seals

Refer to pages 141 to 145 for the specifications of cylinders with autoswitches.

- Auto switch proper mounting position (detection at stroke end) and its mounting height
- Minimum stroke for auto switch mounting
- Operating range
- Auto switch mounting brackets/Part no.

Pneumatic type

Bore size (mm)	12	16	20	25	32	40	50	63	80	100		
Action	Double acting, Single rod											
Fluid	Air											
Proof pressure	1.5 MPa											
Maximum operating pressure	1.0 MPa											
Minimum operating pressure	0.07 MPa		0.05 MPa									
Ambient and fluid temperature	Without auto switch: -10 to 70°C (No freezing) With auto switch: -10 to 60°C (No freezing)											
Lubrication	Not required (Non-lube)											
Piston speed	50 to 500 mm/s											
Allowable kinetic energy (J)	Without cushion		0.022	0.038	0.055	0.09	0.15	0.26	0.46	0.77	1.36	2.27
	With rubber bumper		0.043	0.075	0.11	0.18	0.29	0.52	0.91	1.54	2.71	4.54
Stroke length tolerance	+1.0 mm (Note) 0											

Note) Stroke length tolerance does not include the amount of bumper change.

Air-hydro type

Bore size (mm)	20	25	32	40	50	63	80	100
Action	Double acting, Single rod							
Fluid	Turbine oil (Note)							
Proof pressure	1.5 MPa							
Maximum operating pressure	1.0 MPa							
Minimum operating pressure	0.18 MPa				0.1 MPa			
Ambient and fluid temperature	5 to 60°C							
Piston speed	5 to 50 mm/s							
Cushion	None							
Stroke length tolerance	+1.0 mm 0							

Note) Refer to "Handling Precautions for SMC Products" (M-E03-3) for Actuator Precautions (5).

Standard Strokes

Pneumatic type (Non-lube) (mm)

Bore size	Standard stroke
12, 16	5, 10, 15, 20, 25, 30
20, 25	5, 10, 15, 20, 25, 30, 35 40, 45, 50
32, 40	5, 10, 15, 20, 25, 30, 35 40, 45, 50, 75, 100
50, 63 80, 100	10, 15, 20, 25, 30, 35, 40 45, 50, 75, 100

Air-hydro type (mm)

Bore size	Standard stroke
20, 25	5, 10, 15, 20, 25, 30, 35 40, 45, 50
32, 40	5, 10, 15, 20, 25, 30, 35 40, 45, 50, 75, 100
50, 63 80, 100	10, 15, 20, 25, 30, 35, 40 45, 50, 75, 100

Manufacture of Intermediate Strokes

Type	A spacer is installed in the standard stroke body.	
Part no.	Refer to "How to Order" for the standard model number. (P.121)	
Description	Strokes in 1 mm intervals are available by installing a spacer in the standard stroke cylinder.	
Stroke range	Bore size	Stroke range
	12, 16	1 to 29
	20, 25	1 to 49
	32 to 100	1 to 99
Example	Part no.: CQP2B50-57D CQP2B50-75D with 18 mm width spacer inside The B dimension is 115.5 mm.	



- Except air-hydro type
- In the case of spacer type, intermediate strokes with bumper for ø40 to ø100, it can be manufactured in 5 mm intervals in 5 mm and 55 to 95 mm.

Series CQP2

Retaining Ring Installation/Removal

⚠ Caution

- For installation and removal, use an appropriate pair of pliers (tool for installing a type C retaining ring).
- Even if a proper plier (tool for installing a type C retaining ring) is used, it is likely to inflict damage to a human body or peripheral equipment, as a retaining ring may be flown out of the tip of a plier (tool for installing a type C retaining ring). Be much careful with the popping of a retaining ring. Besides, be certain that a retaining ring is placed firmly into the groove of rod cover before supplying air at the time of installment.

Mounting/Removal

- Do not remove the hexagon socket set screw on the side of the rod.
- Be aware that if the hexagon socket set screw is removed with compressed air supplied to the cylinder, an internal steel ball could fly out or the compressed air could be discharged, leading to injury to humans or damage to peripheral equipment.

Type

Bore size (mm)		12	16	20	25	32	40	50	63	80	100	
Pneumatic	Mounting Through-hole (Standard)	●	●	●	●	●	●	●	●	●	●	
	Built-in magnet	●	●	●	●	●	●	●	●	●	●	
	Piping	Pipe thread	M5	M5	M5	M5	Rc1/8	Rc1/8	Rc1/4	Rc1/4	Rc3/8	Rc3/8
			NPT1/8	NPT1/8	NPT1/4	NPT1/4	NPT1/4	NPT3/8	NPT3/8			
			G1/8	G1/8	G1/4	G1/4	G3/8	G3/8				
		Rod end male thread	●	●	●	●	●	●	●	●	●	●
	With rubber bumper	●	●	●	●	●	●	●	●	●	●	
Air-hydro	Mounting Through-hole (Standard)	—	—	●	●	●	●	●	●	●	●	
	Built-in magnet	—	—	●	●	●	●	●	●	●	●	
	Piping	Pipe thread	—	—	M5	M5	Rc1/8	Rc1/8	Rc1/4	Rc1/4	Rc3/8	Rc3/8
	Rod end male thread	—	—	●	●	●	●	●	●	●	●	

Theoretical Output



(N)

Bore size (mm)	Operating direction	Operating pressure (MPa)		
		0.3	0.5	0.7
12	IN	25	42	59
	OUT	34	57	79
16	IN	45	75	106
	OUT	60	101	141
20	IN	71	118	165
	OUT	94	157	220
25	IN	113	189	264
	OUT	147	245	344
32	IN	181	302	422
	OUT	241	402	563
40	IN	317	528	739
	OUT	377	628	880
50	IN	495	825	1150
	OUT	589	982	1370
63	IN	841	1400	1960
	OUT	935	1560	2180
80	IN	1360	2270	3170
	OUT	1510	2510	3520
100	IN	2140	3570	5000
	OUT	2360	3930	5500

Weight

Weight

(g)

Bore size (mm)	Cylinder stroke (mm)											
	5	10	15	20	25	30	35	40	45	50	75	100
12	32	39	46	53	60	67	—	—	—	—	—	—
16	54	63	72	81	90	98	—	—	—	—	—	—
20	70	84	98	112	126	140	154	168	182	196	—	—
25	102	117	132	147	161	176	191	206	220	235	—	—
32	149	173	199	222	246	270	295	319	343	367	487	607
40	224	258	280	310	336	362	388	414	440	467	602	737
50	—	414	455	496	538	579	620	662	703	744	949	1154
63	—	584	632	679	727	774	822	870	917	965	1205	1445
80	—	1085	1163	1242	1320	1399	1477	1556	1634	1713	2108	2503
100	—	1894	1992	2091	2189	2287	2385	2483	2581	2679	3169	3659

Additional Weight

(g)

Bore size (mm)		12	16	20	25	32	40	50	63	80	100
Rod end male thread	Male thread	1.5	3	6	12	26	27	53	53	120	175
	Nut	1	2	4	8	17	17	32	32	49	116
	With rubber bumper	0	0	-2	-3	-3	-7	-9	-18	-31	-56

Calculation: (Example) CQP2B32-20DCM

- Basic weight: CQP2B32-20D..... 222 g
- Additional weight: Rod end male thread 43 g
- With rubber bumper..... -3 g

262 g

Mounting Bolt for CQP2B/Without Auto Switch

Mounting method: Mounting bolt for through-hole mounting of the CQP2B is available as an option. Refer to the following for ordering procedures. Order the actual number of bolts that will be used.

Example) CQ-M3 x 25L 2 pcs.

Material: Chromium molybdenum steel
Surface treatment: Zinc chromated

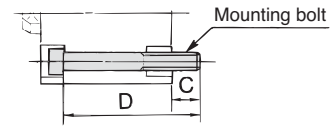

Cylinder model	C	D	Mounting bolt part no.
CQP2B12-5D	6.5	25	CQ-M3 x 25L
-10D		30	x 30L
-15D		35	x 35L
-20D		40	x 40L
-25D		45	x 45L
-30D		50	x 50L
CQP2B16-5D	5	25	CQ-M3 x 25L
-10D		30	x 30L
-15D		35	x 35L
-20D		40	x 40L
-25D		45	x 45L
-30D		50	x 50L
CQP2B20-5D	7.5	25	CQ-M5 x 25L
-10D		30	x 30L
-15D		35	x 35L
-20D		40	x 40L
-25D		45	x 45L
-30D		50	x 50L
-35D		55	x 55L
-40D		60	x 60L
-45D		65	x 65L
-50D		70	x 70L
CQP2B25-5D	9.5	30	CQ-M5 x 30L
-10D		35	x 35L
-15D		40	x 40L
-20D		45	x 45L
-25D		50	x 50L
-30D		55	x 55L
-35D		60	x 60L
-40D		65	x 65L
-45D		70	x 70L
-50D		75	x 75L

Cylinder model	C	D	Mounting bolt part no.	
CQP2B32-5D	9	30	CQ-M5 x 30L	
-10D		35	x 35L	
-15D		40	x 40L	
-20D		45	x 45L	
-25D		50	x 50L	
-30D		55	x 55L	
-35D		60	x 60L	
-40D		65	x 65L	
-45D		70	x 70L	
-50D		75	x 75L	
-75D	7.5	110	x 110L	
-100D		135	x 135L	
CQP2B40-5D		7.5	35	CQ-M5 x 35L
-10D			40	x 40L
-15D			45	x 45L
-20D			50	x 50L
-25D			55	x 55L
-30D			60	x 60L
-35D			65	x 65L
-40D			70	x 70L
-45D	75		x 75L	
-50D	80		x 80L	
-75D	12.5	115	x 115L	
-100D		140	x 140L	
CQP2B50-10D		12.5	45	CQ-M6 x 45L
-15D			50	x 50L
-20D			55	x 55L
-25D			60	x 60L
-30D			65	x 65L
-35D			70	x 70L
-40D			75	x 75L
-45D			80	x 80L
-50D	85		x 85L	
-75D	120		x 120L	
-100D	145	x 145L		

Cylinder model	C	D	Mounting bolt part no.	
CQP2B63-10D	14.5	50	CQ-M8 x 50L	
-15D		55	x 55L	
-20D		60	x 60L	
-25D		65	x 65L	
-30D		70	x 70L	
-35D		75	x 75L	
-40D		80	x 80L	
-45D		85	x 85L	
-50D		90	x 90L	
-75D		125	x 125L	
-100D	15	150	x 150L	
CQP2B80-10D		15	55	CQ-M10 x 55L
-15D			60	x 60L
-20D			65	x 65L
-25D			70	x 70L
-30D			75	x 75L
-35D			80	x 80L
-40D			85	x 85L
-45D			90	x 90L
-50D			95	x 95L
-75D	130		x 130L	
-100D	15.5	155	x 155L	
CQP2B100-10D		15.5	65	CQ-M10 x 65L
-15D			70	x 70L
-20D			75	x 75L
-25D			80	x 80L
-30D			85	x 85L
-35D			90	x 90L
-40D			95	x 95L
-45D			100	x 100L
-50D			105	x 105L
-75D	140		x 140L	
-100D	165	x 165L		

Standard

Large Bore Size

Long Stroke

Non-rotating Rod

Axial Piping

Anti-lateral Load

With End Lock

Water Resistant

With Auto Switch

Auto Switch

Made to Order

Series CQP2

Construction

Standard

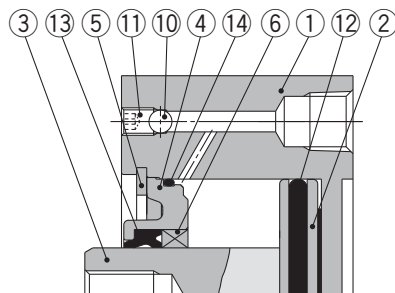
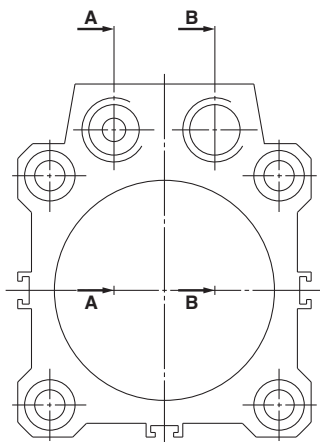

A-A section (Port on rod end)

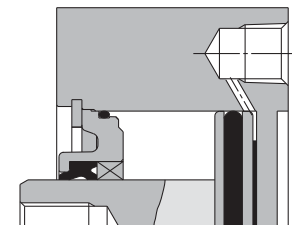

B-B section (Port on head end)

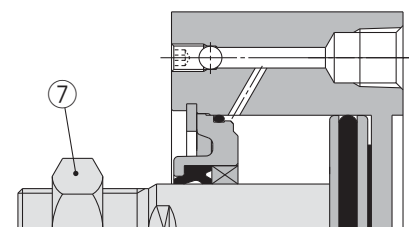

Rod end male thread

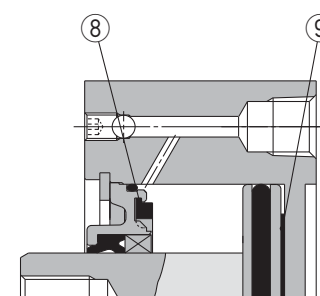

With rubber bumper

Component Parts

No.	Description	Material	Note
1	Cylinder tube	Aluminum alloy	Hard anodised
2	Piston	Aluminum alloy	Chromated
3	Piston rod	Stainless steel	ø12 to ø25
		Carbon steel	ø32 to ø100, Hard chrome plated
4	Collar	Aluminum alloy	ø12 to ø40, Anodised
		Aluminum alloy casted	ø50 to ø100, Chromated, Painted
5	Retaining ring	Carbon tool steel	Phosphate coated
6	Bushing	Bearing alloy	ø50 to ø100
7	Rod end nut	Carbon steel	Nickel plated
8	Bumper A	Urethane	
9	Bumper B	Urethane	
10	Steel ball	Carbon steel	
11	Hexagon socket head set screw	Alloy steel	Nickel plated
12	Piston seal	NBR	
13	Rod seal	NBR	
14	Gasket	NBR	

Replacement Parts/Seal Kit

Bore size (mm)	Kit no.		Contents
	Pneumatic type (Non-lube)	Air-hydro type	
12	CQ2B12-PS	—	Kits include items 12, 13, 14 from the table.
16	CQ2B16-PS	—	
20	CQ2B20-PS	CQ2BH20-PS	
25	CQ2B25-PS	CQ2BH25-PS	
32	CQ2B32-PS	CQ2BH32-PS	
40	CQ2B40-PS	CQ2BH40-PS	
50	CQ2B50-PS	CQ2BH50-PS	
63	CQ2B63-PS	CQ2BH63-PS	
80	CQ2B80-PS	CQ2BH80-PS	
100	CQ2B100-PS	CQ2BH100-PS	

* Seal kit includes 12, 13, 14. Order the seal kit based on each bore size.

* Since the seal kit does not include a grease pack, order it separately.

Grease pack part no.: GR-S-010 (10 g)

Copper and Fluorine-free Series (For CRT Manufacturing Process)

20 — CQP2B Bore size — Stroke D
 Copper and fluorine-free series ø12, ø16, ø20, ø25, ø32, ø40, ø50, ø63, ø80, ø100

For preventing the influence of copper ions or halogen ions during CRT manufacturing processes, copper and fluorine materials are not used in the component parts.

Specifications

Bore size (mm)	12	16	20	25	32	40	50	63	80	100
Action	Double acting, Single rod									
Proof pressure	1.5 MPa									
Max. operating pressure	1.0 MPa									
Rubber bumper	None									
Piping	Pipe thread									
Piston speed	50 to 500 mm/s									
Mounting	Through-hole									
Auto switch	Mountable									

Axial Piping: Double Acting, Single Rod Series CDQP2 With Auto Switch

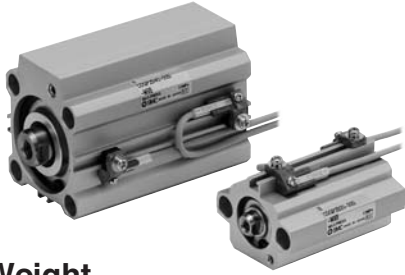

Refer to the below pages for further information on auto switches.

Auto switch proper mounting position and its mounting height	P.141 to 145
Minimum stroke for auto switch mounting	
Operating range	
Auto switch mounting brackets/Part no.	

Weight

Additional Weight (g)

Bore size (mm)		12	16	20	25	32
Rod end male thread	Male thread	1.5	3	6	12	26
	Nut	1	2	4	8	17
With rubber bumper		0	-1	-2	-3	-3

Bore size (mm)		40	50	63	80	100
Rod end male thread	Male thread	27	53	53	120	175
	Nut	17	32	32	49	116
With rubber bumper		-7	-9	-18	-31	-56

Weight (g)

Bore size (mm)	Cylinder stroke (mm)											
	5	10	15	20	25	30	35	40	45	50	75	100
12	54	62	69	75	82	89	—	—	—	—	—	—
16	91	99	107	115	123	131	—	—	—	—	—	—
20	121	135	147	161	175	188	201	214	228	242	—	—
25	177	190	203	217	230	244	257	270	284	297	—	—
32	217	242	266	290	315	339	363	387	412	436	557	679
40	319	345	371	397	423	449	475	502	528	554	684	814
50	—	546	588	629	670	712	753	794	836	877	1084	1291
63	—	764	812	859	907	955	1002	1050	1098	1145	1384	1622
80	—	1377	1455	1534	1612	1691	1769	1848	1926	2005	2397	2790
100	—	2296	2394	2492	2590	2688	2786	2884	2982	3080	3570	4060

Calculation: (Example CDQP2B32-20DCM)
 • Basic weight: CDQP2B32-20D..... 290 g
 • Additional weight: Rod end male thread... 43 g
 With rubber bumper... -3 g
 330 g

Add each weight of auto switches when auto switches are mounted.

Auto Switch Mounting Bracket/Weight

Mounting bracket part no.	Applicable bore size	Weight (g)
BQ-1	ø12 to ø25	1.5
BQ-2	ø32 to ø100	1.5
BQ2-012	ø12 to ø100	5

Construction

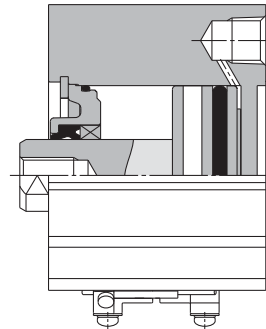
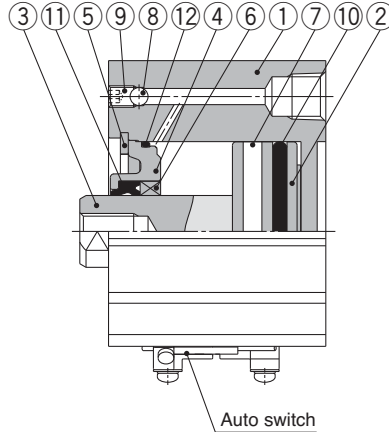
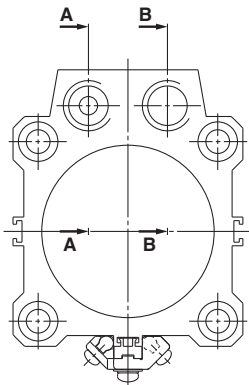

A-A section (Port on rod end)

B-B section (Port on head end)

Component Parts

No.	Description	Material	Note
1	Cylinder tube	Aluminum alloy	Hard anodised
2	Piston	Aluminum alloy	Chromated
3	Piston rod	Stainless steel	ø12 to ø25
		Carbon steel	ø32 to ø100, Hard chrome plated
4	Collar	Aluminum alloy	ø12 to ø40, Anodised
		Aluminum alloy casted	ø50 to ø100, Chromated, Painted
5	Retaining ring	Carbon tool steel	Phosphate coated
6	Bushing	Bearing alloy	ø50 to ø100
7	Magnet	—	—
8	Steel ball	Carbon steel	—
9	Hexagon socket head set screw	Alloy steel	Nickel plated
10	Piston seal	NBR	—
11	Rod seal	NBR	—
12	Gasket	NBR	—

Replacement Parts/Seal Kit

Bore size (mm)	Kit no.		Contents
	Pneumatic type (Non-lube)	Air-hydro type	
12	CQ2B12-PS	—	Kits include items ⑩, ⑪, ⑫ from the table.
16	CQ2B16-PS	—	
20	CQ2B20-PS	CQ2BH20-PS	
25	CQ2B25-PS	CQ2BH25-PS	
32	CQ2B32-PS	CQ2BH32-PS	
40	CQ2B40-PS	CQ2BH40-PS	
50	CQ2B50-PS	CQ2BH50-PS	
63	CQ2B63-PS	CQ2BH63-PS	
80	CQ2B80-PS	CQ2BH80-PS	
100	CQ2B100-PS	CQ2BH100-PS	

* Seal kit includes ⑩, ⑪, ⑫. Order the seal kit based on each bore size.

* Since the seal kit does not include a grease pack, order it separately.

Grease pack part no.: GR-S-010 (10 g)

Series CQP2

Mounting Bolt for CDQP2B/With Auto Switch

Mounting method: Mounting bolt for through-hole mounting of the CDQP2B is available as an option. Refer to the following for ordering procedures. Order the actual number of bolts that will be used.

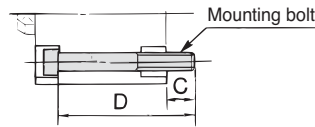

Example) CQ-M3 x 35L 2 pcs.

Material: Chromium molybdenum steel
Surface treatment: Zinc chromated

Cylinder model	C	D	Mounting bolt part no.
CDQP2B12-5D	5.5	35	CQ-M3 x 35L
-10D		40	x 40L
-15D		45	x 45L
-20D		50	x 50L
-25D		55	x 55L
-30D		60	x 60L
CDQP2B16-5D	8	40	CQ-M3 x 40L
-10D		45	x 45L
-15D		50	x 50L
-20D		55	x 55L
-25D		60	x 60L
-30D		65	x 65L
CDQP2B20-5D	10.5	40	CQ-M5 x 40L
-10D		45	x 45L
-15D		50	x 50L
-20D		55	x 55L
-25D		60	x 60L
-30D		65	x 65L
-35D		70	x 70L
-40D		75	x 75L
-45D		80	x 80L
-50D		85	x 85L
CDQP2B25-5D	9.5	40	CQ-M5 x 40L
-10D		45	x 45L
-15D		50	x 50L
-20D		55	x 55L
-25D		60	x 60L
-30D		65	x 65L
-35D		70	x 70L
-40D		75	x 75L
-45D		80	x 80L
-50D		85	x 85L

Cylinder model	C	D	Mounting bolt part no.	
CDQP2B32-5D	9	40	CQ-M5 x 40L	
-10D		45	x 45L	
-15D		50	x 50L	
-20D		55	x 55L	
-25D		60	x 60L	
-30D		65	x 65L	
-35D		70	x 70L	
-40D		75	x 75L	
-45D		80	x 80L	
-50D		85	x 85L	
-75D	110	x 110L		
-100D	135	x 135L		
CDQP2B40-5D	7.5	45	CQ-M5 x 45L	
-10D		50	x 50L	
-15D		55	x 55L	
-20D		60	x 60L	
-25D		65	x 65L	
-30D		70	x 70L	
-35D		75	x 75L	
-40D		80	x 80L	
-45D		85	x 85L	
-50D		90	x 90L	
-75D		115	x 115L	
-100D		140	x 140L	
CDQP2B50-10D		12.5	55	CQ-M6 x 55L
-15D			60	x 60L
-20D	65		x 65L	
-25D	70		x 70L	
-30D	75		x 75L	
-35D	80		x 80L	
-40D	85		x 85L	
-45D	90		x 90L	
-50D	95		x 95L	
-75D	120		x 120L	
-100D	145		x 145L	

Cylinder model	C	D	Mounting bolt part no.
CDQP2B63-10D	14.5	60	CQ-M8 x 60L
-15D		65	x 65L
-20D		70	x 70L
-25D		75	x 75L
-30D		80	x 80L
-35D		85	x 85L
-40D		90	x 90L
-45D		95	x 95L
-50D		100	x 100L
-75D		125	x 125L
-100D	150	x 150L	
CDQP2B80-10D	15	65	CQ-M10 x 65L
-15D		70	x 70L
-20D		75	x 75L
-25D		80	x 80L
-30D		85	x 85L
-35D		90	x 90L
-40D		95	x 95L
-45D		100	x 100L
-50D		105	x 105L
-75D		130	x 130L
-100D	155	x 155L	
CDQP2B100-10D	15.5	75	CQ-M10 x 75L
-15D		80	x 80L
-20D		85	x 85L
-25D		90	x 90L
-30D		95	x 95L
-35D		100	x 100L
-40D		105	x 105L
-45D		110	x 110L
-50D		115	x 115L
-75D		140	x 140L
-100D	165	x 165L	

Dimensions

∅12 to ∅100/Without Auto Switch

∅12 to ∅25

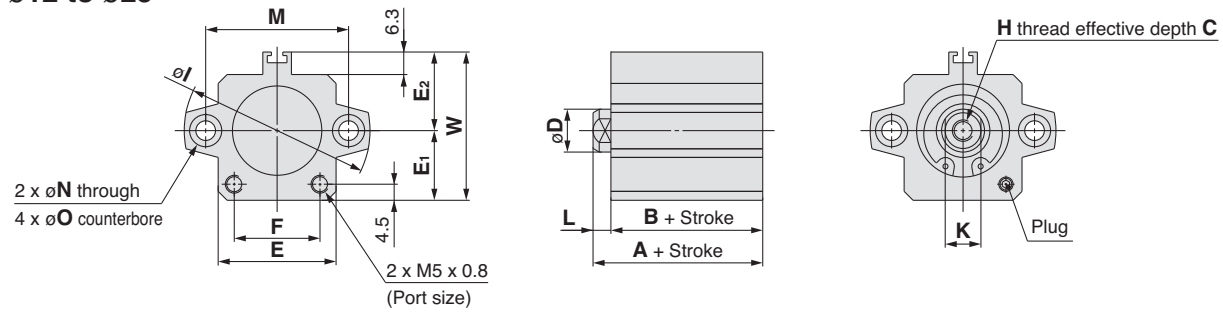

Rod end male thread

Width across flat B₁

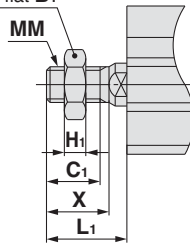

Rod End Male Thread

(mm)

Bore size (mm)	B ₁	C ₁	H ₁	L ₁	MM	X
12	8	9	4	14	M5 x 0.8	10.5
16	10	10	5	15.5	M6 x 1.0	12
20	13	12	5	18.5	M8 x 1.25	14
25	17	15	6	22.5	M10 x 1.25	17.5

Standard

(mm)

Bore size (mm)	Stroke range (mm)	A	B	C	D	E	E ₁	E ₂	F	H	I	K	L	M	N	O	W
12	5 to 30	20.5	17	6	6	23	13	14	14	M3 x 0.5	32	5	3.5	22	3.5	6.5 depth 3.5	27
16	5 to 30	22	18.5	8	8	26	15	17	17	M4 x 0.7	38	6	3.5	28	3.5	6.5 depth 3.5	32
20	5 to 50	24	19.5	7	10	30	17	19	21	M5 x 0.8	47	8	4.5	36	5.5	9 depth 7	36
25	5 to 50	27.5	22.5	12	12	33	19.5	22	24	M6 x 1.0	52	10	5	40	5.5	9 depth 7	41.5

∅32 to ∅100

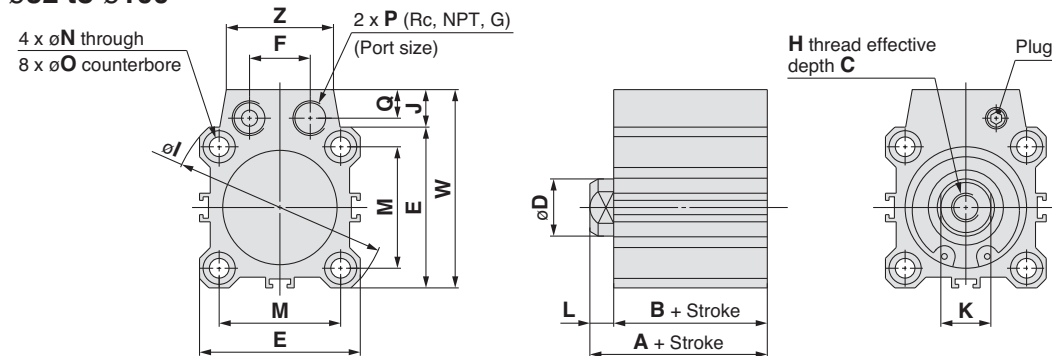

Rod end male thread

Width across flat B₁

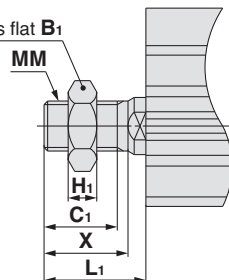

Rod End Male Thread

(mm)

Bore size (mm)	B ₁	C ₁	H ₁	L ₁	MM	X
32	22	20.5	8	28.5	M14 x 1.5	23.5
40	22	20.5	8	28.5	M14 x 1.5	23.5
50	27	26	11	33.5	M18 x 1.5	28.5
63	27	26	11	33.5	M18 x 1.5	28.5
80	32	32.5	13	43.5	M22 x 1.5	35.5
100	41	32.5	16	43.5	M26 x 1.5	35.5

Standard

(mm)

Bore size (mm)	Stroke range (mm)	A	B	C	D	E	F	H	I	J	K	L	M	N	O	P	Q	W	Z
32	5 to 50	30	23	13	16	45	17	M8 x 1.25	60	10.5	14	7	34	5.5	9 depth 7	1/8	8	55.5	30
	75, 100	40	33																
40	5 to 50	36.5	29.5	13	16	52	17	M8 x 1.25	69	10	14	7	40	5.5	9 depth 7	1/8	8	62	30
	75, 100	46.5	39.5																
50	10 to 50	38.5	30.5	15	20	64	22	M10 x 1.5	86	13	17	8	50	6.6	11 depth 8	1/4	10	77	39
	75, 100	48.5	40.5																
63	10 to 50	44	36	15	20	77	22	M10 x 1.5	103	13	17	8	60	9	14 depth 10.5	1/4	10	90	39
	75, 100	54	46																
80	10 to 50	53.5	43.5	21	25	98	26	M16 x 2.0	132	16	22	10	77	11	17.5 depth 13.5	3/8	12.5	114	48
	75, 100	63.5	53.5																
100	10 to 50	65	53	27	30	117	26	M20 x 2.5	156	17.5	27	12	94	11	17.5 depth 13.5	3/8	12.5	134.5	48
	75, 100	75	63																

Note) The external dimensions with rubber bumper are the same as those of the standard, as shown above.

* For details about the rod end nut and accessory brackets, refer to page 23.

Standard
Large Bore Size
Long Stroke
Non-rotating Rod
Axial Piping
Anti-lateral Load
With End Lock
Water Resistant
With Auto Switch
Auto Switch
Made to Order

Series CQP2

Dimensions

ø12 to ø100/With Auto Switch

ø12 to ø25

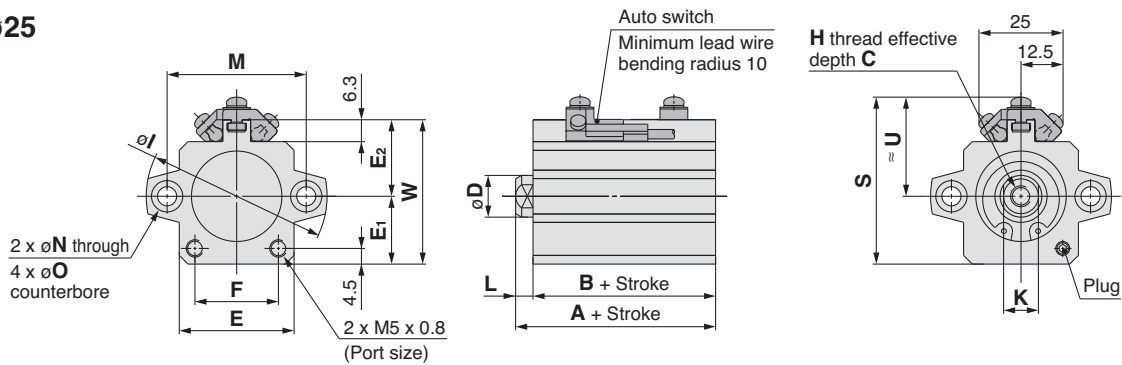

Rod end male thread

Width across flat B₁

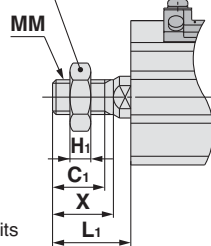

Rod End Male Thread

(mm)

Bore size (mm)	B ₁	C ₁	H ₁	L ₁	MM	X
12	8	9	4	14	M5 x 0.8	10.5
16	10	10	5	15.5	M6 x 1.0	12
20	13	12	5	18.5	M8 x 1.25	14
25	17	15	6	22.5	M10 x 1.25	17.5

Standard

For auto switch proper mounting position and its mounting height, refer to pages 141 to 145.

(mm)

Bore size (mm)	Stroke range (mm)	A	B	C	D	E	E ₁	E ₂	F	H	I	K	L	M	N	O	S	U	W
12	5 to 30	31.5	28	6	6	23	13	14	14	M3 x 0.5	32	5	3.5	22	3.5	6.5 depth 3.5	33.5	20.5	27
16	5 to 30	34	30.5	8	8	26	15	17	17	M4 x 0.7	38	6	3.5	28	3.5	6.5 depth 3.5	38.5	23.5	32
20	5 to 50	36	31.5	7	10	30	17	19	21	M5 x 0.8	47	8	4.5	36	5.5	9 depth 7	42.5	25.5	36
25	5 to 50	37.5	32.5	12	12	33	19.5	22	24	M6 x 1.0	52	10	5	40	5.5	9 depth 7	48	28.5	41.5

Note) The external dimensions with rubber bumper are the same as those of the standard, as shown above.

ø32 to ø100

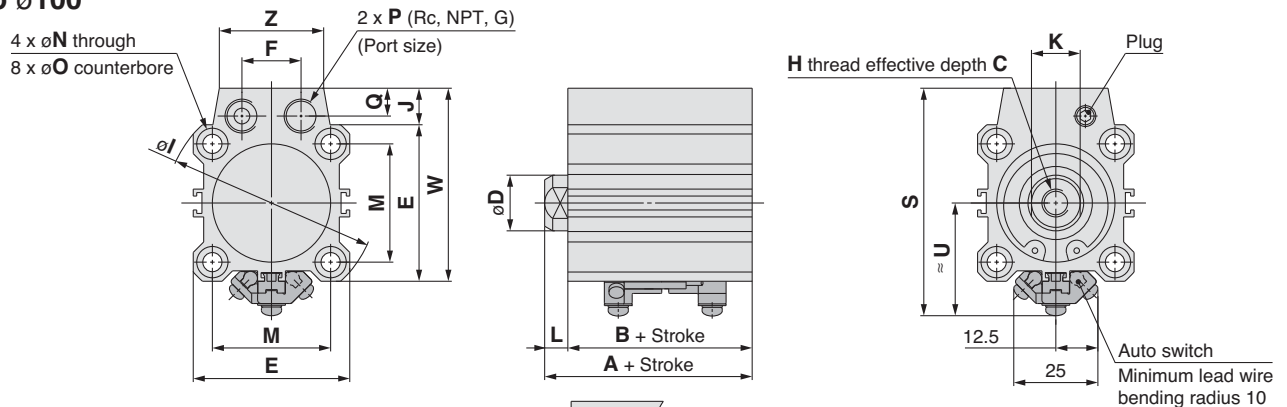

Rod end male thread

Width across flat B₁

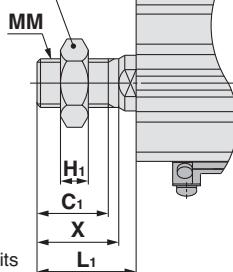

Rod End Male Thread

(mm)

Bore size (mm)	B ₁	C ₁	H ₁	L ₁	MM	X
32	22	20.5	8	28.5	M14 x 1.5	23.5
40	22	20.5	8	28.5	M14 x 1.5	23.5
50	27	26	11	33.5	M18 x 1.5	28.5
63	27	26	11	33.5	M18 x 1.5	28.5
80	32	32.5	13	43.5	M22 x 1.5	35.5
100	41	32.5	16	43.5	M26 x 1.5	35.5

Standard

For auto switch proper mounting position and its mounting height, refer to pages 141 to 145.

(mm)

Bore size (mm)	Stroke range (mm)	A	B	C	D	E	F	H	I	J	K	L	M	N	O	P	Q	S	U	W	Z
32	5 to 100	40	33	13	16	45	17	M8 x 1.25	60	10.5	14	7	34	5.5	9 depth 7	1/8	8	65.5	32.5	55.5	30
40	5 to 100	46.5	39.5	13	16	52	17	M8 x 1.25	69	10	14	7	40	5.5	9 depth 7	1/8	8	72	36	62	30
50	10 to 100	48.5	40.5	15	20	64	22	M10 x 1.5	86	13	17	8	50	6.6	11 depth 8	1/4	10	87	42	77	39
63	10 to 100	54	46	15	20	77	22	M10 x 1.5	103	13	17	8	60	9	14 depth 10.5	1/4	10	100	48.5	90	39
80	10 to 100	63.5	53.5	21	25	98	26	M16 x 2.0	132	16	22	10	77	11	17.5 depth 13.5	3/8	12.5	123.5	58.5	114	48
100	10 to 100	75	63	27	30	117	26	M20 x 2.5	156	17.5	27	12	94	11	17.5 depth 13.5	3/8	12.5	144.5	68.5	134.5	48

Note) The external dimensions with rubber bumper are the same as those of the standard, as shown above. * For details about the rod end nut and accessory brackets, refer to page 23.

Compact Cylinder: Axial Piping Single Acting, Single Rod Series CQP2

ø12, ø16, ø20, ø25, ø32, ø40, ø50

How to Order

Without auto switch

CQP2B 50 - 10 T

With auto switch

CDQP2B 50 - 10 T - M9BW

With auto switch
(Built-in magnet)

Axial piping

Mounting

B Through-hole

* Cylinder mounting bolts are not included.
Order them separately referring to
"Mounting Bolt for C(D)QP2B" on pages
132 and 135.

Built-in Magnet Cylinder Model

If a built-in magnet cylinder without an auto switch is required, there is no need to enter the symbol for the auto switch.
(Example) CDQP2B32-10S

Bore size

12	12 mm
16	16 mm
20	20 mm
25	25 mm
32	32 mm
40	40 mm
50	50 mm

Port thread type

—	M thread	ø12 to ø25
	Rc	
TN	NPT	ø32 to ø50
TF	G	

Made to Order
Refer to the next page
for details.

Number of auto switches

—	2 pcs.
S	1 pc.
n	"n" pcs.

Auto switch

— Without auto switch

* Refer to the below table for applicable auto switches.

Body option

—	Standard (Rod end female thread)
M	Rod end male thread

Action

S	Single acting, Spring return
T	Single acting, Spring extend

Cylinder stroke (mm)

Refer to the next page for standard strokes.

Applicable Auto Switches/Refer to pages 1263 to 1371 in Best Pneumatics No. 2 for further information on auto switches.

Type	Special function	Electrical entry	Indicator light	Wiring (Output)	Load voltage		Auto switch model		Lead wire length (m)					Pre-wired connector	Applicable load			
					DC	AC	Perpendicular	In-line	0.5 (-)	1 (M)	3 (L)	5 (Z)	None (N)					
Solid state auto switch	—	Grommet	—	3-wire (NPN)	24 V	5 V, 12 V	—	M9NV	M9N	●	●	●	○	—	○	IC circuit	Relay, PLC	
				3-wire (PNP)				M9PV	M9P	●	●	●	○	—	○			
		Connector	2-wire	M9BV				M9B	●	●	●	○	—	○	—			
			J79C	—				●	—	●	●	—	—	—				
	Diagnostic indication (2-colour indication)	Grommet	Yes	3-wire (NPN)	24 V	5 V, 12 V	—	M9NWV	M9NW	●	●	●	○	—	○	IC circuit	Relay, PLC	
				3-wire (PNP)				M9PWV	M9PW	●	●	●	○	—	○			
				2-wire				M9B WV	M9B W	●	●	●	○	—	○			—
				3-wire (NPN)				M9NAV**	M9NA**	○	○	●	○	—	○			
				3-wire (PNP)				M9PAV**	M9PA**	○	○	●	○	—	○			IC circuit
				2-wire				M9BAV**	M9BA**	○	○	●	○	—	○			
With diagnostic output (2-colour indication)	4-wire	—	F79F	●	—	●	○	—	○	IC circuit								
Reed auto switch	—	Grommet	Yes	3-wire (NPN equivalent)	24 V	5 V, 12 V	100 V or less	A96V	A96	●	—	●	—	—	—	IC circuit	Relay, PLC	
				—				A72	A72H	●	—	●	—	—	—			
				12 V				A93V	A93	●	—	●	—	—	—			
		Connector	No	2-wire				5 V, 12 V	A90V	A90	●	—	●	—	—	—		IC circuit
				12 V				A73C	—	●	—	●	●	●	—			
				5 V, 12 V				A80C	—	●	—	●	●	●	—	IC circuit		
				24 V or less				A79W	—	●	—	●	—	—	—			

* Water resistant type auto switches can be mounted on the above models, but in such case SMC cannot guarantee water resistance. Consult with SMC regarding water resistant types with the above model numbers.

* Lead wire length symbols: 0.5 m — (Example) M9NW
1 m M (Example) M9NWM
3 m L (Example) M9NWL
5 m Z (Example) M9NWZ
None N (Example) J79CN

* Solid state auto switches marked with "○" are produced upon receipt of order.

* There are other applicable auto switches other than the listed above. For details, refer to page 145.

* For details about auto switches with pre-wired connector, refer to pages 1328 and 1329 in Best Pneumatics No. 2.

Series CQP2

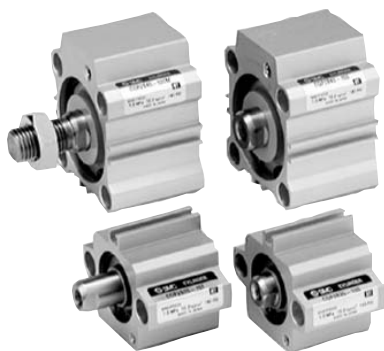

Symbol

Single acting,
Spring return

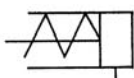

Single acting,
Spring extend

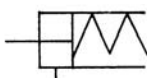

Made to Order

(For details, refer to pages 201 to 235.)

Symbol	Specifications
-XA□	Special rod end shape
-XC6	Piston rod/Retaining ring/Rod end nut material: Stainless steel
-XC36	With boss on rod side
-XC85	Grease for food processing equipment
-X271	Fluororubber seals

Retaining Ring Installation/Removal

⚠ Caution

- For installation and removal, use an appropriate pair of pliers (tool for installing a type C retaining ring).
- Even if a proper plier (tool for installing a type C retaining ring) is used, it is likely to inflict damage to a human body or peripheral equipment, as a retaining ring may be flown out of the tip of a plier (tool for installing a type C retaining ring). Be much careful with the popping of a retaining ring. Besides, be certain that a retaining ring is placed firmly into the groove of rod cover before supplying air at the time of installment.

Mounting/Removal

- Do not remove the hexagon socket set screw on the side of the rod.
 - Be aware that if the hexagon socket set screw is removed with compressed air supplied to the cylinder, an internal steel ball could fly out or the compressed air could be discharged, leading to injury to humans or damage to peripheral equipment.

Specifications

Bore size (mm)	12	16	20	25	32	40	50
Action	Double acting, Single rod						
Fluid	Air						
Proof pressure	1.5 MPa						
Maximum operating pressure	1.0 MPa						
Minimum operating pressure (MPa)	0.25	0.25	0.18	0.18	0.17	0.15	0.13
Ambient and fluid temperature	Without auto switch: -10 to 70°C (No freezing) With auto switch: -10 to 60°C (No freezing)						
Lubrication	Not required (Non-lube)						
Piston speed	50 to 500 mm/s						
Allowable kinetic energy (J)	0.022	0.038	0.055	0.09	0.15	0.26	0.46
Stroke length tolerance	+1.0 mm 0						

Standard Strokes

Bore size	Standard stroke (mm)
12	5, 10
16	
20	
25	
32	
40	10, 20
50	

Manufacture of Intermediate Strokes

(Except single acting, spring return)

Type	A spacer is installed in the standard stroke body.	
Part no.	Refer to "How to Order" for the standard model number. (P. 121)	
Description	Strokes in 1 mm intervals are available by installing a spacer in the standard stroke cylinder.	
Stroke range	Bore size	Stroke range
	12 to 40	1 to 9
	50	1 to 19
Example	Part no.: CQP2B20-3T CQP2B20-5T with 2 mm width spacer inside The B dimension is 24.5 mm.	

Type

Bore size (mm)		12	16	20	25	32	40	50	
Pneumatic	Mounting	Through-hole (Standard)	●	●	●	●	●	●	
		Built-in magnet	●	●	●	●	●	●	
	Piping	Pipe thread	M5	M5	M5	M5	Rc1/8	Rc1/8	Rc1/4
							NPT1/8	NPT1/8	NPT1/4
	Rod end male thread	●	●	●	●	G1/8	G1/8	G1/4	

Refer to pages 141 to 145 for the specifications of cylinders with autoswitches.

- Auto switch proper mounting position (detection at stroke end) and its mounting height
- Minimum stroke for auto switch mounting
- Operating range
- Auto switch mounting brackets/Part no.

Theoretical Output

Action	Bore size (mm)	Operating pressure (MPa)		
		0.3	0.5	0.7
Spring return	12	21	44	66
	16	45	86	126
	20	79	142	205
	25	126	224	323
	32	211	372	533
	40	338	589	841
	50	535	928	1316
Spring extend	12	14	31	48
	16	24	54	85
	20	71	118	165
	25	113	189	264
	32	181	302	422
	40	317	528	739
	50	495	825	1150

Mounting Bolt for CQP2B/Without Auto Switch

Mounting method: Mounting bolt for through-hole mounting of the CQP2B is available as an option. Refer to the following for ordering procedures. Order the actual number of bolts that will be used.

Example) CQ-M3 x 25L 2 pcs.

Material: Chromium molybdenum steel
Surface treatment: Zinc chromated

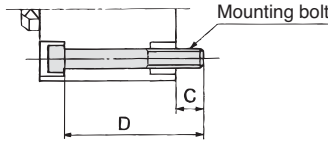

Spring Return

Cylinder model	C	D	Mounting bolt part no.
CQP2B12-5S	6.5	25	CQ-M3 x 25L
-10S		30	x 30L
CQP2B16-5S	5	25	CQ-M3 x 25L
-10S		30	x 30L
CQP2B20-5S	7.5	25	CQ-M5 x 25L
-10S		30	x 30L
CQP2B25-5S	9.5	30	CQ-M5 x 30L
-10S		35	x 35L
CQP2B32-5S	9	30	CQ-M5 x 30L
-10S		35	x 35L
CQP2B40-5S	7.5	35	CQ-M5 x 35L
-10S		40	x 40L
CQP2B50-10S	12.5	45	CQ-M6 x 45L
-20S		55	x 55L

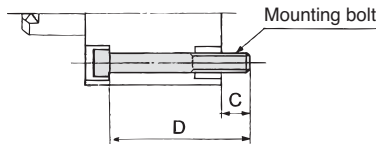

Spring Extend

Cylinder model	C	D	Mounting bolt part no.
CQP2B12-5T	6.5	25	CQ-M3 x 25L
-10T		30	x 30L
CQP2B16-5T	5	25	CQ-M3 x 25L
-10T		30	x 30L
CQP2B20-5T	7.5	25	CQ-M5 x 25L
-10T		30	x 30L
CQP2B25-5T	9.5	30	CQ-M5 x 30L
-10T		35	x 35L
CQP2B32-5T	9	30	CQ-M5 x 30L
-10T		35	x 35L
CQP2B40-5T	7.5	35	CQ-M5 x 35L
-10T		40	x 40L
CQP2B50-10T	12.5	45	CQ-M6 x 45L
-20T		55	x 55L

Weight

Action	Bore size (mm)	Cylinder stroke (mm)			
		5	10	15	20
Spring return	12	33	40	—	—
	16	55	64	—	—
	20	68	83	—	—
	25	103	118	—	—
	32	149	173	—	—
	40	236	262	—	—
	50	—	426	—	691
Spring extend	12	33	40	—	—
	16	55	64	—	—
	20	73	87	—	—
	25	109	124	—	—
	32	160	180	—	—
	40	262	284	—	—
	50	—	468	—	540

Additional Weight

Bore size (mm)		12	16	20	25	32	40	50
Rod end male thread	Male thread	1.5	3	6	12	26	27	53
	Nut	1	2	4	8	17	17	32

Calculation: (Example) **CQP2B32-10SM**

- Basic weight: CQP2B32-10S173 g
 - Additional weight: Rod end male thread 43 g
- 216 g

Spring Force

Single Acting, Spring Return (N)

Bore size (mm)	Stroke (mm)	Spring reaction force (N)	
		Second	First
12	5	13	8.6
	10	13	3.9
16	5	15	10.3
	10	15	5.9
20	5	15	10
	10	15	5.9
25	5	20	16
	10	20	11
32	5	30	23
	10	30	16
40	5	30	13
	10	39	21
50	10	50	30
	20	54	24

Single acting, Spring return

Spring state with first mounting load

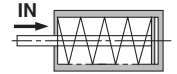

When spring is set in cylinder

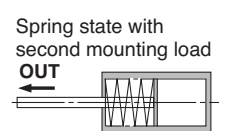

When spring is compressed with air

Single Acting, Spring Extend (N)

Bore size (mm)	Stroke (mm)	Spring reaction force (N)	
		Second	First
12	5	11	2.9
	10	9.7	2.8
16	5	20	3.9
	10	20	3.9
20	5	27	5.3
	10	27	5.9
25	5	29	9.8
	10	29	9.8
32	5	29	20
	10	29	20
40	5	29	20
	10	29	20
50	10	83	24
	20	83	24

Single acting, Spring extend

Spring state with first mounting load



When spring is set in cylinder

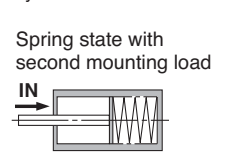

When spring is compressed with air

Standard
Large Bore Size
Long Stroke
Non-rotating Rod
Axial Piping
Anti-lateral Load
With End Lock
Water Resistant
With Auto Switch
Auto Switch
Made to Order

Series CQP2

Construction

Spring return

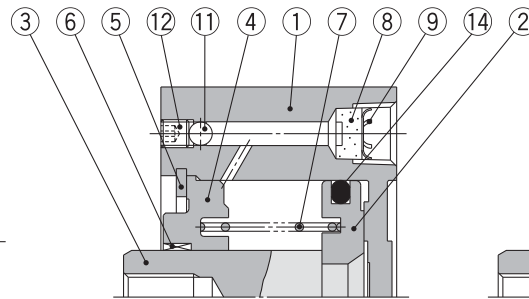
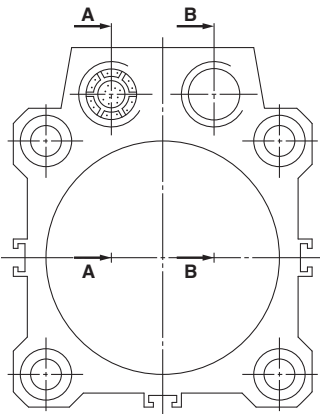

A-A section (Port on rod side)

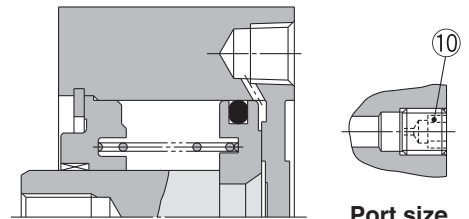

B-B section (Port on head side)

Port size
M5

Spring extend

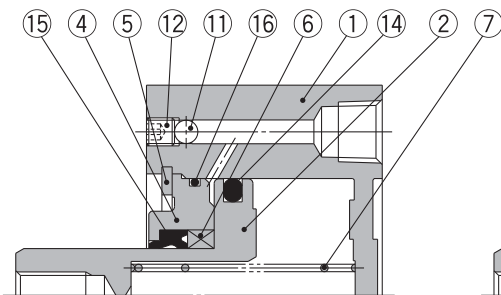

A-A section (Port on rod side)

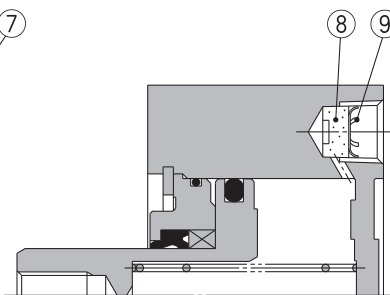

B-B section (Port on head side)

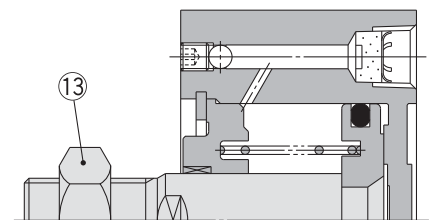

Rod end male thread

Component Parts

No.	Description	Material	Note
1	Cylinder tube	Aluminum alloy	Hard anodised
2*	Piston	Aluminum alloy	Chromated
3	Piston rod	Stainless steel	ø12 to ø25
		Carbon steel	ø32 to ø50, Hard chrome plated
4	Collar	Aluminum alloy	ø12 to ø40, Anodised
		Aluminum alloy casted	ø50, Chromate, Painted
5	Retaining ring	Carbon tool steel	Phosphate coated
6	Bushing	Bearing alloy	
7	Return spring	Piano wire	Zinc chromated
8	Bronze element	Sintered metallic BC	Port size Rc1/8, 1/4
9	Retaining ring	Carbon tool steel	
10	Plug with fixed orifice	Alloy steel	Port size M5
11	Steel ball	Carbon steel	
12	Hexagon socket head set screw	Alloy steel	Nickel plated
13	Rod end nut	Carbon steel	Nickel plated

* On spring extend (Type T), piston and piston rod are integrated (stainless steel).

No.	Description	Material	Note
14	Piston seal	NBR	
15	Rod seal	NBR	
16	Gasket	NBR	

Replacement Parts/Seal Kit

Bore size (mm)	Kit no. (Single acting/Spring return)	Kit no. (Single acting/Spring extend)
12	CQ2B12-S-PS	CQ2B12-T-PS
16	CQ2B16-S-PS	CQ2B16-T-PS
20	CQ2B20-S-PS	CQ2B20-T-PS
25	CQ2B25-S-PS	CQ2B25-T-PS
32	CQ2B32-S-PS	CQ2B32-T-PS
40	CQ2B40-S-PS	CQ2B40-T-PS
50	CQ2B50-S-PS	CQ2B50-T-PS
Contents	Kits include item 14 from the table.	Kits include items 14, 15, 16 from the table.
How to Order	* Seal kit includes 14. Order the seal kit, based on each bore size.	* Seal kit includes 14, 15, 16. Order the seal kit, based on each bore size.

* Since the seal kit does not include a grease pack, order it separately.
Grease pack part no.: GR-S-010 (10 g)

Copper and Fluorine-free Series (For CRT Manufacturing Process)

20 — CQP2B Bore size — Stroke $\frac{S}{T}$ (M)
Copper and fluorine-free series ø12, ø16, ø20, ø25, ø32, ø40, ø50

For preventing the influence of copper ions or halogen ions during CRT manufacturing processes, copper and fluorine materials are not used in the component parts.

Specifications

Bore size (mm)	12	16	20	25	32	40	50
Action	Single acting, Single rod						
Proof pressure	1.5 MPa						
Max. operating pressure	1.0 MPa						
Rubber bumper	None						
Piping	Pipe thread						
Piston speed	50 to 500 mm/s						
Mounting	Through-hole						
Auto switch	Mountable						

Axial Piping: Single Acting, Single Rod Series **CDQP2** With Auto Switch

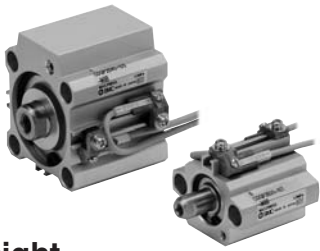

Refer to the below pages for further information on auto switches.

Auto switch proper mounting position and its mounting height	P.141 to 145
Minimum stroke for auto switch mounting	
Operating range	
Auto switch mounting brackets/Part no.	

Weight

Weight

Action	Bore size (mm)	Cylinder stroke (mm)			
		5	10	15	20
Spring return	12	55	63	—	—
	16	92	100	—	—
	20	121	135	—	—
	25	178	191	—	—
	32	217	242	—	—
	40	323	349	—	—
Spring extend	12	61	69	—	—
	16	92	100	—	—
	20	126	140	—	—
	25	184	197	—	—
	32	228	253	—	—
	40	349	375	—	—
	50	—	600	—	683

Additional Weight

Rod end male thread	Bore size (mm)	12	16	20	25	32	40	50
	Male thread		1.5	3	6	12	26	27
Nut		1	2	4	8	17	17	32

Calculation: (Example) **CDQP2B32-10SM**

• Basic weight: CDQP2B32-10S 242 g

• Additional weight: Rod end male thread... 43 g
285 g

Add each weight of auto switches when auto switches are mounted.

Construction

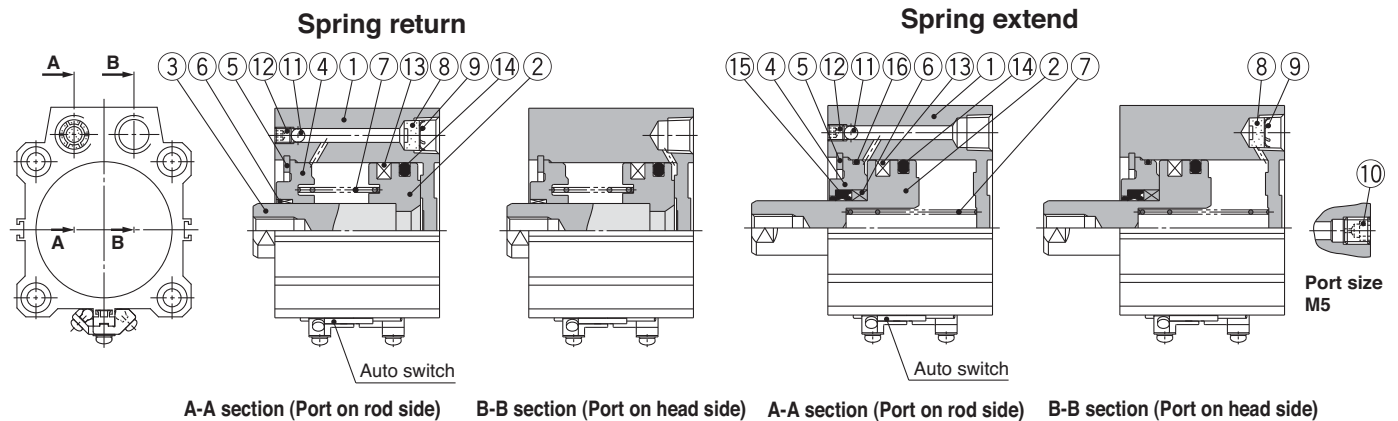

A-A section (Port on rod side) B-B section (Port on head side) A-A section (Port on rod side) B-B section (Port on head side)

Component Parts

No.	Description	Material	Note
1	Cylinder tube	Aluminum alloy	Hard anodised
2	Piston*	Aluminum alloy	Chromated
3	Piston rod*	Stainless steel	ø12 to ø25
		Carbon steel	ø32 to ø50, Hard chrome plated
4	Collar	Aluminum alloy	ø12 to ø40, Anodised
		Aluminum alloy casted	ø50, Chromate, Painted
5	Retaining ring	Carbon tool steel	Phosphate coated
6	Bushing	Bearing alloy	
7	Return spring	Piano wire	Zinc chromated
8	Bronze element	Sintered metallic BC	Port size Rc1/8, 1/4
9	Retaining ring	Carbon tool steel	
10	Plug with fixed orifice	Alloy steel	Port size M5
11	Steel ball	Carbon steel	
12	Hexagon socket head set screw	Alloy steel	Nickel plated
13	Magnet	—	
14	Piston seal	NBR	
15	Rod seal	NBR	
16	Gasket	NBR	

* On spring extend (Type T), piston and piston rod are integrated (stainless steel).

Replacement Parts/Seal Kit

Bore size (mm)	Kit no. (Single acting/Spring return)	Kit no. (Single acting/Spring extend)
12	CQ2B12-S-PS	CQ2B12-T-PS
16	CQ2B16-S-PS	CQ2B16-T-PS
20	CQ2B20-S-PS	CQ2B20-T-PS
25	CQ2B25-S-PS	CQ2B25-T-PS
32	CQ2B32-S-PS	CQ2B32-T-PS
40	CQ2B40-S-PS	CQ2B40-T-PS
50	CQ2B50-S-PS	CQ2B50-T-PS
Contents	Kits include item 14 from the table.	Kits include items 14, 15, 16 from the table.
How to Order	* Seal kit includes 14. Order the seal kit, based on each bore size.	* Seal kit includes 14, 15, 16. Order the seal kit, based on each bore size.

* Since the seal kit does not include a grease pack, order it separately.

Grease pack part no.: GR-S-010 (10 g)

Series CQP2

Mounting Bolt for CDQP2B/With Auto Switch

Mounting method: Mounting bolt for through-hole mounting of the CDQP2B is available as an option. Refer to the following for ordering procedures. Order the actual number of bolts that will be used.

Example) CQ-M3 x 35L 2 pcs.

Material: Chromium molybdenum steel
Surface treatment: Zinc chromated

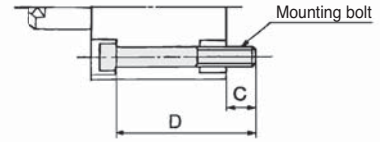
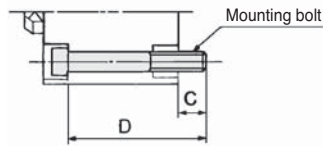

Spring Return

Cylinder model	C	D	Mounting bolt part no.
CDQP2B12-5S	5.5	35	CQ-M3 x 35L
-10S		40	x 40L
CDQP2B16-5S	8	40	CQ-M3 x 40L
-10S		45	x 45L
CDQP2B20-5S	10.5	40	CQ-M5 x 40L
-10S		45	x 45L
CDQP2B25-5S	9.5	40	CQ-M5 x 40L
-10S		45	x 45L
CDQP2B32-5S	9	40	CQ-M5 x 40L
-10S		45	x 45L
CDQP2B40-5S	7.5	45	CQ-M5 x 45L
-10S		50	x 50L
CDQP2B50-10S	12.5	55	CQ-M6 x 55L
-20S		60	x 60L

Spring Extend

Cylinder model	C	D	Mounting bolt part no.
CDQP2B12-5T	6.1	40	CQ-M3 x 40L
-10T		45	x 45L
CDQP2B16-5T	8	40	CQ-M3 x 40L
-10T		45	x 45L
CDQP2B20-5T	10.5	40	CQ-M5 x 40L
-10T		45	x 45L
CDQP2B25-5T	9.5	40	CQ-M5 x 40L
-10T		45	x 45L
CDQP2B32-5T	9	40	CQ-M5 x 40L
-10T		45	x 45L
CDQP2B40-5T	7.5	45	CQ-M5 x 45L
-10T		50	x 50L
CDQP2B50-10T	12.5	55	CQ-M6 x 55L
-20T		65	x 65L

Dimensions

∅12 to ∅50/Spring Return Without Auto Switch

∅12 to ∅25

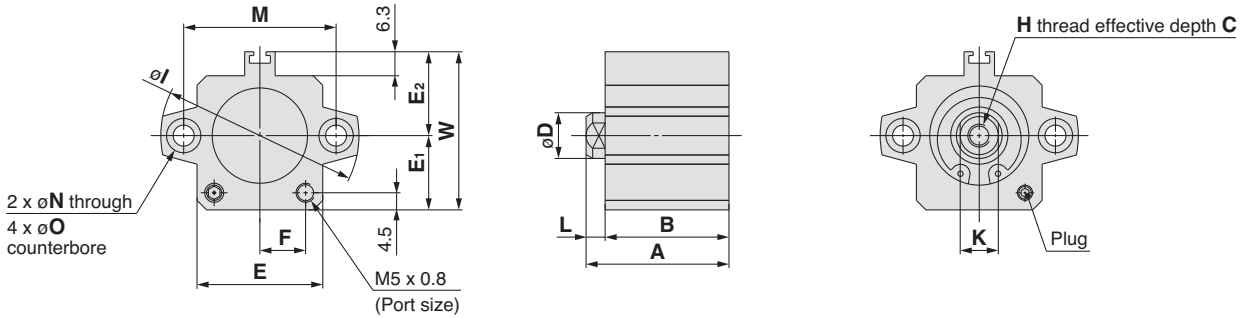

Rod end male thread

Width across flat B₁

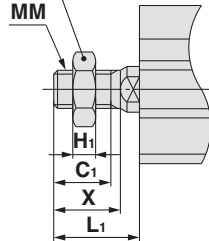

Rod End Male Thread

(mm)

Bore size (mm)	B ₁	C ₁	H ₁	L ₁	MM	X
12	8	9	4	14	M5 x 0.8	10.5
16	10	10	5	15.5	M6 x 1.0	12
20	13	12	5	18.5	M8 x 1.25	14
25	17	15	6	22.5	M10 x 1.25	17.5

Standard

(mm)

Bore size (mm)	A		B			C	D	E	E ₁	E ₂	F	H	I	K	L	M	N	O	W
	5st	10st	5st	10st	20st														
12	25.5	30.5	22	27	6	6	23	13	14	7	M3 x 0.5	32	5	3.5	22	3.5	6.5 depth 3.5	27	
16	27	32	23.5	28.5	8	8	26	15	17	8.5	M4 x 0.7	38	6	3.5	28	3.5	6.5 depth 3.5	32	
20	29	34	24.5	29.5	7	10	30	17	19	10.5	M5 x 0.8	47	8	4.5	36	5.5	9 depth 7	36	
25	32.5	37.5	27.5	32.5	12	12	33	19.5	22	12	M6 x 1.0	52	10	5	40	5.5	9 depth 7	41.5	

∅32 to ∅50

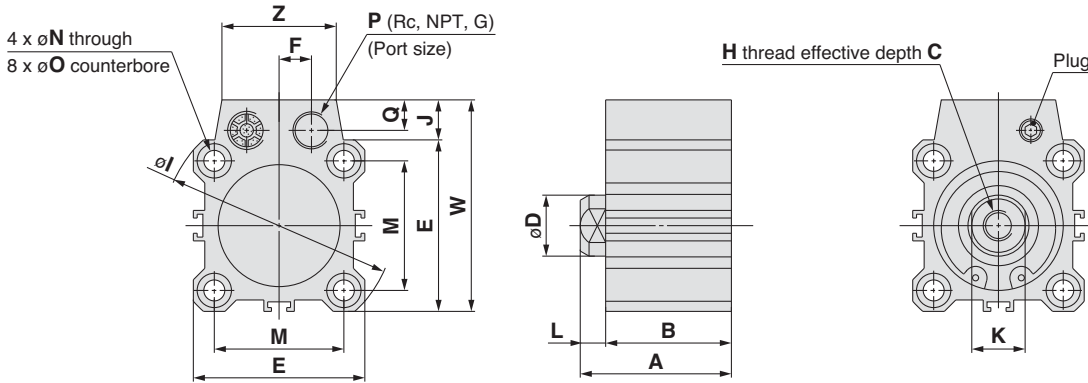

Rod end male thread

Width across flat B₁

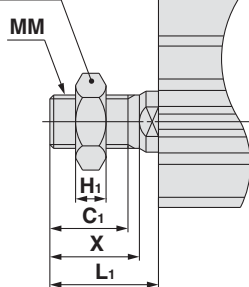

Rod End Male Thread

(mm)

Bore size (mm)	B ₁	C ₁	H ₁	L ₁	MM	X
32	22	20.5	8	28.5	M14 x 1.5	23.5
40	22	20.5	8	28.5	M14 x 1.5	23.5
50	27	26	11	33.5	M18 x 1.5	28.5

Standard

(mm)

Bore size (mm)	A			B			C	D	E	F	H	I	J	K	L	M	N	O	P	Q	W	Z
	5st	10st	20st	5st	10st	20st																
32	35	40	—	28	33	—	13	16	45	8.5	M8 x 1.25	60	10.5	14	7	34	5.5	9 depth 7	1/8	8	55.5	30
40	41.5	46.5	—	34.5	39.5	—	13	16	52	8.5	M8 x 1.25	69	10	14	7	40	5.5	9 depth 7	1/8	8	62	30
50	—	48.5	58.5	—	40.5	50.5	15	20	64	11	M10 x 1.5	86	13	17	8	50	6.6	11 depth 8	1/4	10	77	39

* For details about the rod end nut and accessory brackets, refer to page 23.

Standard
Large Bore Size
Long Stroke
Non-rotating Rod
Axial Piping
Anti-lateral Load
With End Lock
Water Resistant
With Auto Switch
Auto Switch
Made to Order

Series CQP2

Dimensions

Ø12 to Ø50/Spring Return With Auto Switch

Ø12 to Ø25

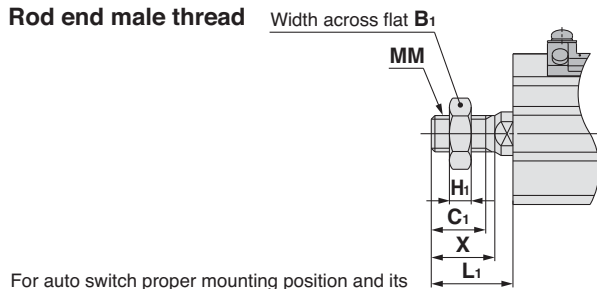
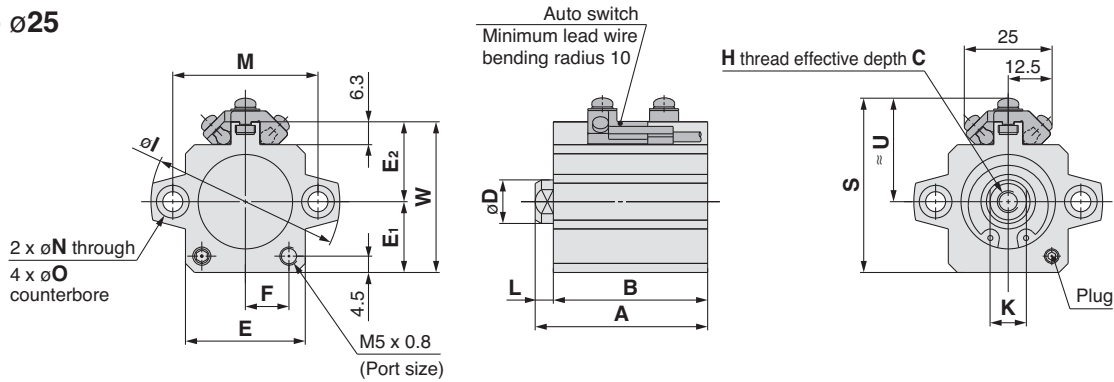

Rod End Male Thread (mm)

Bore size (mm)	B ₁	C ₁	H ₁	L ₁	MM	X
12	8	9	4	14	M5 x 0.8	10.5
16	10	10	5	15.5	M6 x 1.0	12
20	13	12	5	18.5	M8 x 1.25	14
25	17	15	6	22.5	M10 x 1.25	17.5

Standard For auto switch proper mounting position and its mounting height, refer to pages 141 to 145.

Bore size (mm)	A		B		C	D	E	E ₁	E ₂	F	H	I	K	L	M	N	O	S	U	W
	5st	10st	5st	10st																
12	36.5	41.5	33	38	6	6	23	13	14	7	M3 x 0.5	32	5	3.5	22	3.5	6.5 depth 3.5	33.5	20.5	27
16	39	44	35.5	40.5	8	8	26	15	17	8.5	M4 x 0.7	38	6	3.5	28	3.5	6.5 depth 3.5	38.5	23.5	32
20	41	46	36.5	41.5	7	10	30	17	19	10.5	M5 x 0.8	47	8	4.5	36	5.5	9 depth 7	42.5	25.5	36
25	42.5	47.5	37.5	42.5	12	12	33	19.5	22	12	M6 x 1.0	52	10	5	40	5.5	9 depth 7	48	28.5	41.5

Ø32 to Ø50

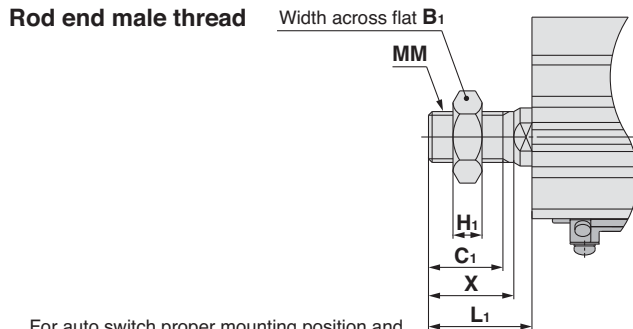
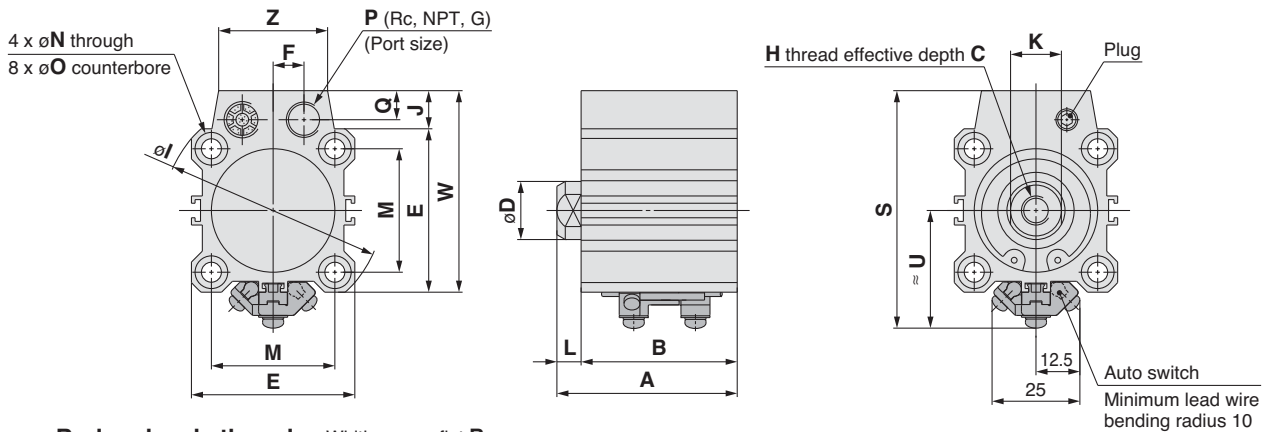

Rod End Male Thread (mm)

Bore size (mm)	B ₁	C ₁	H ₁	L ₁	MM	X
32	22	20.5	8	28.5	M14 x 1.5	23.5
40	22	20.5	8	28.5	M14 x 1.5	23.5
50	27	26	11	33.5	M18 x 1.5	28.5

Standard For auto switch proper mounting position and its mounting height, refer to pages 141 to 145.

Bore size (mm)	A			B			C	D	E	F	H	I	J	K	L	M	N	O	P	Q	S	U	W	Z
	5st	10st	20st	5st	10st	20st																		
32	45	50	—	38	43	—	13	16	45	8.5	M8 x 1.25	60	10.5	14	7	34	5.5	9 depth 7	1/8	8	65.5	32.5	55.5	30
40	51.5	56.5	—	44.5	49.5	—	13	16	52	8.5	M8 x 1.25	69	10	14	7	40	5.5	9 depth 7	1/8	8	72	36	62	30
50	—	58.5	68.5	—	50.5	60.5	15	20	64	11	M10 x 1.5	86	13	17	8	50	6.6	11 depth 8	1/4	10	87	42	77	39

* For details about the rod end nut and accessory brackets, refer to page 23.

Dimensions

ø12 to ø50/Spring Extend Without Auto Switch

ø12 to ø25

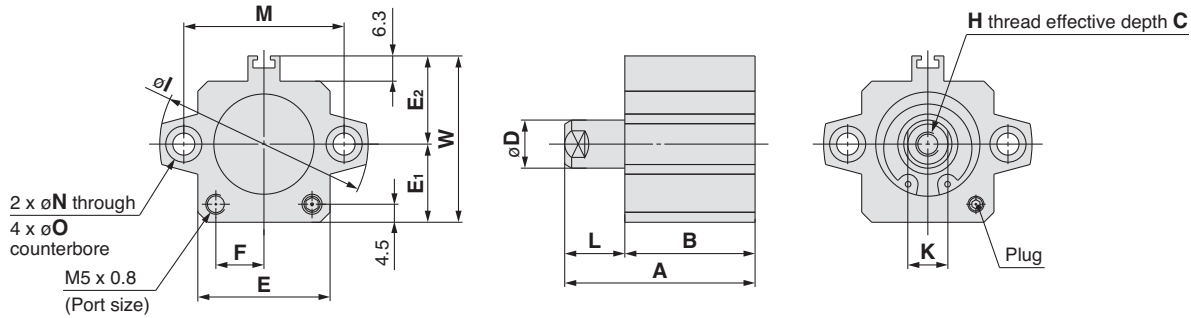

Rod end male thread

Width across flat B₁

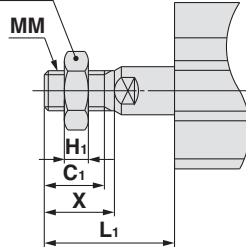

Rod End Male Thread

(mm)

Bore size (mm)	B ₁	C ₁	H ₁	L ₁		MM	X
				5st	10st		
12	8	9	4	19	24	M5 x 0.8	10.5
16	10	10	5	20.5	25.5	M6 x 1.0	12
20	13	12	5	23.5	28.5	M8 x 1.25	14
25	17	15	6	27.5	32.5	M10 x 1.25	17.5

Standard

(mm)

Bore size (mm)	A		B		C	D	E	E ₁	E ₂	F	H	I	K	L		M	N	O	W
	5st	10st	5st	10st										5st	10st				
12	30.5	40.5	22	27	6	6	23	13	14	7	M3 x 0.5	32	5	8.5	13.5	22	3.5	6.5 depth 3.5	27
16	32	42	23.5	28.5	8	8	26	15	17	8.5	M4 x 0.7	38	6	8.5	13.5	28	3.5	6.5 depth 3.5	32
20	34	44	24.5	29.5	7	10	30	17	19	10.5	M5 x 0.8	47	8	9.5	14.5	36	5.5	9 depth 7	36
25	37.5	47.5	27.5	32.5	12	12	33	19.5	22	12	M6 x 1.0	52	10	10	15	40	5.5	9 depth 7	41.5

ø32 to ø50

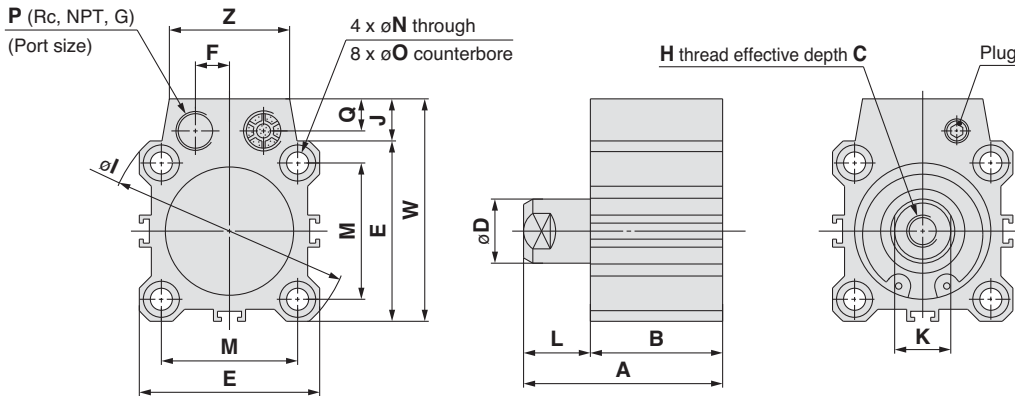

Rod end male thread

Width across flat B₁

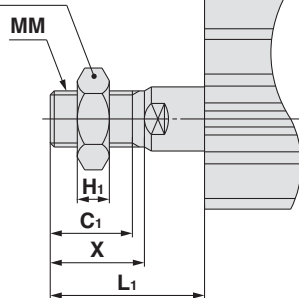

Rod End Male Thread

(mm)

Bore size (mm)	B ₁	C ₁	H ₁	L ₁			MM	X
				5st	10st	20st		
32	22	20.5	8	33.5	38.5	—	M14 x 1.5	23.5
40	22	20.5	8	33.5	38.5	—	M14 x 1.5	23.5
50	27	26	11	—	43.5	53.5	M18 x 1.5	28.5

Standard

(mm)

Bore size (mm)	A			B			C	D	E	F	H	I	J	K	L			M	N	O	P	Q	W	Z
	5st	10st	20st	5st	10st	20st									5st	10st	20st							
32	40	50	—	28	33	—	13	16	45	8.5	M8 x 1.25	60	10.5	14	12	17	—	34	5.5	9 depth 7	1/8	8	55.5	30
40	46.5	56.5	—	34.5	39.5	—	13	16	52	8.5	M8 x 1.25	69	10	14	12	17	—	40	5.5	9 depth 7	1/8	8	62	30
50	—	58.5	78.5	—	40.5	50.5	15	20	64	11	M10 x 1.5	86	13	17	—	18	28	50	6.6	11 depth 8	1/4	10	77	39

* For details about the rod end nut and accessory brackets, refer to page 23.

Standard

Large Bore Size

Long Stroke

Non-rotating Rod

Axial Piping

Anti-lateral Load

With End Lock

Water Resistant

With Auto Switch

Auto Switch

Made to Order

Series CQP2

Dimensions

Ø12 to Ø50/Spring Extend With Auto Switch

Ø12 to Ø25

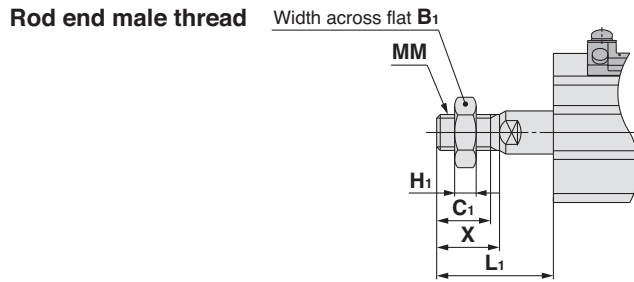
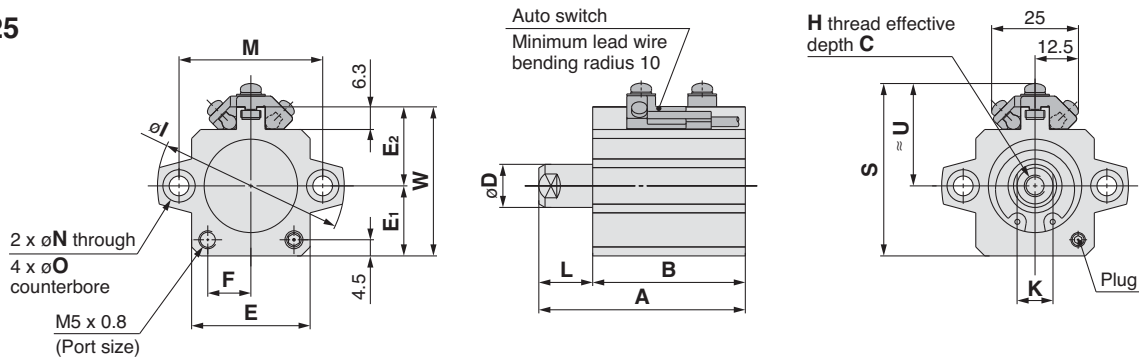

Rod End Male Thread (mm)

Bore size (mm)	B ₁	C ₁	H ₁	L ₁		MM	X
				5st	10st		
12	8	9	4	19	24	M5 x 0.8	10.5
16	10	10	5	20.5	25.5	M6 x 1.0	12
20	13	12	5	23.5	28.5	M8 x 1.25	14
25	17	15	6	27.5	32.5	M10 x 1.25	17.5

Standard For auto switch proper mounting position and its mounting height, refer to pages 141 to 145. (mm)

Bore size (mm)	A		B		C	D	E	E ₁	E ₂	F	H	I	K	L		M	N	O	S	U	W
	5st	10st	5st	10st										5st	10st						
12	45.9	55.9	37.4	42.4	6	6	23	13	14	7	M3 x 0.5	32	5	8.5	13.5	22	3.5	6.5 depth 3.5	33.5	20.5	27
16	44	54	35.5	40.5	8	8	26	15	17	8.5	M4 x 0.7	38	6	8.5	13.5	28	3.5	6.5 depth 3.5	38.5	23.5	32
20	46	56	36.5	41.5	7	10	30	17	19	10.5	M5 x 0.8	47	8	9.5	14.5	36	5.5	9 depth 7	42.5	25.5	36
25	47.5	57.5	37.5	42.5	12	12	33	19.5	22	12	M6 x 1.0	52	10	10	15	40	5.5	9 depth 7	48	28.5	41.5

Ø32 to Ø50

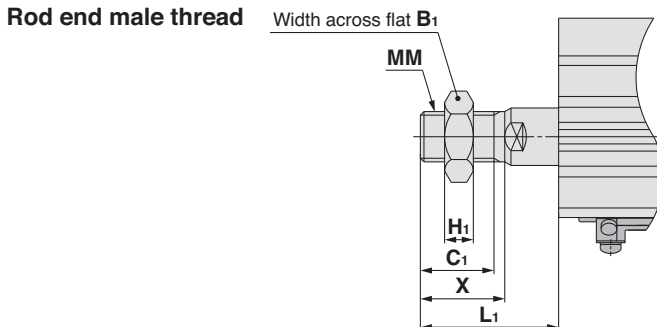
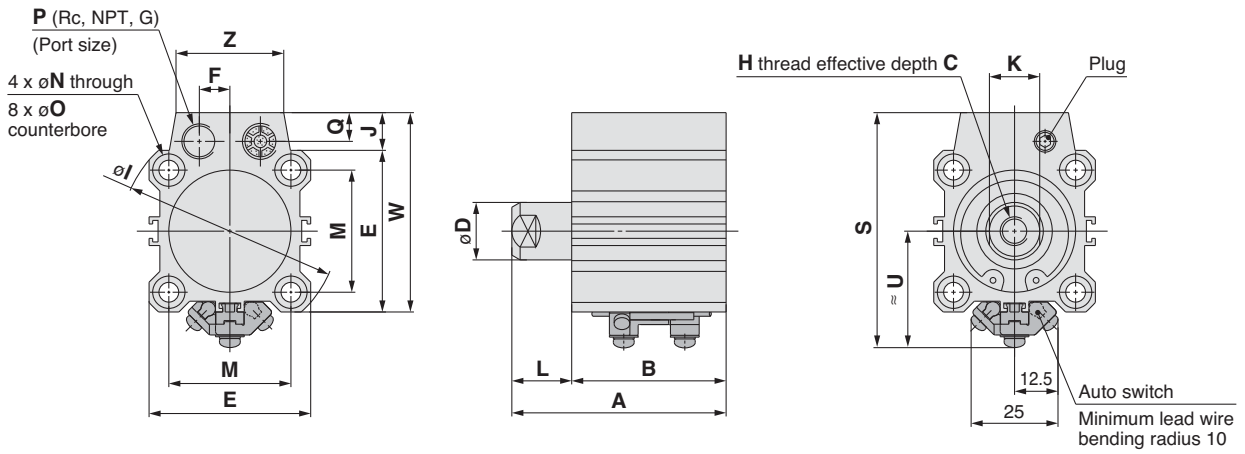

Rod End Male Thread (mm)

Bore size (mm)	B ₁	C ₁	H ₁	L ₁			MM	X
				5st	10st	20st		
32	22	20.5	8	33.5	38.5	—	M14 x 1.5	23.5
40	22	20.5	8	33.5	38.5	—	M14 x 1.5	23.5
50	27	26	11	—	43.5	53.5	M18 x 1.5	28.5

Standard For auto switch proper mounting position and its mounting height, refer to pages 141 to 145. (mm)

Bore size (mm)	A			B			C	D	E	F	H	I	J	K	L			M	N	O	P	Q	S	U	W	Z
	5st	10st	20st	5st	10st	20st									5st	10st	20st									
32	50	60	—	38	43	—	13	16	45	8.5	M8 x 1.25	60	10.5	14	12	17	—	34	5.5	9 depth 7	1/8	8	62	29	55.5	30
40	56.5	66.5	—	44.5	49.5	—	13	16	52	8.5	M8 x 1.25	69	10	14	12	17	—	40	5.5	9 depth 7	1/8	8	68.5	32.5	62	30
50	—	68.5	88.5	—	50.5	60.5	15	20	64	11	M10 x 1.5	86	13	17	—	18	28	50	6.6	11 depth 8	1/4	10	83.5	38.5	77	39

* For details about the rod end nut and accessory brackets, refer to page 23.

- Made to Order
- Auto Switch
- With Auto Switch
- Water Resistant
- With End Lock
- Anti-lateral Load
- Axial Piping
- Non-rotating Rod
- Long Stroke
- Large Bore Size
- Standard

Axial Piping Series **CDQP2** With Auto Switch 1

1 Auto Switch Proper Mounting Position (Detection at Stroke End) and its Mounting Height

Applicable Cylinder Series: CDQP2, CDQP2□□□□-□S/-□T (Axial piping)

- D-A9□
- D-M9□
- D-M9□W
- D-M9□AL
- D-A9□V
- D-M9□V
- D-M9□WV
- D-M9□AVL

ø12 to ø25

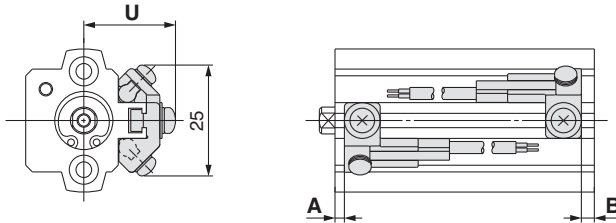

ø32 to ø100

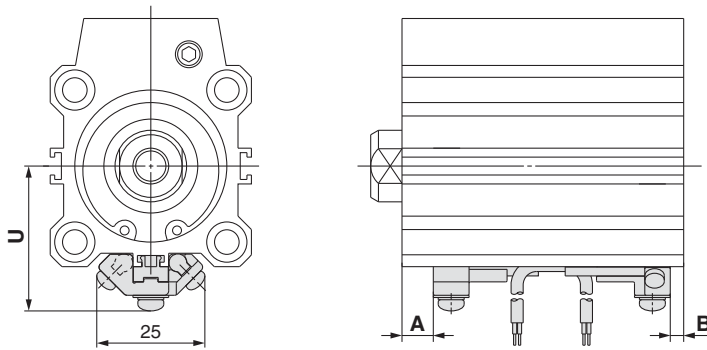

- D-A7□
- D-A80
- D-A7□H
- D-A80H
- D-F7□
- D-J79
- D-F7□W
- D-J79W
- D-F79F

- D-F7NTL
- D-F7BAL
- D-A73C
- D-A80C
- D-J79C
- D-A79W
- D-F7□WV
- D-F7□V
- D-F7BAVL

ø12 to ø25

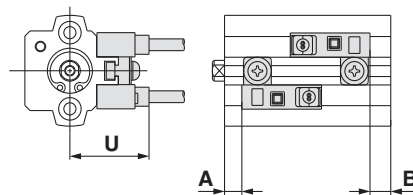

ø32 to ø100

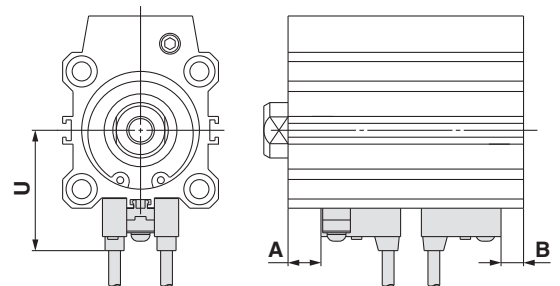

D-P4DWL

ø40 to ø100

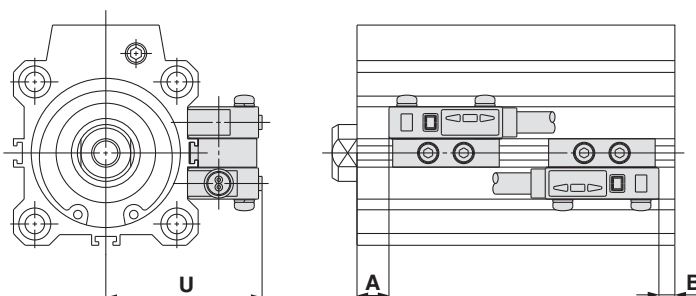

Auto Switch Proper Mounting Position

Applicable Cylinder Series: CDQP2 (Axial piping)

(mm)

Auto switch model	D-A9□ D-A9□V		D-M9□ D-M9□V D-M9□W D-M9□WV D-M9□A D-M9□AV		D-A73 D-A80		D-A72/A7□H/A80H D-A73C/A80C/F7□ D-F79F/J79/F7□V D-J79C/F7□W D-J79W/F7□WV D-F7BAV/F7BA		D-F7NT		D-A79W		D-P4DW	
	A	B	A	B	A	B	A	B	A	B	A	B	A	B
Bore size														
12	2	3	6	7	4.5	5.5	5	6	10	11	2	3	—	—
16	5	2.5	9	6.5	7.5	5	8	5.5	13	10.5	5	2.5	—	—
20	5	3.5	9	7.5	7.5	6.5	8	7	13	12	5	4	—	—
25	5.5	4	9.5	8	7.5	7	8	7.5	13	12.5	5	4.5	—	—
32	6.5	3.5	10.5	7.5	9	6	9.5	6.5	14.5	11.5	6.5	3.5	—	—
40	10.5	6	14.5	10	13	8.5	13.5	9	18.5	14	10.5	6	9	4.5
50	8.5	9	12.5	13	11	11.5	11.5	12	16.5	17	8.5	9	7	7.5
63	11	12	15	16	13.5	14.5	14	15	19	20	11	12	9.5	10.5
80	14	16.5	18	20.5	17.5	18	18	18.5	23	23.5	15	15.5	13.5	14
100	18.5	21.5	22.5	25.5	21	24	21.5	24.5	26.5	29.5	18.5	21.5	17	20

Note) Adjust the auto switch after confirming the operating conditions in the actual setting.

Applicable Cylinder Series: CDQP2□□□-□S/□T (Axial piping, Single acting)

(mm)

Auto switch model	D-A9□ D-A9□V		D-M9□ D-M9□V D-M9□W D-M9□WV D-M9□A D-M9□AV		D-A73 D-A80		D-A72/A7□H/A80H D-A73C/A80C/F7□ D-F79F/J79/F7□V D-J79C/F7□W D-J79W/F7□WV D-F7BAV/F7BA		D-F7NT		D-A79W	
	A	B	A	B	A	B	A	B	A	B	A	B
Bore size												
12	2	3 (7)	6	7 (11)	4.5	5.5 (10)	5	6 (10.5)	10	11 (15.5)	2	3 (7.5)
16	5 (3)	2.5 (4.5)	9 (7)	6.5 (8.5)	7.5 (5.5)	5 (7)	8 (6)	5.5 (7.5)	13 (11)	10.5 (12.5)	5 (3)	2.5 (4.5)
20	5	3.5	9	7.5	7.5	6.5	8	7	13	12	5	4
25	5.5	4	9.5	8	7.5	7	8	7.5	13	12.5	5	4.5
32	6.5	3.5	10.5	7.5	9	6	9.5	6.5	14.5	11.5	6.5	3.5
40	10.5	6	14.5	10	13	8.5	13.5	9	18.5	14	10.5	6
50	8.5	9	12.5	13	11	11.5	11.5	12	16.5	17	8.5	9

(): Spring extend type

Note) Adjust the auto switch after confirming the operating conditions in the actual setting.

Applicable Cylinder Series: CDQP2, CDQP2□□□-□S/□T (Axial piping)

(mm)

Auto switch model	D-A9□ D-A9□V D-M9□ D-M9□V D-M9□W D-M9□WV D-M9□A D-M9□AV		D-A7□ D-A80		D-A7□H D-A80H D-F7□ D-J79 D-F7□W D-J79W D-F7BA D-F79F D-F7NT		D-A73C D-A80C		D-F7□V D-F7□WV D-F7BAV		D-J79C		D-A79W		D-P4DW	
	U	U	U	U	U	U	U	U	U	U	U	U	U	U	U	
Bore size																
12	20.5	19.5	20.5	26.5	23	26	22	—								
16	23.5	22.5	23.5	29.5	26	29	25	—								
20	25.5	24.5	25.5	31.5	28	31	27	—								
25	28.5	27.5	28.5	34.5	31	34	30	—								
32	32.5	31.5	32.5	38.5	35	38	34	—								
40	36	35	36	42	38.5	41.5	37.5	44								
50	42	41	42	48	44.5	47.5	43.5	50								
63	48.5	47.5	48.5	54.5	51	54	50	56.5								
80	58.5	57.5	58.5	64.5	61	64	60	66.5								
100	68.5	67.5	68.5	74.5	71	74	70	76.5								

Note) The applicable auto switches for the CDQP2□□□-□S/□T (single acting) are those except for the D-P4DW type.

Standard

Large Bore Size

Long Stroke

Non-rotating Rod

Axial Piping

Anti-lateral Load

With End Lock

Water Resistant

With Auto Switch

Auto Switch

Made to Order

Axial Piping Series CDQP2 With Auto Switch 2

2 Minimum Stroke for Auto Switch Mounting

Applicable Cylinder Series: CDQP2, CDQP2□□□-□S/-□T (Axial piping)

(mm)

Number of auto switches	D-M9□V D-F7□V D-J79C	D-A9□V D-A7□ D-A80 D-A73C D-A80C	D-A9□	D-M9□WV D-M9□AVL D-F7□WV D-F7BAVL	D-M9□ D-M9□W D-M9□AL D-A7□H D-A80H D-F7□ D-J79	D-A79W	D-F7□W D-J79W D-F7BAL D-F79F D-F7NTL	D-P4DWL
With 1 pc.	5	5	10	10	15	15	20	15
With 2 pcs.	5	10	10	15	15	20	20	15

Note) The dimension stated in () shows the minimum stroke for the auto switch mounting when the auto switch does not project from the end surface of the cylinder body and hinder the lead wire bending space. (Refer to the figure below.)
The auto switch and auto switch mounting bracket are ordered separately.

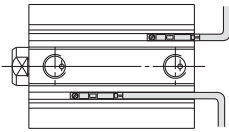

Note) The applicable auto switches for the CDQP2□□□-□S/-□T (single acting) are those except for the D-P4DW type.

3 Operating Range

Applicable Cylinder Series: CDQP2, CDQP2□□□-□S/-□T (Axial piping)

(mm)

Auto switch model	Bore size									
	12	16	20	25	32	40	50	63	80	100
D-A9□(V)	7.5	9.5	9	9	9.5	9.5	8.5	11	10	10.5
D-M9□(V) D-M9□W(V) D-M9□A(V)	3.5	5	5	5	5.5	5.5	6	6.5	7	7
D-A7□(H)(C) D-A80□(H)(C)	10	12	12	12	12	11	10	12	12	13
D-A79W	13	13	13	13	13	14	14	16	15	17
D-F7□(V) D-J79(C) D-F7□W(V) D-F7BA(V) D-F7NT D-F79F	5.5	6	5.5	5	6	6	6	6.5	6.5	7
D-P4DWL	—	—	—	—	—	5	5	5	5	5.5

* Values which include hysteresis are for guideline purposes only, they are not a guarantee (assuming approximately ±30% dispersion) and may change substantially depending on the ambient environment.

Note) The applicable auto switches for the CDQP2□□□-□S/-□T (single acting) are those except for the D-P4DW type.

4 Auto Switch Mounting Brackets/Part No.

Applicable Cylinder Series: CDQP2, CDQP2□□□-□S/-□T (Axial piping)

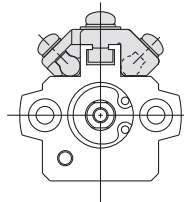
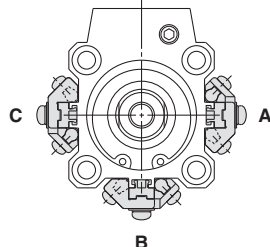
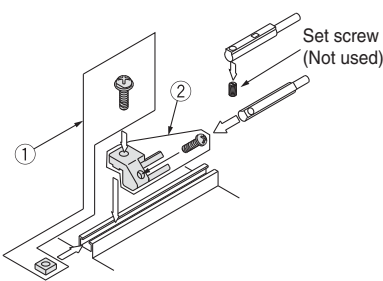
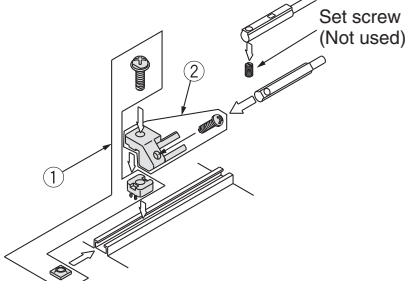
Auto switch mounting surface	Bore size (mm)	
	ø12, ø16, ø20, ø25	ø32 to ø100
		
Auto switch model	Auto switch mounting surface Auto switch mounting rail side only	Auto switch mounting surface A/B/C side
D-A9□ D-A9□V D-M9□ D-M9□V D-M9□W D-M9□WV D-M9□AL D-M9□AVL	① BQ-1 ② BQ2-012 Two kinds of auto switch brackets are used as a set. 	① BQ-2 ② BQ2-012 Two kinds of auto switch brackets are used as a set. 

Note 1) When shipping cylinders, auto switch mounting brackets and auto switches are shipped together.

Auto switch model	Bore size (mm)		
	ø12 to ø25	ø32	ø40 to ø100
D-A7□/A80 D-A73C/A80C D-A7□H/A80H D-A79W D-F7□/J79 D-F7□V D-J79C D-F7□W/J79W D-F7□WV D-F7BAL/F7BAVL D-F79F/F7NTL	BQ-1		BQ-2
D-P4DWL	—		BQP1-050

Note 2) When shipping cylinders, auto switch mounting brackets and auto switches are shipped together.

However, when the D-P4DWL type with ø40 to ø100 is mounted, the auto switch is assembled at the time of shipment.

Note 3) Refer to pages 1360 to 1362 in Best Pneumatics No. 2 for further information on auto switch mounting method.

[Stainless Steel Mounting Screw Kit]

The following stainless steel mounting screw kit (with nuts) is available. Use it in accordance with the operating environment. (Since auto switch spacer (for BQ-2) is not included, order BQ-2 separately.)

BBA2: For D-A7/A8/F7/J7 types

The above stainless steel screws are used when a cylinder is shipped with the D-F7BAL/F7BAVL auto switches.

When only an auto switch is shipped independently, BBA2 is attached.

Note 4) Refer to page 1361 in Best Pneumatics No. 2 for details of BBA2.

Note 5) When the D-M9□A(V)L type is mounted, order auto switch mounting brackets BQ2-012S, BQ-2 or the stainless steel mounting screw kit BBA2 separately.

Auto Switch Mounting Bracket/Weight

Mounting bracket part no.	Applicable bore size	Weight (g)
BQ-1	ø12 to ø25	1.5
BQ-2	ø32 to ø100	1.5
BQ2-012	ø12 to ø25	5
BQP1-050	ø40 to ø100	16

Standard

Large Bore Size

Long Stroke

Non-rotating Rod

Axial Piping

Anti-lateral Load

With End Lock

Water Resistant

With Auto Switch

Auto Switch

Made to Order

Axial Piping

Series **CDQP2**

With Auto Switch 3

Other than the applicable auto switches listed in “How to Order”, the following auto switches are mountable. Refer to Best Pneumatics No. 2 for detailed specifications.

Applicable Cylinder Series: CDQP2, CDQP2□□□-□S/-□T (Axial piping)

Auto switch type	Model	Electrical entry	Features	Applicable bore size
Reed	D-A73	Grommet (Perpendicular)	—	ø12 to ø100
	D-A80		Without indicator light	
	D-A73H, A76H	Grommet (In-line)	—	
	D-A80H		Without indicator light	
Solid state	D-F7NV, F7PV, F7BV	Grommet (Perpendicular)	—	ø12 to ø100
	D-F7NWV, F7BWV		Diagnostic indication (2-colour indication)	
	D-F7BAVL		Water resistant (2-colour indication)	
	D-F79, F7P, J79	Grommet (In-line)	—	
	D-F79W, F7PW, J79W		Diagnostic indication (2-colour indication)	
	D-F7BAL		Water resistant (2-colour indication)	
	D-F7NTL		With timer	
	D-P5DWL		Grommet (In-line)	

- * With pre-wired connector is also available for solid state auto switches. For details, refer to pages 1626 and 1627.
- * Normally closed (NC = b contact) solid state auto switches (D-F9G/F9H) are also available. For details, refer to page 1577.
- * The applicable auto switches for the CDQP2□□□-□S/-□T (single acting) are those except for the D-P4DW type.
- * When using a magnetic field resistant solid state auto switch D-P3DW type, please contact SMC separately. (Applicable bore size: ø32 to ø100)
- * Heat resistant solid state auto switch (D-F7NJ) is not applicable.
- * Regarding the D-P5DW, please contact SMC separately.

Compact Cylinder: Anti-lateral Load Series CQ2

ø32, ø40, ø50, ø63, ø80, ø100

How to Order

Without auto switch

CQ2 **B** **S** **32** **—** **30** **D** **—** **C** **—** **Z** **—**

With auto switch

CDQ2 **B** **S** **32** **—** **30** **D** **—** **C** **—** **Z** **—** **M9BW** **—** **—**

With auto switch
(Built-in magnet)

Mounting

B	Through-hole (Standard)
A	Both ends tapped
L	Foot
LC	Compact foot
F	Rod flange
G	Head flange
D	Double clevis

* Mounting brackets are shipped together, (but not assembled).
* Cylinder mounting bolts are not included. Order them separately referring to "Mounting Bolt for C(D)Q2BS" on pages 151 and 152.

Type

S	Anti-lateral load
----------	-------------------

Bore size

32	32 mm
40	40 mm
50	50 mm
63	63 mm
80	80 mm
100	100 mm

Port thread type

—	Rc
TN	NPT
TF	G

Cylinder stroke (mm)

Refer to the next page for standard strokes.

Action

D	Double acting
----------	---------------

Made to Order
Refer to the next page for details.

Number of auto switches

—	2 pcs.
S	1 pc.
n	"n" pcs.

Auto switch

—	Without auto switch
----------	---------------------

* Refer to the below table for applicable auto switches.

Auto switch mounting groove

Z	4 surfaces
----------	------------

Body option 2

—	Standard (Rod end female thread)
M	Rod end male thread

Cushion

C	Rubber bumper
----------	---------------

Body option 1

—	Standard
F	With boss on head end

Built-in Magnet Cylinder Model

If a built-in magnet cylinder without an auto switch is required, there is no need to enter the symbol for the auto switch.
(Example) CDQ2LS40-30DCZ

Refer to pages 1263 to 1371 in Best Pneumatics No. 2 for further information on auto switches.

Applicable Auto Switches

Refer to the individual catalogue (ES20-201) for the D-P3DW type.

Type	Special function	Electrical entry	Indicator light	Wiring (Output)	Load voltage		Auto switch model		Lead wire length (m)					Pre-wired connector	Applicable load				
					DC	AC	Perpendicular	In-line	0.5 (—)	1 (M)	3 (L)	5 (Z)	None (N)		Relay, PLC	IC circuit			
Solid state auto switch	—	Grommet	Yes	3-wire (NPN)	24 V	5 V, 12 V	—	M9NV	M9N	●	●	●	○	—			○	Relay, PLC	IC circuit
				3-wire (PNP)				M9PV	M9P	●	●	●	○	—	○				
				2-wire				M9BV	M9B	●	●	●	○	—	○				
				3-wire (NPN)				M9NWV	M9NW	●	●	●	○	—	○				
	Diagnostic indication (2-colour indication)			3-wire (PNP)				M9PWV	M9PW	●	●	●	○	—	○	—	○		
				2-wire				M9BWW	M9BW	●	●	●	○	—	○	—	○		
				3-wire (NPN)				M9NAV**	M9NA**	○	○	●	○	—	○	—	○		
	Water resistant (2-colour indication)			3-wire (PNP)				M9PAV**	M9PA**	○	○	●	○	—	○	—	○		
				2-wire				M9BAV**	M9BA**	○	○	●	○	—	○	—	○		
				2-wire (Non-polar)				—	P3DW	●	—	●	●	—	○	—	○		
Reed auto switch	—	Grommet	Yes	3-wire (NPN equivalent)	24 V	5 V, 12 V	100 V or less	A96V	A96	●	—	●	—	—	—	—	IC circuit		
				A93V				A93	●	—	●	—	—	—	—	—	Relay, PLC		
				A90V				A90	●	—	●	—	—	—	—	—	—	IC circuit	

* * Water resistant type auto switches can be mounted on the above models, but in such case SMC cannot guarantee water resistance. Consult with SMC regarding water resistant types with the above model numbers.

* Lead wire length symbols: 0.5 m — (Example) M9NW
1 m M (Example) M9NWM
3 m L (Example) M9NLW
5 m Z (Example) M9NZW

* Solid state auto switches marked with "○" are produced upon receipt of order.

* There are other applicable auto switches other than the listed above. For details, refer to page 199.

* For details about auto switches with pre-wired connector, refer to pages 1328 and 1329 in Best Pneumatics No. 2.

Series CQ2

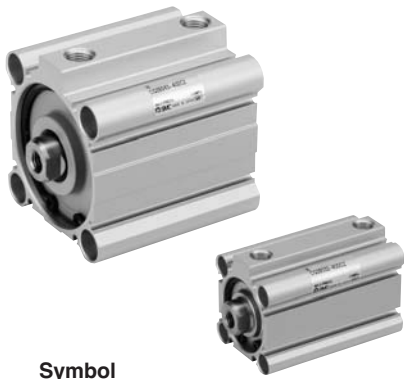

Symbol

Double acting,
Single rod

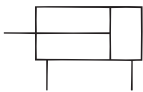

Made to Order

(For details, refer to pages 201 to 235.)

Symbol	Specifications
-XA□	Change of rod end shape
-XB10	Intermediate stroke (Exclusive body type)
-XC6	Piston rod/Retaining ring/Rod end nut material: Stainless steel
-XC26	With split pins for double clevis pin/ double knuckle joint pin and flat washers
-XC27	Double clevis pin/Double knuckle joint pin material: Stainless steel 304
-XC85	Grease for food processing equipment
-X271	Fluororubber seals

Retaining Ring Installation/Removal

⚠ Caution

- For installation and removal, use an appropriate pair of pliers (tool for installing a type C retaining ring).
- Even if a proper plier (tool for installing a type C retaining ring) is used, it is likely to inflict damage to a human body or peripheral equipment, as a retaining ring may be flown out of the tip of a plier (tool for installing a type C retaining ring). Be much careful with the popping of a retaining ring. Besides, be certain that a retaining ring is placed firmly into the groove of rod cover before supplying air at the time of installment.

Specifications

Bore size (mm)	32	40	50	63	80	100
Action	Double acting, Single rod					
Fluid	Air					
Proof pressure	1.5 MPa					
Maximum operating pressure	1.0 MPa					
Minimum operating pressure	0.05 MPa					
Ambient and fluid temperature	Without auto switch: -10 to 70°C (No freezing) With auto switch: -10 to 60°C (No freezing)					
Lubrication	Not required (Non-lube)					
Piston speed	50 to 500 mm/s					
Allowable kinetic energy (J)	0.29	0.52	0.91	1.54	2.71	4.54
Stroke length tolerance	+1.0 mm Note) 0					

Note) Stroke length tolerance does not include the amount of dumper change.

Standard Strokes

Bore size	Standard stroke (mm)
32, 40	5, 10, 15, 20, 25, 30, 35, 40, 45, 50, 75, 100
50, 63, 80, 100	10, 15, 20, 25, 30, 35, 40, 45, 50, 75, 100

Manufacture of Intermediate Strokes

Type	A spacer is installed in the standard stroke body.	Exclusive body (-XB10)		
Part no.	Refer to "How to Order" for the standard model number. (P. 146)	Suffix "-XB10" to the end of standard model number. (P. 146)		
Description	Strokes in 1 mm intervals are available by installing a spacer in the standard stroke cylinder.	Strokes in 1 mm intervals are available by using an exclusive body with the specified stroke.		
Stroke range	Bore size	Stroke range	Bore size	Stroke range
	32 to 100	1 to 99	32, 40	6 to 99
			50 to 100	11 to 99
Example	Part no.: CQ2BS50-57DCZ CQ2BS50-75DCZ with 18 mm width spacer inside The B dimension is 125.5 mm.	Part no.: CQ2BS50-57DCZ-XB10 Makes 57 stroke tube. The B dimension is 107.5 mm.		

- In the case of exclusive body type with $\phi 32$ to $\phi 100$ (-XB10) with the stroke length exceeding 50 mm, reference values of the longitudinal dimension will be changed. Calculate length dimensions by deducting from those of 75 or 100 mm stroke models.

Type

		Bore size (mm)	32	40	50	63	80	100
Pneumatic	Mounting	Through-hole (Standard)	●	●	●	●	●	●
		Both ends tapped	●	●	●	●	●	●
	Built-in magnet		●	●	●	●	●	●
	Piping	Pipe thread	Rc1/8	Rc1/8	Rc1/4	Rc1/4	Rc3/8	Rc3/8
			NPT1/8	NPT1/8	NPT1/4	NPT1/4	NPT3/8	NPT3/8
			G1/8	G1/8	G1/4	G1/4	G3/8	G3/8
	Rod end male thread		●	●	●	●	●	●
	With rubber bumper (Standard)		●	●	●	●	●	●
	With boss on head end		●	●	●	●	●	●

Refer to pages 193 to 199 for the specifications of cylinders with autoswitches.

- Auto switch proper mounting position (detection at stroke end) and its mounting height
- Minimum stroke for auto switch mounting
- Operating range
- Auto switch mounting brackets/Part no.

Copper and Fluorine-free Series (For CRT Manufacturing Process)

20-CQ2BS Bore size — Stroke DC(M)Z

Copper and fluorine-free series

∅32, ∅40, ∅50, ∅63
∅80, ∅100

For preventing the influence of copper ions or halogen ions during CRT manufacturing processes, copper and fluorine materials are not used in the component parts.

Specifications

Bore size (mm)	32	40	50	63	80	100
Action	Double acting, Single rod					
Proof pressure	1.5 MPa					
Max. operating pressure	1.0 MPa					
Rubber bumper	With (Standard)					
Piping	Pipe thread					
Piston speed	50 to 500 mm/s					
Mounting	Through-hole/Both ends tapped					
Auto switch	Mountable					

Theoretical Output

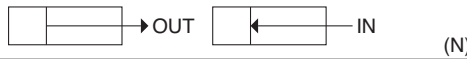

Bore size (mm)	Operating direction	Operating pressure (MPa)		
		0.3	0.5	0.7
32	IN	181	302	422
	OUT	241	402	563
40	IN	317	528	739
	OUT	377	628	880
50	IN	495	825	1155
	OUT	589	982	1374
63	IN	841	1402	1962
	OUT	935	1559	2182
80	IN	1361	2268	3175
	OUT	1508	2513	3519
100	IN	2144	3574	5003
	OUT	2356	3927	5498

Weight

Weight

Bore size (mm)	Cylinder stroke (mm)											
	5	10	15	20	25	30	35	40	45	50	75	100
32	134	154	174	193	213	233	252	272	291	311	457	556
40	211	232	254	275	297	318	340	361	383	404	577	689
50	—	369	402	435	467	500	533	566	598	632	902	1073
63	—	557	595	633	671	709	747	786	824	862	1189	1386
80	—	983	1043	1104	1164	1224	1284	1345	1405	1465	1985	2281
100	—	1711	1792	1872	1952	2033	2113	2194	2274	2354	3086	3494

Additional Weight

Bore size (mm)	32	40	50	63	80	100
Both ends tapped	6	6	6	19	45	45
Rod end male thread	Male thread	26	27	53	53	120
	Nut	17	17	32	32	49
Foot (Including mounting bolts)	142	154	243	320	690	1057
Compact foot (Including mounting bolts)	99	114	177	241	501	770
Rod flange (Including mounting bolts)	180	214	373	559	1056	1365
Head flange (Including mounting bolts)	165	198	348	534	1017	1309
Double clevis (Including pin, retaining rings, bolts)	151	196	393	554	1109	1887

Calculation: (Example) **CQ2DS32-20DCMZ**

- Basic weight: CQ2BS32-20DCZ 193 g
 - Additional weight: Both ends tapped 6 g
 - Rod end male thread 43 g
 - Double clevis 151 g
- 393 g

Allowable Lateral Load at Rod End

Without Auto Switch

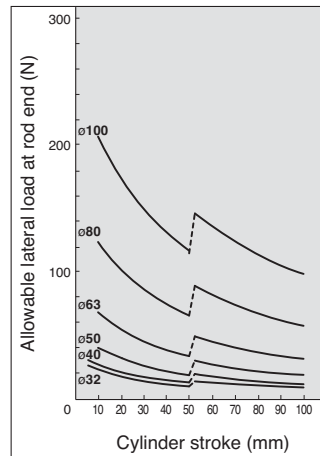

With Auto Switch

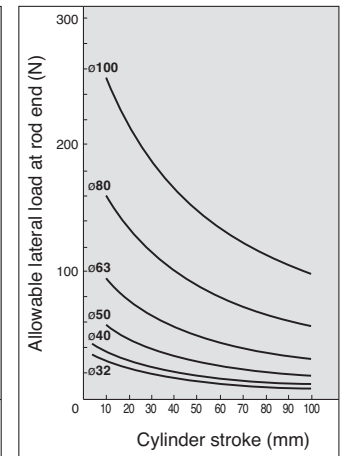

Standard

Large Bore Size

Long Stroke

Non-rotating Rod

Axial Piping

Anti-lateral Load

With End Lock

Water Resistant

With Auto Switch

Auto Switch

Made to Order

Series CQ2

Construction

Standard

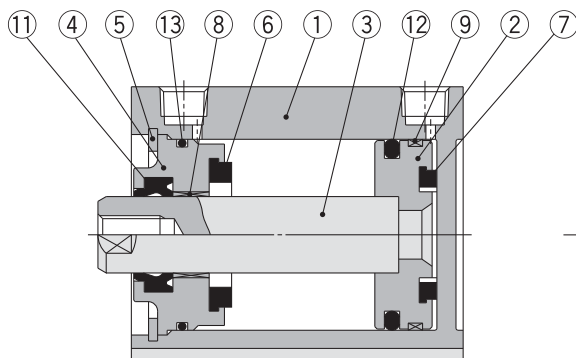

Rod end male thread

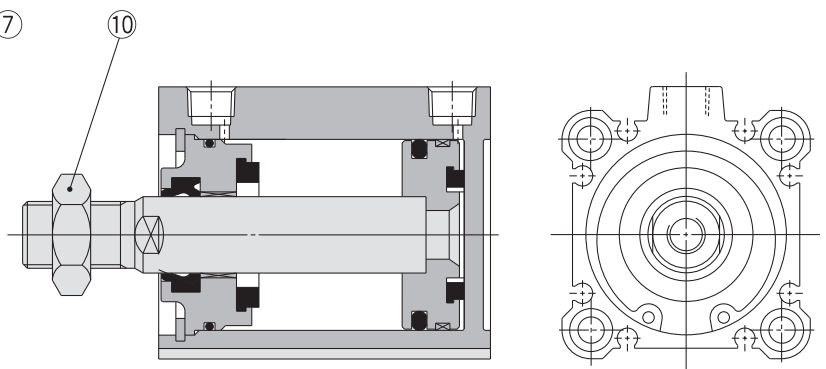

Component Parts

No.	Description	Material	Note
1	Cylinder tube	Aluminum alloy	Hard anodised
2	Piston	Aluminum alloy	Chromated
3	Piston rod	Carbon steel	Hard chrome plated
4	Collar	Aluminum alloy	Anodised
5	Retaining ring	Carbon tool steel	Phosphate coated
6	Bumper A	Urethane	
7	Bumper B	Urethane	
8	Bushing	Bearing alloy	
9	Wear ring	Resin	
10	Rod end nut	Carbon steel	Nickel plated
11	Rod seal	NBR	
12	Piston seal	NBR	
13	Tube gasket	NBR	

Replacement Parts/Seal Kit

Bore size (mm)	Kit no.	Contents
32	CQ2B32-PS	Kits include items ⑪, ⑫, ⑬ from the table.
40	CQ2B40-PS	
50	CQ2B50-PS	
63	CQ2B63-PS	
80	CQ2B80-PS	
100	CQ2B100-PS	

* Seal kit includes ⑪, ⑫, ⑬. Order the seal kit based on each bore size.

* Since the seal kit does not include a grease pack, order it separately.

Grease pack part no.: GR-S-010 (10 g)

Mounting Brackets/Part No.

Bore size (mm)	Foot <small>Note 1)</small>	Compact Foot <small>Note 1)</small>	Flange	Double clevis
32	CQ-L032	CQ-LC032	CQ-F032	CQ-D032
40	CQ-L040	CQ-LC040	CQ-F040	CQ-D040
50	CQ-L050	CQ-LC050	CQ-F050	CQ-D050
63	CQ-L063	CQ-LC063	CQ-F063	CQ-D063
80	CQ-L080	CQ-LC080	CQ-F080	CQ-D080
100	CQ-L100	CQ-LC100	CQ-F100	CQ-D100



Note 1) When ordering a foot and compact foot brackets, order 2 pieces per cylinder.

Note 2) Parts belonging to each bracket are as follows.
 Foot, Compact foot, Flange: Body mounting bolts
 Double clevis: Clevis pin, Type C retaining rings for axis, Body mounting bolts.

Anti-lateral Load Series CDQ2 With Auto Switch

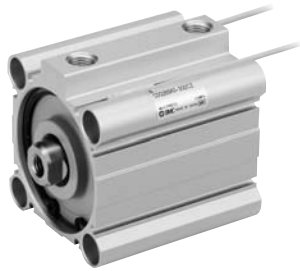

Refer to the below pages for further information on auto switches.

Auto switch proper mounting position and its mounting height	P.193 to 199
Minimum stroke for auto switch mounting	
Operating range	
Auto switch mounting brackets/Part no.	

Weight

Weight

(g)

Bore size (mm)	Cylinder stroke (mm)											
	5	10	15	20	25	30	35	40	45	50	75	100
32	191	211	230	250	270	289	309	329	348	368	468	567
40	284	305	327	348	369	391	412	434	455	477	589	701
50	—	480	513	546	579	611	644	677	710	743	915	1087
63	—	710	748	787	825	863	901	939	977	1015	1211	1408
80	—	1229	1289	1350	1410	1470	1530	1591	1651	1711	2008	2305
100	—	2070	2150	2231	2311	2391	2472	2552	2633	2713	3121	3529

Additional Weight

(g)

Bore size (mm)	32	40	50	63	80	100
Both ends tapped	6	6	6	19	45	45
Rod end male thread	Male thread	26	27	53	53	120
	Nut	17	17	32	32	49
Foot (Including mounting bolts)	142	154	243	320	690	1057
Compact foot (Including mounting bolts)	99	114	177	241	501	770
Rod flange (Including mounting bolts)	180	214	373	559	1056	1365
Head flange (Including mounting bolts)	165	198	348	534	1017	1309
Double clevis (Including pin, retaining rings, bolts)	151	196	393	554	1109	1887

Calculation: (Example) **CDQ2DS32-20DCMZ**

- Basic weight: CDQ2BS32-20DCZ 250 g
 - Additional weight: Both ends tapped 6 g
 - Rod end male thread 43 g
 - Double clevis 151 g
- 450 g

Add each weight of auto switches when auto switches are mounted.

Construction

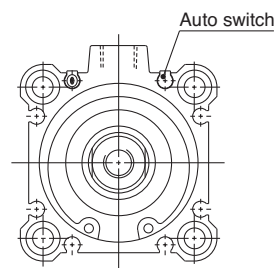
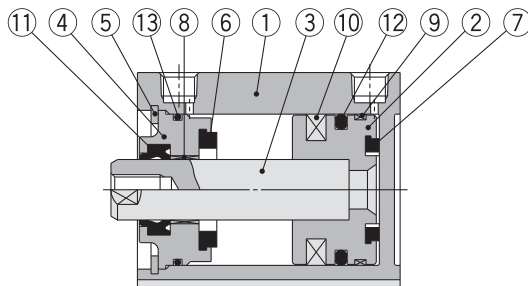

Component Parts

No.	Description	Material	Note
1	Cylinder tube	Aluminum alloy	Hard anodised
2	Piston	Aluminum alloy	Chromated
3	Piston rod	Carbon steel	Hard chrome plated
4	Collar	Aluminum alloy	Anodised
5	Retaining ring	Carbon tool steel	Phosphate coated
6	Bumper A	Urethane	
7	Bumper B	Urethane	
8	Bushing	Bearing alloy	
9	Wear ring	Resin	
10	Magnet	—	
11	Rod seal	NBR	
12	Piston seal	NBR	
13	Tube gasket	NBR	

Replacement Parts/Seal Kit

Bore size (mm)	Kit no.	Contents
32	CQ2B32-PS	Kits include items ①, ②, ⑬ from the table.
40	CQ2B40-PS	
50	CQ2B50-PS	
63	CQ2B63-PS	
80	CQ2B80-PS	
100	CQ2B100-PS	

- * Seal kit includes ①, ②, ⑬ Order the seal kit based on each bore size.
- * Since the seal kit does not include a grease pack, order it separately.

Grease pack part no.: GR-S-010 (10 g)

Series CQ2

Mounting Bolt for CQ2BS/Without Auto Switch

Mounting method: Mounting bolt for through-hole mounting of the CQ2BS is available as an option. Refer to the following for ordering procedures. Order the actual number of bolts that will be used.

Example) CQ-M5 x 40L 4 pcs.

Material: Chromium molybdenum steel
Surface treatment: Zinc chromated

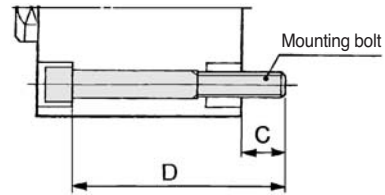

Cylinder model	C	D	Mounting bolt part no.
CQ2BS32-5DCZ	9	40	CQ-M5 x 40L
-10DCZ		45	x 45L
-15DCZ		50	x 50L
-20DCZ		55	x 55L
-25DCZ		60	x 60L
-30DCZ		65	x 65L
-35DCZ		70	x 70L
-40DCZ		75	x 75L
-45DCZ		80	x 80L
-50DCZ		85	x 85L
-75DCZ		120	x 120L
-100DCZ		145	x 145L
CQ2BS40-5DCZ		7.5	45
-10DCZ	50		x 50L
-15DCZ	55		x 55L
-20DCZ	60		x 60L
-25DCZ	65		x 65L
-30DCZ	70		x 70L
-35DCZ	75		x 75L
-40DCZ	80		x 80L
-45DCZ	85		x 85L
-50DCZ	90		x 90L
-75DCZ	125		x 125L
-100DCZ	150		x 150L
CQ2BS50-10DCZ	12.5		55
-15DCZ		60	x 60L
-20DCZ		65	x 65L
-25DCZ		70	x 70L
-30DCZ		75	x 75L
-35DCZ		80	x 80L
-40DCZ		85	x 85L
-45DCZ		90	x 90L
-50DCZ		95	x 95L
-75DCZ		130	x 130L
-100DCZ		155	x 155L

Cylinder model	C	D	Mounting bolt part no.	
CQ2BS63-10DCZ	14.5	60	CQ-M8 x 60L	
-15DCZ		65	x 65L	
-20DCZ		70	x 70L	
-25DCZ		75	x 75L	
-30DCZ		80	x 80L	
-35DCZ		85	x 85L	
-40DCZ		90	x 90L	
-45DCZ		95	x 95L	
-50DCZ		100	x 100L	
-75DCZ		135	x 135L	
-100DCZ		160	x 160L	
CQ2BS80-10DCZ		15	65	CQ-M10 x 65L
-15DCZ			70	x 70L
-20DCZ	75		x 75L	
-25DCZ	80		x 80L	
-30DCZ	85		x 85L	
-35DCZ	90		x 90L	
-40DCZ	95		x 95L	
-45DCZ	100		x 100L	
-50DCZ	105		x 105L	
-75DCZ	140		x 140L	
-100DCZ	165		x 165L	
CQ2BS100-10DCZ	15.5	75	CQ-M10 x 75L	
-15DCZ		80	x 80L	
-20DCZ		85	x 85L	
-25DCZ		90	x 90L	
-30DCZ		95	x 95L	
-35DCZ		100	x 100L	
-40DCZ		105	x 105L	
-45DCZ		110	x 110L	
-50DCZ		115	x 115L	
-75DCZ		150	x 150L	
-100DCZ	175	x 175L		

Mounting Bolt for CDQ2BS/With Auto Switch

Mounting method: Mounting bolt for through-hole mounting of the CDQ2BS is available as an option. Refer to the following for ordering procedures. Order the actual number of bolts that will be used.

Example) CQ-M5 x 50L 4 pcs.

Material: Chromium molybdenum steel
Surface treatment: Zinc chromated

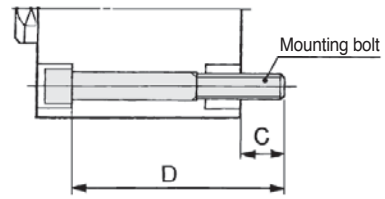

Cylinder model	C	D	Mounting bolt part no.
CDQ2BS32-5DCZ	9	50	CQ-M5 x 50L
-10DCZ		55	x 55L
-15DCZ		60	x 60L
-20DCZ		65	x 65L
-25DCZ		70	x 70L
-30DCZ		75	x 75L
-35DCZ		80	x 80L
-40DCZ		85	x 85L
-45DCZ		90	x 90L
-50DCZ		95	x 95L
-75DCZ		120	x 120L
-100DCZ		145	x 145L
CDQ2BS40-5DCZ	7.5	55	CQ-M5 x 55L
-10DCZ		60	x 60L
-15DCZ		65	x 65L
-20DCZ		70	x 70L
-25DCZ		75	x 75L
-30DCZ		80	x 80L
-35DCZ		85	x 85L
-40DCZ		90	x 90L
-45DCZ		95	x 95L
-50DCZ		100	x 100L
-75DCZ		125	x 125L
-100DCZ		150	x 150L
CDQ2BS50-10DCZ	12.5	65	CQ-M6 x 65L
-15DCZ		70	x 70L
-20DCZ		75	x 75L
-25DCZ		80	x 80L
-30DCZ		85	x 85L
-35DCZ		90	x 90L
-40DCZ		95	x 95L
-45DCZ		100	x 100L
-50DCZ		105	x 105L
-75DCZ		130	x 130L
-100DCZ		155	x 155L

Cylinder model	C	D	Mounting bolt part no.
CDQ2BS63-10DCZ	14.5	70	CQ-M8 x 70L
-15DCZ		75	x 75L
-20DCZ		80	x 80L
-25DCZ		85	x 85L
-30DCZ		90	x 90L
-35DCZ		95	x 95L
-40DCZ		100	x 100L
-45DCZ		105	x 105L
-50DCZ		110	x 110L
-75DCZ		135	x 135L
-100DCZ		160	x 160L
CDQ2BS80-10DCZ		15	75
-15DCZ	80		x 80L
-20DCZ	85		x 85L
-25DCZ	90		x 90L
-30DCZ	95		x 95L
-35DCZ	100		x 100L
-40DCZ	105		x 105L
-45DCZ	110		x 110L
-50DCZ	115		x 115L
-75DCZ	140		x 140L
-100DCZ	165		x 165L
CDQ2BS100-10DCZ	15.5		85
-15DCZ		90	x 90L
-20DCZ		95	x 95L
-25DCZ		100	x 100L
-30DCZ		105	x 105L
-35DCZ		110	x 110L
-40DCZ		115	x 115L
-45DCZ		120	x 120L
-50DCZ		125	x 125L
-75DCZ		150	x 150L
-100DCZ		175	x 175L

- Standard
- Large Bore Size
- Long Stroke
- Non-rotating Rod
- Axial Piping
- Anti-lateral Load
- With End Lock
- Water Resistant
- With Auto Switch
- Auto Switch
- Made to Order

Series CQ2

Dimensions

Ø32 to Ø50/With Auto Switch

(In the case of without auto switches, the A, B dimensions will be only changed. Refer to the dimension table.)

Standard (Through-hole): CQ2BS/CDQ2BS

Both ends tapped: CQ2AS/CDQ2AS

CDQ2AS

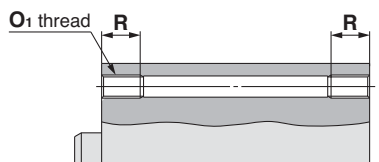

Both Ends Tapped

Bore size (mm)	O ₁	R
32	M6 x 1.0	10
40	M6 x 1.0	10
50	M8 x 1.25	14

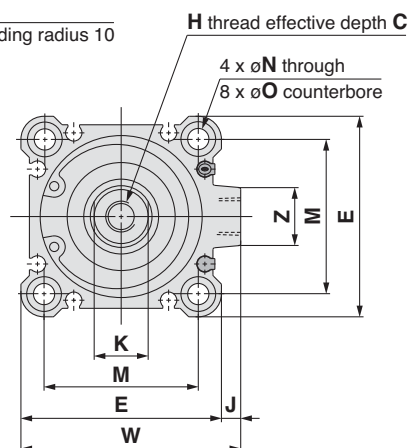
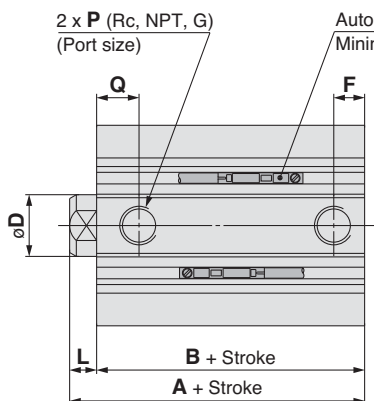

Rod end male thread

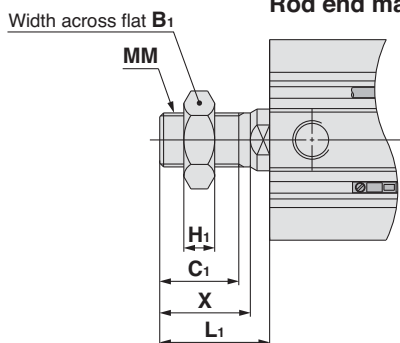

The dimensions with boss on head end are equivalent to those of the CQ2 series, double acting, single rod. Refer to page 17.

Rod End Male Thread

(mm)

Bore size (mm)	B ₁	C ₁	H ₁	L ₁	MM	X
32	22	20.5	8	28.5	M14 x 1.5	23.5
40	22	20.5	8	28.5	M14 x 1.5	23.5
50	27	26	11	33.5	M18 x 1.5	28.5

Bore size (mm)	Stroke range (mm)	Without auto switch		With auto switch		C	D	E	F	H	J	K	L	M	N	O	P	Q	W	Z
		A	B	A	B															
32	5 to 50	40	33	50	43	13	16	45	7.5	M8 x 1.25	4.5	14	7	34	5.5	9 depth 7	1/8	10	49.5	14
	75, 100	50	43																	
40	5 to 50	46.5	39.5	56.5	49.5	13	16	52	7.5	M8 x 1.25	5	14	7	40	5.5	9 depth 7	1/8	12.5	57	15
	75, 100	56.5	49.5																	
50	10 to 50	48.5	40.5	58.5	50.5	15	20	64	10.5	M10 x 1.5	7	17	8	50	6.6	11 depth 8	1/4	10.5	71	19
	75, 100	58.5	50.5																	

Foot: CQ2LS/CDQ2LS

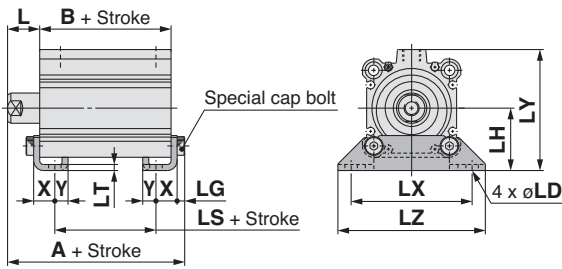

Rod end male thread

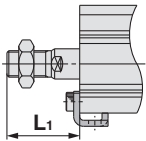

Compact foot: CQ2LCS/CDQ2LCS

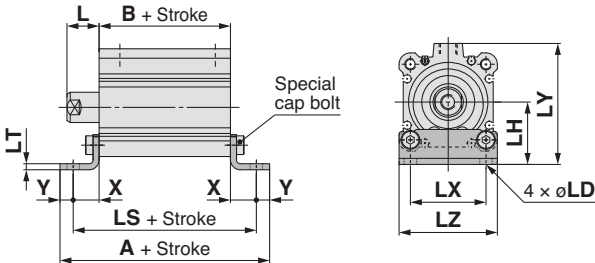

Rod end male thread

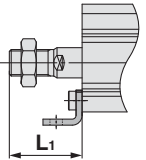

Rod flange: CQ2FS/CDQ2FS

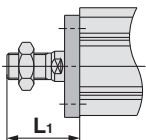
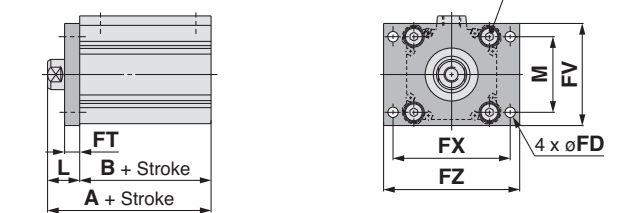

Head flange: CQ2GS/CDQ2GS

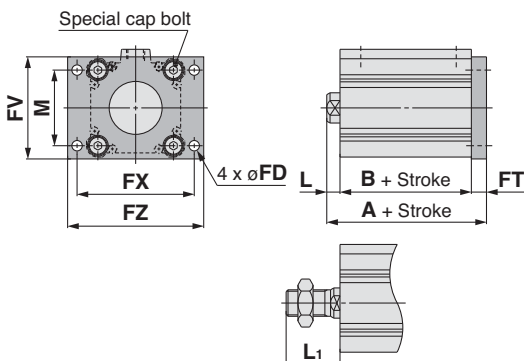

Foot

Bore size (mm)	Stroke range (mm)	Without auto switch			With auto switch			L	L ₁	LD
		A	B	LS	A	B	LS			
32	5 to 50	57.2	33	17	67.2	43	27	17	38.5	6.6
	75, 100	67.2	43	27						
40	5 to 50	63.7	39.5	23.5	73.7	49.5	33.5	17	38.5	6.6
	75, 100	73.7	49.5	33.5						
50	10 to 50	66.7	40.5	17.5	76.7	50.5	27.5	18	43.5	9
	75, 100	76.7	50.5	27.5						

Foot bracket material: Carbon steel
Surface treatment: Nickel plated

Compact Foot

Bore size (mm)	Stroke range (mm)	Without auto switch			With auto switch			L	L ₁	LD
		A	B	LS	A	B	LS			
32	5 to 50	72	33	60.4	82	43	70.4	17	38.5	6.6
	75, 100	82	43	70.4						
40	5 to 50	80.9	39.5	66.9	90.9	49.5	76.9	17	38.5	6.6
	75, 100	90.9	49.5	76.9						
50	10 to 50	89.9	40.5	73.9	99.9	50.5	83.9	18	43.5	9
	75, 100	99.9	50.5	83.9						

Compact foot bracket material: Carbon steel
Surface treatment: Zinc chromated

Rod Flange

Bore size (mm)	Stroke range (mm)	Without auto switch		With auto switch		FD	FT	FV	FX	FZ
		A	B	A	B					
32	5 to 50	50	33	60	43	5.5	8	48	56	65
	75, 100	60	43							
40	5 to 50	56.5	39.5	66.5	49.5	5.5	8	54	62	72
	75, 100	66.5	49.5							
50	10 to 50	58.5	40.5	68.5	50.5	6.6	9	67	76	89
	75, 100	68.5	50.5							

Bore size (mm)	Stroke range (mm)	L	L ₁	M
32	5 to 50	17	38.5	34
	75, 100			
40	5 to 50	17	38.5	40
	75, 100			
50	10 to 50	18	43.5	50
	75, 100			

Flange bracket material: Carbon steel
Surface treatment: Nickel plated

Head Flange

Bore size (mm)	Stroke range (mm)	Without auto switch		With auto switch	
		A	A	L	L ₁
32	5 to 50	48	58	7	28.5
	75, 100	58			
40	5 to 50	54.5	64.5	7	28.5
	75, 100	64.5			
50	10 to 50	57.5	67.5	8	33.5
	75, 100	67.5			

(* The dimensions except A, L and L₁ are the same as those of the rod flange.)
Flange bracket material: Carbon steel
Surface treatment: Nickel plated

Standard

Large Bore Size

Long Stroke

Non-rotating Rod

Axial Piping

Anti-lateral Load

With End Lock

Water Resistant

With Auto Switch

Auto Switch

Made to Order

Series CQ2

Double clevis: CQ2DS/CDQ2DS

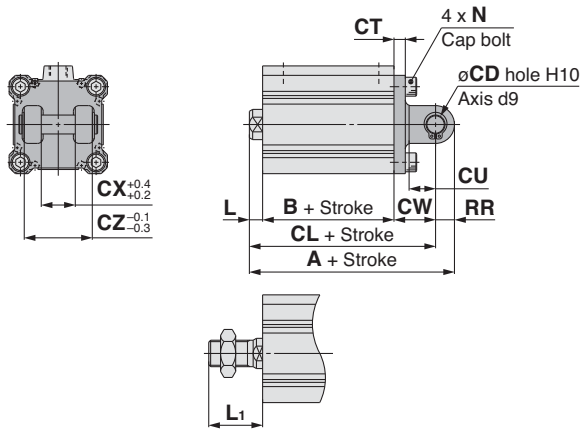

Double Clevis

Bore size (mm)	Stroke range (mm)	Without auto switch			With auto switch			CD	CT	CU
		A	B	CL	A	B	CL			
32	5 to 50	70	33	60	80	43	70	10	5	14
	75, 100	80	43	70						
40	5 to 50	78.5	39.5	68.5	88.5	49.5	78.5	10	6	14
	75, 100	88.5	49.5	78.5						
50	10 to 50	90.5	40.5	76.5	100.5	50.5	86.5	14	7	20
	75, 100	100.5	50.5	86.5						

Bore size (mm)	Stroke range (mm)	CW	CX	CZ	L	L ₁	N	RR
32	5 to 50	20	18	36	7	28.5	M6 x 1.0	10
	75, 100							
40	5 to 50	22	18	36	7	28.5	M6 x 1.0	10
	75, 100							
50	10 to 50	28	22	44	8	33.5	M8 x 1.25	14
	75, 100							

Double clevis bracket material: Cast iron
Surface treatment: Painted

* For details about the rod end nut and accessory brackets, refer to page 23.

* Double clevis pin and retaining rings are included.

Series CQ2

Dimensions

∅63 to ∅100/With Auto Switch

(In the case of without auto switches, the A, B dimensions will be only changed. Refer to the dimension table.)

Standard (Through-hole): CQ2BS/CDQ2BS

Both ends tapped: CQ2AS/CDQ2AS

The dimensions with boss on head side are equivalent to those of the CQ2 series, double acting, single rod. Refer to page 19.

Both Ends Tapped

Bore size (mm)	O ₁	R
63	M10 x 1.5	18
80	M12 x 1.75	22
100	M12 x 1.75	22

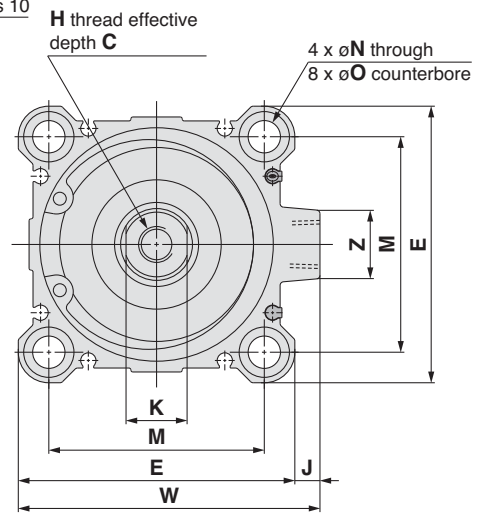
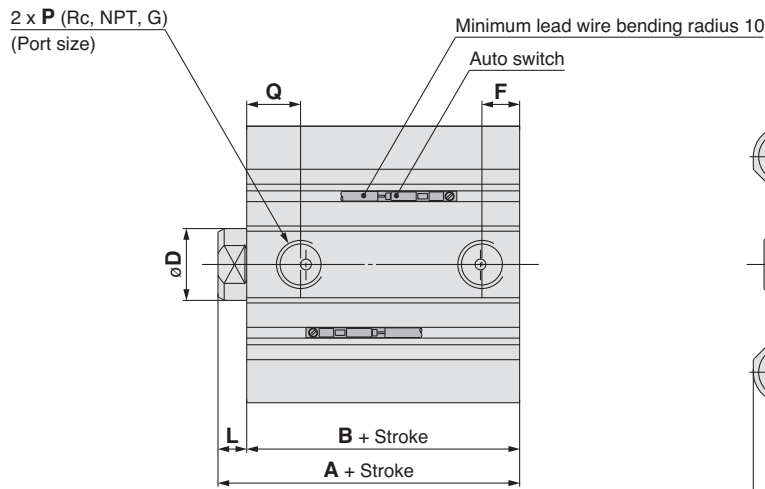
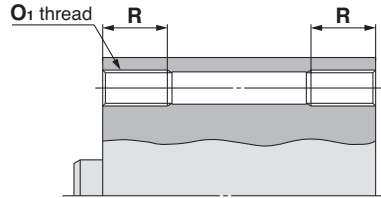

Rod end male thread

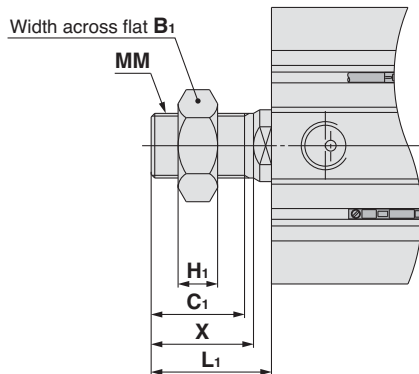

Rod End Male Thread

(mm)

Bore size (mm)	B ₁	C ₁	H ₁	L ₁	MM	X
63	27	26	11	33.5	M18 x 1.5	28.5
80	32	32.5	13	43.5	M22 x 1.5	35.5
100	41	32.5	16	43.5	M26 x 1.5	35.5

Bore size (mm)	Stroke range (mm)	Without auto switch		With auto switch		C	D	E	F	H	J	K	L	M	N	O	P	Q	W	Z
		A	B	A	B															
63	10 to 50	54	46	64	56	15	20	77	10.5	M10 x 1.5	7	17	8	60	9	14 depth 10.5	1/4	15	84	19
	75, 100	64	56																	
80	10 to 50	63.5	53.5	73.5	63.5	21	25	98	12.5	M16 x 2.0	6	22	10	77	11	17.5 depth 13.5	3/8	16	104	25
	75, 100	73.5	63.5																	
100	10 to 50	75	63	85	73	27	30	117	13	M20 x 2.5	6.5	27	12	94	11	17.5 depth 13.5	3/8	23	123.5	25
	75, 100	85	73																	

Series CQ2

Foot: CQ2LS/CDQ2LS

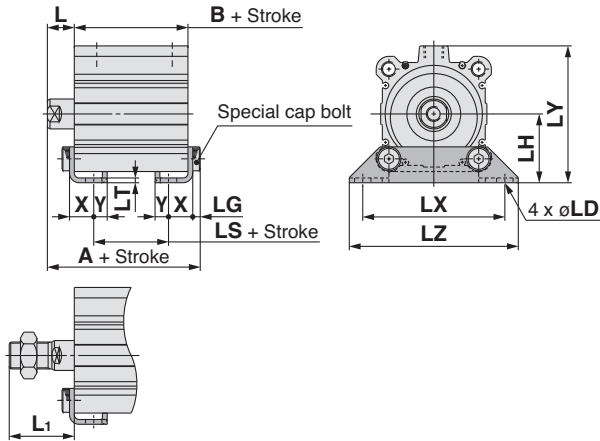

Compact foot: CQ2LCS/CDQ2LCS

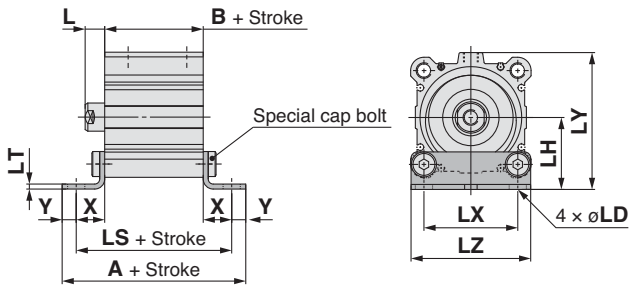

Rod end male thread

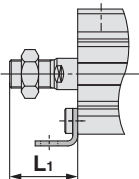

Rod flange: CQ2FS/CDQ2FS

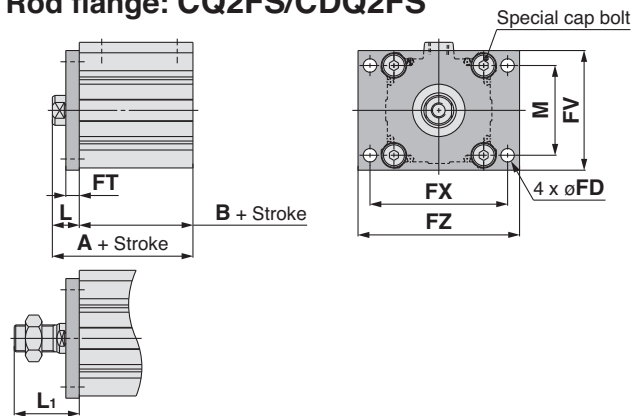

Head flange: CQ2GS/CDQ2GS

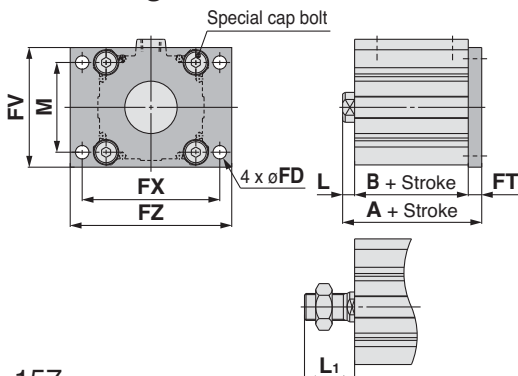

Foot

Bore size (mm)	Stroke range (mm)	Without auto switch			With auto switch			L	L ₁	LD
		A	B	LS	A	B	LS			
63	10 to 50	72.2	46	20	82.2	56	30	18	43.5	11
	75, 100	82.2	56	30						
80	10 to 50	85	53.5	23.5	95	63.5	33.5	20	53.5	13
	75, 100	95	63.5	33.5						
100	10 to 50	98	63	29	108	73	39	22	53.5	13
	75, 100	108	73	39						

Bore size (mm)	Stroke range (mm)	LG	LH	LT	LX	LY	LZ	X	Y
63	10 to 50	5	46	3.2	95	91.5	113	16.2	9
	75, 100								
80	10 to 50	7	59	4.5	118	114	140	19.5	11
	75, 100								
100	10 to 50	7	71	6	137	136	162	23	12.5
	75, 100								

Foot bracket material: Carbon steel
Surface treatment: Nickel plated

Compact Foot

Bore size (mm)	Stroke range (mm)	Without auto switch			With auto switch			L	L ₁	LD
		A	B	LS	A	B	LS			
63	10 to 50	100.4	46	82.4	110.4	56	92.4	18	43.5	11
	75, 100	110.4	56	92.4						
80	10 to 50	120.5	53.5	98.5	130.5	63.5	108.5	20	53.5	13
	75, 100	130.5	63.5	108.5						
100	10 to 50	136	63	111	146	73	121	22	53.5	13
	75, 100	146	73	121						

Bore size (mm)	Stroke range (mm)	LH	LT	LX	LY	LZ	X	Y
63	10 to 50	46	3.2	60	91.5	77	18.2	9
	75, 100							
80	10 to 50	59	4.5	77	114	98	22.5	11
	75, 100							
100	10 to 50	71	6	94	136	117	24	12.5
	75, 100							

Compact foot bracket material: Carbon steel
Surface treatment: Zinc chromated

Rod Flange

Bore size (mm)	Stroke range (mm)	Without auto switch		With auto switch		FD	FT	FV	FX	FZ
		A	B	A	B					
63	10 to 50	64	46	74	56	9	9	80	92	108
	75, 100	74	56							
80	10 to 50	73.5	53.5	83.5	63.5	11	11	99	116	134
	75, 100	83.5	63.5							
100	10 to 50	85	63	95	73	11	11	117	136	154
	75, 100	95	73							

Bore size (mm)	Stroke range (mm)	L	L ₁	M
63	10 to 50	18	43.5	60
	75, 100			
80	10 to 50	20	53.5	77
	75, 100			
100	10 to 50	22	53.5	94
	75, 100			

Flange bracket material: Carbon steel
Surface treatment: Nickel plated

Head Flange

Bore size (mm)	Stroke range (mm)	Without auto switch		With auto switch	
		A	A	L	L ₁
63	10 to 50	63	73	8	33.5
	75, 100	73			
80	10 to 50	74.5	84.5	10	43.5
	75, 100	84.5			
100	10 to 50	86	96	12	43.5
	75, 100	96			

(* The dimensions except A, L and L₁ are the same as those of the rod flange.)
Flange bracket material: Carbon steel
Surface treatment: Nickel plated

Double clevis: CQ2DS/CDQ2DS

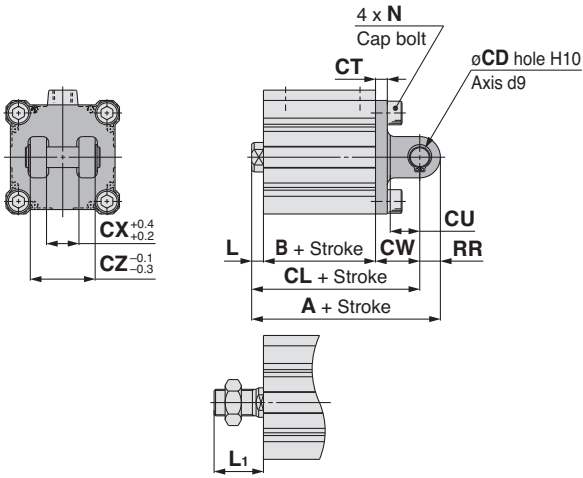

Double Clevis

Bore size (mm)	Stroke range (mm)	Without auto switch			With auto switch			CD	CT	CU
		A	B	CL	A	B	CL			
63	10 to 50	98	46	84	108	56	94	14	8	20
	75, 100	108	56	94						
80	10 to 50	119.5	53.5	101.5	129.5	63.5	111.5	18	10	27
	75, 100	129.5	63.5	111.5						
100	10 to 50	142	63	120	152	73	130	22	13	31
	75, 100	152	73	130						

Bore size (mm)	Stroke range (mm)	CW	CX	CZ	L	L ₁	N	RR
63	10 to 50	30	22	44	8	33.5	M10 x 1.5	14
	75, 100							
80	10 to 50	38	28	56	10	43.5	M12 x 1.75	18
	75, 100							
100	10 to 50	45	32	64	12	43.5	M12 x 1.75	22
	75, 100							

Double clevis bracket material: Cast iron
Surface treatment: Painted

- * For details about the rod end nut and accessory brackets, refer to page 23.
- * Double clevis pin and retaining rings are included.

Standard

Large Bore Size

Long Stroke

Non-rotating Rod

Axial Piping

Anti-lateral Load

With End Lock

Water Resistant

With Auto Switch

Auto Switch

Made to Order

Compact Cylinder: With End Lock

Series CBQ2

ø20, ø25, ø32, ø40, ø50, ø63, ø80, ø100

How to Order

Without auto switch

CBQ2 B 40 - 30 DC - H N

With auto switch

CDBQ2 B 40 - 30 DC - H N - M9BW

With auto switch
(Built-in magnet)

ø20, ø25

ø32 to ø100

ø20, ø25		ø32 to ø100	
B	Through-hole/Both ends tapped common (Standard)	B	Through-hole (Standard) <small>Note 2)</small>
L	Foot	A	Both ends tapped
LC	Compact foot	L	Foot
F	Rod flange	LC	Compact foot
G	Head flange	F	Rod flange
D	Double clevis	G	Head flange
		D	Double clevis

Note 1) Mounting brackets are shipped together, (but not assembled).

Note 2) At the 75 and 100 mm strokes with ø80, ø100, both ends tapped (A) is the standard. Through-hole (B) is not available.

Note 3) Mounting brackets are shipped together, (but not assembled).

Bore size

20	20 mm	50	50 mm
25	25 mm	63	63 mm
32	32 mm	80	80 mm
40	40 mm	100	100 mm

Port thread type

	M thread	ø20, ø25
	Rc	
TN	NPT	ø32 to ø100
TF	G	

Cylinder stroke (mm)

Refer to the next page for standard strokes and intermediate strokes.

Number of auto switches

-	2 pcs.
S	1 pc.
n	"n" pcs.

Auto switch

- Without auto switch

* Refer to the below table for applicable auto switches.

Manual release type

N	Non-lock type
L	Lock type

Lock position

H	Head end lock
R	Rod end lock

Body option

-	Rod end female thread
CM	Rod end male thread

Made to Order

Refer to the next page for details.

Cushion

C Rubber bumper

Built-in Magnet Cylinder Model

If a built-in magnet cylinder without an auto switch is required, there is no need to enter the symbol for the auto switch.

(Example) CDBQ2L32-30DC-RL

Action

D Double acting

Applicable Auto Switches/Refer to pages 1263 to 1371 in Best Pneumatics No. 2 for further information on auto switches.

Type	Special function	Electrical entry	Indicator light	Wiring (Output)	Load voltage		Auto switch model		Lead wire length (m)					Pre-wired connector	Applicable load							
					DC	AC	Perpendicular		In-line		0.5 (-)	1 (M)	3 (L)			5 (Z)	None (N)					
							ø20, ø25	ø32 to ø100	ø20, ø25	ø32 to ø100												
Solid state auto switch	—	Grommet	No	3-wire (NPN)	24 V	—	5 V, 12 V	M9NV	M9N	●	●	●	○	—	○	IC circuit						
				3-wire (PNP)				M9PV	M9P	●	●	●	○	—	○							
		2-wire	M9BV	M9B				●	●	●	○	—	○	—								
		—	J79C	—				●	—	●	●	●	—		—							
	Diagnostic indication (2-colour indication)	Grommet	Yes	3-wire (NPN)	24 V	—	5 V, 12 V	M9NWV	M9NW	●	●	●	○	—	○	IC circuit						
				3-wire (PNP)				M9PWV	M9PW	●	●	●	○	—	○							
				2-wire				M9BWV	M9BW	●	●	●	○	—	○		—					
				3-wire (NPN)				M9NAV**	M9NA**	○	○	●	○	—	○							
				3-wire (PNP)				M9PAV**	M9PA**	○	○	●	○	—	○		IC circuit					
				2-wire				M9BAV**	M9BA**	○	○	●	○	—	○							
With diagnostic output (2-colour indication)	Grommet	No	4-wire	24 V	—	5 V, 12 V	—	F79F	●	—	●	○	—	○	IC circuit							
Magnetic field resistant (2-colour indication)			2-wire (Non-polar)				—	P4DW	—	—	●	●	—	○								
Reed auto switch	—	Grommet	Yes	3-wire (NPN equivalent)	24 V	—	5 V, 12 V	A96V	A96	●	—	●	—	—	—	IC circuit						
				—				A72	—	A72H	●	—	●	—	—		—					
				12 V				A93V	—	A93	●	—	●	—	—							
		Connector	No	Yes				2-wire	24 V	—	5 V, 12 V	100 V or less	A90V	A90	●	—	●	—	—	IC circuit		
												24 V or less	A73C	—	—	●	—	●	●		—	
												—	A80C	—	—	●	—	●	●		—	IC circuit
												24 V or less	A79W	—	—	●	—	●	—		—	
Diagnostic indication (2-colour indication)	Grommet	Yes	—	24 V	—	5 V, 12 V	—	—	—	—	—	—	—	—	—							
							—	—	—	—	—	—	—	—		—						

* Water resistant type auto switches can be mounted on the above models, but in such case SMC cannot guarantee water resistance.

Consult with SMC regarding water resistant types with the above model numbers.

* Lead wire length symbols: 0.5 m — (Example) M9NW
1 m M (Example) M9NWM
3 m L (Example) M9NWL
5 m Z (Example) M9NWZ
None N (Example) J79CN

* Solid state auto switches marked with "○" are produced upon receipt of order.

* The D-P4DWL type is available from ø40 to ø100 only.

* Only for the D-P4DWL type, an auto switch is assembled and shipped with the cylinder.

* There are other applicable auto switches other than the listed above. For details, refer to page 177.

* For details about auto switches with pre-wired connector, refer to pages 1328 and 1329 in Best Pneumatics No. 2.

* When the D-A9□(V)/M9□(V)/M9□W(V)/M9□A(V)L types with ø32 to ø50 are mounted on a surface other than the port side, order auto switch mounting brackets separately. Refer to page 176 for details.

Series CBQ2



Specifications

Bore size (mm)	20	25	32	40	50	63	80	100
Action	Double acting, Single rod							
Fluid	Air							
Proof pressure	1.5 MPa							
Maximum operating pressure	1.0 MPa							
Minimum operating pressure	0.15 MPa <small>Note)</small>							
Ambient and fluid temperature	Without auto switch: -10 to 70°C (No freezing) With auto switch: -10 to 60°C (No freezing)							
Lubrication	Not required (Non-lube)							
Piston speed	50 to 500 mm/s							
Allowable kinetic energy (J)	0.055	0.09	0.15	0.26	0.46	0.77	1.36	2.27
Stroke length tolerance	+1.0 mm 0							
Lock position	Head end, Rod end							
Holding force (Max.) (N)	215	330	550	860	1340	2140	3450	5390
Pressure for unlocking	0.15 MPa or less							
Backlash	2 mm or less							
Manual release	Non-lock type, Lock type							

Note) 0.05 MPa except for the end lock unit



Made to Order
(For details, refer to pages 201 to 235.)

Symbol	Specifications
-XB10	Intermediate stroke (Using exclusive body)
-XC26	With split pins for double clevis pin/ double knuckle joint pin and flat washers
-XC85	Grease for food processing equipment

Refer to pages 173 to 177 for the specifications of cylinders with autoswitches.

- Auto switch proper mounting position (detection at stroke end) and its mounting height
- Minimum stroke for auto switch mounting
- Operating range
- Auto switch mounting brackets/Part no.

Standard Strokes

Bore size	Standard stroke (mm)
20 to 63	10, 15, 20, 25, 50, 75, 100
80, 100	25, 50, 75, 100

Manufacture of Intermediate Strokes

Type	A spacer is installed in the standard stroke body.	Exclusive body (-XB10)								
Part no.	Refer to "How to Order" for the standard model number. (P. 160)	Suffix "-XB10" to the end of standard model no. on page 160.								
Description	Strokes in 5 mm intervals are available by installing a spacer in the standard stroke cylinder.	Dealing with the stroke by the 1 mm interval by using an exclusive body with the specified stroke.								
Stroke range	<table border="1"> <thead> <tr> <th>Bore size</th> <th>Stroke range</th> </tr> </thead> <tbody> <tr> <td>20 to 100</td> <td>5 to 95</td> </tr> </tbody> </table>	Bore size	Stroke range	20 to 100	5 to 95	<table border="1"> <thead> <tr> <th>Bore size</th> <th>Stroke range</th> </tr> </thead> <tbody> <tr> <td>20 to 100</td> <td>6 to 99</td> </tr> </tbody> </table>	Bore size	Stroke range	20 to 100	6 to 99
Bore size	Stroke range									
20 to 100	5 to 95									
Bore size	Stroke range									
20 to 100	6 to 99									
Example	Part no.: CBQ2B40-45DC-HL CBQ2B40-50DC-HL with 5 mm width spacer inside. B dimension is 125 mm.	Part no.: CBQ2B40-45DC-HL-XB10 Makes 45 stroke tube. B dimension is 120 mm.								

In the case of an exclusive body type for $\phi 20$, $\phi 25$, $\phi 80$ and $\phi 100$ (-XB10) with the stroke length exceeding 25 mm, the reference values of the longitudinal dimension will be changed. Subtract from 50, 75 and 100 stroke dimensions and figure it out.

Mounting Brackets/Part No.

Bore size (mm)	Foot <small>Note 1)</small>	Compact Foot <small>Note 1)</small>	Flange	Double clevis <small>Note 2)</small>
20	CQS-L020	CQS-LC020	CQS-F020	CQS-D020
25	CQS-L025	CQS-LC025	CQS-F025	CQS-D025
32	CQ-L032	CQ-LC032	CQ-F032	CQ-D032
40	CQ-L040	CQ-LC040	CQ-F040	CQ-D040
50	CQ-L050	CQ-LC050	CQ-F050	CQ-D050
63	CQ-L063	CQ-LC063	CQ-F063	CQ-D063
80	CQ-L080	CQ-LC080	CQ-F080	CQ-D080
100	CQ-L100	CQ-LC100	CQ-F100	CQ-D100

Note 1) When ordering a foot, compact foot brackets, order 2 pieces per cylinder.

Note 2) Parts belonging to each bracket are as follows.

Foot, Compact foot, Flange: Body mounting bolts

Double clevis: Clevis pin, Type C retaining rings for axis, Body mounting bolts

Note 3) Clevis pin and retaining rings are included with double clevis.

Allowable Kinetic Energy

With Rubber Bumper

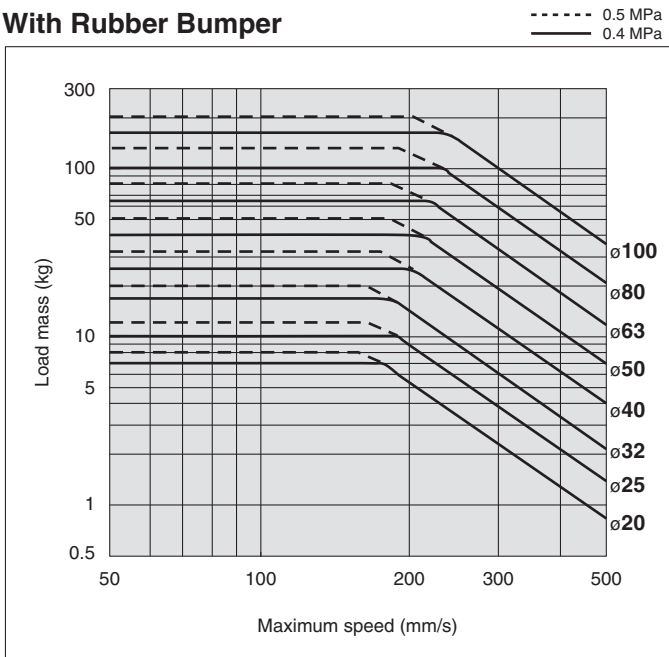

Allowable Lateral Load at Rod End

With Auto Switch

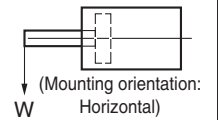
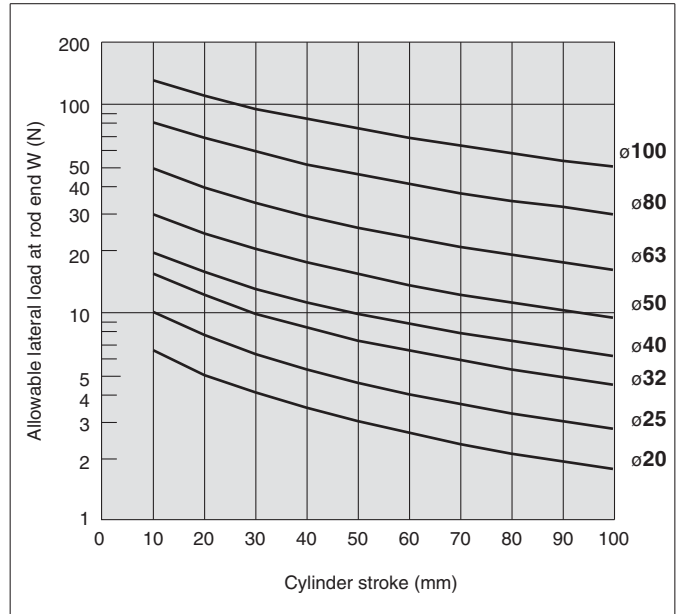

- Standard
- Large Bore Size
- Long Stroke
- Non-rotating Rod
- Axial Piping
- Anti-lateral Load
- With End Lock
- Water Resistant
- With Auto Switch
- Auto Switch
- Made to Order

Series CBQ2

Mounting Bolt for CBQ2

Mounting method: Mounting bolt for through-hole mounting of the C(D)BQ2 is available as an option. Refer to the following for ordering procedures. Order the actual number of bolts that will be used.

Example) CQ-M5 x 75L 4 pcs.

Note) Be sure to use the attached flat washers when mounting $\phi 20$ and $\phi 25$ cylinders with through-holes.

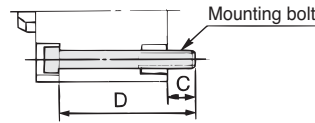

Material: Chromium molybdenum steel
Surface treatment: Zinc chromated

With Head End Lock (H□)

Cylinder model	C	D	Mounting bolt part no.
C□BQ2B20-10DC-H□	10	75	CQ-M5 x 75L
-15DC-H□		80	x 80L
-20DC-H□		85	x 85L
-25DC-H□		90	x 90L
-50DC-H□		120	x 120L
-75DC-H□		145	x 145L
-100DC-H□		170	x 170L
C□BQ2B25-10DC-H□	7	75	CQ-M5 x 75L
-15DC-H□		80	x 80L
-20DC-H□		85	x 85L
-25DC-H□		90	x 90L
-50DC-H□		120	x 120L
-75DC-H□		145	x 145L
-100DC-H□		170	x 170L
C□BQ2B32-10DC-H□	6.5	75	CQ-M5 x 75L
-15DC-H□		80	x 80L
-20DC-H□		85	x 85L
-25DC-H□		90	x 90L
-50DC-H□		115	x 115L
-75DC-H□		140	x 140L
-100DC-H□		165	x 165L
C□BQ2B40-10DC-H□	7	85	CQ-M5 x 85L
-15DC-H□		90	x 90L
-20DC-H□		95	x 95L
-25DC-H□		100	x 100L
-50DC-H□		125	x 125L
-75DC-H□		150	x 150L
-100DC-H□		175	x 175L

Cylinder model	C	D	Mounting bolt part no.
C□BQ2B50-10DC-H□	12.5	90	CQ-M6 x 90L
-15DC-H□		95	x 95L
-20DC-H□		100	x 100L
-25DC-H□		105	x 105L
-50DC-H□		130	x 130L
-75DC-H□		155	x 155L
-100DC-H□		180	x 180L
C□BQ2B63-10DC-H□	13.5	90	CQ-M8 x 90L
-15DC-H□		95	x 95L
-20DC-H□		100	x 100L
-25DC-H□		105	x 105L
-50DC-H□		130	x 130L
-75DC-H□		155	x 155L
-100DC-H□		180	x 180L
C□BQ2B80-25DC-H□	12.5	135	CQ-M10 x 135L
-50DC-H□		160	x 160L
C□BQ2B100-25DC-H□	13	145	CQ-M10 x 145L
-50DC-H□		170	x 170L

With Rod End Lock (R□)

Cylinder model	C	D	Mounting bolt part no.
C□BQ2B20-10DC-R□	6.5	65	CQ-M5 x 65L
-15DC-R□		70	x 70L
-20DC-R□		75	x 75L
-25DC-R□		80	x 80L
-50DC-R□		120	x 120L
-75DC-R□	10	145	x 145L
-100DC-R□		170	x 170L
C□BQ2B25-10DC-R□		8.5	70
-15DC-R□	75		x 75L
-20DC-R□	80		x 80L
-25DC-R□	85		x 85L
-50DC-R□	120		x 120L
-75DC-R□	7	145	x 145L
-100DC-R□		170	x 170L
C□BQ2B32-10DC-R□		9	70
-15DC-R□	75		x 75L
-20DC-R□	80		x 80L
-25DC-R□	85		x 85L
-50DC-R□	110		x 110L
-75DC-R□	135		x 135L
-100DC-R□	160		x 160L
C□BQ2B40-10DC-R□	7.5	75	CQ-M5 x 75L
-15DC-R□		80	x 80L
-20DC-R□		85	x 85L
-25DC-R□		90	x 90L
-50DC-R□		115	x 115L
-75DC-R□		140	x 140L
-100DC-R□		165	x 165L

Cylinder model	C	D	Mounting bolt part no.
C□BQ2B50-10DC-R□	12.5	80	CQ-M6 x 80L
-15DC-R□		85	x 85L
-20DC-R□		90	x 90L
-25DC-R□		95	x 95L
-50DC-R□		120	x 120L
-75DC-R□		145	x 145L
-100DC-R□		170	x 170L
C□BQ2B63-10DC-R□	14.5	85	CQ-M8 x 85L
-15DC-R□		90	x 90L
-20DC-R□		95	x 95L
-25DC-R□		100	x 100L
-50DC-R□		125	x 125L
-75DC-R□		150	x 150L
-100DC-R□		175	x 175L
C□BQ2B80-25DC-R□	15	130	CQ-M10 x 130L
-50DC-R□		155	x 155L
C□BQ2B100-25DC-R□	15.5	140	CQ-M10 x 140L
-50DC-R□		165	x 165L

Construction

ø32 to ø63

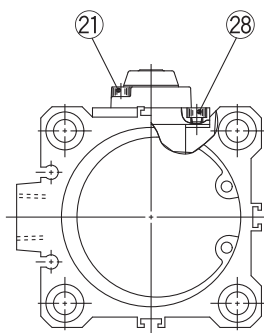

Cylinder tube form
ø32 to ø63

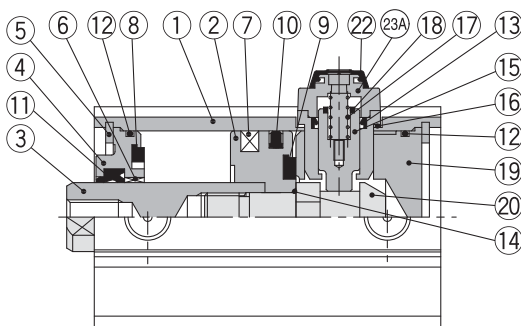

Head end lock

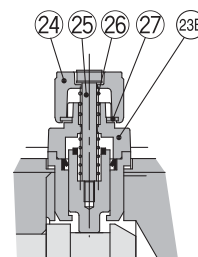

Manual release (Lock type): Suffix L

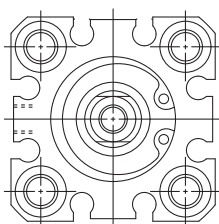

Cylinder tube form
ø25 or less

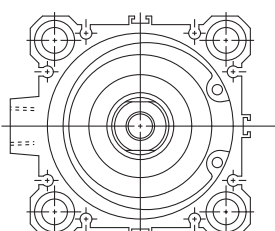

Cylinder tube form
ø80 or more

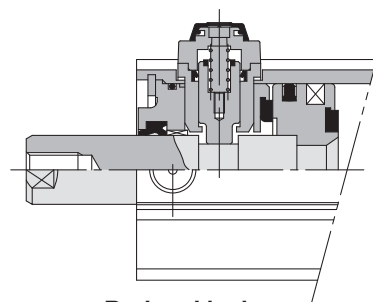

Rod end lock

ø20, 25

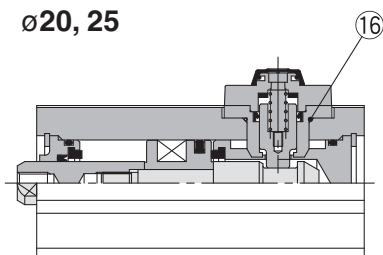

ø80, 100

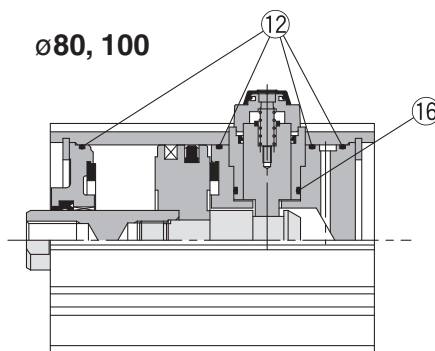

Component Parts

No.	Description	Material	Note
1	Cylinder tube	Aluminum alloy	Hard anodised
2	Piston	Aluminum alloy	Chromated
3	Piston rod	Carbon steel	Hard chrome plated
4	Collar	R□ Aluminum alloy	Anodised
		H□ Aluminum alloy	ø40 or less, Anodised
		Aluminum alloy casted	ø50 or more, Painted after chromated
5	Retaining ring	Carbon tool steel	Phosphate coated
6	Bushing	R□ Copper alloy	Used for all bore sizes
		H□	Used for ø40 or more
7	Magnet	—	With auto switch
8	Bumper A	Urethane	
9	Bumper B	Urethane	
10	Piston seal	NBR	
11	Rod seal	NBR	
12	Tube gasket	NBR	Using 4 pcs. for ø80, ø100
13	Lock piston seal	NBR	
14	Piston gasket	NBR	Nothing for ø20, ø25
15	Lock piston	Carbon steel	Quenched, Hard chrome plated
16	Gasket	NBR	
17	Lock spring	Stainless steel	
18	Bumper	Urethane	
19	Head cover	Aluminum alloy	Anodised
20	Lock bolt	Carbon steel	Quenched, Electroless nickel plated
21	Hexagon socket head cap screw	Alloy steel	Black zinc chromated
22	Rubber cap	Synthetic rubber	
23A	Cap A	Aluminum casted	Black painted
23B	Cap B	Carbon steel	Oxide film treated

No.	Description	Material	Note
24	M/O knob	Zinc die-casted	Black painted
25	M/O bolt	Alloy steel	Black zinc chromated, Red painted
26	M/O spring	Steel wire	Zinc chromated
27	Stopper ring	Rolled steel	Zinc chromated
28	Hexagon socket head cap screw	Alloy steel	Nickel plated

Replacement Parts/Seal Kit (End lock type)

Bore size (mm)	Kit no.	Contents
20	CBQ2B20-PS	Kits include items 10, 11, 12, 13, 16, 21, 28 from the table and a grease pack.
25	CBQ2B25-PS	
32	CBQ2B32-PS	
40	CBQ2B40-PS	
50	CBQ2B50-PS	
63	CBQ2B63-PS	
80	CBQ2B80-PS	
100	CBQ2B100-PS	

* Seal kit includes 10, 11, 12, 13, 16, 21, 28. Order the seal kit based on each bore size.

* Since the seal kit does not include a grease pack, order it separately.

Grease pack part no.: GR-S-010 (10 g)

Standard
Large Bore Size
Long Stroke
Non-rotating Rod
Axial Piping
Anti-lateral Load
With End Lock
Water Resistant
With Auto Switch
Auto Switch
Made to Order

Series CBQ2

Dimensions

Ø20, Ø25

Standard (Through-hole/Both ends tapped common):
CBQ2B/CDBQ2B

End lock mechanism (Manual release lock type)

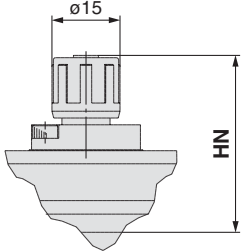

End Lock Mechanism Dimensions (mm)

Bore size (mm)	DL	DM	HR	HN (Max.)
20	20	21	28.5	40
25	21	21	29.5	41

With head end lock

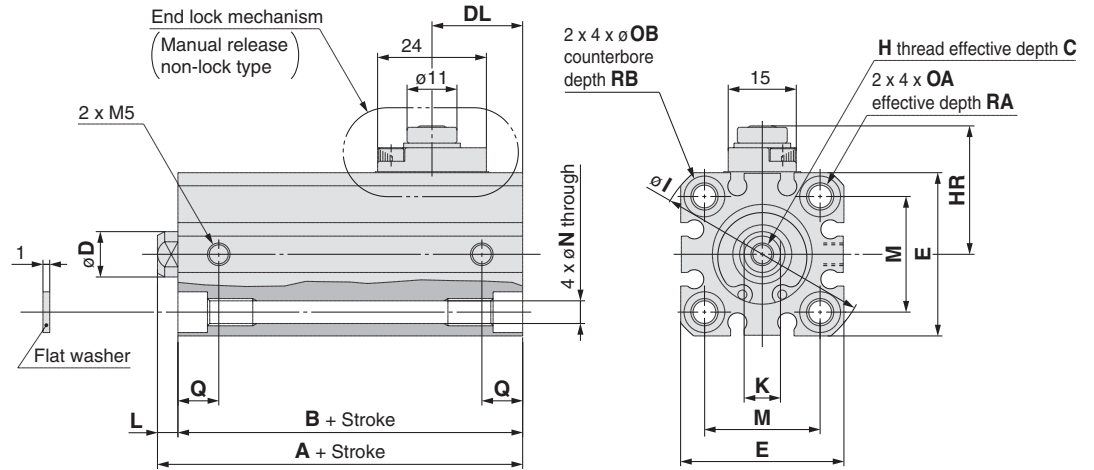

With rod end lock

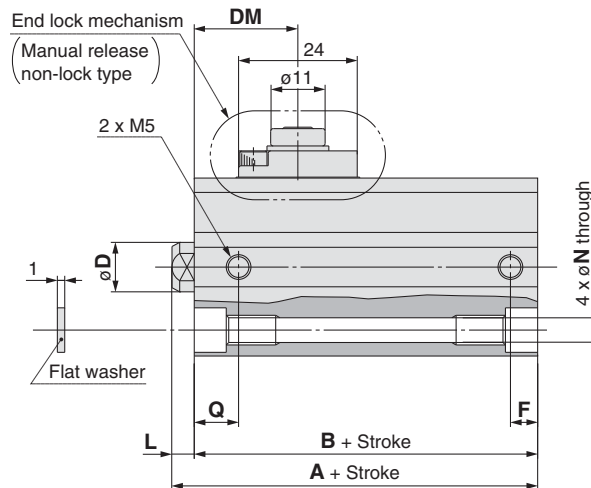

Rod end male thread

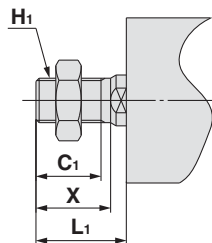

Rod End Male Thread

Bore size (mm)	Standard stroke	C ₁	X	H ₁	L ₁
20	10, 15, 20, 25	12	14	M8 x 1.25	18.5
	50, 75, 100				28.5
25	10, 15, 20, 25	15	17.5	M10 x 1.25	22.5
	50, 75, 100				32.5

Bore size (mm)	Standard stroke	With head end lock				With rod end lock				C	D	E	H	I	K	M	N	OA	OB	Q	RA	RB
		A	B	L	A	B	F	L														
20	10, 15, 20, 25	65.5	61	4.5	59	54.5	5.5	4.5	7	10	36	M5 x 0.8	47	8	25.5	5.4	M6 x 1.0	9	9	10	7	
	50, 75, 100	80.5	66	14.5	80.5	66	9	14.5														
25	10, 15, 20, 25	69	64	5	62.5	57.5	5.5	5	12	12	40	M6 x 1.0	52	10	28	5.4	M6 x 1.0	9	11	10	7	
	50, 75, 100	84	69	15	84	69	11	15														

Foot: CBQ2L/CDBQ2L

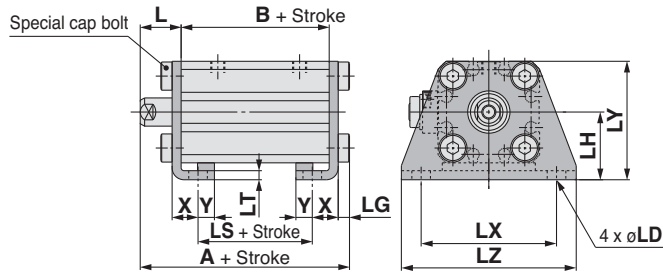

Rod end male thread

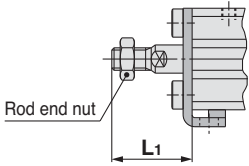

Compact foot: CBQ2LC/CDBQ2LC

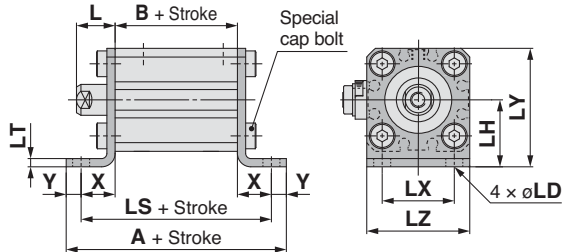

Rod end male thread

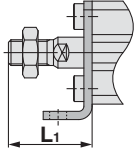

Rod flange: CBQ2F/CDBQ2F

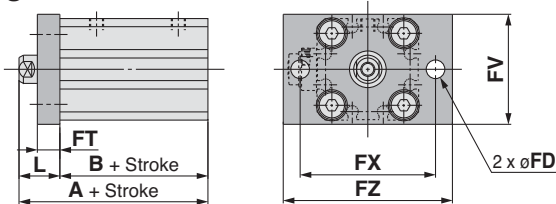

Rod end male thread

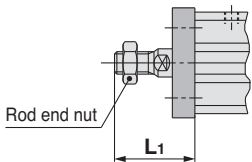

Head flange: CBQ2G/CDBQ2G

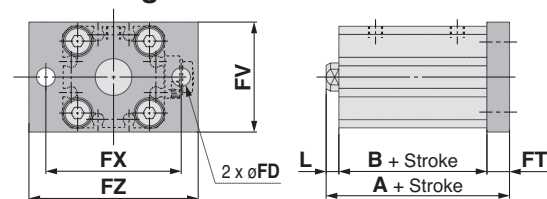

Rod end male thread

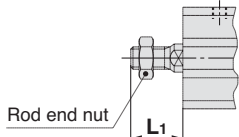

Foot

Bore size (mm)	Standard stroke	With head end lock			With rod end lock		
		A	B	LS	A	B	LS
20	10, 15, 20, 25	82.7	61	49	76.2	54.5	42.5
	50, 75, 100	87.7	66	54	87.7	66	54
25	10, 15, 20, 25	86.2	64	49	79.7	57.5	42.5
	50, 75, 100	91.2	69	54	91.2	69	54

Bore size (mm)	Standard stroke	L	L ₁	LD	LG	LH	LT	LX	LY	LZ	X	Y
		20	10, 15, 20, 25	14.5	28.5	6.6	4	24	3.2	48	42	62
25	50, 75, 100	15	32.5	6.6	4	26	3.2	52	46	66	10.7	5.8

Foot bracket material: Carbon steel
Surface treatment: Nickel plated

Compact Foot

Bore size (mm)	Standard stroke	With head end lock			With rod end lock		
		A	B	LS	A	B	LS
20	10, 15, 20, 25	99	61	87.4	92.5	54.5	80.9
	50, 75, 100	104	66	92.4	104	66	92.4
25	10, 15, 20, 25	102	64	90.4	95.5	57.5	83.9
	50, 75, 100	107	69	95.4	107	69	95.4

Bore size (mm)	Standard stroke	L	L ₁	LD	LH	LT	LX	LY	LZ	X	Y
		20	10, 15, 20, 25	14.5	28.5	6.6	24	3.2	25.5	42	36
25	50, 75, 100	15	32.5	6.6	26	3.2	28	46	40	13.2	5.8

Compact foot bracket material: Carbon steel
Surface treatment: Zinc chromated

Rod Flange

Bore size (mm)	Standard stroke	With head end lock		With rod end lock	
		A	B	A	B
20	10, 15, 20, 25	75.5	61	69	54.5
	50, 75, 100	80.5	66	80.5	66
25	10, 15, 20, 25	79	64	72.5	57.5
	50, 75, 100	84	69	84	69

Bore size (mm)	Standard stroke	FD	FT	FV	FX	FZ	L	L ₁
		20	10, 15, 20, 25	6.6	8	39	48	60
25	50, 75, 100	6.6	8	42	52	64	15	32.5

Flange bracket material: Carbon steel
Surface treatment: Nickel plated

Head Flange

Bore size (mm)	Standard stroke	With head end lock				With rod end lock			
		A	B	L	L ₁	A	B	L	L ₁
20	10, 15, 20, 25	73.5	61	4.5	18.5	67	54.5	4.5	18.5
	50, 75, 100	88.5	66	14.5	28.5	88.5	66	14.5	28.5
25	10, 15, 20, 25	77	64	5	22.5	70.5	57.5	5	22.5
	50, 75, 100	92	69	15	32.5	92	69	15	32.5

Bore size (mm)	Standard stroke	FD	FT	FV	FX	FZ
		20	10, 15, 20, 25	6.6	8	39
25	50, 75, 100	6.6	8	42	52	64

Flange bracket material: Carbon steel
Surface treatment: Nickel plated

Standard

Large Bore Size

Long Stroke

Non-rotating Rod

Axial Piping

Anti-lateral Load

With End Lock

Water Resistant

With Auto Switch

Auto Switch

Made to Order

Series CBQ2

Double clevis: CBQ2D/CDBQ2D

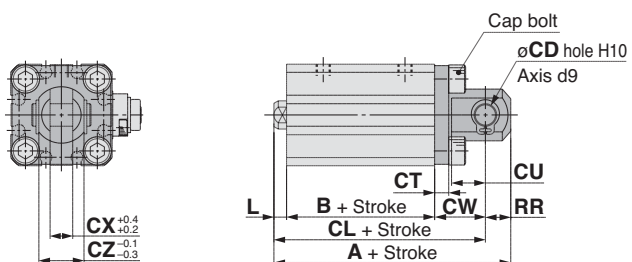

Rod end male thread

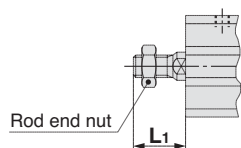

Double Clevis

(mm)

Bore size (mm)	Standard stroke	With head end lock					With rod end lock				
		A	B	CL	L	L ₁	A	B	CL	L	L ₁
20	10, 15, 20, 25	92.5	61	83.5	4.5	18.5	86	54.5	77	4.5	18.5
	50, 75, 100	107.5	66	98.5	14.5	28.5	107.5	66	98.5	14.5	28.5
25	10, 15, 20, 25	99	64	89	5	22.5	92.5	57.5	82.5	5	22.5
	50, 75, 100	114	69	104	15	32.5	114	69	104	15	32.5

Bore size (mm)	Standard stroke	CD	CT	CU	CW	CX	CZ	RR
20	10, 15, 20, 25	8	5	12	18	8	16	9
25	50, 75, 100	10	5	14	20	10	20	10

Double clevis bracket material: Carbon steel
Surface treatment: Nickel plated

Series CBQ2

Dimensions

∅32 to ∅100

Standard (Through-hole): CBQ2B/CDBQ2B
 Both ends tapped: CBQ2A/CDBQ2A

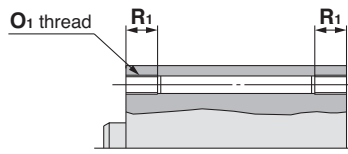

Both Ends Tapped (mm)

Bore size (mm)	O1	R1
32	M6 x 1.0	10
40	M6 x 1.0	10
50	M8 x 1.25	14
63	M10 x 1.5	18
80	M12 x 1.75	22
100	M12 x 1.75	22

With rod end lock

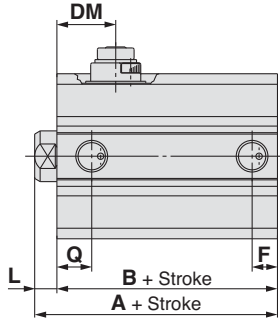

With head end lock

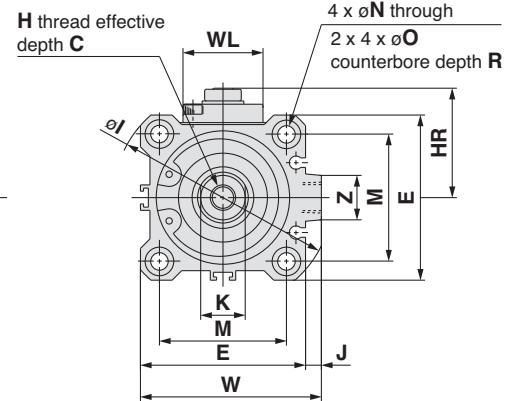
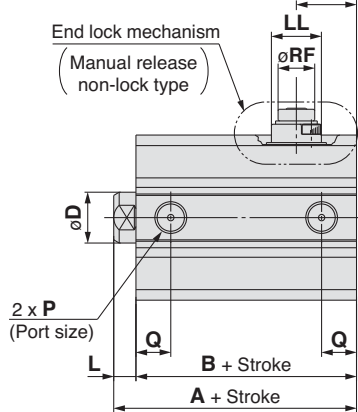

End Lock Mechanism Dimensions (mm)

Bore size (mm)	DL	DM	HR	HN (Max.)	LL	MO	WL	RF
32	25	22	33.5	45	15	15	24	11
40	29	26	38.5	52.5	21	19	24	11
50	29.5	24	45	59	21	19	24	11
63	28.5	25	50	64	21	19	24	11
80	45	45.5	62	76.5	30	23	40	21
100	48	49	71.5	86	30	23	40	21

End lock mechanism (Manual release lock type)

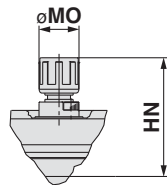

Cylinder tube form ∅63, ∅80, ∅100

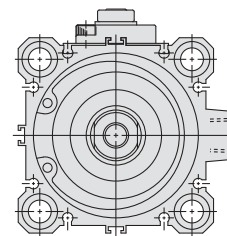

Rod End Male Thread (mm)

Bore size (mm)	Standard stroke	C1	X	H1	L1
32	10, 15, 20, 25	20.5	23.5	M14 x 1.5	28.5
40		20.5	23.5	M14 x 1.5	28.5
50		26	28.5	M18 x 1.5	33.5
63	50, 75, 100	26	28.5	M18 x 1.5	33.5
80	25, 50	32.5	35.5	M22 x 1.5	43.5
	75, 100				53.5
100	25, 50	32.5	35.5	M26 x 1.5	43.5
	75, 100				53.5

Rod end male thread

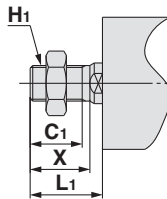

Bore size (mm)	Standard stroke	C	D	E	H	I	J	K	M	N	O	P	R	W	Z
32	10, 15, 20, 25	13	16	45	M8 x 1.25	60	4.5	14	34	5.5	9	Rc1/8	7	49.5	14
40		13	16	52	M8 x 1.25	69	5	14	40	5.5	9	Rc1/8	7	57	14
50		15	20	64	M10 x 1.5	86	7	17	50	6.6	11	Rc1/4	8	71	19
63	50, 75, 100	15	20	77	M10 x 1.5	103	7	17	60	9	14	Rc1/4	10.5	84	19
80	25, 50, 75, 100	21	25	98	M16 x 2.0	132	6	22	77	11	17.5*	Rc3/8	13.5*	104	26
100		27	30	117	M20 x 2.5	156	6.5	27	94	11	17.5*	Rc3/8	13.5*	123.5	26

* At the 75 and 100 mm strokes with ∅80, ∅100, both ends tapped (A) is the standard. Through-hole (B) is not available.

With Head End Lock (mm)

Bore size (mm)	Standard stroke	A	B	L	Q
32	10, 15, 20, 25	72.5	65.5	7	12.5
40		82	75	7	14
50		83.5	75.5	8	14
63	50, 75, 100	85	77	8	15.5
80	25, 50	121	111	10	18
	75, 100	136	116	20	19
100	25, 50	132.5	120.5	12	22
	75, 100	147.5	125.5	22	23

With Rod End Lock (mm)

Bore size (mm)	Standard stroke	A	B	F	L	Q
32	10, 15, 20, 25	65	58	7.5	7	10.5
40		71.5	64.5	8	7	11
50		73.5	65.5	10.5	8	10.5
63	50, 75, 100	79	71	10.5	8	15
80	25, 50	113.5	103.5	12.5	10	16
	75, 100	136	116	19	20	19
100	25, 50	125	113	13	12	23
	75, 100	147.5	125.5	23	22	23

Series CBQ2

Foot: CBQ2L/CDBQ2L

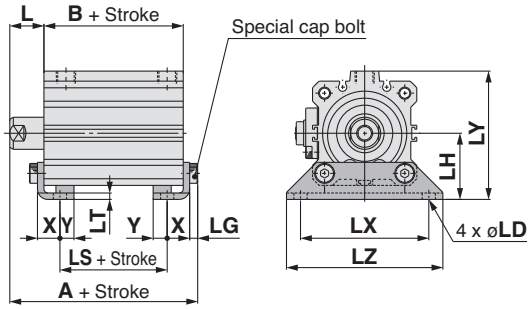

Rod end male thread

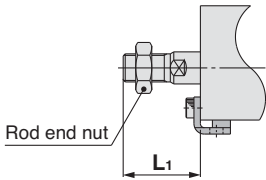

Foot

(mm)

Bore size (mm)	Standard stroke	With head end lock			With rod end lock			L	L ₁	LD
		A	B	LS	A	B	LS			
32		89.7	65.5	49.5	82.2	58	42	17	38.5	6.6
40	10, 15, 20, 25 50, 75, 100	99.2	75	59	88.7	64.5	48.5	17	38.5	6.6
50		101.7	75.5	52.5	91.7	65.5	42.5	18	43.5	9
63		103.2	77	51	97.2	71	45	18	43.5	11
80	25, 50	142.5	111	81	135	103.5	73.5	20	53.5	13
	75, 100	147.5	116	86	147.5	116	86			
100	25, 50	155.5	120.5	86.5	148	113	79	22	53.5	13
	75, 100	160.5	125.5	91.5	160.5	125.5	91.5			

Bore size (mm)	Standard stroke	LG	LH	LT	LX	LY	LZ	X	Y
32		4	30	3.2	57	57	71	11.2	5.8
40	10, 15, 20, 25 50, 75, 100	4	33	3.2	64	64	78	11.2	7
50		5	39	3.2	79	78	95	14.7	8
63		5	46	3.2	95	91.5	113	16.2	9
80	25, 50, 75, 100	7	59	4.5	118	114	140	19.5	11
100		7	71	6	137	136	162	23	12.5

Foot bracket material: Carbon steel
Surface treatment: Nickel plated

Compact foot: CBQ2LC/CDBQ2LC

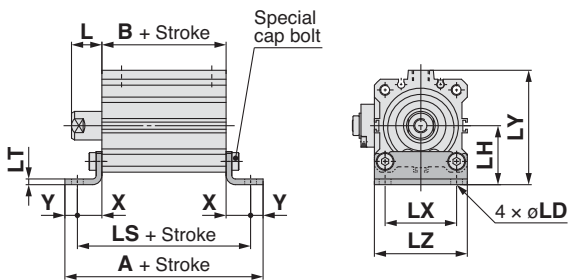

Rod end male thread

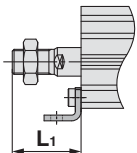

Compact Foot

(mm)

Bore size (mm)	Standard stroke	With head end lock			With rod end lock			L	L ₁	LD
		A	B	LS	A	B	LS			
32		104.5	65.5	92.9	97	58	85.4	17	38.5	6.6
40	10, 15, 20, 25 50, 75, 100	116.4	75	102.4	105.9	64.5	91.9	17	38.5	6.6
50		124.9	75.5	108.9	114.9	65.5	98.9	18	43.5	9
63		131.4	77	113.4	125.4	71	107.4	18	43.5	11
80	25, 50	178	111	156	170.5	103.5	148.5	20	53.5	13
	75, 100	183	116	161	183	116	161			
100	25, 50	193.5	120.5	168.5	186	113	161	22	53.5	13
	75, 100	198.5	125.5	173.5	198.5	125.5	173.5			

Bore size (mm)	Standard stroke	LH	LT	LX	LY	LZ	X	Y
32		30	3.2	34	57	45	13.7	5.8
40	10, 15, 20, 25 50, 75, 100	33	3.2	40	64	52	13.7	7
50		39	3.2	50	78	64	16.7	8
63		46	3.2	60	91.5	77	18.2	9
80	25, 50, 75, 100	59	4.5	77	114	98	22.5	11
100		71	6	94	136	117	24	12.5

Compact foot bracket material: Carbon steel
Surface treatment: Zinc chromated

Rod flange: CBQ2F/CDBQ2F

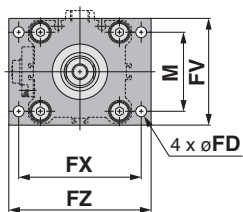
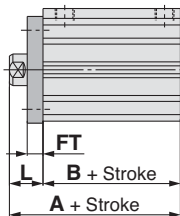

Rod end male thread

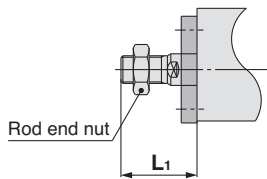

Rod Flange

(mm)

Bore size (mm)	Standard stroke	With head end lock		With rod end lock		FD	FT	FV	FX	FZ
		A	B	A	B					
32		82.5	65.5	75	58	5.5	8	48	56	65
40	10, 15, 20, 25	92	75	81.5	64.5	5.5	8	54	62	72
50	50, 75, 100	93.5	75.5	83.5	65.5	6.6	9	67	76	89
63		95	77	89	71	9	9	80	92	108
80	25, 50	131	111	123.5	103.5	11	11	99	116	134
	75, 100	136	116	136	116					
100	25, 50	142.5	120.5	135	113	11	11	117	136	154
	75, 100	147.5	125.5	147.5	125.5					

Bore size (mm)	Standard stroke	L	L ₁	M
32		17	38.5	34
40	10, 15, 20, 25	17	38.5	40
50	50, 75, 100	18	43.5	50
63		18	43.5	60
80	25, 50, 75, 100	20	53.5	77
100		22	53.5	94

Flange bracket material: Carbon steel
Surface treatment: Nickel plated

- Standard
- Large Bore Size
- Long Stroke
- Non-rotating Rod
- Axial Piping
- Anti-lateral Load
- With End Lock
- Water Resistant
- With Auto Switch
- Auto Switch
- Made to Order

Series CBQ2

Dimensions

Ø32 to Ø100

Head flange: CBQ2G/CDBQ2G

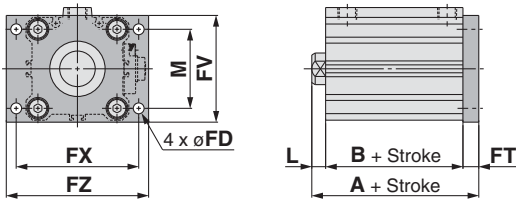

Rod end male thread

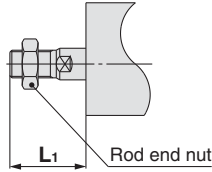

Head Flange

(mm)

Bore size (mm)	Standard stroke	With head end lock				With rod end lock			
		A	B	L	L ₁	A	B	L	L ₁
32	10, 15, 20, 25 50, 75, 100	80.5	65.5	7	28.5	73	58	7	28.5
40		90	75	7	28.5	79.5	64.5	7	28.5
50		92.5	75.5	8	33.5	82.5	65.5	8	33.5
63		94	77	8	33.5	88	71	8	33.5
80	25, 50	132	111	10	43.5	124.5	103.5	10	43.5
	75, 100	147	116	20	53.5	147	116	20	53.5
100	25, 50	143.5	120.5	12	43.5	136	113	12	43.5
	75, 100	158.5	125.5	22	53.5	158.5	125.5	22	53.5

Bore size (mm)	Standard stroke	M	FD	FT	FV	FX	FZ
32	10, 15, 20, 25 50, 75, 100	34	5.5	8	48	56	65
40		40	5.5	8	54	62	72
50		50	6.6	9	67	76	89
63		60	9	9	80	92	108
80		77	11	11	99	116	134
100		94	11	11	117	136	154

Flange bracket material: Carbon steel
Surface treatment: Nickel plated

Double clevis: CBQ2D/CDBQ2D

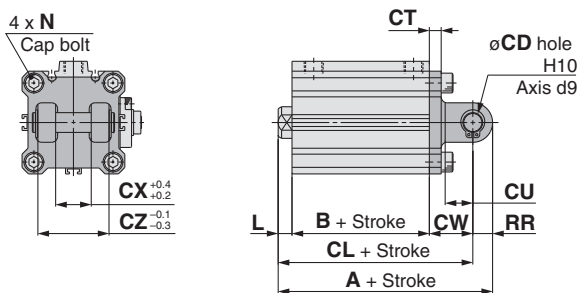

Rod end male thread

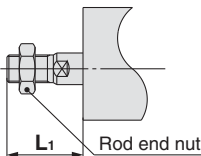

Double Clevis

(mm)

Bore size (mm)	Standard stroke	With head end lock			With rod end lock			CD	CT	CU	L	L ₁
		A	B	CL	A	B	CL					
32	10, 15, 20, 25 50, 75, 100	102.5	65.5	92.5	95	58	85	10	5	14	7	28.5
40		114	75	104	103.5	64.5	93.5	10	6	14	7	28.5
50		125.5	75.5	111.5	115.5	65.5	101.5	14	7	20	8	33.5
63		129	77	115	123	71	109	14	8	20	8	33.5
80	25, 50	177	111	159	169.5	103.5	151.5	18	10	27	10	43.5
	75, 100	192	116	174	192	116	174				20	53.5
100	25, 50	199.5	120.5	177.5	192	113	170	22	13	31	12	43.5
	75, 100	214.5	125.5	192.5	214.5	125.5	192.5				22	53.5

Bore size (mm)	Standard stroke	CW	CX	CZ	N	RR
32	10, 15, 20, 25 50, 75, 100	20	18	36	M6 x 1.0	10
40		22	18	36	M6 x 1.0	10
50		28	22	44	M8 x 1.25	14
63		30	22	44	M10 x 1.5	14
80		38	28	56	M12 x 1.75	18
100		45	32	64	M12 x 1.75	22

Double clevis bracket material: Cast iron
Surface treatment: Painted

Use the Recommended Pneumatic Circuit

⚠ Caution

- This is necessary for the correct locking and unlocking actions.

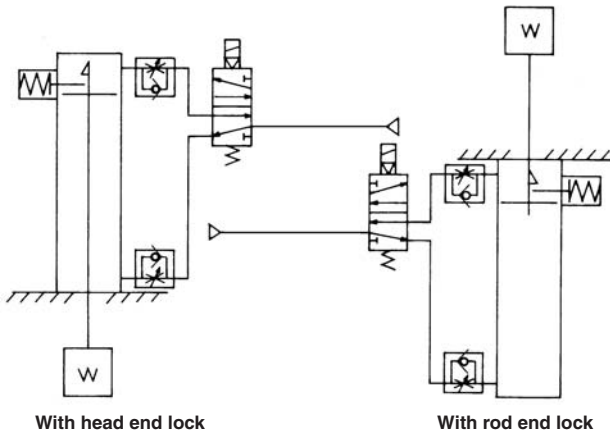

Operating Precautions

⚠ Caution

- Do not use 3-position solenoid valves.**
Avoid use in combination with 3-position solenoid valves (especially closed center metal seal types). If pressure is trapped in the port on the lock mechanism side, the cylinder cannot be locked. Furthermore, even after being locked, the lock may be released after some time, due to air leaking from the solenoid valve and entering the cylinder.
- Back pressure is required for releasing the lock.**
Before starting operation, be sure to control the system so that air is supplied to the side without the lock mechanism as shown in the above figure. There is a possibility that the lock may not be released. (Refer to the section on releasing the lock.)
- Release the lock for mounting or adjusting the cylinder.**
If mounting or other work is performed when the cylinder is locked, the lock unit may be damaged.
- Operate with a load ratio of 50% or less.**
If the load ratio exceeds 50%, this may cause problems such as failure of the lock to release, or damage to the lock unit.
- Do not operate multiple cylinders in synchronisation.**
Avoid applications in which two or more end lock cylinders are synchronised to move one work piece, as one of the cylinder locks may not be able to release when required.
- Use a speed controller with meter-out control.**
Lock cannot be released occasionally by meter-in control.
- Be sure to operate completely to the cylinder stroke end on the side with the lock.**
If the cylinder piston does not reach the end of stroke, locking and unlocking may not be possible.
- Adjust the position of an auto switch, so that it could work at the both positions where it is distanced from the stroke and a backlash (2 mm).**
When a 2-colour indication switch is adjusted for green indication at the stroke end, it may change to red for the backlash return, but this is not abnormal.

Operating Pressure

⚠ Caution

1. Supply air pressure of 0.15 MPa or higher to the port on the side that has the lock mechanism, as it is necessary for releasing the lock.

Exhaust Speed

⚠ Caution

1. When the pressure on the side with the lock mechanism drops to 0.05 MPa or below, the lock engages automatically. If the piping on the side with the lock mechanism is thin and long, or if the speed controller is away from the cylinder port, the lock engagement may take some time due to decline of the exhaust speed. The same result will be caused by clogging of the silencer installed at the

Releasing the Lock

⚠ Warning

1. Before releasing the lock, be sure to supply air to the side without the lock mechanism, so that there is no load applied to the lock mechanism when it is released. (Refer to the recommended pneumatic circuits.) If the lock is released when the port on the other side is in an exhaust state, and with a load applied to the lock unit, the lock unit may be subjected to an excessive force and be damaged. Also, it is very dangerous because the piston rod will move suddenly.

Manual Release

⚠ Caution

1. Manual release (Non-lock type)

Insert the accessory bolt from the top of the rubber cap (it is not necessary to remove the rubber cap), and after screwing it into the lock piston, pull it to release the lock. If you stop pulling the bolt, the lock will return to an operational state.

Thread sizes, pulling forces and strokes are as shown below.

Bore size (mm)	Thread size	Pulling force (N)	Stroke (mm)
20, 25, 32	M2.5 x 0.45 x 25 ℓ or more	4.9	2
40, 50, 63	M3 x 0.5 x 30 ℓ or more	10	3
80, 100	M5 x 0.8 x 40 ℓ or more	24.5	3

Remove the bolt for normal operation.
It can cause lock malfunction or faulty release.

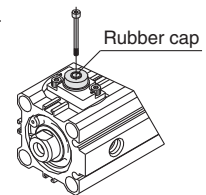

2. Manual release (Lock type)

While pushing the M/O knob, turn it 90° counterclockwise. The lock is released (and remains in a released state) by aligning the ▲ mark on the cap with the ▼ OFF mark on the M/O knob. When locking is desired, turn the M/O knob clockwise 90° while pushing fully, correspond ▲ on cap and ▼ ON mark on the M/O knob. The correct position is confirmed by a click sound "click". If not confirmed, locking is not done.

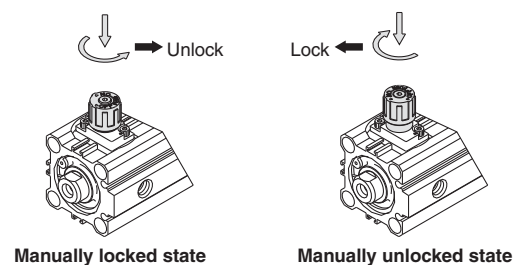

Standard

Large Bore Size

Long Stroke

Non-rotating Rod

Axial Piping

Anti-lateral Load

With End Lock

Water Resistant

With Auto Switch

Auto Switch

Made to Order

With End Lock Series **CDBQ2** With Auto Switch 1

1 Auto Switch Proper Mounting Position (Detection at Stroke End) and its Mounting Height

Applicable Cylinder Series: CDBQ2 (With end lock)

- D-A9□
- D-M9□
- D-M9□W
- D-M9□AL
- D-A9□V
- D-M9□V
- D-M9□WV
- D-M9□AVL

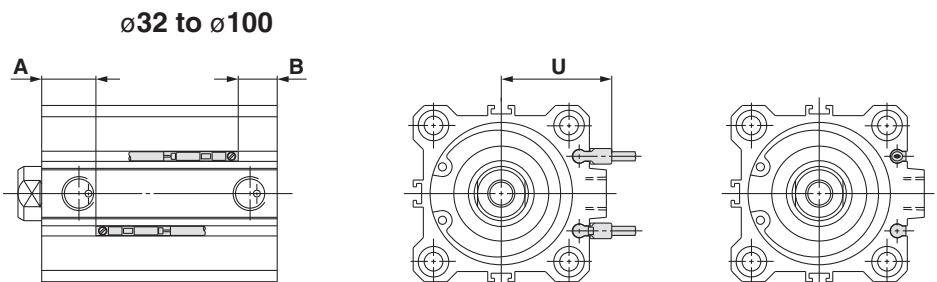
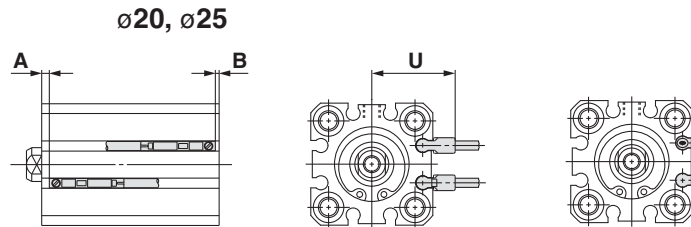

- | | |
|--------|----------|
| D-A7□ | D-F7NTL |
| D-A80 | D-F7BAL |
| D-A7□H | D-A73C |
| D-A80H | D-A80C |
| D-F7□ | D-J79C |
| D-J79 | D-A79W |
| D-F7□W | D-F7□WV |
| D-J79W | D-F7□V |
| D-F79F | D-F7BAVL |

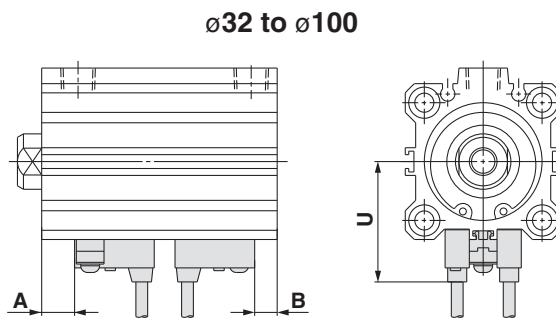

D-P4DWL

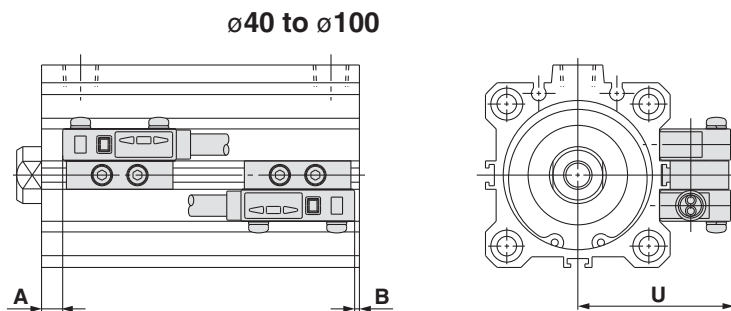

Auto Switch Mounting Height

Applicable Cylinder Series: CDBQ2 (With end lock)

Auto switch model	D-A7□ D-A80		D-A7□H/A80H D-A73C/A80C D-F7□/J79/J79W D-F7□V/J79C D-F7□W/F7□WV D-F7BAL/F7BAVL D-F79F/F7NTL		D-A79W		D-A9□ D-A9□V		D-M9□ D-M9□V D-M9□W D-M9□WV D-M9□AL D-M9□AVL		D-P4DWL	
	A	B	A	B	A	B	A	B	A	B	A	B
20 (Head end lock)	—	—	—	—	—	—	6 (11)	35 (35)	10 (15)	39 (39)	—	—
20 (Rod end lock)	—	—	—	—	—	—	31.5 (34)	3 (12)	35.5 (38)	7 (16)	—	—
25 (Head end lock)	—	—	—	—	—	—	8 (10)	37 (39)	12 (14)	41 (43)	—	—
25 (Rod end lock)	—	—	—	—	—	—	32 (35)	5.5 (14)	36 (39)	9.5 (18)	—	—
32 (Head end lock)	9	38.5	9.5	39	6.5	36	8	37.5	12	41.5	—	—
32 (Rod end lock)	36	4	36.5	4.5	33.5	1.5	35	3	39	7	—	—
40 (Head end lock)	13	44	13.5	44.5	10.5	41.5	12	43	16	47	9	40
40 (Rod end lock)	42	4.5	42.5	5	39.5	2	41	3.5	45	7.5	38	0.5
50 (Head end lock)	11	46.5	11.5	47	8.5	44	10	45.5	14	49.5	7	42.5
50 (Rod end lock)	41.5	6	42	6.5	39	3.5	40.5	5	44.5	9	37.5	2
63 (Head end lock)	13.5	45.5	14	46	11	43	12.5	44.5	16.5	48.5	9.5	41.5
63 (Rod end lock)	45.5	7.5	46	8	43	5	44.5	6.5	48.5	10.5	41.5	3.5
80 (Head end lock)	16.5 (21.5)	76.5 (76.5)	17 (22)	77 (77)	14 (19)	74 (74)	15.5 (20.5)	75.5 (75.5)	19.5 (24.5)	79.5 (79.5)	12.5 (17.5)	72.5 (72.5)
80 (Rod end lock)	66.5 (66.5)	19 (31.5)	67 (67)	19.5 (32)	64 (64)	16.5 (29)	65.5 (65.5)	18 (30.5)	69.5 (69.5)	22 (34.5)	62.5 (62.5)	15 (27.5)
100 (Head end lock)	21 (26)	81.5 (81.5)	21.5 (26.5)	82 (82)	18.5 (23.5)	79 (79)	20 (25)	80.5 (80.5)	24 (29)	84.5 (84.5)	17 (22)	77.5 (77.5)
100 (Rod end lock)	71 (69.5)	24 (38)	71.5 (70)	24.5 (38.5)	68.5 (67)	21.5 (35.5)	70 (68.5)	23 (37)	74 (72.5)	27 (41)	67 (65.5)	20 (34)

Note) The dimensions in () for ø20 and ø25 are for 50, 75 and 100 mm strokes, and the dimensions in () for ø80 and ø100 are for 75 and 100 mm strokes. Adjust the auto switch after confirming the operating conditions in the actual setting.

Applicable Cylinder Series: CDBQ2 (With end lock)

Auto switch model	D-A7□ D-A80	D-A7□H D-A80H/J79W D-F7□/F7BAL D-J79/F79F D-F7□W/F7NTL	D-A73C D-A80C	D-F7□V D-F7□WV D-F7BAVL	D-J79C	D-A79W	D-A9□V	D-M9□V D-M9□WV D-M9□AVL	D-P4DWL
	U	U	U	U	U	U	U	U	U
20	—	—	—	—	—	—	22.5	24.5	—
25	—	—	—	—	—	—	24.5	26.5	—
32	31.5	32.5	38.5	35	38	34	27	29	—
40	35	36	42	38.5	41.5	37.5	30.5	32.5	44
50	41	42	48	44.5	47.5	43.5	36.5	38.5	50
63	47.5	48.5	54.5	51	54	50	40	42	56.5
80	57.5	58.5	64.5	61	64	60	50	52	66.5
100	67.5	68.5	74.5	71	74	70	60	62	76.5

Standard
Large Bore Size
Long Stroke
Non-rotating Rod
Axial Piping
Anti-lateral Load
With End Lock
Water Resistant
With Auto Switch
Auto Switch
Made to Order

With End Lock Series CDBQ2 With Auto Switch 2

2 Minimum Stroke for Auto Switch Mounting

Applicable Cylinder Series: CDBQ2 (With end lock)

(mm)

Number of auto switches	D-M9□V D-F7□V D-J79C	D-A9□V D-A7□ D-A80 D-A73C D-A80C	D-A9□	D-M9□WV D-M9□AVL D-F7□WV D-F7BAVL	D-M9□ D-M9□W D-M9□AL D-A7□H D-A80H D-F7□ D-J79	D-A79W	D-F7□W D-J79W D-F7BAL D-F79F D-F7NTL	D-P4DWL
With 1 pc.	5	5	10	10	15	15	20	15
With 2 pcs.	5	10	10	15	15	20	20	15

3 Operating Range

Applicable Cylinder Series: CDBQ2 (With end lock)

(mm)

Auto switch model	Bore size							
	20	25	32	40	50	63	80	100
D-A9□(V)	10	10	9.5 (9.5)	9.5 (9.5)	9.5 (8.5)	11.5 (11)	9 (10)	11.5 (10.5)
D-M9□(V) D-M9□W(V) D-M9□A(V)L	5.5	5.5	6 (5.5)	6 (5.5)	7 (6)	7.5 (6.5)	8 (7)	8.5 (7)
D-A7□(H)(C) D-A80□(H)(C)	—	—	12	11	10	12	12	13
D-A79W	—	—	13	14	14	16	15	17
D-F7□(V) D-J79(C) D-F7□W(V) D-F7BA(V)L D-F7NTL D-F79F	—	—	6	6	6	6.5	6.5	7
D-P4DWL	—	—	—	5	5	5	5	5.5

* Values which include hysteresis are for guideline purposes only, they are not a guarantee (assuming approximately ±30% dispersion) and may change substantially depending on the ambient environment.

* The values for ø32 or more of the D-A9□(V)/M9□(V)/M9□W(V)/M9□A(V)L types indicate the operating range when the conventional switch installation groove is attached without using the auto switch mounting bracket BQ2-012.

* The values in () for ø32 or more of the D-A9□(V)/M9□(V)/M9□W(V)/M9□A(V)L types indicate the operating range when the auto switch mounting bracket BQ2-012 is used.

4 Auto Switch Mounting Brackets/Part No.

Applicable Cylinder Series: CDBQ2 (With end lock)

Auto switch mounting surface	Bore size (mm)		
	ø20, ø25	ø32, ø40, ø50	ø63, ø80, ø100
Auto switch model	Auto switch mounting surface Port/A/B/C side	Auto switch mounting surface Port side	Auto switch mounting surface A/B/C side
D-A9□ D-A9□V D-M9□ D-M9□V D-M9□W D-M9□WV D-M9□AL D-M9□AVL	Auto switch mounting brackets are not required.	Auto switch mounting brackets are not required.	① BQ-2 ② BQ2-012 Two kinds of auto switch brackets are used as a set.
			Auto switch mounting brackets are not required.

Note 1) When a compact auto switch is mounted on the three sides (A, B and C above) other than the port side of ø32 to ø50 cylinders, auto switch mounting brackets shown above are required. Order them separately from cylinders. (The above is also applicable when a compact auto switch is mounted using an auto switch mounting rail, but not using a compact auto switch installation groove for ø63 to ø100 cylinders.)

Ordering example
 CDBQ2B32-50D-M9BW.....1 pc.
 BQ-2.....2 pcs.
 BQ2-012.....2 pcs.

Note 2) When shipping cylinders, auto switch mounting brackets and auto switches are shipped together.

Auto switch model	Bore size (mm)					
	32	40	50	63	80	100
D-A7□/A80 D-A73C/A80C D-A7□H/A80H D-A79W D-F7□/J79 D-F7□V D-J79C D-F7□W/J79W D-F7□WV D-F7BAL/F7BAVL D-F79F/F7NTL			BQ-2			
D-P4DWL	—					BQP1-050

Note 3) When shipping cylinders, auto switch mounting brackets and auto switches are shipped together.

Note 4) Refer to pages 1360 to 1362 in Best Pneumatics No. 2 for further information on auto switch mounting method.

[Stainless Steel Mounting Screw Kit]

The following stainless steel mounting screw kit (with nuts) is available. Use it in accordance with the operating environment. (Since auto switch spacer (for BQ-2) is not included, order BQ-2 separately.)

BBA2: For D-A7/A8/F7/J7 types

The above stainless steel mounting screws are used when a cylinder is shipped with the D-F7BAL/F7BAVL auto switches.

When only an auto switch is shipped independently, BBA2 is attached.

Note 5) Refer to page 1361 in Best Pneumatics No. 2 for details of BBA2.

Note 6) When the D-M9□A(V)L type is mounted on a port side other than ø32, ø40 or ø50, order auto switch mounting brackets BQ2-012S, BQ-2 or the stainless steel mounting screw kit BBA2 separately.

Auto Switch Mounting Bracket/Weight

Mounting bracket part no.	Weight (g)
BQ-2	1.5
BQ2-012	5
BQP1-050	16

Standard
Large Bore Size
Long Stroke
Non-rotating Rod
Axial Piping
Anti-lateral Load
With End Lock
Water Resistant
With Auto Switch
Auto Switch
Made to Order

With End Lock

Series CDBQ2

With Auto Switch 3

Other than the applicable auto switches listed in “How to Order”, the following auto switches are mountable. Refer to Best Pneumatics No. 2 for detailed specifications.

Applicable Cylinder Series: CDBQ2 (With end lock)

Auto switch type	Model	Electrical entry	Features	Applicable bore size
Reed	D-A73	Grommet (Perpendicular)	—	ø32 to ø100
	D-A80		Without indicator light	
	D-A73H, A76H	Grommet (In-line)	—	
	D-A80H		Without indicator light	
Solid state	D-F7NV, F7PV, F7BV	Grommet (Perpendicular)	—	ø32 to ø100
	D-F7NWV, F7BWV		Diagnostic indication (2-colour indication)	
	D-F7BAVL		Water resistant (2-colour indication)	
	D-F79, F7P, J79	Grommet (In-line)	—	
	D-F79W, F7PW, J79W		Diagnostic indication (2-colour indication)	
	D-F7BAL		Water resistant (2-colour indication)	
	D-F7NTL		With timer	
	D-P5DWL	Grommet (In-line)	Magnetic field resistant (2-colour indication)	

- * With pre-wired connector is also available for solid state auto switches. For details, refer to Best Pneumatics No. 2.
- * Normally closed (NC = b contact) solid state auto switches (D-F9G/F9H) are also available. For details, refer to Best Pneumatics No. 2.
- * When using a magnetic field resistant solid state auto switch D-P3DW□ type, please contact SMC separately. (Applicable bore size: ø32 to ø100)
- * Heat resistant solid state auto switch (D-F7NJL) is not applicable.
- * Regarding the D-P5DWL, please contact SMC separately.

Compact Cylinder: Water Resistant Double Acting, Single Rod Series CQ2

ø20, ø25, ø32, ø40, ø50, ø63, ø80, ø100

How to Order

Without auto switch
ø20, ø25

CQ2 B 20 R - 30 D

Without auto switch
ø32 to ø100

CQ2 B 32 R - 30 D Z

With auto switch

CDQ2 B 32 R - 30 D Z - M9BA

With auto switch
(Built-in magnet)

Mounting		(ø20 to ø100)
B	Through-hole (Standard)	(ø40 to ø100)
A	Both ends tapped	
L	Foot	
LC	Compact foot	
F	Rod flange	
G	Head flange	
D	Double clevis	

* Mounting brackets are shipped together, (but not assembled).
* Cylinder mounting bolts are not included. Order them separately referring to "Mounting Bolt for C(D)Q2B" on pages 180 and 182.

Bore size

20	20 mm
25	25 mm
32	32 mm
40	40 mm
50	50 mm
63	63 mm
80	80 mm
100	100 mm

Port thread type

-	M thread
-	Rc
TN	NPT
TF	G

Number of auto switches

-	2 pcs.
S	1 pc.
n	"n" pcs.

Made to Order

Refer to the next page for details.

Auto switch

-	Without auto switch
---	---------------------

* Refer to the below table for applicable auto switches.

Auto switch mounting groove

Z	ø20 to ø25	2 surfaces
	ø32 to ø100	4 surfaces

Body option

-	Standard (Rod end female thread)
M	Rod end male thread

Action

D	Double acting
---	---------------

Cylinder stroke (mm)

For "Standard Strokes", refer to the next page.

Water resistant cylinder

R	NBR seal (Nitrile rubber)
V	FKM seal (Fluororubber)

Built-in Magnet Cylinder Model

If a built-in magnet cylinder without an auto switch is required, there is no need to enter the symbol for the auto switch.

(Example) CDQ2B32R-25DMZ

Applicable Auto Switches

Refer to pages 1263 to 1371 in Best Pneumatics No. 2 for further information on auto switches.

Type	Special function	Electrical entry	Indicator light	Wiring (Output)	Load voltage		Auto switch model		Lead wire length (m)				Pre-wired connector	Applicable load		
					DC	AC	Perpendicular	In-line	0.5 (-)	1 (M)	3 (L)	5 (Z)		IC circuit	Relay, PLC	
Solid state auto switch	Water resistant (2-colour indication)	Grommet	Yes	3-wire (NPN)	24 V	5 V, 12 V	-	M9NAV	M9NA	○	○	●	○	○	-	-
				3-wire (PNP)				M9PAV	M9PA	○	○	●	○	○		
				2-wire				M9BAV	M9BA	○	○	●	○	○		

* Lead wire length symbols: 0.5 m - (Example) M9BA
1 m M (Example) M9BAM
3 m L (Example) M9BAL
5 m Z (Example) M9BAZ

* Solid state auto switches marked with "○" are produced upon receipt of order.

* For details about auto switches with pre-wired connector, refer to pages 1328 and 1329 in Best Pneumatics No. 2.

Standard

Large Bore Size

Long Stroke

Non-rotating Rod

Axial Piping

Anti-lateral Load

With End Lock

Water Resistant

With Auto Switch

Auto Switch

Made to Order

Series CQ2



JIS Symbol
Double acting,
Single rod

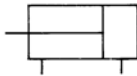

Made to Order
(For details, refer to pages 201 to 235.)

Symbol	Specifications
-XC6	Piston rod/Retaining ring/Rod end nut material: Stainless steel

Refer to pages 193 to 199 for the specifications of cylinders with autoswitches.

- Auto switch proper mounting position (detection at stroke end) and its mounting height
- Minimum stroke for auto switch mounting
- Operating range
- Auto switch mounting brackets/Part no.

Specifications

Bore size (mm)	20	25	32	40	50	63	80	100
Action	Double acting, Single rod							
Fluid	Air							
Proof pressure	1.5 MPa							
Maximum operating pressure	1.0 MPa							
Minimum operating pressure	0.08 MPa							
Ambient and fluid temperature	Without auto switch: -10 to 70°C (No freezing) With auto switch: -10 to 60°C (No freezing)							
Lubrication	Not required (Non-lube)							
Piston speed	50 to 500 mm/s							
Allowable kinetic energy (J)	0.055	0.09	0.15	0.26	0.46	0.77	1.36	2.27
Stroke length tolerance	+1.0 mm 0							

Standard Strokes

Bore size	Standard stroke (mm)
20, 25	5, 10, 15, 20, 25, 30, 35, 40, 45, 50
32, 40	5, 10, 15, 20, 25, 30, 35, 40, 45, 50, 75, 100
50, 63, 80, 100	10, 15, 20, 25, 30, 35, 40, 45, 50, 75, 100

Manufacture of Intermediate Strokes

Type	A spacer is installed in the standard stroke body.	
Part no.	Refer to "How to Order" for the standard model number. (P. 178)	
Description	Strokes in 1 mm intervals are available by installing a spacer in the standard stroke cylinder.	
Stroke range	Bore size	Stroke range
	20, 25	1 to 49
	32 to 100	1 to 99
Example	Part no.: CQ2B50R-57DZ CQ2B50R-75DZ with 18 mm width spacer inside The B dimension is 115.5 mm.	

Type

		Bore size (mm)	20	25	32	40	50	63	80	100	
Pneumatic	Mounting	Through-hole (Standard)	●	●	●	●	●	●	●	●	
		Both ends tapped	—	—	—	●	●	●	●	●	
	Built-in magnet		●	●	●	●	●	●	●	●	
	Piping	Pipe thread	—	M5	M5	^{Note)} M5 Rc1/8	Rc1/8	Rc1/4	Rc1/4	Rc3/8	Rc3/8
			TN	—	—	NPT1/8	NPT1/8	NPT1/4	NPT1/4	NPT3/8	NPT3/8
			TF	—	—	G1/8	G1/8	G1/4	G1/4	G3/8	G3/8
Rod end male thread		●	●	●	●	●	●	●	●	●	

Note) $\phi 32$ without auto switch: M5 x 0.8 is used for 5 mm stroke/piping dimension.
Thus, do not enter a symbol for the port thread type.

Theoretical Output



Bore size (mm)	Operating direction	Operating pressure (MPa)		
		0.3	0.5	0.7
20	IN	71	118	165
	OUT	94	157	220
25	IN	113	189	264
	OUT	147	245	344
32	IN	181	302	422
	OUT	241	402	563
40	IN	317	528	739
	OUT	377	628	880
50	IN	495	825	1150
	OUT	589	982	1370
63	IN	841	1400	1960
	OUT	935	1560	2180
80	IN	1360	2270	3170
	OUT	1510	2510	3520
100	IN	2140	3570	5000
	OUT	2360	3930	5500

Mounting Brackets/Part No.

Bore size (mm)	Foot ^{Note 1)}	Compact Foot ^{Note 1)}	Flange	Double clevis
40	CQ-L040	CQ-LC040	CQ-F040	CQ-D040
50	CQ-L050	CQ-LC050	CQ-F050	CQ-D050
63	CQ-L063	CQ-LC063	CQ-F063	CQ-D063
80	CQ-L080	CQ-LC080	CQ-F080	CQ-D080
100	CQ-L100	CQ-LC100	CQ-F100	CQ-D100

Note 1) When ordering a foot and compact foot brackets, order 2 pieces per cylinder.
Note 2) Parts belonging to each bracket are as follows.

Foot, Compact foot, Flange: Body mounting bolts
Double clevis: Clevis pin, Type C retaining rings for axis, Body mounting bolts

Mounting Bolt for CQ2B/Without Auto Switch

Mounting method: Mounting bolt for through-hole mounting of the CQ2B is available as an option. Refer to the following for ordering procedures. Order the actual number of bolts that will be used.

Example) CQ-M5 x 35L 2 pcs.

Material: Chromium molybdenum steel
Surface treatment: Zinc chromated

Cylinder model	C	D	Mounting bolt part no.
CQ2B20 ^ø -5D	7.5	35	CQ-M5 x 35L
-10D		40	x 40L
-15D		45	x 45L
-20D		50	x 50L
-25D		55	x 55L
-30D		60	x 60L
-35D		65	x 65L
-40D		70	x 70L
-45D		75	x 75L
-50D		80	x 80L
CQ2B25 ^ø -5D	9.5	40	CQ-M5 x 40L
-10D		45	x 45L
-15D		50	x 50L
-20D		55	x 55L
-25D		60	x 60L
-30D		65	x 65L
-35D		70	x 70L
-40D		75	x 75L
-45D		80	x 80L
-50D		85	x 85L
CQ2B32 ^ø -5D	9	40	CQ-M5 x 40L
-10DZ		45	x 45L
-15DZ		50	x 50L
-20DZ		55	x 55L
-25DZ		60	x 60L
-30DZ		65	x 65L
-35DZ		70	x 70L
-40DZ		75	x 75L
-45DZ		80	x 80L
-50DZ		85	x 85L

Cylinder model	C	D	Mounting bolt part no.
CQ2B40 ^ø -5DZ	7.5	35	CQ-M5 x 35L
-10DZ		40	x 40L
-15DZ		45	x 45L
-20DZ		50	x 50L
-25DZ		55	x 55L
-30DZ		60	x 60L
-35DZ		65	x 65L
-40DZ		70	x 70L
-45DZ		75	x 75L
-50DZ		80	x 80L
CQ2B50 ^ø -10DZ	12.5	45	CQ-M6 x 45L
-15DZ		50	x 50L
-20DZ		55	x 55L
-25DZ		60	x 60L
-30DZ		65	x 65L
-35DZ		70	x 70L
-40DZ		75	x 75L
-45DZ		80	x 80L
-50DZ		85	x 85L
-75DZ		120	x 120L
CQ2B63 ^ø -10DZ	14.5	50	CQ-M8 x 50L
-15DZ		55	x 55L
-20DZ		60	x 60L
-25DZ		65	x 65L
-30DZ		70	x 70L
-35DZ		75	x 75L
-40DZ		80	x 80L
-45DZ		85	x 85L
-50DZ		90	x 90L
-75DZ		125	x 125L
-100DZ	150	x 150L	

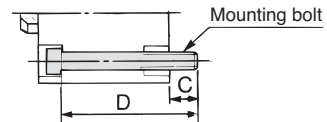

Cylinder model	C	D	Mounting bolt part no.
CQ2B80 ^ø -10DZ	15	55	CQ-M10 x 55L
-15DZ		60	x 60L
-20DZ		65	x 65L
-25DZ		70	x 70L
-30DZ		75	x 75L
-35DZ		80	x 80L
-40DZ		85	x 85L
-45DZ		90	x 90L
-50DZ		95	x 95L
-75DZ		130	x 130L
CQ2B100 ^ø -10DZ	15.5	65	CQ-M10 x 65L
-15DZ		70	x 70L
-20DZ		75	x 75L
-25DZ		80	x 80L
-30DZ		85	x 85L
-35DZ		90	x 90L
-40DZ		95	x 95L
-45DZ		100	x 100L
-50DZ		105	x 105L
-75DZ		140	x 140L
-100DZ	165	x 165L	

Weight

Weight Without Auto Switch

Stroke	(g)											
	5	10	15	20	25	30	35	40	45	50	75	100
Bore size												
ø20	112	126	141	155	169	184	198	212	227	241	—	—
ø25	149	165	182	197	213	229	245	261	277	293	—	—
ø32	203	224	246	267	288	309	330	352	373	394	544	650
ø40	220	241	263	284	306	327	349	371	392	414	568	680
ø50	—	378	411	444	476	509	542	575	608	641	879	1051
ø63	—	547	585	623	662	700	738	776	814	852	1125	1321
ø80	—	973	1034	1094	1154	1214	1275	1335	1395	1455	1873	2169
ø100	—	1703	1783	1863	1944	2024	2104	2185	2265	2345	2915	3323

Additional Weight

Bore size (mm)	20	25	32	40	50	63	80	100
Both ends tapped	—	—	—	6	6	19	45	45
Rod end male thread	Male thread		6	12	26	27	53	53
	Nut		4	8	17	17	32	32
Foot (Including mounting bolts)	—	—	—	154	243	320	690	1057
Compact foot (Including mounting bolts)	—	—	—	114	177	241	501	770
Rod flange (Including mounting bolts)	—	—	—	214	373	559	1056	1365
Head flange (Including mounting bolts)	—	—	—	198	348	534	1017	1309
Double clevis (Including pin, retaining rings, bolts)	—	—	—	196	393	554	1109	1887

Calculation: (Example) CQ2D40R-20DMZ

- Basic weight: CQ2B40R-20DZ 284 g
- Additional weight: Both ends tapped 6 g
- Rod end male thread 44 g
- Double clevis 196 g

530 g

Add each weight of auto switches when auto switches are mounted.

Standard
Large Bore Size
Long Stroke
Non-rotating Rod
Axial Piping
Anti-lateral Load
With End Lock
Water Resistant
With Auto Switch
Auto Switch
Made to Order

Construction

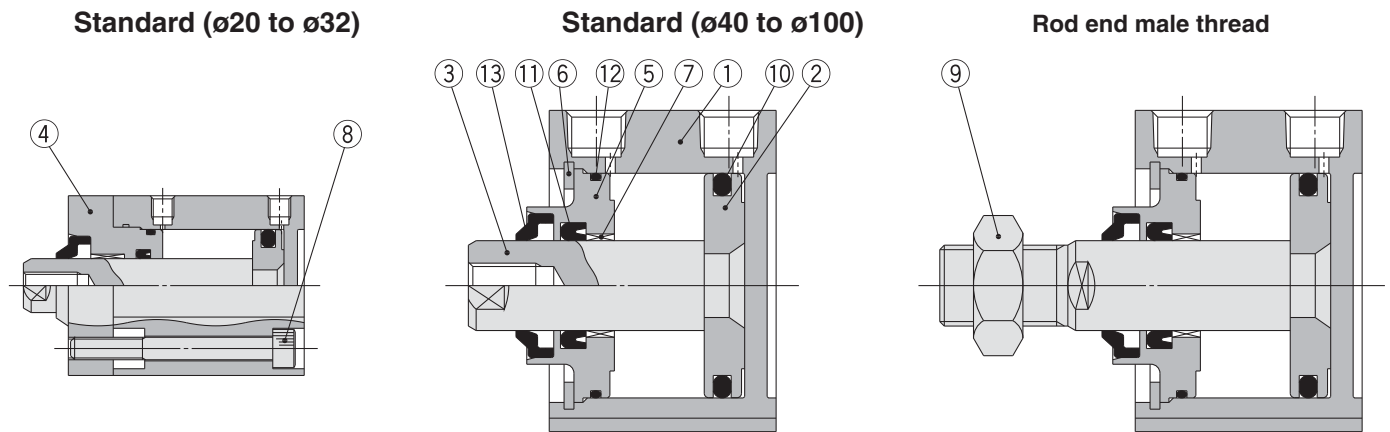

Component Parts

No.	Description	Material	Note
1	Cylinder tube	Aluminum alloy	Hard anodised
2	Piston	Aluminum alloy	Chromated
3	Piston rod	Stainless steel	ø20 to ø25
		Carbon steel	ø32 to ø100, Hard chrome plated
4	Rod cover	Aluminum alloy	ø20 to ø32, Anodised
5	Collar	Aluminum alloy	ø40 to ø100, Anodised
6	Retaining ring	Carbon tool steel	ø40 to ø100, Phosphate coated
7	Bushing	Oil-impregnated sintered alloy	ø20, ø25
		Bearing alloy	ø32 to ø100
8	Hexagon socket head cap screw	Chromium molybdenum steel	ø20 to ø32, Nickel plated
9	Rod end nut	Carbon steel	Nickel plated
10	Piston seal	R: NBR	
		V: FKM	
11	Rod seal	R: NBR	
		V: FKM	
12	Tube gasket	R: NBR	
		V: FKM	
13	Rod scraper	R: NBR	
		V: FKM	

* R: NBR seal (Nitrile rubber) V: FKM seal (Fluororubber)

Replacement Parts/Seal Kit

Bore size (mm)	Kit no.		Contents
	R: NBR	V: FKM	
20	CQ2B20R-PS	CQ2B20V-PS	Kits include items ⑩, ⑪, ⑫ from the table.
25	CQ2B25R-PS	CQ2B25V-PS	
32	CQ2B32R-PS	CQ2B32V-PS	
40	CQ2B40R-PS	CQ2B40V-PS	
50	CQ2B50R-PS	CQ2B50V-PS	
63	CQ2B63R-PS	CQ2B63V-PS	
80	CQ2B80R-PS	CQ2B80V-PS	
100	CQ2B100R-PS	CQ2B100V-PS	

- * Seal kit includes ⑩, ⑪, ⑫. Order the seal kit, based on each bore size.
 - * A rod scraper cannot be replaced independently. It is press-fitted, so replace it not only with a rod cover and collar, but also with a rod cover assembly and collar assembly. Contact SMC separately for how to order them.
 - * Since the seal kit does not include a grease pack, order it separately.
- Grease pack part no.: GR-S-010 (10 g)**

Retaining Ring Installation/Removal

⚠ Caution

- For installation and removal, use an appropriate pair of pliers (tool for installing a type C retaining ring).
- Even if a proper plier (tool for installing a type C retaining ring) is used, it is likely to inflict damage to a human body or peripheral equipment, as a retaining ring may be flown out of the tip of a plier (tool for installing a type C retaining ring). Be much careful with the popping of a retaining ring. Besides, be certain that a retaining ring is placed firmly into the groove of rod cover before supplying air at the time of installment.

Handling Precautions

⚠ Caution

- Before installing a cylinder, thoroughly flush out the piping to prevent dust or cutting chips from entering the cylinder. For hydraulic cylinders, use the air bleed valve to release the air inside the cylinder.
- Eccentric loads applied to the piston rod dramatically shorten the service life. Use the piston rod by always applying a load in an axial direction.
- Make sure not to scratch or gouge the sliding portion of the piston rod, as this could damage the seals and lead to leakage.

Handling Precautions

⚠ Caution

- When the cylinder is exposed to dust or sand, or is used in a place where liquid from the piston rod splashes, use the heavy-duty scraper (-XC4) type.
- If there is a possibility of liquid splashing on cylinder fittings when using an air cylinder, use insert fittings, self-align fittings, steel piping, etc. Consider the compatibility of liquid components and piping materials before using.
- When selecting seals, generally use NBR (nitrile rubber) seals with liquids that do not contain chlorine and sulfur, and use FKM (fluoro rubber) seals with liquids that contain chlorine and sulfur. However, depending on the type and the brand of liquid (such as coolant liquid) that splashes on the cylinder, the operating life of seals may be reduced dramatically.

Examples of coolant liquid

- Shimiron, PA-O-5 (Daido Chemical Industry Co., Ltd.) (NBR seals)
- Noritake Cool, AFG-S (Noritake Co., Ltd.) (NBR seals)
- Yushiroken, S-46S (Yushiro Chemical Industry Co., Ltd.) (NBR seals)
- Yushiroken, EC-50-T3 (Yushiro Chemical Industry Co., Ltd.) (NBR seals)
- Yushiron Oil, No. 23 (Yushiro Chemical Industry Co., Ltd.) (FKM seals)
- Daphne Cut, Hs-1 (Idemitsu Kosan Co., Ltd.) (FKM seals)

Water Resistant: Double Acting, Single Rod Series CDQ2 With Auto Switch



Weight

Weight

(g)

Stroke Bore size	Stroke											
	5	10	15	20	25	30	35	40	45	50	75	100
ø20	130	142	155	167	179	191	204	216	228	240	—	—
ø25	182	197	213	228	244	259	275	290	306	320	—	—
ø32	263	284	305	327	348	369	390	412	433	454	561	668
ø40	293	315	336	358	379	401	422	444	465	487	598	710
ø50	—	489	522	555	588	620	653	687	720	753	925	1097
ø63	—	700	738	776	814	852	890	928	966	1004	1201	1397
ø80	—	1219	1279	1340	1400	1460	1520	1581	1641	1701	1998	2295
ø100	—	2061	2142	2222	2302	2383	2463	2543	2624	2704	3112	3520

Additional Weight

(g)

Bore size (mm)		20	25	32	40	50	63	80	100
Both ends tapped		—	—	—	6	6	19	45	45
Rod end male thread	Male thread	6	12	26	27	53	53	120	175
	Nut	4	8	17	17	32	32	49	116
Foot (Including mounting bolts)		—	—	—	154	243	320	690	1057
Rod flange (Including mounting bolts)		—	—	—	214	373	559	1056	1365
Head flange (Including mounting bolts)		—	—	—	198	348	534	1017	1309
Double clevis (Including pin, retaining rings, bolts)		—	—	—	196	393	554	1109	1887

Calculation: (Example) **CDQ2D40R-20DMZ**

- Basic weight: CDQ2B40R-20DZ 358 g
- Additional weight: Both ends tapped 6 g
- Rod end male thread ... 44 g
- Double clevis 196 g

Add each weight of auto switches when auto switches are mounted.

604 g

Mounting Bolt for CDQ2B/With Auto Switch

Mounting method: Mounting bolt for through-hole mounting of the CDQ2B is available as an option. Refer to the following for ordering procedures. Order the actual number of bolts that will be used.

Example) CQ-M5 x 50L 2 pcs.

Material: Chromium molybdenum steel
Surface treatment: Zinc chromated

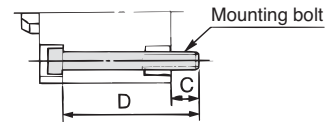

Cylinder model	C	D	Mounting bolt part no.
CDQ2B20 ^ø -5DZ	10.5	50	CQ-M5 x 50L
		55	x 55L
		60	x 60L
		65	x 65L
		70	x 70L
		75	x 75L
		80	x 80L
		85	x 85L
		90	x 90L
		95	x 95L
CDQ2B25 ^ø -5DZ	9.5	50	CQ-M5 x 50L
		55	x 55L
		60	x 60L
		65	x 65L
		70	x 70L
		75	x 75L
		80	x 80L
		85	x 85L
		90	x 90L
		95	x 95L
CDQ2B32 ^ø -5DZ	9	50	CQ-M5 x 50L
		55	x 55L
		60	x 60L
		65	x 65L
		70	x 70L
		75	x 75L
		80	x 80L
		85	x 85L
		90	x 90L
		95	x 95L

Cylinder model	C	D	Mounting bolt part no.
CDQ2B40 ^ø -5DZ	7.5	45	CQ-M5 x 45L
		50	x 50L
		55	x 55L
		60	x 60L
		65	x 65L
		70	x 70L
		75	x 75L
		80	x 80L
		85	x 85L
		90	x 90L
CDQ2B50 ^ø -10DZ	12.5	115	x 115L
		140	x 140L
		55	CQ-M6 x 55L
		60	x 60L
		65	x 65L
		70	x 70L
		75	x 75L
		80	x 80L
		85	x 85L
		90	x 90L
CDQ2B63 ^ø -10DZ	14.5	95	x 95L
		120	x 120L
		145	x 145L
		60	CQ-M8 x 60L
		65	x 65L
		70	x 70L
		75	x 75L
		80	x 80L
		85	x 85L
		90	x 90L
CDQ2B80 ^ø -10DZ	15.5	140	x 140L
		165	x 165L
		75	CQ-M10 x 75L
		80	x 80L
		85	x 85L
		90	x 90L
		95	x 95L
		100	x 100L
		105	x 105L
		110	x 110L

Cylinder model	C	D	Mounting bolt part no.
CDQ2B80 ^ø -10DZ	15	65	CQ-M10 x 65L
		70	x 70L
		75	x 75L
		80	x 80L
		85	x 85L
		90	x 90L
		95	x 95L
		100	x 100L
		105	x 105L
		110	x 110L
CDQ2B100 ^ø -10DZ	15.5	130	x 130L
		155	x 155L
		75	CQ-M10 x 75L
		80	x 80L
		85	x 85L
		90	x 90L
		95	x 95L
		100	x 100L
		105	x 105L
		110	x 110L

Standard

Large Bore Size

Long Stroke

Non-rotating Rod

Axial Piping

Anti-lateral Load

With End Lock

Water Resistant

With Auto Switch

Auto Switch

Made to Order

Series CQ2

Construction

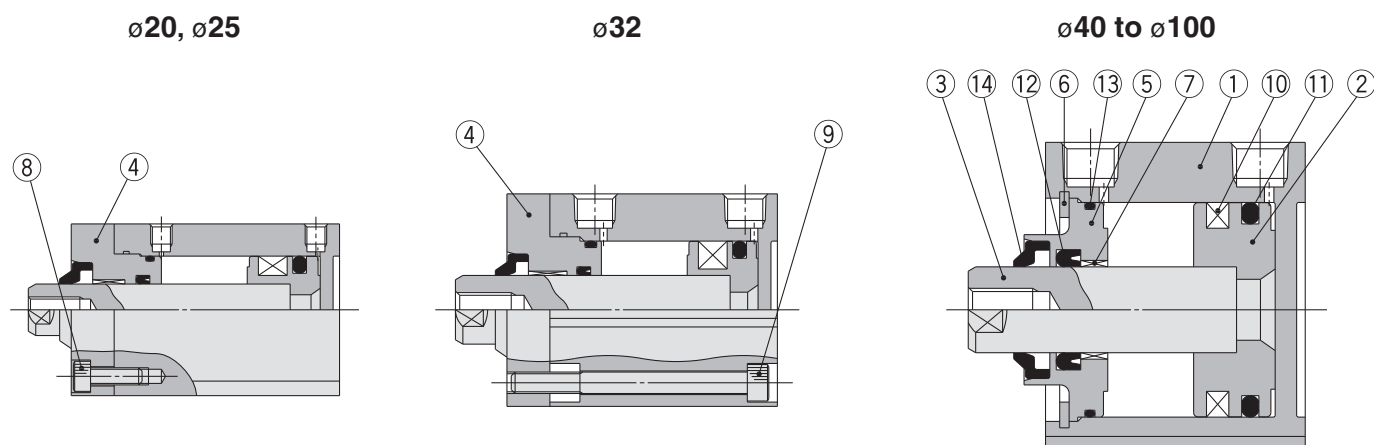

Component Parts

No.	Description	Material	Note
1	Cylinder tube	Aluminum alloy	Hard anodised
2	Piston	Aluminum alloy	Chromated
3	Piston rod	Stainless steel	ø20 to ø25
		Carbon steel	ø32 to ø100, Hard chrome plated
4	Rod cover	Aluminum alloy	ø20 to ø32, Anodised
5	Collar	Aluminum alloy	ø40 to ø100, Anodised
6	Retaining ring	Carbon tool steel	Phosphate coated
7	Bushing	Oil-impregnated sintered alloy	ø20, ø25
		Bearing alloy	ø32 to ø100
8	Hexagon socket head cap screw	Chromium molybdenum steel	ø20 to ø25, Nickel plated
9	Hexagon socket head cap screw	Chromium molybdenum steel	ø32, Nickel plated
10	Magnet	—	
11	Piston seal	R: NBR	
		V: FKM	
12	Rod seal	R: NBR	
		V: FKM	
13	Tube gasket	R: NBR	
		V: FKM	
14	Rod scraper	R: NBR	
		V: FKM	

* R: NBR seal (Nitrile rubber)
V: FKM seal (Fluororubber)

Replacement Parts/Seal Kit

Bore size (mm)	Kit no.		Contents
	R: NBR	V: FKM	
20	CQ2B20R-PS	CQ2B20V-PS	Kits include items ⑪, ⑫, ⑬ from the table.
25	CQ2B25R-PS	CQ2B25V-PS	
32	CQ2B32R-PS	CQ2B32V-PS	
40	CQ2B40R-PS	CQ2B40V-PS	
50	CQ2B50R-PS	CQ2B50V-PS	
63	CQ2B63R-PS	CQ2B63V-PS	
80	CQ2B80R-PS	CQ2B80V-PS	
100	CQ2B100R-PS	CQ2B100V-PS	

* Seal kit includes ⑪, ⑫, ⑬. Order the seal kit, based on each bore size.

* A rod scraper cannot be replaced independently. It is press-fitted, so replace it not only with a rod cover and collar, but also with a rod cover assembly and collar assembly. Contact SMC separately for how to order them.

* Since the seal kit does not include a grease pack, order it separately.

Grease pack part no.: GR-S-010 (10 g)

Dimensions

Ø20, Ø25/Without Auto Switch

Standard (Through-hole): CQ2B

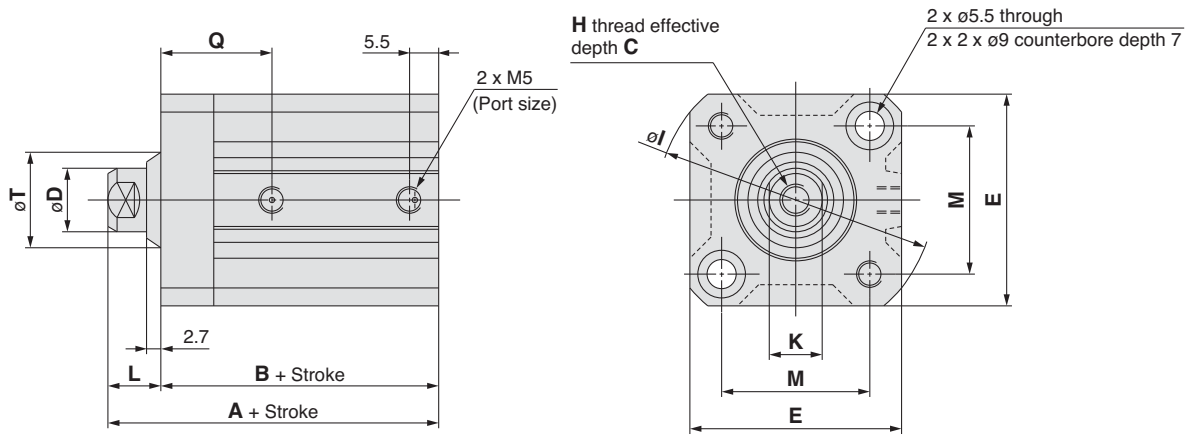

Rod end male thread

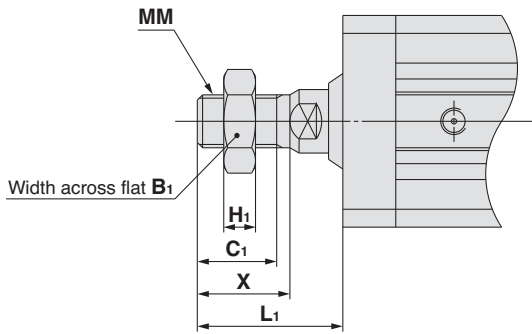

Rod End Male Thread (mm)

Bore size (mm)	B_1	C_1	H_1	L_1	MM	X
20	13	12	5	23.5	M8 x 1.25	14
25	17	15	6	27.5	M10 x 1.25	17.5

Standard

(mm)

Bore size (mm)	Stroke range (mm)	A	B	C	D	E	H	I	K	L	M	Q	T
20	5 to 50	39	29.5	7	10	36	M5 x 0.8	47	8	9.5	25.5	18	16.1
25	5 to 50	42.5	32.5	12	12	40	M6 x 1.0	52	10	10	28	19	18.1

* For details about the rod end nut and accessory brackets, refer to page 23.

* Refer to page 179 for the calculation on the longitudinal dimension of intermediate strokes.

Standard

Large Bore Size

Long Stroke

Non-rotating Rod

Axial Piping

Anti-lateral Load

With End Lock

Water Resistant

With Auto Switch

Auto Switch

Made to Order

Series CQ2

Dimensions

Ø20, Ø25/With Auto Switch

Standard (Through-hole): CDQ2B

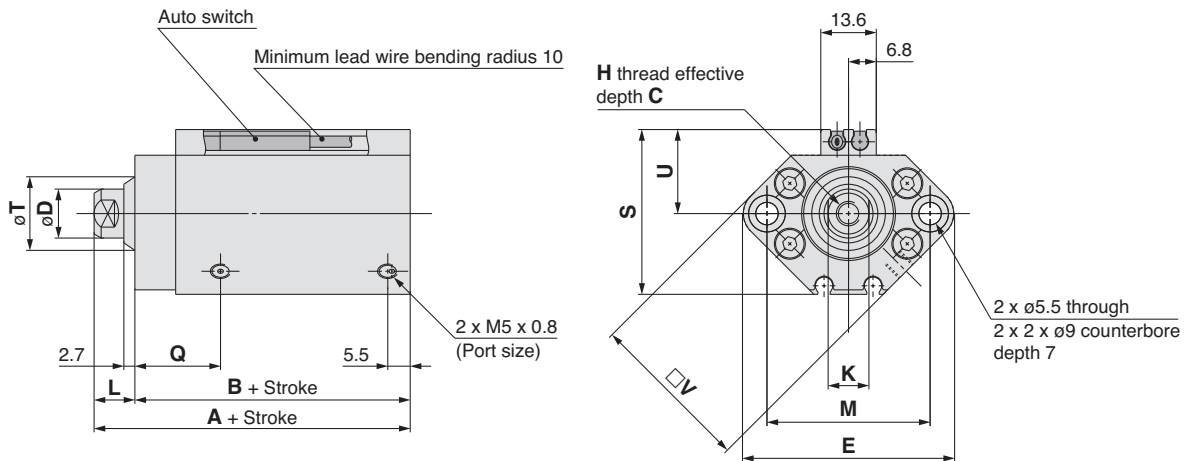

Rod end male thread

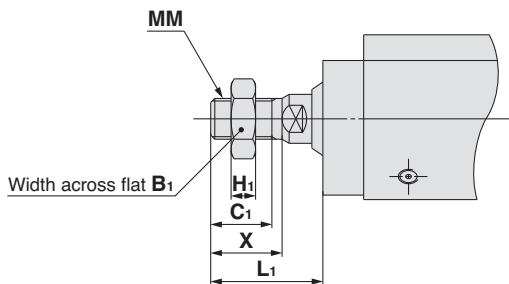

Rod End Male Thread (mm)

Bore size (mm)	B ₁	C ₁	H ₁	L ₁	MM	X
20	13	12	5	23.5	M8 x 1.25	14
25	17	15	6	27.5	M10 x 1.25	17.5

Standard For auto switch proper mounting position and its mounting height, refer to pages 193 to 199. (mm)

Bore size (mm)	Stroke range (mm)	A	B	C	D	E	H	K	L	M	Q	S	T	U	V
20	5 to 50	51	41.5	7	10	47	M5 x 0.8	8	9.5	36	18	35.5	16.1	18	36
25	5 to 50	52.5	42.5	12	12	52	M6 x 1.0	10	10	40	19	40.5	18.1	21	40

* For details about the rod end nut and accessory brackets, refer to page 23.

* Refer to page 179 for the calculation on the longitudinal dimension of intermediate strokes.

Dimensions

Ø32/With Auto Switch

(In the case of without auto switches, the A, B dimensions will be only changed. Refer to the dimension table.)

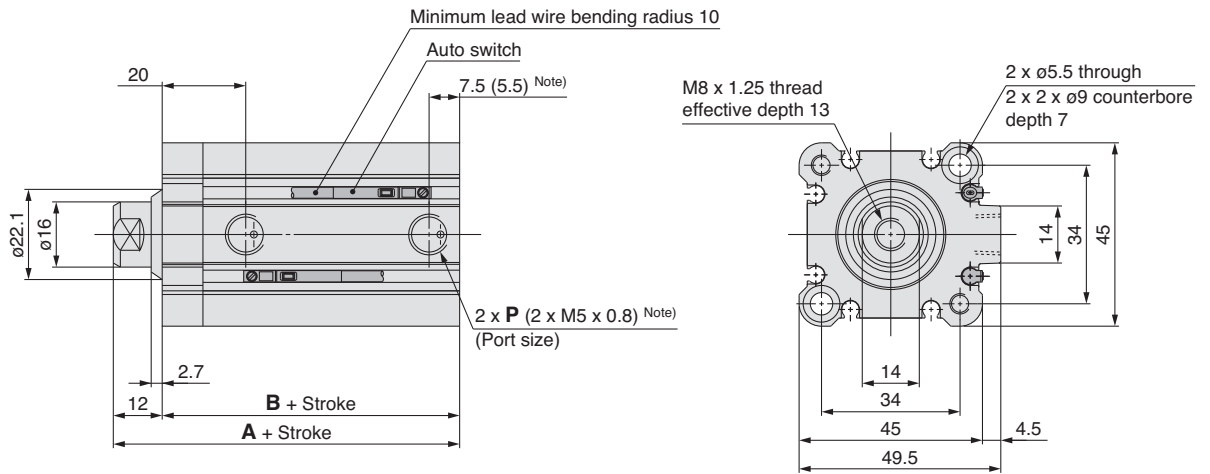

Rod end male thread

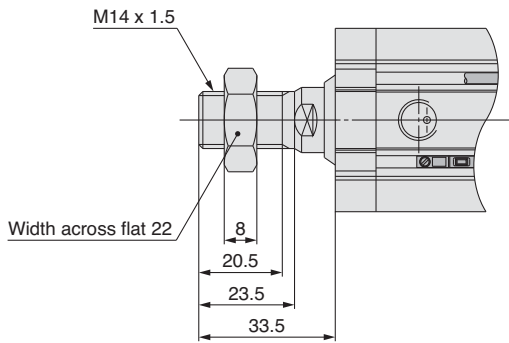

Note) (): Without auto switch, 5 mm strokes

(mm)

Stroke range (mm)	Without auto switch		With auto switch		P		
	A	B	A	B	—	TN	TF
5 to 50	45	33	55	43	Rc1/8	NPT1/8	G1/8
75, 100	55	43					

* For details about the rod end nut and accessory brackets, refer to page 23.

* Refer to page 179 for the calculation on the longitudinal dimension of intermediate strokes.

Standard

Large Bore Size

Long Stroke

Non-rotating Rod

Axial Piping

Anti-lateral Load

With End Lock

Water Resistant

With Auto Switch

Auto Switch

Made to Order

Series CQ2

Dimensions

Ø40, Ø50/With Auto Switch

(In the case of without auto switches, the A, B dimensions will be only changed. Refer to the dimension table.)

Both ends tapped: CQ2A/CDQ2A

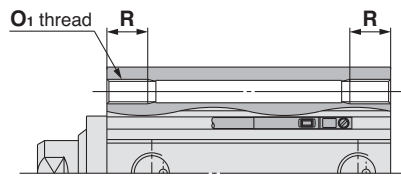

Both Ends Tapped

Bore size (mm)	O ₁	R
40	M6 x 1.0	10
50	M8 x 1.25	14

Standard (Through-hole): CQ2B/CDQ2B

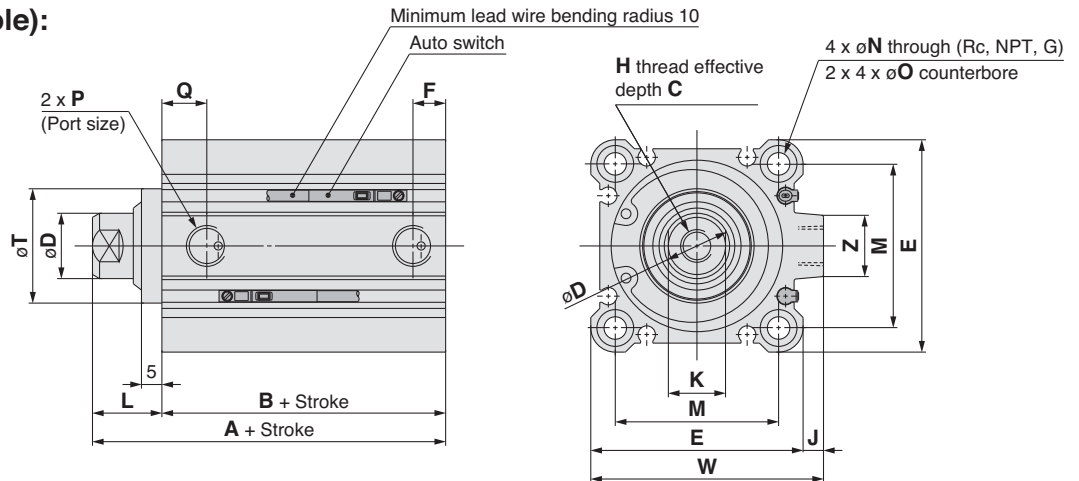

Rod end male thread

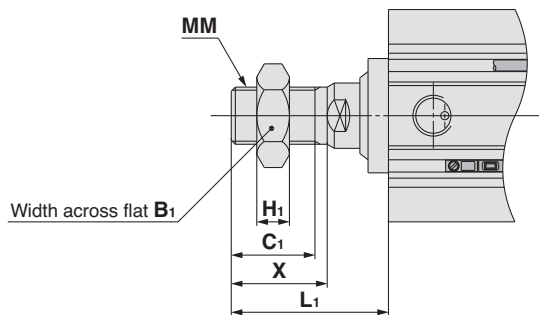

Rod End Male Thread

Bore size (mm)	B ₁	C ₁	H ₁	L ₁	MM	X
40	22	20.5	8	38.5	M14 x 1.5	23.5
50	27	26	11	43.5	M18 x 1.5	28.5

Standard For auto switch proper mounting position and its mounting height, refer to pages 193 to 199.

Bore size (mm)	Stroke range (mm)	Without auto switch		With auto switch		C	D	E	F	H	J	K	L	M	N	O	P	Q	T	W	Z
		A	B	A	B																
40	5 to 50	46.5	29.5	56.5	39.5	13	16	52	7.5	M8 x 1.25	5	14	17	40	5.5	9 depth 7	1/8	12.5	28	57	15
	75, 100	56.5	39.5																		
50	10 to 50	48.5	30.5	58.5	40.5	15	20	64	10.5	M10 x 1.5	7	17	18	50	6.6	11 depth 8	1/4	10.5	35	71	19
	75, 100	58.5	40.5																		

Note 1) For details about the rod end nut and accessory brackets, refer to page 23.

Note 2) Refer to page 179 for the calculation on the longitudinal dimension of intermediate strokes.

Foot: CQ2L/CDQ2L

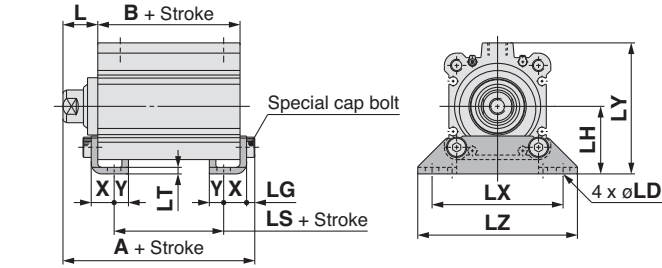

Rod end male thread

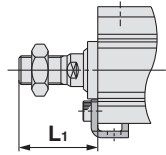

Compact foot: CQ2LC/CDQ2LC

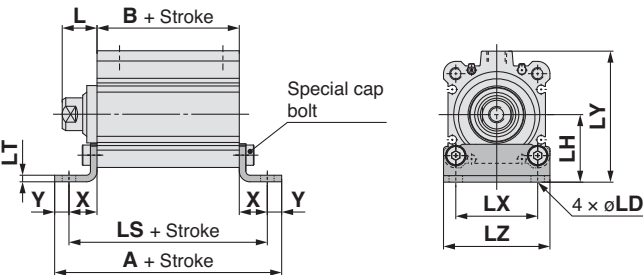

Rod end male thread

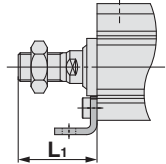

Rod flange: CQ2F/CDQ2F

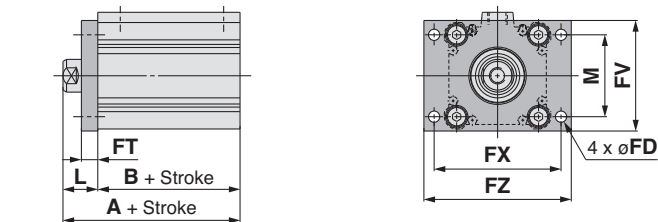

Rod end male thread

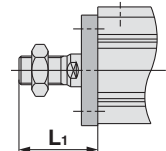

Head flange: CQ2G/CDQ2G

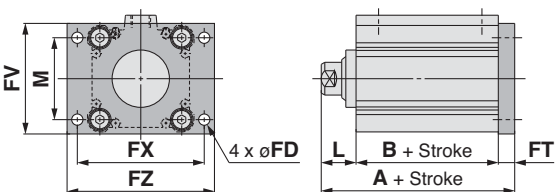

Rod end male thread

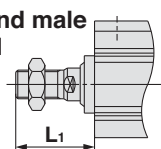

Foot

Bore size (mm)	Stroke range (mm)	Without auto switch			With auto switch			L	L ₁	LD
		A	B	LS	A	B	LS			
40	5 to 50	53.7	29.5	13.5	63.7	39.5	23.5	17	38.5	6.6
	75, 100	63.7	39.5	23.5						
50	10 to 50	56.7	30.5	7.5	66.7	40.5	17.5	18	43.5	9
	75, 100	66.7	40.5	17.5						

Bore size (mm)	LG	LH	LT	LX	LY	LZ	X	Y
40	4	33	3.2	64	64	78	11.2	7
50	5	39	3.2	79	78	95	14.7	8

Foot bracket material: Carbon steel
Surface treatment: Nickel plated

Compact Foot

Bore size (mm)	Stroke range (mm)	Without auto switch			With auto switch			L	L ₁	LD
		A	B	LS	A	B	LS			
40	5 to 50	70.9	29.5	56.9	80.9	39.5	66.9	17	38.5	6.6
	75, 100	80.9	39.5	66.9						
50	10 to 50	79.9	30.5	63.9	89.9	40.5	73.9	18	43.5	9
	75, 100	89.9	40.5	73.9						

Bore size (mm)	LH	LT	LX	LY	LZ	X	Y
40	33	3.2	40	64	52	13.7	7
50	39	3.2	50	78	64	16.7	8

Compact foot bracket material: Carbon steel
Surface treatment: Zinc chromated

Rod Flange

Bore size (mm)	Stroke range (mm)	Without auto switch		With auto switch		FD	FT	FV	FX	FZ
		A	B	A	B					
40	5 to 50	46.5	29.5	56.5	39.5	5.5	8	54	62	72
	75, 100	56.5	39.5							
50	10 to 50	48.5	30.5	58.5	40.5	6.6	9	67	76	89
	75, 100	58.5	40.5							

Bore size (mm)	L	L ₁	M
40	17	38.5	40
50	18	43.5	50

Flange bracket material: Carbon steel
Surface treatment: Nickel plated

Head Flange

Bore size (mm)	Stroke range (mm)	Without auto switch	With auto switch
		A	A
40	5 to 50	54.5	64.5
	75, 100	64.5	
50	10 to 50	57.5	67.5
	75, 100	67.5	

Flange bracket material: Carbon steel
Surface treatment: Nickel plated

* The dimensions except A are the same as those of the rod flange.

Standard
Large Bore Size
Long Stroke
Non-rotating Rod
Axial Piping
Anti-lateral Load
With End Lock
Water Resistant
With Auto Switch
Auto Switch
Made to Order

Series CQ2

Double clevis: CQ2D/CDQ2D

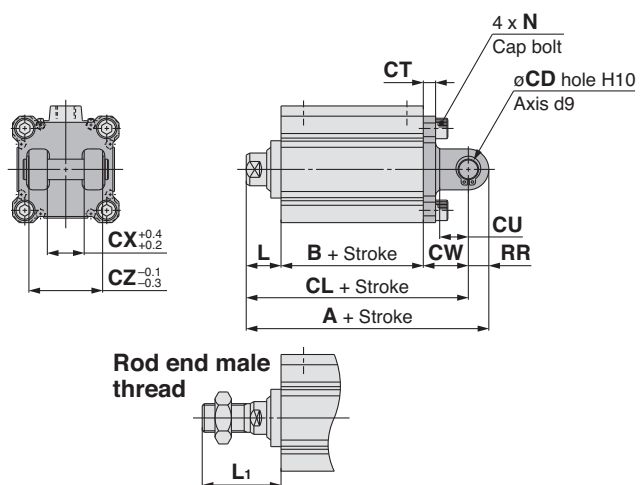

Double Clevis

Bore size (mm)	Stroke range (mm)	Without auto switch			With auto switch			CD	CT	CU
		A	B	CL	A	B	CL			
40	5 to 50	78.5	29.5	68.5	88.5	39.5	78.5	10	6	14
	75, 100	88.5	39.5	78.5						
50	10 to 50	90.5	30.5	76.5	100.5	40.5	86.5	14	7	20
	75, 100	100.5	40.5	86.5						

Bore size (mm)	CW	CX	CZ	L	L ₁	N	RR
40	22	18	36	17	38.5	M6 x 1.0	10
50	28	22	44	18	43.5	M8 x 1.25	14

Double clevis bracket material: Cast iron
Surface treatment: Painted

- * For details about the rod end nut and accessory brackets, refer to page 23.
- * Double clevis pin and retaining rings are included.

Series CQ2

Dimensions

∅63 to ∅100/With Auto Switch

(In the case of without auto switches, the A, B dimensions will be only changed. Refer to the dimension table.)

Both ends tapped: CQ2A/CDQ2A

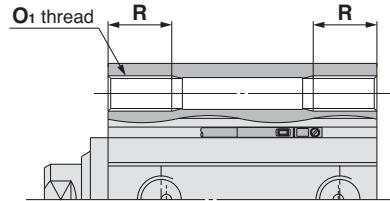

Both Ends Tapped

Bore size (mm)	O ₁	R
63	M10 x 1.5	18
80	M12 x 1.75	22
100	M12 x 1.75	22

Standard (Through-hole): CQ2B/CDQ2B

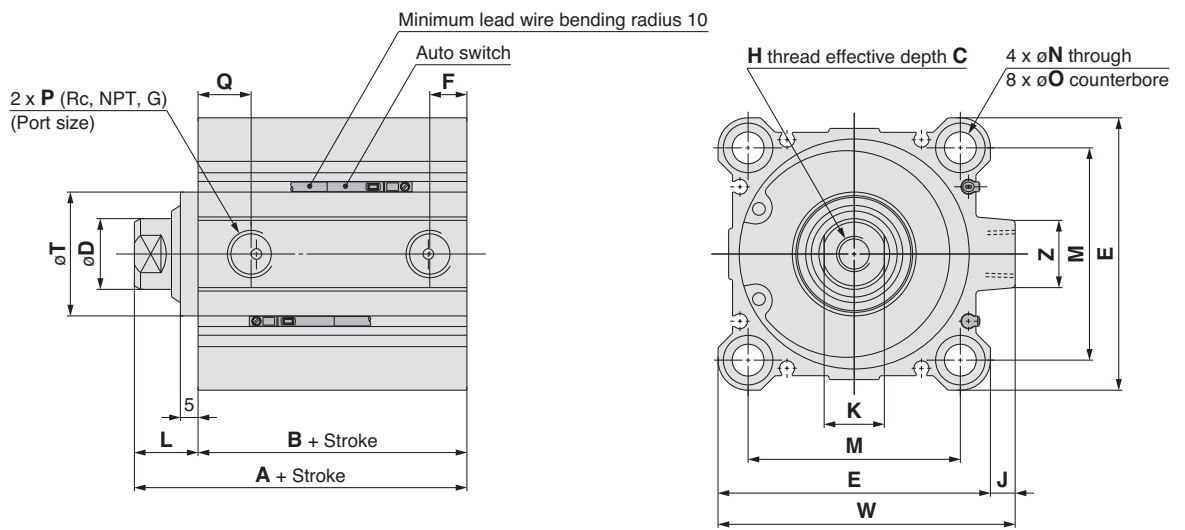

Rod end male thread

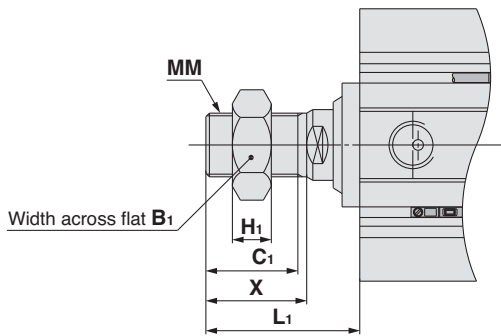

Rod End Male Thread

Bore size (mm)	B ₁	C ₁	H ₁	L ₁	MM	X
63	27	26	11	43.5	M18 x 1.5	28.5
80	32	32.5	13	53.5	M22 x 1.5	35.5
100	41	32.5	16	53.5	M26 x 1.5	35.5

Standard For auto switch proper mounting position and its mounting height, refer to pages 193 to 199.

Bore size (mm)	Stroke range (mm)	Without auto switch		With auto switch		C	D	E	F	H	J	K	L	M	N	O	P	Q	T
		A	B	A	B														
63	10 to 50	54	36	64	46	15	20	77	10.5	M10 x 1.5	7	17	18	60	9	14 depth 10.5	1/4	15	35
	75, 100	64	46																
80	10 to 50	63.5	43.5	73.5	53.5	21	25	98	12.5	M16 x 2.0	6	22	20	77	11	17.5 depth 13.5	3/8	16	43
	75, 100	73.5	53.5																
100	10 to 50	75	53	85	63	27	30	117	13	M20 x 2.5	6.5	27	22	94	11	17.5 depth 13.5	3/8	23	59
	75, 100	85	63																

(mm)

* For details about the rod end nut and accessory brackets, refer to page 23.

Note) Refer to page 179 for the calculation on the longitudinal dimension of intermediate strokes.

Bore size (mm)	W	Z
63	84	19
80	104	25
100	123.5	25

Series CQ2

Foot: CQ2L/CDQ2L

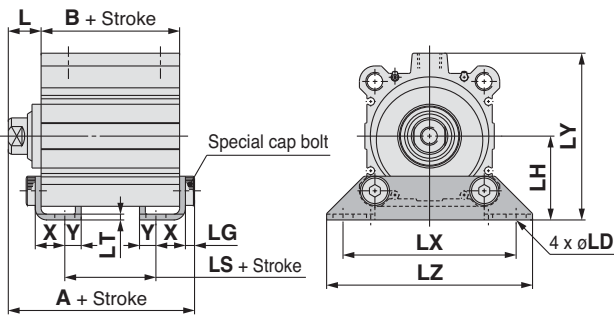

Rod end male thread

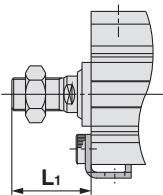

Head flange: CQ2G/CDQ2G

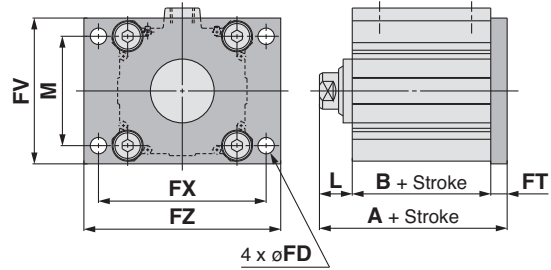

Rod end male thread

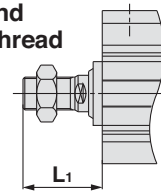

Compact foot: CQ2LC/CDQ2LC

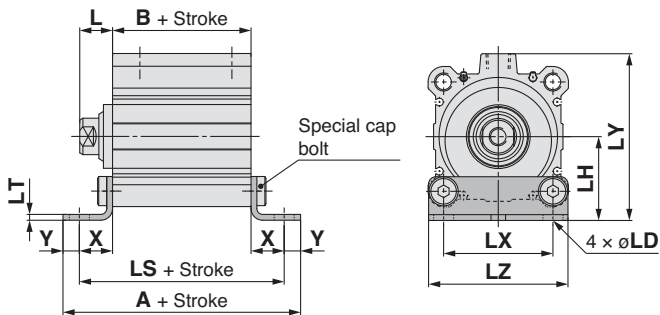

Rod end male thread

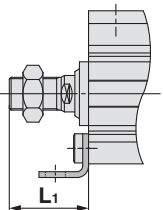

Compact Foot

(mm)

Bore size (mm)	Stroke range (mm)	Without auto switch			With auto switch			L	L ₁	LD	LH	LT	LX
		A	B	LS	A	B	LS						
63	10 to 50	90.4	36	72.4	100.4	46	82.4	18	43.5	11	46	3.2	60
	75, 100	100.4	46	82.4									
80	10 to 50	110.5	43.5	88.5	120.5	53.5	98.5	20	53.5	13	59	4.5	77
	75, 100	120.5	53.5	98.5									
100	10 to 50	126	53	101	136	63	111	22	53.5	13	71	6	94
	75, 100	136	63	111									

Compact foot bracket material: Carbon steel
Surface treatment: Zinc chromated

* For details about the rod end nut and accessory brackets, refer to page 23.

Rod flange: CQ2F/CDQ2F

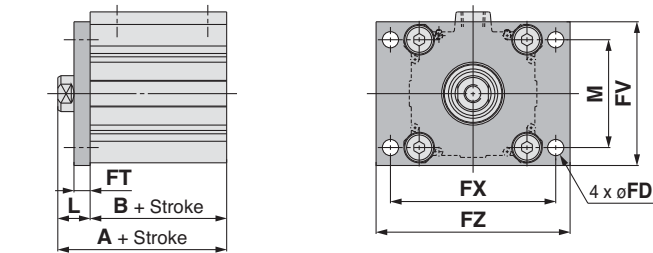

Rod end male thread

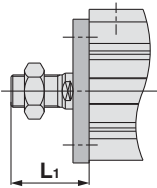

Double clevis: CQ2D/CDQ2D

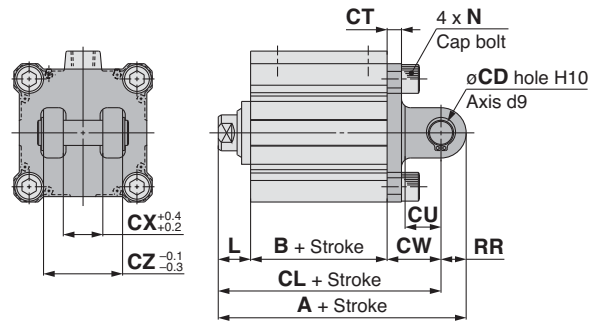

Rod end male thread

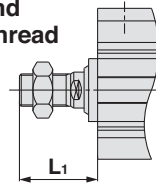

Foot (mm)

Bore size (mm)	Stroke range (mm)	Without auto switch			With auto switch			L	L ₁	LD	LG	LH	LT
		A	B	LS	A	B	LS						
63	10 to 50	62.2	36	10	72.2	46	20	18	43.5	11	5	46	3.2
	75, 100	72.2	46	20									
80	10 to 50	75	43.5	13.5	85	53.5	23.5	20	53.5	13	7	59	4.5
	75, 100	85	53.5	23.5									
100	10 to 50	88	53	19	98	63	29	22	53.5	13	7	71	6
	75, 100	98	63	29									

Foot bracket material: Carbon steel
Surface treatment: Nickel plated

Bore size (mm)	Stroke range (mm)	LX	LY	LZ	X	Y
63	10 to 50	95	91.5	113	16.2	9
	75, 100					
80	10 to 50	118	114	140	19.5	11
	75, 100					
100	10 to 50	137	136	162	23	12.5
	75, 100					

Rod Flange (mm)

Bore size (mm)	Stroke range (mm)	Without auto switch		With auto switch		FD	FT	FV	FX	FZ	L	L ₁	M
		A	B	A	B								
63	10 to 50	54	36	64	46	9	9	80	92	108	18	43.5	60
	75, 100	64	46										
80	10 to 50	63.5	43.5	73.5	53.5	11	11	99	116	134	20	53.5	77
	75, 100	73.5	53.5										
100	10 to 50	75	53	85	63	11	11	117	136	154	22	53.5	94
	75, 100	85	63										

Flange bracket material: Carbon steel
Surface treatment: Nickel plated

Head Flange (mm)

Bore size (mm)	Stroke range (mm)	Without auto switch	With auto switch
		A	A
63	10 to 50	63	73
	75, 100	73	
80	10 to 50	74.5	84.5
	75, 100	84.5	
100	10 to 50	86	96
	75, 100	96	

* The dimensions except A are the same as those of the rod flange.

Flange bracket material: Carbon steel
Surface treatment: Nickel plated

Double Clevis (mm)

Bore size (mm)	Stroke range (mm)	Without auto switch			With auto switch			CD	CT	CU	CW	CX
		A	B	CL	A	B	CL					
63	10 to 50	98	36	84	108	46	94	14	8	20	30	22
	75, 100	108	46	94								
80	10 to 50	119.5	43.5	101.5	129.5	53.5	111.5	18	10	27	38	28
	75, 100	129.5	53.5	111.5								
100	10 to 50	142	53	120	152	63	130	22	13	31	45	32
	75, 100	152	63	130								

Double clevis bracket material: Cast iron
Surface treatment: Painted

Bore size (mm)	Stroke range (mm)	CZ	L	L ₁	N	RR
63	10 to 50	44	18	43.5	M10 x 1.5	14
	75, 100					
80	10 to 50	56	20	53.5	M12 x 1.75	18
	75, 100					
100	10 to 50	64	22	53.5	M12 x 1.75	22
	75, 100					

* For details about the rod end nut and accessory brackets, refer to page 23.
* Double clevis pin and retaining rings are included.

Standard

Large Bore Size

Long Stroke

Non-rotating Rod

Axial Piping

Anti-lateral Load

With End Lock

Water Resistant

With Auto Switch

Auto Switch

Made to Order

Compact Cylinder Series **CDQ2** With Auto Switch 1

1 Auto Switch Proper Mounting Position (Detection at Stroke End) and its Mounting Height

Applicable Cylinder Series: CDQ2, CDQ2W, CDQ2□□□-□S/□T (Single acting), CDQ2, CDQ2W (Large bore size), CDQ2K, CDQ2KW (Non-rotating rod), CDQ2 (Long stroke), CDQ2□S (Anti-lateral load), CDQ2□R/□V (Water resistant)

D-A9□
D-M9□
D-M9□W
D-M9□AL
D-A9□V
D-M9□V
D-M9□WV
D-M9□AVL

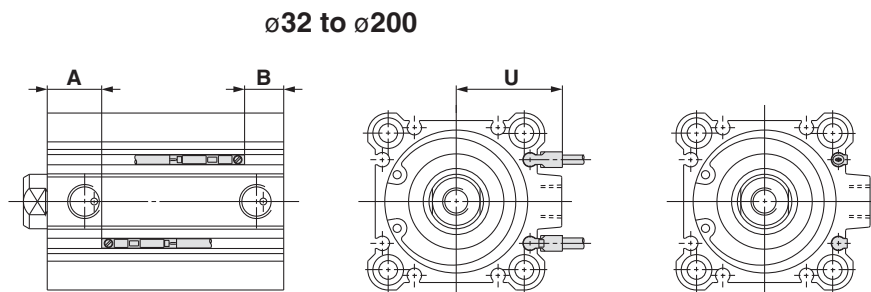
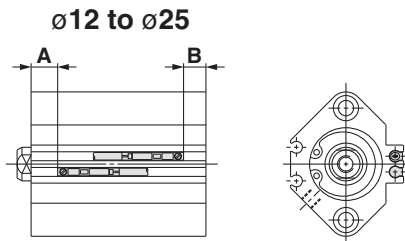

D-A7□
D-A80
D-A7□H
D-A80H
D-F7□
D-J79
D-F7□W
D-J79W
D-F79F

D-F7NTL
D-F7BAL
D-A73C
D-A80C
D-J79C
D-A79W
D-F7□WV
D-F7□V
D-F7BAVL

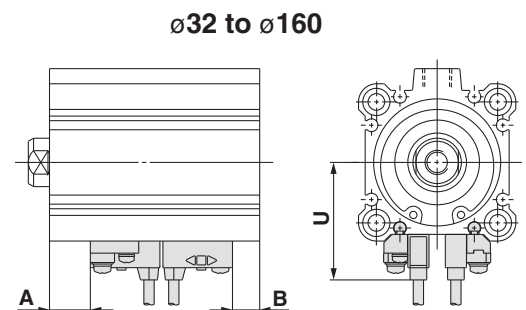
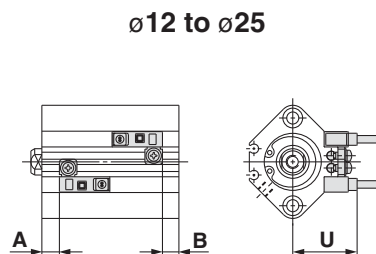

D-P3DW□

ø32 to ø100

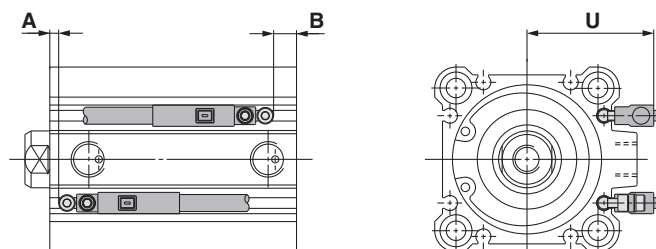

Auto Switch Proper Mounting Position

Applicable Cylinder Series: CDQ2 (Double acting, Single rod)

(mm)

Auto switch model	D-A9□ D-A9□V		D-M9□ D-M9□V D-M9□W D-M9□WV D-M9□AL D-M9□AVL		D-A73 D-A80		D-A72/A7□H/A80H D-A73C/A80C/F7□ D-F79F/J79/F7□V D-J79C/F7□W D-J79W/F7□WV D-F7BAVL/F7BAL		D-F7NTL		D-A79W		D-P3DW□	
	A	B	A	B	A	B	A	B	A	B	A	B	A	B
Bore size														
12	2	3	6	7	4.5	5.5	5	6	10	11	2	3	—	—
16	5	2.5	9	6.5	7.5	5	8	5.5	13	10.5	5	2.5	—	—
20	5	3.5	9	7.5	7.5	6	8	6.5	13	11.5	5	3.5	—	—
25	5.5	4	9.5	8	8	6.5	8.5	7	13.5	12	5.5	4	—	—
32	8	5	12	9	9	6	9.5	6.5	14.5	11.5	6.5	3.5	2.5	0
40	12	7.5	16	11.5	13	8.5	13.5	9	18.5	14	10.5	6	6.5	2
50	10	10.5	14	14.5	11	11.5	11.5	12	16.5	17	8.5	9	4.5	4.5
63	12.5	13.5	16.5	17.5	13.5	14.5	14	15	19	20	11	12	7	7.5
80	15.5	18	19.5	22	16.5	19	17	19.5	22	24.5	14	16.5	10	12
100	20	23	24	27	21	24	21.5	24.5	26.5	29.5	18.5	21.5	14.5	17.5

Applicable Cylinder Series: CDQ2W (Double acting, Double rod)

(mm)

Auto switch model	D-A9□ D-A9□V		D-M9□ D-M9□V D-M9□W D-M9□WV D-M9□AL D-M9□AVL		D-A73 D-A80		D-A72/A7□H/A80H D-A73C/A80C/F7□ D-F79F/J79/F7□V D-J79C/F7□W D-J79W/F7□WV D-F7BAVL/F7BAL		D-F7NTL		D-A79W		D-P3DW□	
	A	B	A	B	A	B	A	B	A	B	A	B	A	B
Bore size														
12	2	7.5	6	11.5	4.5	10	5	10.5	10	15.5	2	7.5	—	—
16	5	8	9	12	7.5	10.5	8	11	13	16	5	8	—	—
20	5	10	9	14	7.5	12.5	8	13	13	18	5	10	—	—
25	5.5	10.5	9.5	14.5	8	13	8.5	13.5	13.5	18.5	5.5	10.5	—	—
32	8	12.5	12	16.5	9	13.5	9.5	14	14.5	19	6.5	11	2.5	7
40	12	18	16	22	13	19	13.5	19.5	18.5	24.5	10.5	16.5	6.5	12.5
50	10	20.5	14	24.5	11	21.5	11.5	22	16.5	27	8.5	19	4.5	14.5
63	12.5	19.5	16.5	23.5	13.5	20.5	14	21	19	26	11	18	7	13.5
80	15.5	25.5	19.5	29.5	16.5	26.5	17	27	22	32	14	24	10	19.5
100	20	30.5	24	34.5	21	31.5	21.5	32	26.5	37	18.5	29	14.5	25

Applicable Cylinder Series: CDQ2□□□-□S/-□T (Single acting)

(mm)

Auto switch model	D-A9□ D-A9□V		D-M9□ D-M9□V D-M9□W D-M9□WV D-M9□AL D-M9□AVL		D-A73 D-A80		D-A72/A7□H/A80H D-A73C/A80C/F7□ D-F79F/J79/F7□V D-J79C/F7□W D-J79W/F7□WV D-F7BAVL/F7BAL		D-F7NTL		D-A79W	
	A	B	A	B	A	B	A	B	A	B	A	B
Bore size												
12	2	3 (7.5)	6	7 (11.5)	4.5	5.5 (10)	5	6 (10.5)	10	11 (15.5)	2	3 (7.5)
16	5 (3)	2.5 (4.5)	9 (7)	6.5 (8.5)	7.5 (5.5)	5 (7)	8 (6)	5.5 (7.5)	13 (11)	10.5 (12.5)	5 (3)	2.5 (4.5)
20	5	3.5	9	7.5	7.5	6	8	6.5	13	11.5	5	3.5
25	5.5	4	9.5	8	8	6.5	8.5	7	13.5	12	5.5	4
32	8	5	12	9	9	6	9.5	6.5	14.5	11.5	6.5	3.5
40	12	7.5	16	11.5	13	8.5	13.5	9	18.5	14	10.5	6
50	10	10.5	14	14.5	11	11.5	11.5	12	16.5	17	8.5	9

() : Spring extend type

Note) Adjust the auto switch after confirming the operating conditions in the actual setting.

Standard

Large Bore Size

Long Stroke

Non-rotating Rod

Axial Piping

Anti-lateral Load

With End Lock

Water Resistant

With Auto Switch

Auto Switch

Made to Order

Compact Cylinder Series CDQ2 With Auto Switch 2

1 Auto Switch Proper Mounting Position (Detection at Stroke End) and its Mounting Height

Auto Switch Proper Mounting Position

Applicable Cylinder Series: CDQ2, CDQ2W (Large bore size)

(mm)

Auto switch model	D-A9□ D-A9□V		D-M9□ D-M9□V D-M9□W D-M9□WV D-M9□AL D-M9□AVL		D-A73 D-A80		D-A72/A7□H/A80H D-A73C/A80C D-F7□/F7□V D-F79F/F7□W D-F7□WV/J79 D-J79W/J79C D-F7BAL D-F7BAVL		D-A79W		D-F7NTL		
	A	B	A	B	A	B	A	B	A	B	A	B	
Bore size													
125	30	30	34	34	32.5	32.5	33	33	30	30	38	38	
140	30	30	34	34	32.5	32.5	33	33	30	30	38	38	
160	34	34	38	38	36.5	36.5	37	37	34	34	42	42	
180	40.5	40.5	44.5	44.5	—	—	—	—	—	—	—	—	
200	43.5	43.5	47.5	47.5	—	—	—	—	—	—	—	—	

Applicable Cylinder Series: CDQ2 (Long stroke)

(mm)

Auto switch model	D-A9□ D-A9□V		D-M9□ D-M9□V D-M9□W D-M9□WV D-M9□AL D-M9□AVL		D-A73 D-A80		D-A72/A7□H/A80H D-A73C/A80C/F7□ D-F79F/J79/F7□V D-J79C/F7□W D-J79W/F7□WV D-F7BAVL/F7BAL		D-F7NTL		D-A79W		D-P3DW□	
	A	B	A	B	A	B	A	B	A	B	A	B	A	B
Bore size														
32	8.5	16.5	12.5	20.5	9.5	17.5	10	18	15	23	7	15	3	11
40	12	22.5	16	26.5	13	23.5	13.5	24	18.5	29	10.5	21	6.5	17
50	10	25.5	14	29.5	11	26.5	11.5	27	16.5	32	8.5	24	4.5	19.5
63	12.5	24.5	16.5	28.5	13.5	25.5	14	26	19	31	11	23	7	18.5
80	15.5	30.5	19.5	34.5	16.5	31.5	17	32	22	37	14	29	10	24.5
100	18.5	37	22.5	41	19.5	38	20	38.5	25	43.5	17	35.5	13	31

Applicable Cylinder Series: CDQ2K (Non-rotating rod)

(mm)

Auto switch model	D-A9□ D-A9□V		D-M9□ D-M9□V D-M9□W D-M9□WV D-M9□AL D-M9□AVL		D-A73 D-A80		D-A72/A7□H/A80H D-A73C/A80C/F7□ D-F79F/J79/F7□V D-J79C/F7□W D-J79W/F7□WV D-F7BAVL/F7BAL		D-F7NTL		D-A79W		D-P3DW□	
	A	B	A	B	A	B	A	B	A	B	A	B	A	B
Bore size														
12	7	3	11	7	9.5	5.5	10	6	15	11	7	3	—	—
16	10	2.5	14	6.5	12.5	5	13	5.5	18	10.5	10	2.5	—	—
20	13	3.5	17	7.5	15.5	6	16	6.5	21	11.5	13	3.5	—	—
25	13.5	4	17.5	8	16	6.5	16.5	7	21.5	12	13	4	—	—
32	17	5	21	9	18	6	18.5	6.5	23.5	11.5	15.5	3.5	11.5	0
40	12	7.5	16	11.5	13	8.5	13.5	9	18.5	14	10.5	6	6.5	2
50	10	10.5	14	14.5	11	11.5	11.5	12	16.5	17	8.5	9	4.5	4.5
63	12.5	13.5	16.5	17.5	13.5	14.5	14	15	19	20	11	12	7	7.5

Applicable Cylinder Series: CDQ2KW

(mm)

Auto switch model	D-A9□ D-A9□V		D-M9□ D-M9□V D-M9□W D-M9□WV D-M9□AL D-M9□AVL		D-A73 D-A80		D-A72/A7□H/A80H D-A73C/A80C/F7□ D-F79F/J79/F7□V D-J79C/F7□W D-J79W/F7□WV D-F7BAVL/F7BAL		D-F7NTL		D-A79W		D-P3DW□	
	A	B	A	B	A	B	A	B	A	B	A	B	A	B
Bore size														
12	7.5	7.5	11.5	11.5	9.5	10	10	10.5	15	15.5	7.5	7.5	—	—
16	10	8	14	12	12.5	10.5	13	11	18	16	10	8	—	—
20	13	10	17	14	15.5	12.5	16	13	21	18	13	10	—	—
25	13.5	10.5	17.5	14.5	16	13	16.5	13.5	21.5	18.5	13.5	10.5	—	—
32	17	12.5	21	16.5	18	13.5	18.5	14	23.5	19	15.5	11	11.5	7
40	12	18	16	22	13	19	13.5	19.5	18.5	24.5	10.5	16.5	6.5	12.5
50	10	20.5	14	24.5	11	21.5	11.5	22	16.5	27	8.5	19	4.5	14.5
63	12.5	19.5	16.5	23.5	13.5	20.5	14	21	19	26	11	18	7	13.5

Note) Adjust the auto switch after confirming the operating conditions in the actual setting.

Applicable Cylinder Series: CDQ2□S (Anti-lateral load)

(mm)

Auto switch model	D-A9□ D-A9□V		D-M9□ D-M9□V D-M9□W D-M9□WV D-M9□AL D-M9□AVL		D-A73 D-A80		D-A72/A7□H/A80H D-A73C/A80C/F7□ D-F79F/J79/F7□V D-J79C/F7□W D-J79W/F7□WV D-F7BAVL/F7BAL		D-F7NTL		D-A79W		D-P3DW□	
	A	B	A	B	A	B	A	B	A	B	A	B	A	B
Bore size														
32	14	9	18	13	15	10	15.5	10.5	20.5	15.5	12.5	7.5	8	3.5
40	17.5	12	21.5	16	18.5	13	19	13.5	24	18.5	16	10.5	11.5	6.5
50	15	15.5	19	19.5	16	16.5	16.5	17	21.5	22	13.5	14	9.5	9.5
63	17.5	18.5	21.5	22.5	18.5	19.5	19	20	24	25	16	17	12	12.5
80	20.5	23	24.5	27	21.5	24	22	24.5	27	29.5	19	21.5	15	17
100	23.5	29.5	27.5	33.5	24.5	30.5	25	31	30	36	22	28	18	23.5

Note) Adjust the auto switch after confirming the operating conditions in the actual setting.

Applicable Cylinder Series: CDQ2□R/□V (Water resistant)

(mm)

Auto switch model	D-M9□AL D-M9□AVL		D-F7BAL D-F7BAVL	
	A	B	A	B
Bore size				
20	19	7.5	18	6.5
25	19.5	8	18	7
32	22	9	19.5	6.5
40	16	11.5	13.5	9
50	14	14.5	11.5	12
63	16.5	17.5	14	15
80	19.5	22	17	19.5
100	24	27	21.5	24.5

Note) Adjust the auto switch after confirming the operating conditions in the actual setting.

Auto Switch Mounting Height

Applicable Cylinder Series: CDQ2, CDQ2W, CDQ2□□□□-□S/-□T (Single acting), CDQ2K, CDQ2KW (Non-rotating rod), CDQ2 (Long stroke), CDQ2□S (Anti-lateral load), CDQ2□R/□V (Water resistant)

(mm)

Auto switch model	D-M9□V	D-A9□V	D-F7□/J79 D-F7□W/J79W D-F7BAL D-F79F/F7NTL D-A7□H/A80H	D-F7□V D-F7□WV	D-J79C	D-A7□ D-A80	D-A73C D-A80C	D-A79W	D-P3DW□
	U	U	U	U	U	U	U	U	U
Bore size									
12	21.5	19	21.5	23.5	26.5	21	27.5	24.5	—
16	22.5	20	22.5	24.5	27.5	22	28.5	25.5	—
20	25	23	25.5	27.5	30	24.5	31	28	—
25	28	26	28	30.5	32.5	27.5	34	31	—
32	30	27.5	36	36.5	39.5	34	40.5	37.5	33
40	32	30	38	40	42.5	37.5	43.5	40.5	36.5
50	37.5	35	43.5	45	48	43	49	46	42
63	42.5	40.5	48.5	50.5	53.5	48	54.5	51.5	47
80	51	49	57	59	61.5	56.5	62.5	59.5	55.5
100	59	57	65.5	67	70	64.5	71	68	65.5

* The applicable auto switches for the CDQ2□R/□V (water resistant) are the D-M9□A(V)L type.

* The D-P3DW□ type is available from ø32 to ø100.

Applicable Cylinder Series: CDQ2, CDQ2W (Large bore size)

(mm)

Auto switch model	D-M9□V D-M9□WV D-M9□AVL	D-A9□V	D-A7□ D-A80	D-A7□H/A80H D-F7□/J79 D-F7□W/J79W D-F7BAL D-F79F/F7NTL	D-A73C D-A80C	D-F7□V D-F7□WV D-F7BAVL	D-J79C	D-A79W
	U	U	U	U	U	U	U	U
Bore size								
125	69.5	67.5	75.5	76.5	82.5	79	81	78
140	76.5	74.5	82.5	83.5	89.5	86	88	85
160	85.5	83.5	91.5	92.5	98.5	95	97	94
180	105.5	103.5	—	—	—	—	—	—
200	112.5	110.5	—	—	—	—	—	—

Standard

Large Bore Size

Long Stroke

Non-rotating Rod

Axial Piping

Anti-lateral Load

With End Lock

Water Resistant

With Auto Switch

Auto Switch

Made to Order

Compact Cylinder Series **CDQ2** With Auto Switch 3

2 Minimum Stroke for Auto Switch Mounting

Applicable Cylinder Series: CDQ2, CDQ2W, CDQ2□□□-□S/-□T (Single acting), CDQ2K, CDQ2KW (Non-rotating rod), CDQ2 (Long stroke), CDQ2□S (Anti-lateral load), CDQ2□R/□V (Water resistant) (mm)

Number of auto switches	D-M9□V D-F7□V D-J79C	D-A9□V D-A7□ D-A80 D-A73C D-A80C	D-A9□	D-M9□WV D-M9□AVL* D-F7□WV D-F7BAVL	D-M9□ D-M9□W D-M9□AL* D-A7□H D-A80H D-F7□ D-J79	D-A79W	D-F7□W D-J79W D-F7BAL D-F79F D-F7NTL	D-P3DW□
With 1 pc.	5	5	10	10	15	15	20	15
With 2 pcs.	5	10	10	15	15	20	20	15

* The applicable auto switches for the CDQ2□R/□V (water resistant) are the D-M9□A(V)L type.

Applicable Cylinder Series: CDQ2, CDQ2W (Large bore size) (mm)

Number of auto switches	D-M9□ D-M9□V D-F7□ D-F7□V D-J79 D-J79C	D-A9□ D-A9□V D-A7□ D-A80 D-A73C D-A80C D-A7□H D-A80H	D-M9□W D-M9□WV D-M9□AL D-M9□AVL	D-F7□W D-F7□WV D-J79W D-F7BAL D-F7BAVL D-F7NTL D-F79F	D-A79W
With 1 pc.	5	5	10	15	15
With 2 pcs.	5	10	15	20	20

3 Operating Range

Applicable Cylinder Series: CDQ2, CDQ2W, CDQ2□□□-□S/-□T (Single acting), CDQ2K, CDQ2KW (Non-rotating rod), CDQ2 (Long stroke), CDQ2□S (Anti-lateral load), CDQ2□R/□V (Water resistant) (mm)

Auto switch model	Bore size															
	12	16	20	25	32	40	50	63	80	100	125	140	160	180	200	
D-A9□(V)	7.5	9.5	10	9	9	9.5	9.5	11	10.5	10.5	13.5	12.5	12	13	12.5	
D-M9□(V) D-M9□W(V) D-M9□A(V)L*	3	5	5.5	5.5	5	5	6	6.5	7	7.5	7.5	8	7.5	7.5	8.5	
D-A7□(H)(C) D-A80□(H)(C)	9.5	12	12	11	10.5	11.5	11	13	11.5	11.5	16.5	15	14.5	—	—	
D-A79W	13	14.5	15.5	14	14	15.5	14.5	17	15	15.5	19.5	18	17.5	—	—	
D-F7□(V) D-J79(C) D-F7□W(V) D-F7BA(V)L D-F7NTL D-F79F	4.5	5.5	5	5	5	5	5	6	7	8	7.5	7.5	7.5	—	—	
D-P3DW□	—	—	—	—	3	4.5	4.5	6	5.5	6.5	—	—	—	—	—	

* Values which include hysteresis are for guideline purposes only, they are not a guarantee (assuming approximately ±30% dispersion) and may change substantially depending on the ambient environment.

* The applicable auto switches for the CDQ2□R/□V (water resistant) are the D-M9□A(V)L type.

4 Auto Switch Mounting Brackets/Part No.

Applicable Cylinder Series: CDQ2, CDQ2W, CDQ2□□□□-□S/-□T (Single acting), CDQ2, CDQ2W (Large bore size), CDQ2K, CDQ2KW (Non-rotating rod), CDQ2 (Long stroke), CDQ2□S (Anti-lateral load), CDQ2□R/□V (Water resistant)

Applicable auto switch	D-M9□/M9□V D-M9□W/M9□WV D-M9□AL/M9□AVL D-A9□/A9□V	D-F7□/F7□V/J79/J79C/F7□W/J79W/F7□WV D-F7BAL/F7BAVL/F79F/F7NTL D-A7□/A80/A7□H/A80H/A73C/A80C/A79W	D-P3DW□									
Bore size (mm)	ø12 to ø200	ø12 to ø25	ø32 to ø160									
Auto switch mounting bracket part no.	—	BQ4-012	BQ5-032									
Auto switch mounting bracket fitting parts lineup/Weight	—	<ol style="list-style-type: none"> ① Auto switch mounting screw (M2.5 x 8L) ② Auto switch mounting nut Weight: 1.5 g	<ol style="list-style-type: none"> ① Hexagon socket head cap screw (M2.5 x 6L) ② Hexagon socket head cap screw (M2.5 x 9L) ③ Auto switch mounting bracket (nut) Weight: 2.5 g									
When requesting the enclosure of the auto switch mounting brackets (2 pcs.) with the cylinder for shipment, add “-BQ” to the end of the cylinder model number. Standard model no. +BQ Example) CDQ2B32-30DZ-BQ/ CDQ2B32-30DZ-BQ-XC4 (Made to Order)												
Auto switch mounting surface	Surfaces with auto switch mounting slot	Auto switch mounting rail side only	A/B/C side except port side									
Mounting of auto switch	<p>Auto switch mounting screw</p> <p>Auto switch</p> <p>• When tightening the auto switch mounting screw, use a watchmakers' screwdriver with a handle 5 to 6 mm in diameter.</p> <p>Tightening torque for auto switch mounting screw (N·m)</p> <table border="1" style="width: 100%; border-collapse: collapse;"> <thead> <tr> <th>Auto switch model</th> <th>Tightening torque</th> </tr> </thead> <tbody> <tr> <td>D-M9□(V)</td> <td rowspan="2">0.05 to 0.15</td> </tr> <tr> <td>D-M9□W(V)</td> </tr> <tr> <td>D-M9□A(V)L</td> <td rowspan="2">0.10 to 0.20</td> </tr> <tr> <td>D-A9□(V)</td> </tr> </tbody> </table>	Auto switch model	Tightening torque	D-M9□(V)	0.05 to 0.15	D-M9□W(V)	D-M9□A(V)L	0.10 to 0.20	D-A9□(V)	<ol style="list-style-type: none"> ① Insert the nut into the auto switch mounting slot on the cylinder tube, and place it in the roughly estimated setting position. ② Engage the ridge on the auto switch mounting arm with the recess in the cylinder tube rail, and slide it to the position of the nut. ③ Gently screw the auto switch mounting screw into the thread of the auto switch mounting nut through the mounting hole on the auto switch mounting arm. ④ Confirm where the mounting position is, and tighten the auto switch mounting screw to fix the auto switch. The tightening torque of the M2.5 screw must be 0.25 to 0.35 N·m. ⑤ The detection position can be changed under the conditions in step ③. 	<ol style="list-style-type: none"> ① Insert the nut into the auto switch mounting slot on the cylinder tube, and place it in the roughly estimated setting position. ② With the lower tapered part of the auto switch spacer facing the outside of the cylinder tube, line up the M2.5 through hole with the M2.5 female thread of the auto switch mounting nut. ③ Gently screw the auto switch mounting nut fixing screw (M2.5) into the thread of the auto switch mounting nut through the mounting hole. ④ Engage the ridge on the auto switch mounting arm with the recess in the auto switch spacer. ⑤ Tighten the auto switch mounting screw (M3) to fix the auto switch. The tightening torque of the M3 screw must be 0.35 to 0.45 N·m. ⑥ Confirm where the mounting position is, and tighten the auto switch fixing screw (M2.5) to fix the auto switch mounting nut. The tightening torque of the M2.5 screw must be 0.25 to 0.35 N·m. ⑦ The detection position can be changed under the conditions in step ⑤. 	<ol style="list-style-type: none"> ① Insert the protrusion on the bottom of the auto switch into the mating part of the auto switch mounting bracket and fix the auto switch and the auto switch mounting bracket temporarily by tightening the hexagon socket head cap screw (M2.5 x 9L) 1 to 2 turns. ② Insert the temporarily tightened mounting bracket into the mating groove of the cylinder tube, and slide the auto switch onto the cylinder tube through the groove. ③ Check the detecting position of the auto switch and fix the auto switch firmly with the hexagon socket head cap screw (M2.5 x 6L, M2.5 x 9L).* ④ If the detecting position is changed, go back to step ②. <p>* The hexagon socket head cap screw (M2.5 x 6L) is used to fix the mounting bracket and cylinder tube. This enables the replacement of the auto switch without adjusting the auto switch position.</p> <p>Note 1) Ensure that the auto switch is covered with the mating groove to protect the auto switch.</p> <p>Note 2) The tightening torque of the hexagon socket head cap screw (M2.5 x 6L, M2.5 x 9L) must be 0.2 to 0.3 N·m.</p> <p>Note 3) Tighten the hexagon socket head cap screws evenly.</p>
	Auto switch model	Tightening torque										
D-M9□(V)	0.05 to 0.15											
D-M9□W(V)												
D-M9□A(V)L	0.10 to 0.20											
D-A9□(V)												

Note) Auto switch mounting bracket and auto switch are enclosed with the cylinder for shipment. For an environment that needs the water resistant auto switch, select the D-M9□A(V)L type. Auto switch mounting bracket for the D-F7BA(V)L type uses BQ4-012 and BQ5-032 normal specifications (metal screw).

* The auto switches applicable to the CDQ2□R/□V (water resistant) is the D-M9□A(V)L type.

Standard
 Large Bore Size
 Long Stroke
 Non-rotating Rod
 Axial Piping
 Anti-lateral Load
 With End Lock
 Water Resistant
 With Auto Switch
 Auto Switch
 Made to Order

Compact Cylinder Series **CDQ2** With Auto Switch 4

Other than the applicable auto switches listed in “How to Order”, the following auto switches are mountable. Refer to pages 1263 to 1371 in Best Pneumatics No. 2 for detailed specifications.

Applicable Cylinder Series: CDQ2, CDQ2W, CDQ2□□□□-□S/-□T (Single acting), CDQ2, CDQ2W (Large bore size), CDQ2K, CDQ2KW (Non-rotating rod), CDQ2 (Long stroke), CDQ2□S (Anti-lateral load)

Auto switch type	Model	Electrical entry	Features	Applicable bore size
Reed	D-A72	Grommet (Perpendicular)	—	ø12 to ø100 ø125 to ø160
	D-A73		—	
	D-A80		Without indicator light	
	D-A79W		Diagnostic indication (2-colour indication)	
	D-A73C	Connector (Perpendicular)	—	
	D-A80C		Without indicator light	
	D-A72H	Grommet (In-line)	—	
	D-A73H, A76H		—	
	D-A80H		Without indicator light	
Solid state	D-F7NV, F7PV, F7BV	Grommet (Perpendicular)	—	
	D-F7NWV, F7BWW		Diagnostic indication (2-colour indication)	
	D-F7BAVL		Water resistant (2-colour indication)	
	D-J79C	Connector (Perpendicular)	—	
	D-F79, F7P, J79	Grommet (In-line)	—	
	D-F79W, F7PW, J79W		Diagnostic indication (2-colour indication)	
	D-F7BAL		Water resistant (2-colour indication)	
	D-F79F		Diagnostic indication (2-colour indication)	
D-F7NTL	With timer			

* With pre-wired connector is also available for solid state auto switches. For details, refer to pages 1328 and 1329 in Best Pneumatics No. 2.

* Normally closed (NC = b contact) solid state auto switches (D-F9G/F9H) are also available. For details, refer to page 1290 in Best Pneumatics No. 2.

* Trimmer auto switch (D-F7K) and heat resistant solid state auto switch (D-F7NJL) are not available.

Prior to Use

Auto Switch Connection and Example

Basic Wiring

Solid state 3-wire, NPN

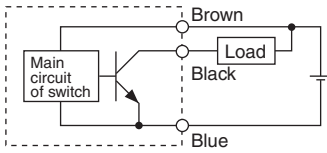

Solid state 3-wire, PNP

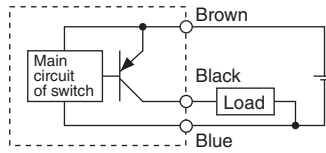

2-wire (Solid state)

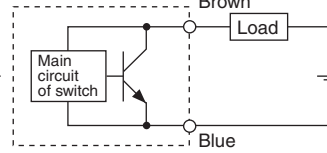

2-wire (Reed)

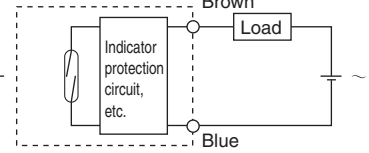

(Power supply for switch and load are separate.)

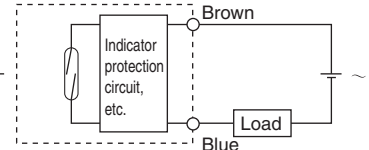
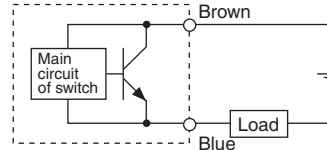
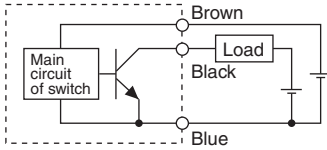

Example of Connection with PLC (Programmable Logic Controller)

• Sink input specifications 3-wire, NPN

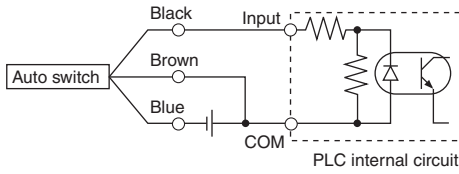

• Source input specifications 3-wire, PNP

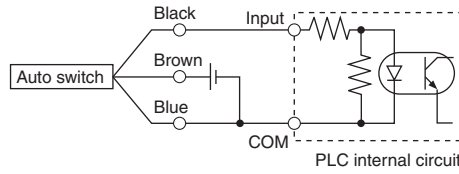

Connect according to the applicable PLC input specifications, as the connection method will vary depending on the PLC input specifications.

2-wire

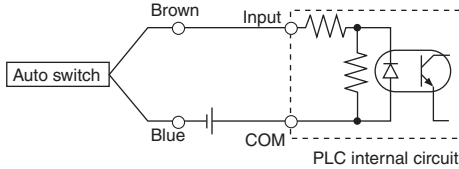

2-wire

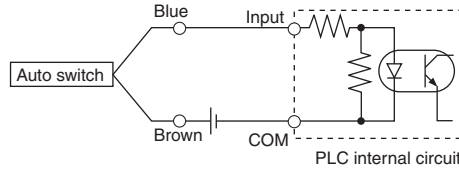

Example of AND (Series) and OR (Parallel) Connection

• 3-wire

AND connection for NPN output (Using relays)

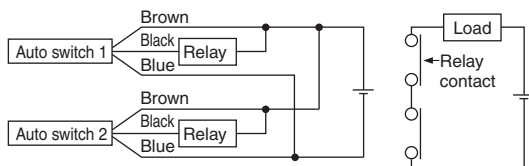

AND connection for NPN output (Performed with auto switches only)

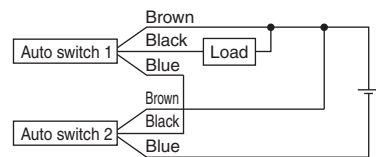

OR connection for NPN output

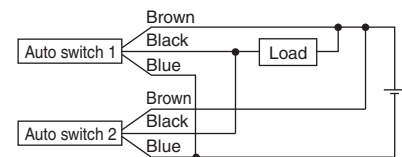

The indicator lights will light up when both of the auto switches are in the ON state.

• 2-wire

2-wire with 2-switch AND connection

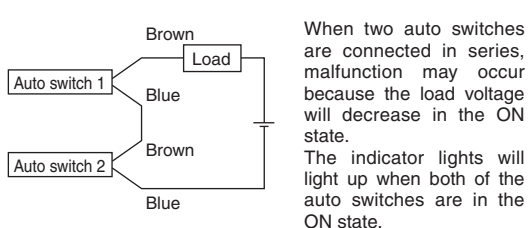

When two auto switches are connected in series, malfunction may occur because the load voltage will decrease in the ON state. The indicator lights will light up when both of the auto switches are in the ON state.

2-wire with 2-switch OR connection

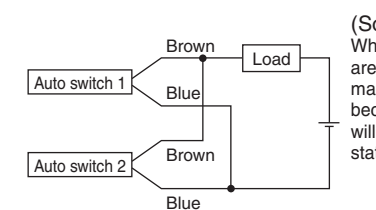

(Solid state)

When two auto switches are connected in parallel, malfunction may occur because the load voltage will increase in the OFF state.

(Reed)

Because there is no leakage current, the load voltage will not increase in the OFF state. However, depending on the number of auto switches in the ON state, the indicator lights may sometimes grow dim or not light up, due to the dispersion and reduction of the current flowing to the auto switches.

$$\begin{aligned} \text{Load voltage at ON} &= \text{Power supply voltage} - \text{Residual voltage} \times 2 \text{ pcs.} \\ &= 24 \text{ V} - 4 \text{ V} \times 2 \text{ pcs.} \\ &= 16 \text{ V} \end{aligned}$$

Example: Power supply voltage 24 VDC
Auto switch internal voltage drop 4 V

$$\begin{aligned} \text{Load voltage at OFF} &= \text{Leakage current} \times 2 \text{ pcs.} \times \text{Load impedance} \\ &= 1 \text{ mA} \times 2 \text{ pcs.} \times 3 \text{ k}\Omega \\ &= 6 \text{ V} \end{aligned}$$

Example: Load impedance 3 kΩ
Auto switch leakage current 1 mA

Series CQ2

Simple Specials/Made to Order



Please contact SMC for detailed specifications, lead times, and pricing.

Simple Specials

The following special specifications can be ordered as a simplified made-to-order. There is a specification sheet available on paper and CD-ROM. Please contact your SMC sales representatives if necessary.

Symbol	Specifications	CQ2 (Standard)				CQ2 (Large Bore Size)	
		Double acting		Single acting		Double acting	
		Single rod	Double rod	Single rod/ Spring return	Single rod/ Spring extend	Single rod	Double rod
-XA1 to 30	Special rod end shape	●	●	●			

Made to Order

Symbol	Specifications	CQ2 (Standard)				CQ2 (Large Bore Size)	
		Double acting		Single acting		Double acting	
		Single rod	Double rod	Single rod/ Spring return	Single rod/ Spring extend	Single rod	Double rod
-XB6	Heat resistant cylinder (-10 to 150°C)	●	●				
-XB7	Cold resistant cylinder (-40 to 70°C)	●	●				
-XB9	Low-speed cylinder (10 to 50 mm/s)	●	●				
-XB10	Intermediate stroke (Exclusive body type)	●	●	●		●	●
-XB10A	Intermediate stroke (Spacer-installed type) ^{Note 3)}	●					
-XB11	Long stroke (Air-hydro type only)	●					
-XB13	Low-speed cylinder (5 to 50 mm/s)	●	●				
-XB14	Cylinder with heat resistant auto switch ^{Note 2)}	●					
-XC4	With heavy-duty scraper	●	●				
-XC6	Piston rod/Retaining ring/Rod end nut material: Stainless steel	●	●	●	●		
-XC8	Adjustable stroke cylinder/Adjustable extension type	●					
-XC9	Adjustable stroke cylinder/Adjustable retraction type	●					
-XC10	Dual stroke cylinder/Double rod	●					
-XC11	Dual stroke cylinder/Single rod	●					
-XC26	With split pins for double clevis pin/double knuckle joint pin and flat washers	●		●	●		
-XC27	Double clevis pin/Double knuckle joint pin material: Stainless steel 304	●		●	●		
-XC35	With coil scraper	●	●				
-XC36	With boss on rod side	●	●	●	●		
-X144	Special port location	●	●	●	●		
-X202	Full length dimension is the same as Series CQ1.	●		●	●		
-X203	L dimension from rod cover is the same as Series CQ1.	●		●	●		
-X235	Special rod end for double rod cylinder		●				●
-X271	Fluororubber seals	●	●	●	●	●	●
-X293	Full length dimension is the same as Series CQ1W.		●				
-X525	Long stroke of adjustable extension stroke cylinder (-XC8)	●					
-X526	Long stroke of adjustable retraction stroke cylinder (-XC9)	●					
-X633	Intermediate stroke of double rod cylinder		●				●
-X636	Long stroke of dual stroke single rod cylinder	●					
-X1876	Cylinder tube: With concave boss on head side	●		●	●		

Simple Specials/Made to Order *Series CQ2*

CQ2 (Long Stroke) Double acting	CQ2K (Non-rotating Rod) Double acting		CQP2 (Axial Piping) <small>Note 2)</small>			CQ2□S (Anti-lateral Load) Double acting	CBQ2 (With End Lock) <small>Note 2)</small> Double acting	Page
Single rod	Single rod	Double rod	Double acting	Single acting		Single rod	Single rod	P.203
			Single rod	Single rod/ Spring return	Single rod/ Spring extend			

CQ2 (Long Stroke) Double acting	CQ2K (Non-rotating Rod) Double acting		CQP2 (Axial Piping)			CQ2□S (Anti-lateral Load) Double acting	CBQ2 (With End Lock) Double acting	Page
Single rod	Single rod	Double rod	Double acting	Single acting		Single rod	Single rod	P. 207
			Single rod	Single rod/ Spring return	Single rod/ Spring extend			P. 207
								P. 208
								P. 209
								P. 210
								P. 211
								P. 211
								P. 212
								P. 213
								P. 214
								P. 215
								P. 216
								P. 217
								P. 218
								P. 219
								P. 220
								P. 221
								P. 221
								P. 222
								P. 223
								P. 225
								P. 226
								P. 226
								P. 227
								P. 228
								P. 229
								P. 229
								P. 230
								P. 231

Standard

Large Bore Size

Long Stroke

Non-rotating Rod

Axial Piping

Anti-lateral Load

With End Lock

Water Resistant

With Auto Switch

Auto Switch

Made to Order

Note 1) For $\phi 40$ to $\phi 63$ only. $\phi 12$ to $\phi 32$ are available as a special product. Note 2) The body shape is the same as the existing product. Note 3) For $\phi 32$ to $\phi 100$ only.

Series CQ2 Simple Specials 1

These changes are dealt with Simple Specials System.

CQ2 (ø12 to ø25): Special Rod End Shape

Applicable Series

Series	Model	Action	Special rod end shape/Symbol
CQ2 (ø12 to ø25)	Standard	CQ2	Double acting, Single rod ^{Note)}
			Single acting (Spring return)
		CQ2W	Double acting, Double rod
	Non-rotating rod	CQ2K	Double acting, Single rod
		CQ2KW	Double acting, Double rod
	Axial piping (Centralised piping type)	CQP2	Double acting, Single rod ^{Note)}
			Single acting (Spring return/extend)
			XA1 XA2 XA6 XA7 XA11 XA17 XA18

Note) Except ø12, with rubber bumper (CQ2□12-DC, CQP2□12-DC)

Precautions

- SMC will make appropriate arrangements if no dimension, tolerance, or finish instructions are given in the diagram.
- Standard dimensions marked with "*" will be as follows to the rod diameter (D).
Enter any special dimension you desire.
ø12, ø16 → D - 1 mm ø20, ø25 → D - 2 mm
- In the case of double rod, fill in the dimension when the rod is retracted.
- It is not possible to manufacture when -XA17 and -XA18 are the same male thread diameter as the piston rod external diameter.
- Contact SMC separately for the special rod end shape/symbols other than the table on the left and the cases other than the manufacturing conditions.

<p>Symbol: A1</p>	<p>Symbol: A2</p>	<p>Symbol: A6</p>	<p>Symbol: A7 With chamfer</p>
<p>Symbol: A11</p>	<p>Symbol: A17</p>	<p>Symbol: A18</p>	

Symbol

-XA1/2/6/7/11/17/18

Conditions of Manufacture

Special rod end shape/Symbol	Single rod		Double rod
XA1	For $\phi 12$	ϕM : 3 mm or more 5 mm or less	ϕM : $\phi 5$ mm or less
	$\phi 16$	ϕM : 3 mm or more 7 mm or less	ϕM : $\phi 7$ mm or less
	$\phi 20$	ϕM : 4 mm or more 8 mm or less	ϕM : $\phi 8$ mm or less
	$\phi 25$	ϕM : 4 mm or more 10 mm or less	ϕM : $\phi 10$ mm or less
XA2	For $\phi 12$	ϕJ : 4 mm or more, W_1 : 6 mm or less	ϕJ : 3 mm or more, W_1 : 6 mm or less
	$\phi 16$	ϕJ : 4 mm or more, W_1 : 6 mm or less	ϕJ : 4 mm or more, W_1 : 6 mm or less
	$\phi 20$	ϕJ : 5 mm or more, W_1 : 11 mm or less	ϕJ : 5 mm or more, W_1 : 11 mm or less
	$\phi 25$	ϕJ : 6 mm or more, W_1 : 13 mm or less	ϕJ : 6 mm or more, W_1 : 13 mm or less
XA6	For $\phi 12$	H: M4 or less	H: M4 or less
	$\phi 16$	H: M6 or less	H: M6 or less
	$\phi 20$	H: M6 or less	H: M6 or less
	$\phi 25$	H: M8 or less	H: M8 or less
XA7	For $\phi 12$	H: M4 or less	H: M4 or less
	$\phi 16$	H: M5 or less	H: M5 or less
	$\phi 20$	H: M6 or less	H: M6 or less
	$\phi 25$	H: M8 or less	H: M8 or less
XA11	For $\phi 12$	SR3 mm only	SR3 mm or more
	$\phi 16$	SR4 mm only	SR4 mm or more
	$\phi 20$	SR5 mm only	SR5 mm or more
	$\phi 25$	SR6 mm only	SR6 mm or more
XA17	For $\phi 12$	H: M5 or more, X: 20 mm or less	H: M5 or less
	$\phi 16$	H: M6 or more, X: 22.5 mm or less	H: M6 or less
	$\phi 20$	H: M8 or more, X: 26.5 mm or less	H: M8 or less
	$\phi 25$	H: M10 or more, X: 33 mm or less	H: M10 or less
XA18	For $\phi 12$	H: M5 or more, X: 20 mm or less	H: M5 or less
	$\phi 16$	H: M6 or more, X: 22.5 mm or less	H: M6 or less
	$\phi 20$	H: M8 or more, X: 26.5 mm or less	H: M8 or less
	$\phi 25$	H: M10 or more, X: 33 mm or less	H: M10 or less

Standard

Large Bore Size

Long Stroke

Non-rotating Rod

Axial Piping

Anti-lateral Load

With End Lock

Water Resistant

With Auto Switch

Auto Switch

Made to Order

Series CQ2

Simple Specials 2

These changes are dealt with Simple Specials System.

CQ2 (ø32 to ø100): Special Rod End Shape

Applicable Series

Series		Action	Symbol for change of rod end shape	
CQ2	Standard type	CQ2	Double acting, Single rod Spring acting (Spring return)	
		CQ2W	Double acting, Double rod	
	Axial piping type (Centralized piping type)	CQP2	Double acting, Single rod Single acting (Spring return)	XA1 to 23 XA26 to 30
		CQ2□S	Double acting, Single rod	
	Long stroke	CQ2	Double acting, Single rod	
	Non-rotating rod type	CQ2K	Double acting, Single rod	XA1/XA2/XA6 XA10 to XA14 XA19/XA21
		CQ2KW	Double acting, Double rod (Non-rotating side)	XA1 to 23 XA26 to 30
			Double acting, Double rod (Round rod side)	

Series		Action	Symbol for change of rod end shape
CQ2	Large bore size ø125 to ø200	CQ2	Double acting, Single rod
		CQ2W	Double acting, Double rod

Precautions

- SMC will make appropriate arrangements if no dimension, tolerance, or finish instructions are given in the diagram.
- Standard dimensions marked with "*" will be as follows to the rod diameter (D).
Enter any special dimension you desire.
D – 2 mm
- In the case of double rod, fill in the dimension when the rod is retracted.

<p>Symbol: A1</p>	<p>Symbol: A2</p>	<p>Symbol: A3</p>	<p>Symbol: A4</p>
<p>Symbol: A5</p>	<p>Symbol: A6</p>	<p>Symbol: A7</p>	<p>Symbol: A8</p>
<p>Symbol: A9</p>	<p>Symbol: A10</p>	<p>Symbol: A11</p>	<p>Symbol: A12</p>

Symbol

-XA1 to XA23/-XA26 to XA30

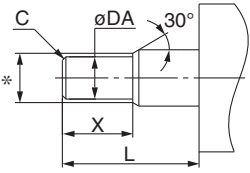
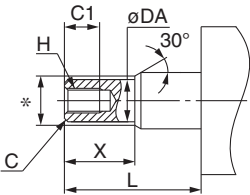
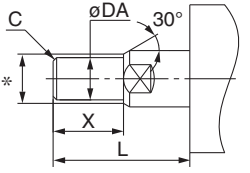
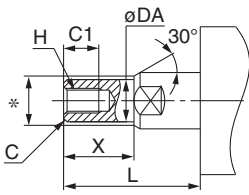
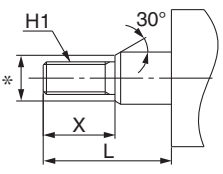
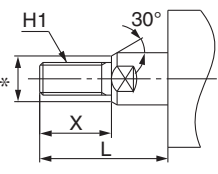
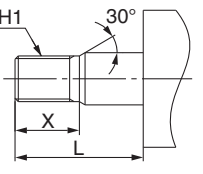
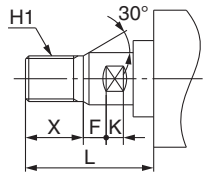
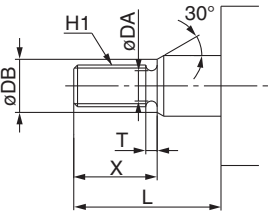
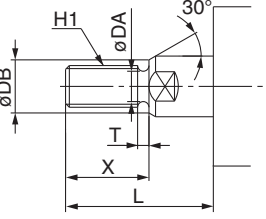
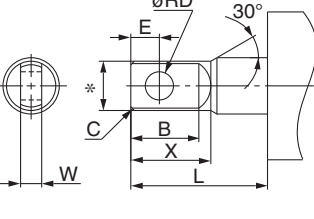
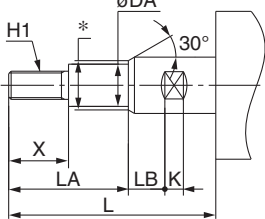
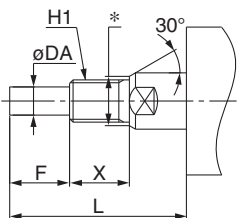
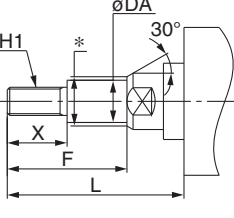
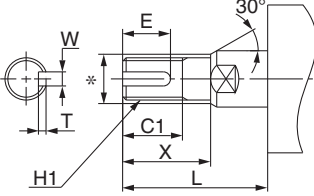
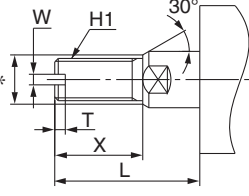
<p>Symbol: A13</p> 	<p>Symbol: A14</p> 	<p>Symbol: A15</p> 	<p>Symbol: A16</p> 
<p>Symbol: A17</p> 	<p>Symbol: A18</p> 	<p>Symbol: A19</p> 	<p>Symbol: A20</p> 
<p>Symbol: A21</p> 	<p>Symbol: A22</p> 	<p>Symbol: A23</p> 	<p>Symbol: A26</p> 
<p>Symbol: A27</p> 	<p>Symbol: A28</p> 	<p>Symbol: A29</p> 	<p>Symbol: A30</p> 

Standard
Large Bore Size
Long Stroke
Non-rotating Rod
Axial Piping
Anti-lateral Load
With End Lock
Water Resistant
With Auto Switch
Auto Switch
Made to Order

Series CQ2

Made to Order 1

Please contact SMC for detailed dimensions, specifications, and lead times.



Symbol

-XB6 Heat Resistant Cylinder (-10 to 150°C)

The seal material and grease for air cylinders have been changed for high temperature tolerance, now with a range of -10 to 150°C.

Applicable Series

Series	Model	Action	Note
CQ2	Standard	CQ2	Double acting, Single rod Except with rubber bumper
		CQ2W	
	Axial piping	CQP2	

How to Order

CQ2
CQ2W
CQP2

Standard model no. — XB6

Heat resistant cylinder

Specifications

Ambient temperature range	-10 to 150°C
Seal material	Fluororubber
Grease	Heat resistant grease
Specifications other than above and external dimensions	Same as standard



Note 1) Operate without lubrication from a pneumatic system lubricator.
Note 2) For maintenance intervals for this cylinder, which differ from those of the standard cylinder, please contact SMC.

Note 3) In principle, it is not possible to make built-in magnet type and mounted auto switch models. However, for cylinders with auto switches and heat resistant cylinders with heat resistant auto switches, please contact SMC as the compatibility differs depending on the series.

Note 4) Piston speed is ranged from 50 to 500 mm/s.

Note 5) For cylinders with rubber bumper, please contact SMC.

Warning Precautions

Be aware that smoking cigarettes, etc. after your hands have come into contact with the grease used in this cylinder can create a gas that is hazardous to humans.

Symbol

-XB7 Cold Resistant Cylinder (-40 to 70°C)

The seal material and grease for air cylinders have been changed for low temperature use, down to -40°C.

Applicable Series

Series	Model	Action	Note
CQ2	Standard	CQ2	Double acting, Single rod Except ø50 or more, with switch, with rubber bumper, with bracket
		CQ2W	
	Axial piping	CQP2	

How to Order

CQ2
CQ2W
CQP2

Standard model no. — XB7

Cold resistant cylinder

Specifications

Ambient temperature range	-40 to 70°C
Seal material	Low nitrile rubber
Grease	Cold resistant grease
Auto switch	Not mountable
External dimensions	Same as standard
Specifications other than above	Same as standard



Note 1) Operate without lubrication from a pneumatic system lubricator.
Note 2) Use dry air which is suitable for heatless air dryer, etc. not to cause the moisture to be frozen.

Note 3) For maintenance intervals for this cylinder, which differ from those of the standard cylinder, please contact SMC.

Note 4) Mounting an auto switch is not possible.

Note 5) For cylinders with rubber bumper, please contact SMC.

Warning Precautions

Be aware that smoking cigarettes, etc. after your hands have come into contact with the grease used in this cylinder can create a gas that is hazardous to humans.

Symbol

-XB9 Low-speed Cylinder (10 to 50 mm/s)

Even if driving at lower speeds 10 to 50 mm/s, there would be no stick-slip phenomenon and it can run smoothly.

Applicable Series

Series	Model	Action	Note
CQ2	Standard	CQ2	Double acting, Single rod
		CQ2W	Double acting, Double rod
	Axial piping	CQP2	Double acting, Single rod

How to Order

Q2
 Q2W Standard model no. - XB9
 QP2

Low-speed cylinder ●



Note) Operate without lubrication from a pneumatic system lubricator.

Warning Precautions

Be aware that smoking cigarettes, etc. after your hands have come into contact with the grease used in this cylinder can create a gas that is hazardous to humans.

Specifications

Piston speed	10 to 50 mm/s
External dimensions	Same as standard
Specifications other than above	Same as standard

Standard

Large Bore Size

Long Stroke

Non-rotating Rod

Axial Piping

Anti-lateral Load

With End Lock

Water Resistant

With Auto Switch

Auto Switch

Made to Order

Series CQ2

Made to Order 2

Please contact SMC for detailed dimensions, specifications, and lead times.



Symbol

-XB10 Intermediate Stroke (Exclusive body type)

Air cylinder which can reduce the mounting space by using an exclusive body which does not use a spacer to achieve that the full length dimension could be shortened when an intermediate stroke other than the standard stroke is required.

Applicable Series

Series	Model	Action	Note	
CQ2	Standard	CQ2	Double acting, Single rod	
		CQ2W	Single acting (Spring return)	
	Large bore size	CQ2W	Double acting, Double rod	
		CQ2	Double acting, Single rod	
	Long stroke	CQ2W	Double acting, Double rod	
		CQ2	Double acting, Single rod	
	Non-rotating rod	CQ2K	Double acting, Single rod	Except ø12 to ø32
		CQ2KW	Double acting, Double rod	
Anti-lateral load	CQ2□S	Double acting, Single rod		

How to Order

C□Q2
C□Q2W
C□Q2K
C□Q2KW
C□Q2□S



Specifications: Same as standard

Dimensions: Series CQ2

Double acting, Single rod

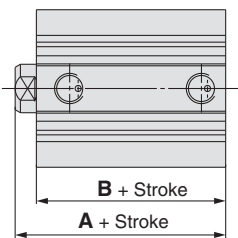

Double acting, Double rod

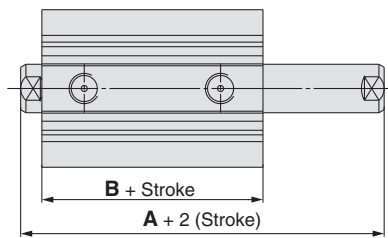

Double acting, Single rod/Long stroke

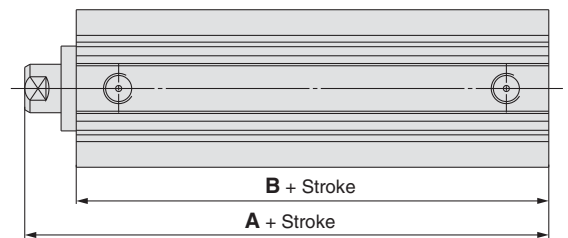

Bore size (mm)	Single rod				Applicable stroke range
	A		B		
	49 stroke or less	51 to 99 stroke	49 stroke or less	51 to 99 stroke	
12	20.5 (31.5)	—	17 (28)	—	6 to 29
16	22 (34)	—	18.5 (30.5)	—	
20	24 (36)	—	19.5 (31.5)	—	6 to 49
25	27.5 (37.5)	—	22.5 (32.5)	—	
32	30 (40)	40 (40)	23 (33)	33 (33)	6 to 99
40	36.5 (46.5)	46.5 (46.5)	29.5 (39.5)	39.5 (39.5)	
50	38.5 (48.5)	48.5 (48.5)	30.5 (40.5)	40.5 (40.5)	11 to 99
63	44 (54)	54 (54)	36 (46)	46 (46)	
80	53.5 (63.5)	63.5 (63.5)	43.5 (53.5)	53.5 (53.5)	
100	65 (75)	75 (75)	53 (63)	63 (63)	

(mm)

Bore size (mm)	Single rod (Long stroke)		Applicable stroke range
	A	B	
	32	62.5	
40	72	55	
50	73.5	55.5	
63	75	57	
80	86	66	
100	97.5	75.5	

(mm)

* The dimensions are the same with or without auto switch.



* (): Dimensions with auto switch
* The dimensions other than listed are the same as those of the standard.

Note) Applicable stroke: Available in 1 mm intervals

Bore size (mm)	Double rod				Applicable stroke range
	A		B		
	49 stroke or less	51 to 99 stroke	49 stroke or less	51 to 99 stroke	
12	32.2 (39.4)	—	25.2 (32.4)	—	6 to 29
16	33 (43)	—	26 (36)	—	
20	35 (47)	—	26 (38)	—	6 to 49
25	39 (49)	—	29 (39)	—	
32	44.5 (54.5)	54.5 (54.5)	30.5 (40.5)	40.5 (40.5)	6 to 99
40	54 (64)	64 (64)	40 (50)	50 (50)	
50	56.5 (66.5)	66.5 (66.5)	40.5 (50.5)	50.5 (50.5)	11 to 99
63	58 (68)	68 (68)	42 (52)	52 (52)	
80	71 (81)	81 (81)	51 (61)	61 (61)	
100	84.5 (94.5)	94.5 (94.5)	60.5 (70.5)	70.5 (70.5)	

(mm)

Bore size (mm)	Single rod (Single acting/Spring return)		Applicable stroke range
	A	B	
	12	20.5 (31.5)	
16	22 (34)	18.5 (30.5)	
20	24 (36)	19.5 (31.5)	6 to 9
25	27.5 (37.5)	22.5 (32.5)	
32	30 (40)	23 (33)	6 to 9
40	36.5 (46.5)	29.5 (39.5)	
50	38.5 (48.5)	30.5 (40.5)	

(mm)

Symbol
-XB10

Dimensions: Series CQ2

Double acting, Single rod/Large bore size

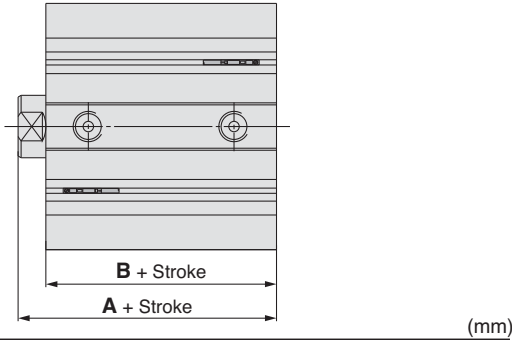

Bore size (mm)	Single rod		Applicable stroke range
	A	B	
125	99	83	11 to 299
140	99	83	
160	108	91	
180	119	102	
200	126	109	

* The dimensions other than listed are the same as those of the standard.
Note) Applicable stroke: Available in 1 mm intervals

Double acting, Double rod/Large bore size

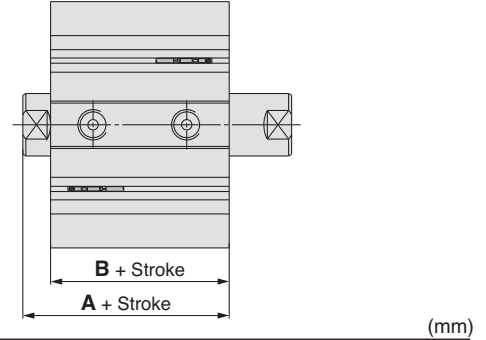

Bore size (mm)	Double rod		Applicable stroke range
	A	B	
125	115	83	11 to 299
140	115	83	
160	125	91	
180	136	102	
200	143	109	

* The dimensions other than listed are the same as those of the standard.
Note) Applicable stroke: Available in 1 mm intervals

Double acting, Single rod/End lock With head side locking

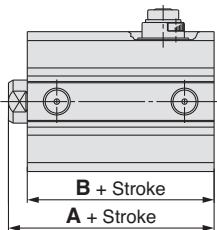

Head Side Locking (mm)

Bore size (mm)	A		B		Applicable stroke range(mm)
	24 stroke or less	26 to 99 stroke	24 stroke or less	26 to 99 stroke	
20	65.5	80.5	61	66	6 to 99
25	69	84	64	69	
32	72.5		65.5		
40	82		75		
50	83.5		75.5		
63	85		77		

Bore size (mm)	A		B		Applicable stroke range(mm)
	49 stroke or less	51 to 99 stroke	49 stroke or less	51 to 99 stroke	
80	121	136	111	116	6 to 99
100	132.5	147.5	120.5	125.5	

Double acting, Single rod/End lock With rod side locking

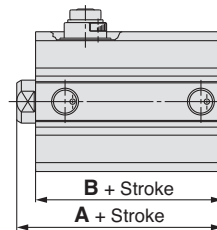

Rod Side Locking (mm)

Bore size (mm)	A		B		Applicable stroke range(mm)
	24 stroke or less	26 to 99 stroke	24 stroke or less	26 to 99 stroke	
20	59	80.5	54.5	66	6 to 99
25	62.5	84	57.5	69	
32	65		58		
40	71.5		64.5		
50	73.5		65.5		
63	79		71		

Bore size (mm)	A		B		Applicable stroke range(mm)
	49 stroke or less	51 to 99 stroke	49 stroke or less	51 to 99 stroke	
80	113.5	136	103.5	116	6 to 99
100	125	147.5	113	125.5	

Standard

Large Bore Size

Long Stroke

Non-rotating Rod

Axial Piping

Anti-lateral Load

With End Lock

Water Resistant

With Auto Switch

Auto Switch

Made to Order

Made to Order **Series CQ2**

Symbol

-XB10

Symbol

-XB10A Intermediate Stroke (Spacer-installed type)

Intermediate stroke: Available in 1 mm intervals

A spacer is installed on tubes with a stroke longer than the specified stroke (● in the below table).

Applicable Series

Series	Model	Action	Note
CQ2	Standard	CQ2	Double acting, Single rod
			ø32 to ø100

Applicable Stroke

Intermediate stroke with ◎: Available in 1 mm intervals

A spacer is installed on tubes with a stroke longer than the specified stroke (●).

◆: Standard stroke ●: Stroke in stock

Bore size (mm)	Stroke range	Type	Stroke																			
			55	60	65	70	*	75	80	85	90	95	*	100								
32, 40	51 to 94	Spacer-installed	◎	●	◎	●	◎	●	◎	●	—	◆	◎	●	◎	●	◎	●	◎	●	—	◆
50 to 100	51 to 94	type 2	◎	●	◎	●	◎	●	◎	●	—	◆	◎	●	◎	●	◎	●	◎	●	—	◆

Specifications: Same as standard

Note) Specify a spacer-installed type 1 with standard model number on page 3 for ordering intermediate stroke with a * mark.

How to Order

C□Q2 **Standard model no.** — **XB10 A**

Intermediate stroke ● Spacer-installed type ●

Order no.	CQ2B32-57DZ-XB10A (uses 60 mm stroke tube)
	• CQ2B32-60DZ-XB10 with 3 mm width spacer inside
	• The B dimension is 93 mm.

Dimensions: Series CQ2

Double acting,
Single rod

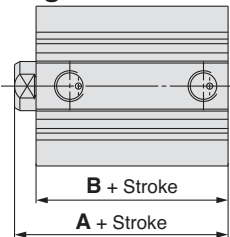

Symbol Stroke	A									B							
	51 to 54	56 to 59	61 to 64	66 to 69	76 to 79	81 to 84	86 to 89	91 to 94		51 to 54	56 to 59	61 to 64	66 to 69	76 to 79	81 to 84	86 to 89	91 to 94
Bore size																	
32	95	100	105	110	120	125	130	135		88	93	98	103	113	118	123	128
40	101.5	106.5	111.5	116.5	126.5	131.5	136.5	141.5		94.5	99.5	104.5	109.5	119.5	124.5	129.5	134.5
50	103.5	108.5	113.5	118.5	128.5	133.5	138.5	143.5		95.5	100.5	105.5	110.5	120.5	125.5	130.5	135.5
63	109	114	119	124	134	139	144	149		101	106	111	116	126	131	136	141
80	118.5	123.5	128.5	133.5	143.5	148.5	153.5	158.5		108.5	113.5	118.5	123.5	133.5	138.5	143.5	148.5
100	130	135	140	145	155	160	165	170		118	123	128	133	143	148	153	158

Series CQ2

Made to Order 3

Please contact SMC for detailed dimensions, specifications, and lead times.



Symbol

-XB11 Long Stroke (Air-hydro type only)

Strokes exceeding the standard stroke length

Applicable Series

Series	Model	Action	Note
CQ2	Air-hydro type (ø32 to ø100)	CQ2AH	Double acting, Single rod
			The external dimensions are the same as those of the CQ2 series long stroke type air cylinder.

How to Order

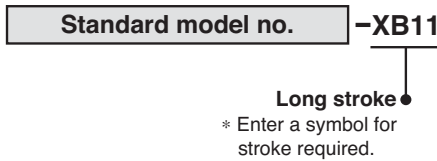

Specifications: Same as standard

Symbol

-XB13 Low-speed Cylinder (5 to 50 mm/s)

Even if driving at lower speeds 5 to 50 mm/s, there would be no stick-slip phenomenon and it can run smoothly.

Applicable Series

Series	Model	Action	Note
CQ2	Standard	CQ2	Double acting, Single rod
		CQ2W	Double acting, Double rod
	Axial piping	CQP2	Double acting, Single rod
			Except Large bore size, Long stroke, Non-rotating rod, Anti-lateral load, With end lock
			Except Large bore size, Non-rotating rod

How to Order



Note 1) Operate without lubrication from a pneumatic system lubricator.
Note 2) For speed control, use the low-speed-control speed controller (Series AS-FM/AS-M).

Specifications

Piston speed	5 to 50 mm/s
External dimensions	Same as standard
Specifications other than above	Same as standard

Warning Precautions

Be aware that smoking cigarettes, etc. after your hands have come into contact with the grease used in this cylinder can create a gas that is hazardous to humans.

Standard

Large Bore Size

Long Stroke

Non-rotating Rod

Axial Piping

Anti-lateral Load

With End Lock

Water Resistant

With Auto Switch

Auto Switch

Made to Order

Made to Order **Series CQ2**

Symbol

-XB14 Cylinder with Heat Resistant Auto Switch

Heat resistant compact cylinder CDQ2 series (ø16 to ø63), which can mount heat resistant solid state switch. (D-F7NJ½, Max. 150°C)

Applicable Series

Series	Model	Action	Note
CQ2	Standard	Double acting, Single rod	Applicable to ø16 to ø63 Except with rubber bumper Body shape: Same as the existing product

How to Order

CDQ2 Standard model no. — F7NJL — XB14

Note) The body shape is the same as the existing product.
"Z" is not included in the model number.

● Cylinder with heat resistant auto switch

Specifications

Applicable cylinder	Compact cylinder/Standard
Series	CQ2
Bore size (mm)	16, 20, 25, 32, 40, 50, 63
Type	Non-lube
Fluid	Air
Proof pressure	1.5 MPa
Maximum operating pressure	1.0 MPa
Minimum operating pressure	0.05 MPa (0.07 MPa: for ø16 only)
Ambient and fluid temperature	0 to 150°C
Rubber bumper	None
Rod end thread	Male or female thread
Stroke length tolerance	+1.0 0 mm
Piston speed	50 to 500 mm/s

Bore size (mm)	Standard stroke (mm)									
	15	20	25	30	35	40	45	50	70	100
16	●	●	●	●						
20	●	●	●	●	●	●	●	●		
25	●	●	●	●	●	●	●	●		
32	●	●	●	●	●	●	●	●	●	●
40	●	●	●	●	●	●	●	●	●	●
50	●	●	●	●	●	●	●	●	●	●
63	●	●	●	●	●	●	●	●	●	●

• Manufacture of intermediate strokes
Intermediate strokes in 1 mm intervals are available by installing a spacer in the standard stroke cylinder.

Note) Refer to page 1319 in Best Pneumatics No. 2 for further information on auto switches.

Auto Switch Proper Mounting Position (Detection at Stroke End)

ø16 to ø25

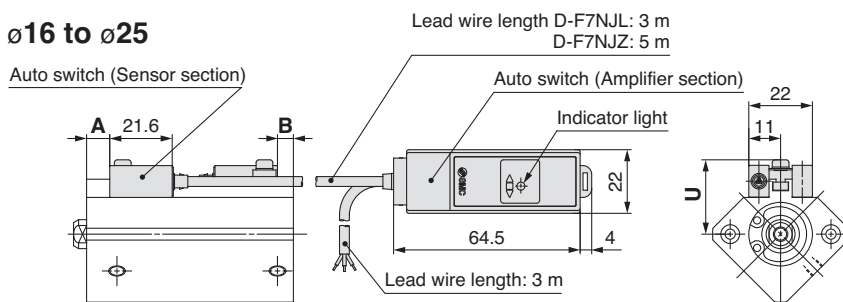

Bore size (mm)	(mm)		
	A	B	U
16	8	5.5	23.5
20	8	7	25.5
25	8	7.5	28.5
32	9.5	6.5	32.5
40	13.5	9	36
50	11.5	12	42
63	14	15	48.5

ø32 to ø63

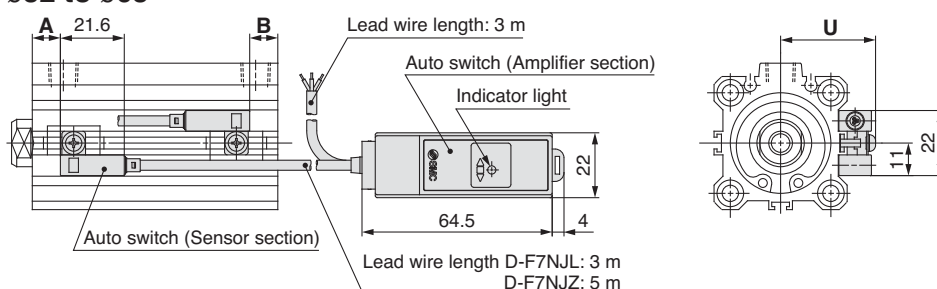

Auto Switch Mounting Bracket/Part No.

Auto switch model	Bore size (mm)					
	16	20	25	32	40	50
D-F7NJL(Z)	BQ-1			BQJ1-032		

Auto Switch Mounting Bracket/Weight

Mounting bracket part no.	Weight (g)
BQ-1	1.5
BQJ1-032	8.5

* The dimensions on the cylinder body is equivalent to the standard, double acting, single rod of the CDQ2 series.

Note 1) Auto switches are shipped in the same package, but not assembled in order to protect it at the time of shipment. Assemble it by referring to A, B dimensions for mounting position shown in the above table.

Note 2) The tightening torque of the auto switch mounting M3 screw must be 0.5 to 0.7 N·m.

Made to Order Common Specifications: -XC2(A): Rod End Length Extended 10 mm

14 Rod End Length Extended 10 mm

Symbol
-XC2(A)

Rod end length (L dimension) specifications of the cylinder for mounting the flange on the foot or rod side are "standard product + 10 mm" (-XC2).

Applicable Series

Series	Description	Model	Action	Note
CQ2	Standard type	CQ2	Double acting, Single rod	Foot style, Rod side flange only
		CQ2W	Double acting, Double rod	Foot style only
	Non-rotating rod type	CQ2K	Double acting, Single rod	Foot style, Rod side flange only
		CQ2KW	Double acting, Double rod	Foot style only

Rod end length (L dimension) specifications of the cylinder for mounting the double rod flange are "standard product + 10 mm" (-XC2A).

Applicable Series

Series	Description	Model	Action	Note
CQ2	Standard type	CQ2W	Double acting, Double rod	Flange only
	Non-rotating rod type	CQ2KW	Double acting, Double rod	Flange only

How to Order

Standard model no. **-XC2(A)**

- Rod end length extended 10 mm

-XC2	Foot style, Rod side flange only
-XC2A	For mounting double rod flange

Specifications: Same as standard type.

Dimensions (Dimensions other than below are the same as standard type.)

Double acting, Single rod

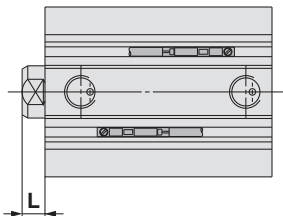

Rod end female thread

Double acting, Double rod (-XC2)

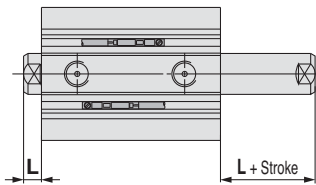

Rod end female thread

Double acting, Double rod (-XC2A)

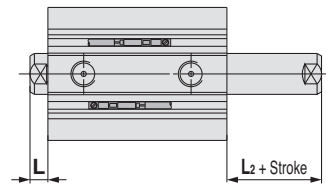

Rod end female thread

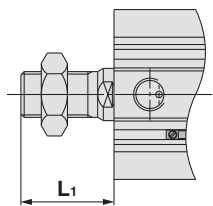

Rod end male thread

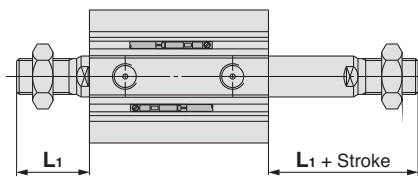

Rod end male thread

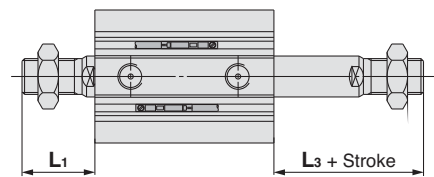

Rod end male thread

Dimensions (mm)

Bore size (mm)	Applicable Series		Dimensions	
	Standard type	Non-rotating rod type	Female thread	Male thread
			L	L1
12	○	—	13.5	24
16	○	—	13.5	25.5
20	○	—	14.5	28.5
25	○	—	15	32.5
32	○	—	17	38.5
40	○	○	17	38.5
50	○	○	18	43.5
63	○	○	18	43.5
80	○	—	20	53.5
100	○	—	22	53.5

Dimensions (mm)

Bore size (mm)	Applicable Series		Dimensions			
	Standard type	Non-rotating rod type	Female thread		Male thread	
			L	L2	L1	L3
12	⊕	—	13.5	3.5	24	14
16	⊕	—	13.5	3.5	25.5	15.5
20	⊕	—	14.5	4.5	28.5	18.5
25	⊕	—	15	5	32.5	22.5
32	⊕	—	17	7	38.5	28.5
40	⊕	⊕	17	7	38.5	28.5
50	⊕	⊕	18	8	43.5	33.5
63	⊕	⊕	18	8	43.5	33.5
80	⊕	—	20	10	53.5	43.5
100	⊕	—	22	12	53.5	43.5



Standard
Large Bore Size
Long Stroke
Non-rotating Rod
Axial Piping
Anti-lateral Load
With End Lock
Water Resistant
With Auto Switch
Auto Switch
Made to Order

Series CQ2

Made to Order 4

Please contact SMC for detailed dimensions, specifications, and lead times.



Symbol

-XC4 With Heavy-Duty Scraper

Suitable for using cylinders under the environment, where there are much dusts in a surrounding area by using a heavy-duty scraper on the wiper ring, or using cylinders under earth and sand exposed to the die-casted equipment, construction machinery, or industrial vehicles.

Applicable Series

Series	Model	Action	Note
CQ2	Standard	CQ2	Double acting, Single rod ø20 to ø100
		CQ2W	
	Long stroke	CQ2	Double acting, Single rod
	Axial piping	CQP2	Double acting, Single rod ø32 to ø100

How to Order

CQ2
 CQP2

Standard model no. — XC4

With heavy-duty scraper (SCB scraper)

Specifications: Same as standard

⚠ Caution

Do not replace heavy-duty scrapers.

- Since heavy-duty scrapers are press-fit, replace the entire rod cover assembly.

Series CQ2

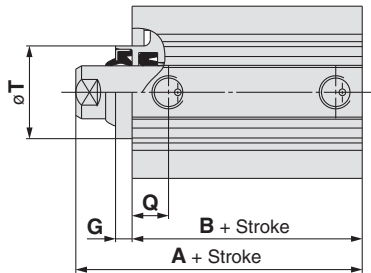

- (): Dimensions with auto switch
 - The other dimensions are the same as those of the standard, CQ2 series.
 - ø32, without switch, 5 mm stroke: Q-dimension is 21.5
 - Relation between ø12 to ø32 piping port and mounting holes is as the diagram on the right.
- For models with a bracket, please contact SMC.
Applicable stroke: Available in 5 mm intervals



Without switch: ø20 to ø32
With switch: ø32

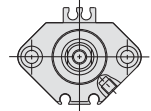

With switch: ø20, ø25

Series CQ2

Bore size (mm)	A			B			T	G		Q	
	50 stroke or less	75, 100 stroke	125 to 300 stroke	50 stroke or less	75, 100 stroke	125 to 300 stroke		100 stroke or less	125 stroke or more	50 stroke or less	125 stroke or more
20	34 (46)	—	—	29.5 (41.5)	—	—	—	—	—	19 (20.5)	—
25	37.5 (47.5)	—	—	32.5 (42.5)	—	—	—	—	—	21 (21)	—
32	40 (50)	50 (50)	67.5 (67.5)	33 (43)	43 (43)	55.5 (55.5)	—	—	—	20.5 (20.5)	—
40	46.5 (56.5)	56.5 (56.5)	77 (77)	29.5 (39.5)	39.5 (39.5)	55 (55)	28	5	10	11 (11)	14 (14)
50	48.5 (58.5)	58.5 (58.5)	78.5 (78.5)	30.5 (40.5)	40.5 (40.5)	55.5 (55.5)	35	5	10	10.5 (10.5)	14 (14)
63	54 (64)	64 (64)	80 (80)	36 (46)	46 (46)	57 (57)	35	5	10	15 (15)	16.5 (16.5)
80	63.5 (73.5)	73.5 (73.5)	91 (91)	43.5 (53.5)	53.5 (53.5)	66 (66)	43	5	10	16 (16)	19 (19)
100	75 (85)	85 (85)	102.5 (102.5)	53 (63)	63 (63)	75.5 (75.5)	59	5	10	23 (23)	23 (23)

Symbol

-XC6 Piston Rod/Retaining Ring/Rod End Nut Material: Stainless Steel

Suitable for the cases it is likely to generate rust by water immersion or corrosion.

Applicable Series

Series	Model	Action	Note	
CQ2	Standard	CQ2	Double acting, Single rod	
		CQ2W	Double acting, Double rod	
	Long stroke	CQ2	Double acting, Single rod	
	Axial piping	CQP2	Double acting, Single rod	
			Single acting (Spring return/extend)	
	Anti-lateral load	CQ2□S	Double acting, Single rod	

How to Order

- C□Q2
- C□Q2W
- C□QP2
- C□Q2□S

Standard model no. — XC6

Material: Stainless steel

Specifications

Parts changed to stainless steel	Piston rod, Rod end nut
Specifications other than above and external dimensions	Same as standard

Note) Retaining ring and piston rod are made of stainless steel. Rod end nut is also made of stainless steel for rod end male thread type.

Series CQ(P)2^R_V

Piston rod and rod end nut (male thread only) have been changed to stainless steel specification “-XC6”. Also, the materials for hexagon socket head cap screws to fix ø20 to ø32 rod covers have been changed to stainless steel.

Applicable Series

Series	Model	Action	Note
CQ2	Water resistant compact cylinder	C□Q2□ ^R _V	Double acting, Single rod
	Water resistant, axial piping	C□QP2□ ^R _V	Double acting, Single rod

How to Order

- C□Q2□^R_V
- C□QP2□^R_V

Standard model no. — XC6A

Steel parts: Stainless steel

Specifications

Parts changed to stainless steel	Piston rod, Rod end nut (male thread only), Rod cover holding hexagon socket head cap screw
Specifications other than above and external dimensions	Same as standard

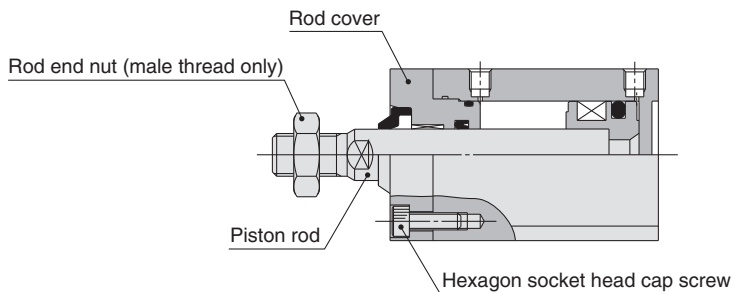

Standard

Large Bore Size

Long Stroke

Non-rotating Rod

Axial Piping

Anti-lateral Load

With End Lock

Water Resistant

With Auto Switch

Auto Switch

Made to Order

Series CQ2

Made to Order 5

Please contact SMC for detailed dimensions, specifications, and lead times.



Symbol

-XC8 Adjustable Stroke Cylinder/Adjustable Extension Type

The extending stroke by the cylinder can be adjusted by the stroke adjustment mechanism equipped on the head end.

Applicable Series

	Series	Model	Action	Note
CQ2	Standard	CQ2	Double acting	Except with rubber bumper and with bracket
	Non-rotating rod	CQ2K	Double acting	Except with rubber bumper and with bracket
	Air-hydro type	CQ2H	Double acting	Except with mounting bracket

How to Order

C□Q2B(H)
C□Q2K

Bore size — **Stroke** D(M)(Z) — **XC8**

Adjustable stroke cylinder/Adjustable extension type

Specifications

Series	Stroke adjustment range (mm)
CQ2	0 to 10

Note) The specifications other than above are the same as those of the standard.

Precautions

Warning

- When the cylinder is operating, if something gets caught between the stopper bracket for adjusting the stroke and the cylinder body, it could cause bodily injury or damage the peripheral equipment. Therefore, take preventive measures as necessary, such as installing a protective cover.
- To adjust the stroke, make sure to secure the wrench flats of the stopper bracket by a wrench, etc. before loosening the lock nut. If the lock nut is loosened without securing the stopper bracket, be aware that the area that joins the load to the piston rod or the area in which the piston rod is joined with the load side and the stopper bracket side could loosen first. It may cause an accident or malfunction.

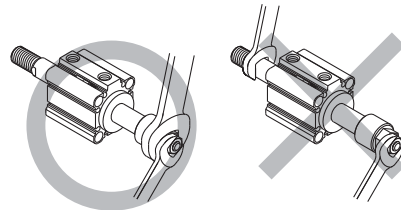

Symbol

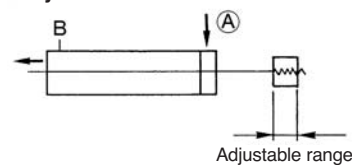

Series CQ2, CQ2H

ø12 to ø25

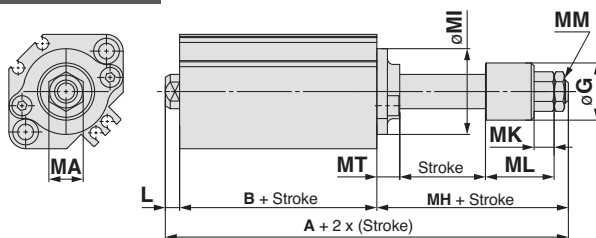

ø32 to ø100

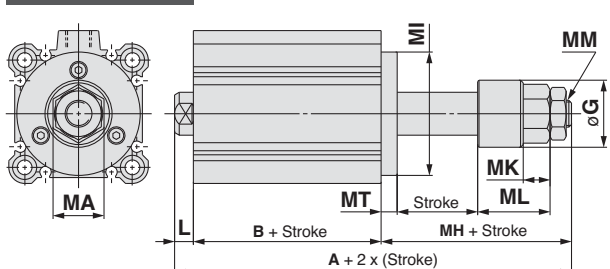

Bore size	(mm)													Stroke adjustment range
	A	B	L	MH	MT	MA	MI	MM	MK	ML	øG			
12	57.7 (64.9)	25.2 (32.4)	3.5	29	5	8	□25 (ø15)	M4 x 0.7	5.5	20	14		5 to 30	
16	58.5 (68.5)	26 (36)	3.5	29	5	10	□28 (ø20)	M5 x 0.8	5.5	20	14			
20	67.5 (79.5)	26 (38)	4.5	37	8	12	□36 (ø25)	M6 x 1	7	24	20		5 to 50	
25	71 (81)	29 (39)	5	37	8	12	□40 (ø30)	M6 x 1	7	24	20			
32	78.5 (88.5)	30.5 (40.5)	7	41	6	17	ø38	M8 x 1.25	9	28.5	25		5 to 50	
	88.5	40.5										75,100		
40	88 (98)	40 (50)	7	41	6	19	ø46	M10 x 1.25	10	27	25		5 to 50	
	98	50										75,100		
50	100.5 (110.5)	40.5 (50.5)	8	52	8	24	ø57	M14 x 1.5	13	31	35		10 to 50	
	110.5	50.5										75,100		
63	102 (112)	42 (52)	8	52	10	24	ø68	M14 x 1.5	13	31	35		10 to 50	
	112	52										75,100		
80	125 (135)	51 (61)	10	64	12	32	ø90	M20 x 1.5	16	40	45		10 to 50	
	135	61										75,100		
100	138.5 (148.5)	60.5 (70.5)	12	66	14	32	ø110	M20 x 1.5	16	40	45		10 to 50	
	148.5	70.5										75,100		

Note 1) (): Denotes the dimensions with auto switch.
Note 2) Applicable stroke available by the 5 mm interval.

Symbol

-XC9 Adjustable Stroke Cylinder/Adjustable Retraction Type

The retracting stroke of the cylinder can be adjusted by the adjusting bolt.

Applicable Series

Series	Model	Action	Note
CQ2	Standard	Double acting, Single rod	Except with rubber bumper and with bracket
	Non-rotating rod		

How to Order

C□Q2B **Bore size** – **Stroke** D(M)(Z) – XC9
 Adjustable stroke cylinder/Adjustable retraction type

Specifications

Series	Stroke adjustment range (mm)
CQ2	0 to 10

Note) The specifications other than above are the same as those of the standard.

Precautions

Warning

- When air is supplied to the cylinder, if the stroke adjusting bolt is loosened in excess of the allowable stroke adjustment amount, be aware that the stroke adjusting bolt could fly out or air could be discharged, which could cause bodily injury or damage the peripheral equipment.
- Adjust the stroke when the cylinder is not pressurized. If it is adjusted in the pressurized state, the seal of the adjustment section could become deformed, leading to air leakage.

Symbol

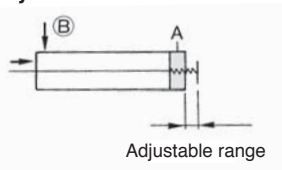

Series CQ2

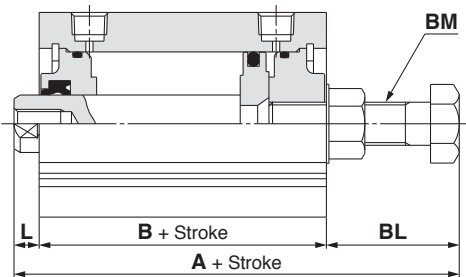

∅20, ∅25, ∅32

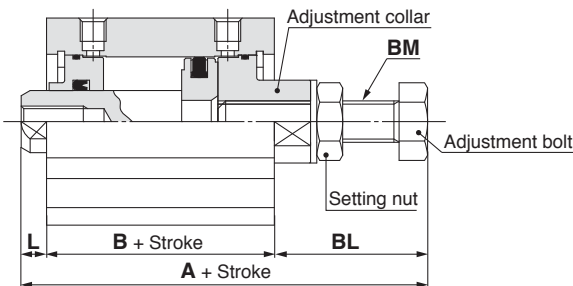

Bore size (mm)	A	B	L	BL	BM	Stroke range (mm)
12	52 (59.2)	25.2 (32.4)	3.5	23.3	M5 x 0.8	5 to 30
16	53 (63)	26 (36)	3.5	23.5	M6 x 1	
20	61 (73)	26 (38)	4.5	30.5	M8 x 1.25	5 to 50
25	63.5 (73.5)	29 (39)	5	29.5	M8 x 1.25	
32	65.5 (75.5)	30.5 (40.5)	7	28	M8 x 1.25	5 to 50
40	84 (94)	40 (50)	7	37	M12 x 1.5	75, 100
50	84.5 (94.5)	40.5 (50.5)	8	36	M12 x 1.5	
63	88.5 (98.5)	42 (52)	8	38.5	M16 x 1.5	10 to 50
80	109.5 (119.5)	51 (61)	10	48.5	M20 x 1.5	75, 100
100	125 (135)	60.5 (70.5)	12	52.5	M24 x 1.5	

Note 1) (): Dimensions with auto switch

Note 2) Applicable stroke: Available in 5 mm intervals

Standard

Large Bore Size

Long Stroke

Non-rotating Rod

Axial Piping

Anti-lateral Load

With End Lock

Water Resistant

With Auto Switch

Auto Switch

Made to Order

Series CQ2

Made to Order 6

Please contact SMC for detailed dimensions, specifications, and lead times.



Symbol

-XC10 Dual Stroke Cylinder/Double Rod

Two cylinders are constructed as one cylinder in a back-to-back configuration allowing the cylinder stroke to be controlled in three steps.

Applicable Series

Series	Model	Action	Note
CQ2	Standard	CQ2	Double acting, Single rod Except with bracket
	Non-rotating rod	CQ2K	
	Air-hydro type	CQ2H	

How to Order

Q2B Q2K **Bore size** - **Stroke S₁** + **Stroke S₂** **D(C)(M)(Z) - XC10**
 Dual stroke cylinder

Specifications

Series	Bore size (mm)	Max. manufacturable stroke (mm)
CQ2	12, 16	60 (Max. on single side: 30)
	20, 25	100 (Max. on single side: 50)
	32, 40	200 (Max. on single side: 100)
	50 to 100	200 (Max. on single side: 100)

Note) The specifications other than above are the same as those of the standard.

Dimensions (Other dimensions are the same as those of the standard.)

Series CQ2

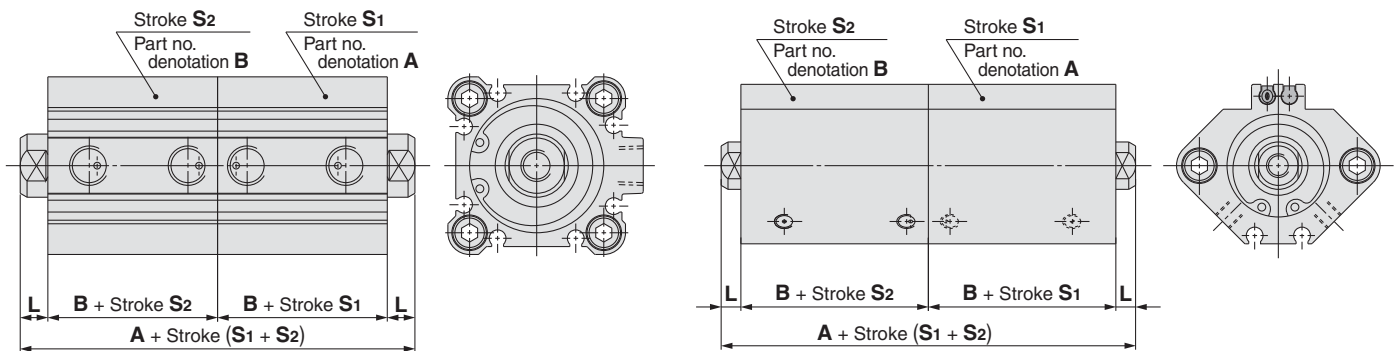

Note) In the case of $\phi 12$ to $\phi 25$ with auto switch, port directions are different.

Bore size	A		B		L	Stroke Both of S ₁ , S ₂
	50 st or less	75, 100 st	50 st or less	75, 100 st		
12	41 (63)	—	17 (28)	—	3.5	5 to 30
16	44 (68)	—	18.5 (30.5)	—	3.5	
20	48 (72)	—	19.5 (31.5)	—	4.5	5 to 50
25	55 (75)	—	22.5 (32.5)	—	5	
32	60 (80)	80 (80)	23 (33)	33 (33)	7	5 to 100
40	73 (93)	93 (93)	29.5 (39.5)	39.5 (39.5)	7	
50	77 (97)	97 (97)	30.5 (40.5)	40.5 (40.5)	8	10 to 100
63	88 (108)	108 (108)	36 (46)	46 (46)	8	
80	107 (127)	127 (127)	43.5 (53.5)	53.5 (53.5)	10	
100	130 (150)	150 (150)	53 (63)	63 (63)	12	

Note 1) (): Dimensions with auto switch

Note 2) Applicable stroke: Available in 5 mm intervals

Symbol

-XC11 Dual Stroke Cylinder/Single Rod

Two cylinders can be integrated by connecting them in line, and the cylinder stroke can be controlled in two stages in both directions.

Applicable Series

Series	Model	Action	Note
CQ2	Standard	Double acting, Single rod	Except with bracket
	Air-hydro type		

How to Order

C□Q2B **Bore size** - **Stroke S₁** + **Stroke S₂ - S₁** D(C)(M)(Z) - **XC11**
 Dual stroke cylinder/Single rod

Specifications: Same as standard

(For manufacturable strokes, please contact SMC.)

Construction/Dimensions

Series CQ2

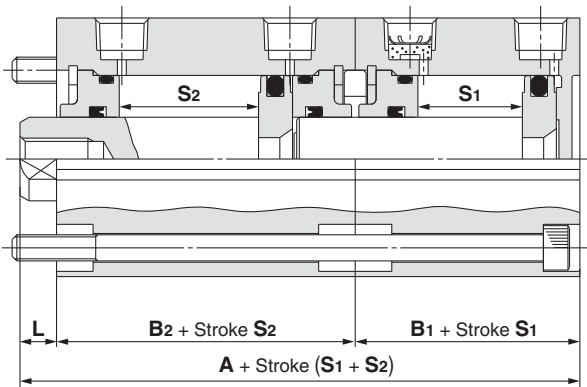

Bore size (mm)	A	B ₁	B ₂	L	Stroke Both of S ₁ , S ₂
12	45.7 (63.9)	17 (28)	25.2 (32.4)	3.5	5 to 30
16	48 (70)	18.5 (30.5)	26 (36)	3.5	
20	50 (74)	19.5 (31.5)	26 (38)	4.5	
25	56.5 (76.5)	22.5 (32.5)	29 (39)	5	5 to 50
32	60.5 (80.5)	23 (33)	30.5 (40.5)	7	
40	76.5 (96.5)	29.5 (39.5)	40 (50)	7	
50	79 (99)	30.5 (40.5)	40.5 (50.5)	8	10 to 50
63	86 (106)	36 (46)	42 (52)	8	
80	104.5 (124.5)	43.5 (53.5)	51 (61)	10	
100	125.5 (145.5)	53 (63)	60.5 (70.5)	12	

Note 1) (): Dimensions with auto switch
 Note 2) Applicable stroke: Available in 5 mm intervals
 Note 3) For long stroke type, please contact SMC.

- Standard
- Large Bore Size
- Long Stroke
- Non-rotating Rod
- Axial Piping
- Anti-lateral Load
- With End Lock
- Water Resistant
- With Auto Switch
- Auto Switch
- Made to Order

Series CQ2

Made to Order 7

Please contact SMC for detailed dimensions, specifications, and lead times.



Symbol

-XC26 With Split Pins for Double Clevis Pin/Double Knuckle Joint Pin and Flat Washers

A pin for double clevis (one of the mounting types) or double knuckle joint (one of the accessories) has been changed for a split pin, and split pins and flat washers have been added.

Applicable Series

Series	Model	Action	
CQ2	Standard	Double acting, Single rod	
		Single acting (Spring return/extend)	
	Long stroke	CQ2□	Double acting, Single rod
	Non-rotating rod	CQ2K	Double acting, Single rod
	Anti-lateral load	CQ2□S	Double acting, Single rod
	With end lock	CBQ2	Double acting, Single rod
	Magnetic field resistant	CDQ2□P	Double acting, Single rod
	Copper-free compact	20-CQ2	Double acting, Single rod
			Single acting (Spring return/extend)
	Copper-free long stroke	20-CQ2□	Double acting, Single rod
Copper-free anti-lateral load	20-CQ2□S	Double acting, Single rod	

Specifications

Mounting	Double clevis (D) only
Changed parts	Clevis pin/Knuckle pin, Split pin, Flat washer
Specifications other than above	Same as standard

Dimensions

Double clevis

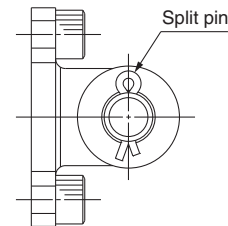
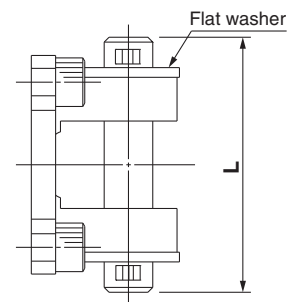

Bore size (mm)	L (mm)
12	21
16	23
20	31
25	36.5
32	52.5
40	52.5
50	66
63	66
80	78
100	86

* For mounting bracket, split pins, clevis pin and flat washers are shipped together, (but not assembled).

* Mounting method is the same as standard.

Double knuckle joint

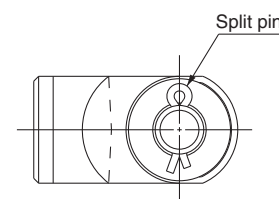
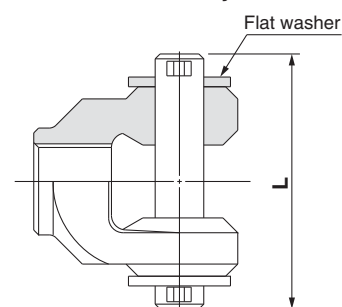

* For mounting bracket, split pins, knuckle pin and flat washers are shipped together, (but not assembled).

* Mounting method is the same as standard.

How to Order

● Product

CQ2D Standard model no. - XC26

● Double clevis

With double clevis pin, split pins and flat washers

● Parts assembly

CQ - D 032 - XC26

● Double clevis

● Double clevis pin

Bore size

012	12 mm
016	16 mm
020	20 mm
025	25 mm
032	32 mm
040	40 mm
050	50 mm
063	63 mm
080	80 mm
100	100 mm

Y - G012, Z015A, G02, G03
G04, G05, G08, G10 - XC26

● Double knuckle joint

With double knuckle joint pin,
split pins and flat washers

IY - G012, J015, G02
G03, G04, G05, G08, G10 - XC26

● Clevis pin/Knuckle pin

With clevis pin/knuckle pin,
split pins and flat washers

Symbol

-XC27 Double Clevis Pin/Double Knuckle Joint Pin Material: Stainless Steel 304

For preventing the oscillating portion of the double clevis or the double knuckle joint from rusting, the material of the pin and the retaining ring has been changed to stainless steel.

Applicable Series

Series	Model	Action	
CQ2	Standard	CQ2	
			Double acting, Single rod
			Single acting (Spring return/extend)
	Long stroke	CQ2□	Double acting, Single rod
	Non-rotating rod	CQ2K	Double acting, Single rod
	Anti-lateral load	CQ2□S	Double acting, Single rod
	Magnetic field resistant	CDQ2□P	Double acting, Single rod
	Copper-free compact	20-CQ2	Double acting, Single rod
			Single acting (Spring return/extend)
Copper-free long stroke	20-CQ2□	Double acting, Single rod	
Copper-free anti-lateral load	20-CQ2□S	Double acting, Single rod	

Specifications

Mounting	Double clevis (D) only
Pin material	Stainless steel 304
Specifications other than above	Same as standard

How to Order

● **Product**

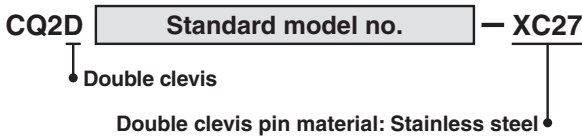

● **Parts assembly**

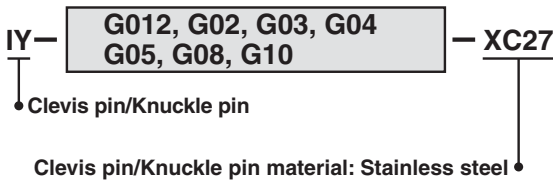
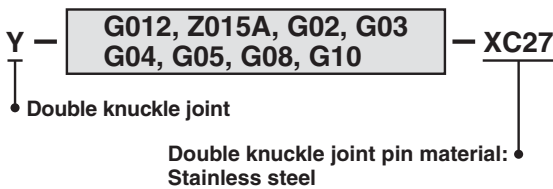
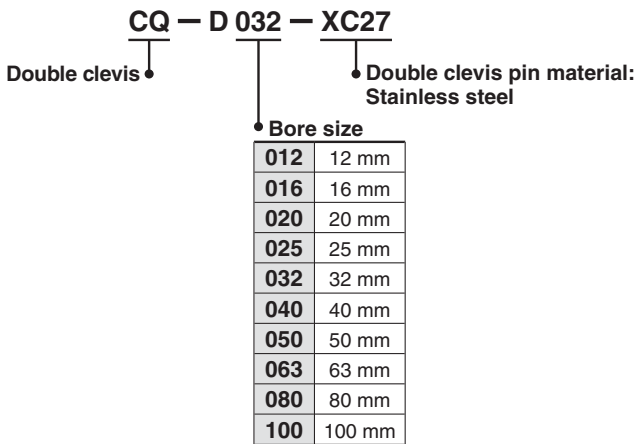

* Stainless steel specification for IY-J015 is IY-J015SUS.

Standard

Large Bore Size

Long Stroke

Non-rotating Rod

Axial Piping

Anti-lateral Load

With End Lock

Water Resistant

With Auto Switch

Auto Switch

Made to Order

Series CQ2

Made to Order 8

Please contact SMC for detailed dimensions, specifications, and lead times.



Symbol

-XC35 With Coil Scraper

For getting rid of frost, ice, weld spatter, cutting chips adhered to the piston rod, and for protecting the seals, etc.

Applicable Series

Series	Model	Action	Note
CQ2	Standard	CQ2	Applicable to $\phi 32$ to $\phi 100$, Except with bracket
		CQ2W	
	Axial piping	CQP2	

How to Order

Standard model no. — XC35

With coil scraper ●

Specifications: Same as standard

Series CQ2

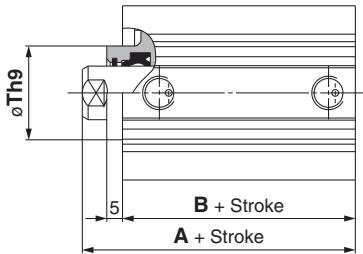

Bore size (mm)	A		B		Th9
	50 stroke or less	51 to 100 stroke	50 stroke or less	51 to 100 stroke	
32	35 (45)	45 (45)	23 (33)	33 (33)	23 ⁰ _{-0.052}
40	41.5 (51.5)	51.5 (51.5)	29.5 (39.5)	39.5 (39.5)	28 ⁰ _{-0.052}
50	43.5 (53.5)	53.5 (53.5)	30.5 (40.5)	40.5 (40.5)	35 ⁰ _{-0.062}
63	49 (59)	59 (59)	36 (46)	46 (46)	35 ⁰ _{-0.062}
80	58.5 (68.5)	68.5 (68.5)	43.5 (53.5)	53.5 (53.5)	43 ⁰ _{-0.062}
100	70 (80)	80 (80)	53 (63)	63 (63)	59 ⁰ _{-0.074}

Note 1) (): Dimensions with auto switch

Note 2) Applicable stroke: Available in 5 mm intervals

Symbol

-XC36 With Boss on Rod side

Cylinder with boss on rod side

Applicable Series

Series	Model	Action	
CQ2	Standard	CQ2	
		CQ2W	
	Axial piping	CQP2	CQ2
			CQ2W

Note 1) For double rod type, it comes with boss on both sides.

Note 2) Except with bracket

Note 3) Except $\phi 125$ or more

How to Order

Standard model no. — XC36

With boss on rod side ●

Specifications: Same as standard

Dimensions

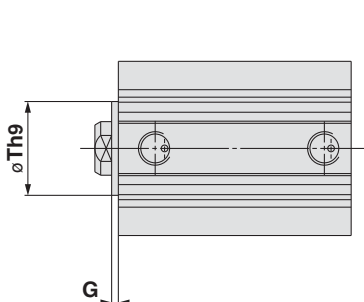

* The dimensions except mentioned above are the same as those of the standard.

Series	CQ2	
	Th9	G
Bore size (mm)		
12	15 ⁰ _{-0.043}	1.5
16	20 ⁰ _{-0.052}	1.5
20	13 ⁰ _{-0.043}	2
25	15 ⁰ _{-0.043}	2
32	21 ⁰ _{-0.052}	2
40	28 ⁰ _{-0.052}	2
50	35 ⁰ _{-0.062}	2
63	35 ⁰ _{-0.062}	2
80	43 ⁰ _{-0.062}	2
100	59 ⁰ _{-0.074}	2

Made to Order Common Specifications: -XC85: Grease for Food Processing Equipment

Symbol
-XC85

57 Grease for Food Processing Equipment

Food grade grease (certified by NSF-H1) is used as lubricant.

Applicable Series

Series	Description	Model	Action
CQ2	Compact cylinder	CQ2	Double acting, Single rod
		CQ2	Single acting, Single rod
		CQ2W	Double acting, Double rod
	Long stroke	CQ2	Double acting, Single rod
		CQ2B	Double acting, Single rod
	Large bore size	CQ2WB	Double acting, Double rod
		CQ2□S	Double acting, Single rod
	Anti-lateral load	CQP2	Double acting, Single rod
	Axial piping type (Centralized piping type)	CQP2	Single acting, Single rod
		CBQ2	Double acting, Single rod

How to Order

Standard model no. **-XC85**

Grease for food processing equipment

Specifications

Ambient temperature range	-1°C to 70°C
Seal material	Nitrile rubber
Grease	Grease for food
Auto switch	Mountable
Dimensions	Same as standard model
Specifications other than above	Same as standard model

Warning Precautions

Be aware that smoking cigarettes, etc. after your hands have come into contact with the grease used in this cylinder can create a gas that is hazardous to humans.

<Not installable>

Food zone.....An environment where food which will be sold as merchandize, directly touches the cylinder's components.

Splash zone.....An environment where food which will not be sold as merchandize, directly touches the cylinder's components.

<Installable>

Non-food zone.....An environment where there is no contact with food.

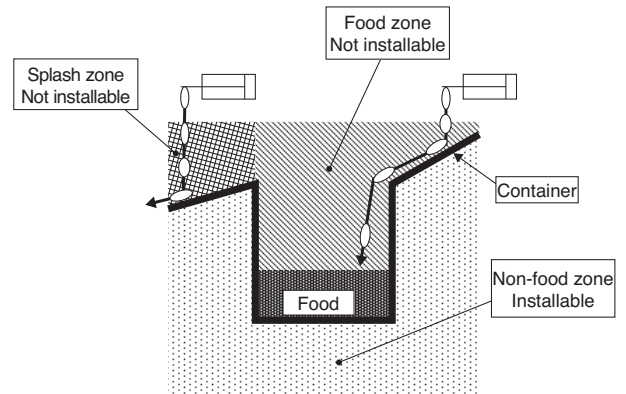

Note 1) Avoid using this product in the food zone. (Refer to the figure above.)

Note 2) When the product is used in an area of liquid splash, or a water resistant function is required for the product, please consult SMC.

Note 3) Operate without lubrication from a pneumatic system lubricator.

Note 4) Use the following grease pack for the maintenance work.
GR-H-010 (Grease: 10 g)

Note 5) Please contact SMC for details on the maintenance intervals for this cylinder, which differ from those of the standard cylinder.

Standard

Large Bore
Size

Long Stroke

Non-rotating
Rod

Axial Piping

Anti-lateral
Load

With End Lock

Water
Resistant

With Auto
Switch

Auto Switch

Made to Order

Made to Order Common Specifications: -XC92: Dust Resistant Actuator

60 Dust Resistant Actuator

Symbol
-XC92

Applicable for environments with flying micro-powder (20 to 30 μm or less) such as ceramic powder, toner powder, paper powder, and metallic powder (except weld spatter). 4 times stronger than the standard model

Applicable series

Series	Description/Type	Model	Action	Remark (s)
CQ2	Standard type	CQ2	Double acting, Single rod	Applicable to ø32 to ø100.

C(D)Q2 **Mounting bracket** **Bore size** — **Stroke** **D** **Body option** **Z** — **Auto switch** **Suffix** — **XC92**

Dust Resistant Cylinder

* Body option with rear slip fit is not available.

Bore size (mm)	Standard stroke	Minimum operating pressure
32, 40	5, 10, 15, 20, 25, 30, 35, 40, 45, 50, 75, 100	0.1 MPa
50 to 100	10, 15, 20, 25, 30, 35, 40, 45, 50, 75, 100	0.1 MPa

Series CQ2

2 x ø5.5 through
2 x 2 x ø9 counterbore depth 17
(Bottom side counterbore depth 7)

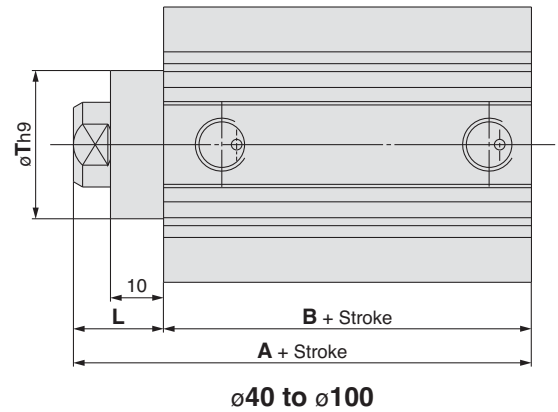
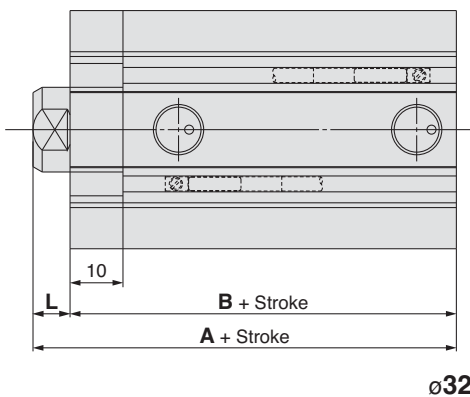

Bore size (mm)	A		B		L	T
	Without auto switch	With auto switch	Without auto switch	With auto switch		
32	40 (50)	50	33 (43)	43	7	—
40	46.5 (56.5)	56.5	29.5 (39.5)	39.5	17	28
50	48.5 (58.5)	58.5	30.5 (40.5)	40.5	18	35
63	54 (64)	64	36 (46)	46	18	35
80	63.5 (73.5)	73.5	43.5 (53.5)	53.5	20	43
100	75 (85)	85	53 (63)	63	22	59

(mm)

Note 1) For cylinders with rubber bumper, stroke tolerance does not include the amount of bumper change.

Note 2) Dimensions inside () are for 75, 100st.

Series CQ2

Made to Order Individual Specifications 1

Please contact SMC for detailed dimensions, specifications, and lead times.



Symbol

-X144 Special Port Location

For changing port location ($\phi 12$ to $\phi 25$ with auto switch only)

How to Order

CDQ2 Standard model no. - X144 B

Special port location

In the case of CDQ2□20/25,
specify the port location
with B, C and D.

Applicable Model

Action	Note
Double acting, Single rod	Applicable to $\phi 12$ to $\phi 25$
Double acting, Double rod	
Single acting (Spring return/extend)	

Note) The specifications are the same as those of the CDQ2 series.

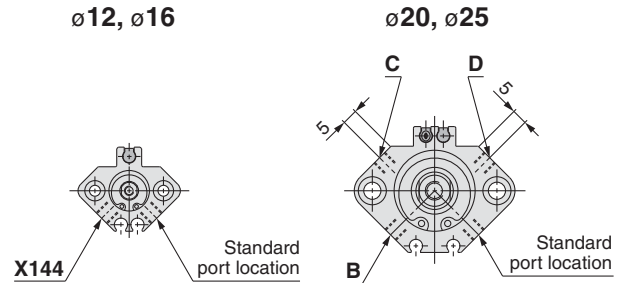

Standard

Large Bore Size

Long Stroke

Non-rotating Rod

Axial Piping

Anti-lateral Load

With End Lock

Water Resistant

With Auto Switch

Auto Switch

Made to Order

Series CQ2

Made to Order Individual Specifications 2

Please contact SMC for detailed dimensions, specifications, and lead times.



Symbol

-X202 Full Length Dimension is the Same as the CQ1 Series.

C□Q2 **Mounting** **Bore size** — **Stroke** **Action** **Option** (Z) — X202

In a single rod cylinder of the CQ2 series, the A dimension (from the head face to the rod end) and the rod end female thread size are the same as those of the CQ1 series (former model).

Applicable Model

Action		Note
Single rod	Double acting (Rubber bumper)	Applicable to $\phi 12$, $\phi 20$, $\phi 32$, $\phi 40$, $\phi 50$, $\phi 63$, $\phi 80$, $\phi 100$
	Single acting (Spring return/ Spring extend)	Applicable to $\phi 12$, $\phi 20$, $\phi 32$, $\phi 40$, $\phi 50$

Note 1) $\phi 16$ and $\phi 25$ are the new models so that they are not applicable.
Note 2) Strokes except mentioned below are available as standard products.

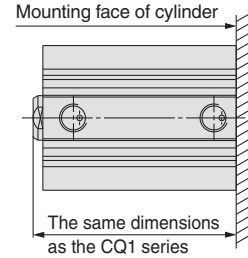

The specifications are the same as those of the standard, CQ2 series.

Dimensions (Without auto switch)

Double acting,
Single rod: Female thread

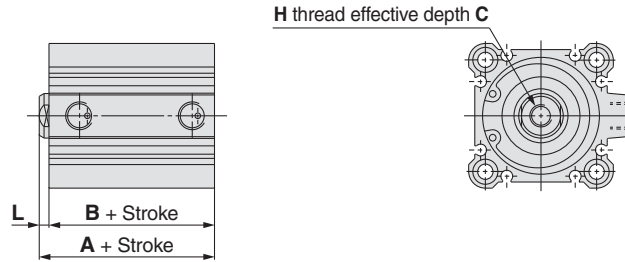

Symbol	Bore size		$\phi 12$		$\phi 20$		$\phi 32$		$\phi 40$		$\phi 50$		$\phi 63$		$\phi 80$		$\phi 100$	
	Stroke (mm)		15, 25	5, 10 20, 30 40, 50	15, 25 35, 45	5, 10 20, 30 40, 50	15, 25 35, 45	5, 10 20, 30 40, 50	15, 25 35, 45	10, 20 30, 40 50	15, 25 35, 45	10, 20 30, 40 50	15, 25 35, 45	10, 20 30, 40 50	15, 25 35, 45	10, 20 30, 40 50	15, 25 35, 45	
A			25.5	23(25)	28	26.5 (28.5)	31.5	33	38	34	39	39.5	44.5	47	52	56.5	61.5	
B			22	19.5	24.5	23	28	29.5	34.5	30.5	35.5	36	41	43.5	48.5	53	58	
L			3.5	3.5 (5.5)	3.5	3.5 (5.5)	3.5	3.5	3.5	3.5	3.5	3.5	3.5	3.5	3.5	3.5	3.5	
H			M3 x 0.5	M5 x 0.8		M6 x 1.0*		M6 x 1.0*		M8 x 1.25*		M10 x 1.5		M16 x 2.0		M20 x 2.5		
C			6	7		9*		11*		13*		15		21		27		

Note) (:): Stroke 10 mm * The H/C dimensions of $\phi 32$, $\phi 40$ and $\phi 50$ are different from those of the new CQ2 series model.

75 st, 100 st

Symbol	Bore size		$\phi 32$		$\phi 40$		$\phi 50$		$\phi 63$		$\phi 80$		$\phi 100$	
	Stroke		75	100	75	100	75	100	75	100	75	100	75	100
A			36.5	43	44	49.5	57	66.5						
B			33	39.5	40.5	46	53.5	63						
L			3.5	3.5	3.5	3.5	3.5	3.5						

Note) The H/C dimensions are the same as above.

Single acting

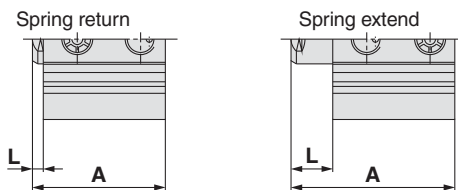

Double acting: Rod end male thread

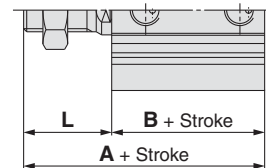

Action	Bore size		$\phi 20$		$\phi 32$		$\phi 40$		$\phi 50$	
	Stroke		5	10	5	10	5	10	10	20
Single acting, Spring return	A		28	35	31.5	38.5	38	43	44	54
	L		3.5	5.5	3.5	5.5	3.5		3.5	
Single acting, Spring extend	A		33	45	36.5	48.5	43	53	54	74
	L		8.5	15.5	8.5	15.5	8.5	13.5	13.5	23.5

Symbol	Bore size		$\phi 12$		$\phi 20$		$\phi 32$		$\phi 40$		$\phi 50$		$\phi 63$		$\phi 80$		$\phi 100$	
	Stroke		15, 25	10	15, 25 35, 45	10	15, 25 35, 45	15, 25 35, 45	15, 25 35, 45	15, 25 35, 45	15, 25 35, 45	15, 25 35, 45	15, 25 35, 45	15, 25 35, 45	15, 25 35, 45			
A			36	40	43	53.5	56.5	63	69	74.5	92	101.5						
B			22	19.5	24.5	23	28	34.5	35.5	41	48.5	58						
L			14	20.5	18.5	30.5	28.5	28.5	33.5	33.5	43.5	43.5						

Symbol
-X202

Dimensions (With auto switch)

Double acting, Single rod: Female thread

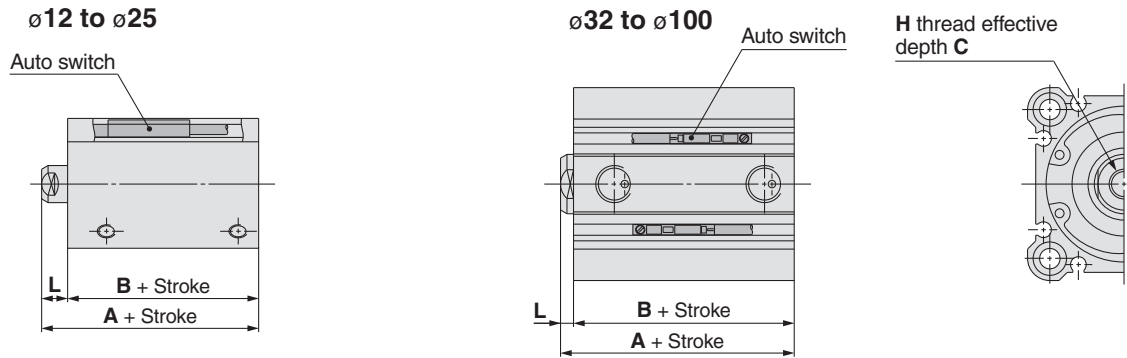

Bore size	ø12	ø20	ø32	ø40	ø50	ø63	ø80	ø100							
Stroke (mm)	15, 25	5, 10, 20 30, 40, 50	15, 25 35, 45	10, 20, 30 40, 50, 75 100	5, 15, 25 35, 45	10, 20, 30 40, 50, 75 100	15, 25 35, 45	10, 20, 30 40, 50, 75 100							
Symbol															
A	36.5	38.5	43.5	36.5	41.5	43	48	44	49	49.5	54.5	57	62	66.5	71.5
B	33	31.5	36.5	33	38	39.5	44.5	40.5	45.5	46	51	53.5	58.5	63	68
L	3.5	7	7	3.5	3.5	3.5	3.5	3.5	3.5	3.5	3.5	3.5	3.5	3.5	3.5
H	M3 x 0.5	M5 x 0.8	M6 x 1.0*	M6 x 1.0*	M8 x 1.25*	M10 x 1.5	M16 x 2.0	M20 x 2.5							
C	6	7	9*	11*	13*	15	21	27							

* The H/C dimensions of ø32, ø40 and ø50 are different from those of the new CQ2 series model.

Double acting: Rod end male thread

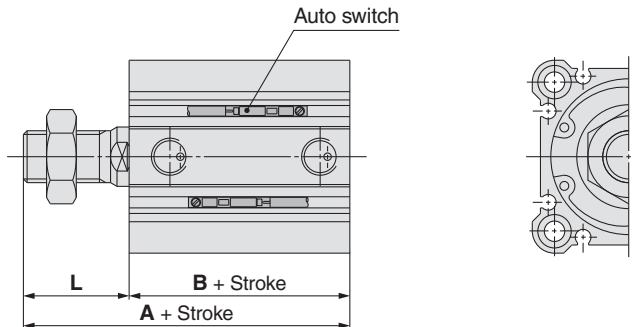

Bore size	ø12	ø20	ø32	ø40	ø50	ø63	ø80	ø100
Stroke (mm)	15, 25	5, 10 20, 30 40, 50	15, 25 35, 45	5, 15, 25 35, 45	5, 15, 25 35, 45	15, 25 35, 45	15, 25 35, 45	15, 25 35, 45
Symbol								
A	47	53.5	58.5	66.5	73	79	84.5	102
B	33	31.5	36.5	38	44.5	45.5	51	58.5
L	14	22	22	28.5	28.5	33.5	33.5	43.5

- Standard
- Large Bore Size
- Long Stroke
- Non-rotating Rod
- Axial Piping
- Anti-lateral Load
- With End Lock
- Water Resistant
- With Auto Switch
- Auto Switch
- Made to Order

Series CQ2

Made to Order Individual Specifications 3

Please contact SMC for detailed dimensions, specifications, and lead times.



Symbol

-X203 L Dimension from Rod Cover is the Same as the CQ1 Series.

C□Q2 **Mounting** **Bore size** — 10 **Action** **Option** Z — X203

In a single rod cylinder of the CQ2 series, the L dimension (from the rod face to the rod end) and the rod end female thread size are the same as the CQ1 series (former model).

Applicable Model

Action		Note	
Single rod	Female thread	Double acting Rubber bumper	Applicable to $\phi 20$, $\phi 32$, ($\phi 40$), ($\phi 50$), ($\phi 63$), ($\phi 80$), ($\phi 100$)
		Single acting (Spring return, Spring extend)	Applicable to $\phi 20$, $\phi 32$, ($\phi 40$), ($\phi 50$)
	Male thread	Available as the standard, CQ2 series	

Note 1) $\phi 16$ and $\phi 25$ are the new models so that they are not applicable.
Note 2) (): Same dimensions as for those of -X202

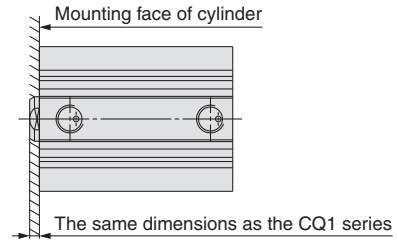

The specifications are the same as those of the standard, CQ2 series.

Dimensions: Applicable to CQ2B²⁰/₃₂-10D(C)Z Only

Double acting, Single rod

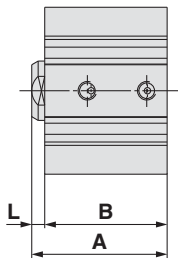

Symbol	Bore size	
	$\phi 20$	$\phi 32$
A	33	36.5
B	29.5	33
L	3.5	3.5

Single acting, Spring return

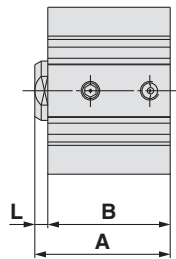

Symbol	Bore size	
	$\phi 20$	$\phi 32$
A	33	36.5
B	29.5	33
L	3.5	3.5

Single acting, Spring extend

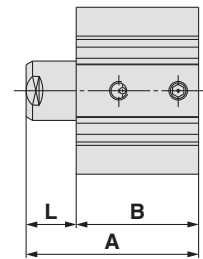

Symbol	Bore size	
	$\phi 20$	$\phi 32$
A	43	46.5
B	29.5	33
L	13.5	13.5

With Auto Switch: Applicable to CDQ2B-□D(C)Z Only

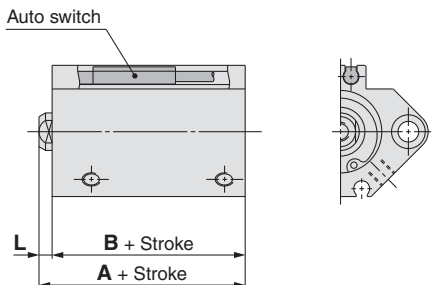

Symbol	Bore size $\phi 20$	
	Stroke	Stroke
A	5, 10 20, 30 40, 50	15, 25 35, 45
B	35	40
L	31.5	36.5
	3.5	3.5

Symbol

-X235 Special Rod End for Double Rod Cylinder

Male thread is used at one piston rod end of double rod cylinder and female thread is used at the other end.

C□Q2W **Mounting** **Bore size** — **Stroke** **D** (Z) — **X235**

“D” in the case of “-X235” ●

● Piston rod end
Male thread, Female thread

* Specifications: Same as standard

Note) For mounting a bracket, please contact SMC.

∅12 to ∅25

∅32 to ∅200

∅12 to ∅25 (With auto switch)

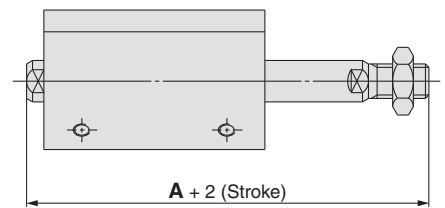
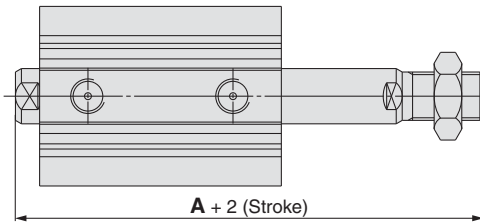
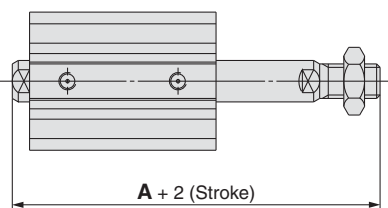

Symbol \ Bore size	12	16	20	25	32	40	50	63	80	100	125	140	160	180	200
A	42.7 (49.9)	45 (55)	49 (61)	56.5 (66.5)	66 (76)	75.5 (85.5)	82 (92)	83.5 (93.5)	104.5 (114.5)	116 (126)	157	157	172	183	190
Applicable stroke	5 to 30		5 to 50		5 to 100		10 to 100			10 to 300					

Note 1) Applicable stroke: Available in 5 mm intervals

Note 2) (): Dimensions with auto switch

Symbol

-X271 Fluororubber Seals

Material for seals has been changed to fluororubber.

C□Q2 **Standard model no.** — **X271**

● Fluororubber seals ●

* All variations except non-rotating rod is available.

Only ∅125 to ∅160 is available for the large bore size type.

The specifications are the same as for each variation of the CQ2 series.

Note) With rubber bumper: There is no change of the bumper material.

- Standard
- Large Bore Size
- Long Stroke
- Non-rotating Rod
- Axial Piping
- Anti-lateral Load
- With End Lock
- Water Resistant
- With Auto Switch
- Auto Switch
- Made to Order

Series CQ2

Made to Order Individual Specifications 4

Please contact SMC for detailed dimensions, specifications, and lead times.



Symbol

-X293 Full Length Dimension is the Same as the CQ1W Series.

C□Q2W Standard model no. — X293

The same dimensions as the CQ1W ↓

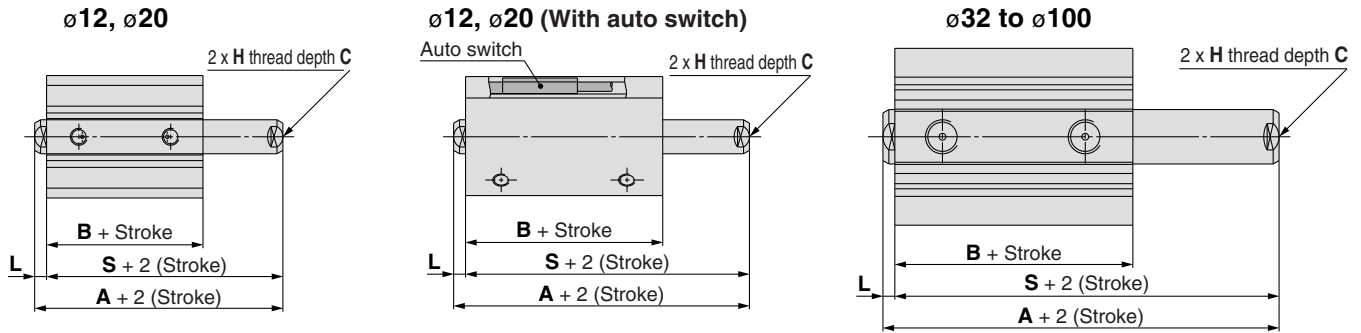

Without Auto Switch

Bore size Stroke (mm)	12		20		32		40		50		63		80		100	
	5	10	5	15	5	15	5, 10	15	10, 20	15	10, 20	15	10, 20	15	10, 20	15
Symbol	5	10	5	15	5	15	5, 10	15	10, 20	15	10, 20	15	10, 20	15	10, 20	15
A	33	33	38	37	38	43	46.5	51.5	47.5	52.5	53	58	60.5	65.5	70	75
B	25.2	26	31	30.5	30.5	35.5	40	45	40.5	45.5	42	47	51	56	60.5	65.5
L	3.5	3.5	3.5	3.5	3.5	3.5	3.5	3.5	3.5	3.5	3.5	3.5	3.5	3.5	3.5	3.5
S	29.5	29.5	34.5	33.5	34.5	39.5	43	48	44	49	49.5	54.5	57	62	66.5	71.5
H	M3 x 0.5	M5 x 0.8	M5 x 0.8	M6 x 1	M6 x 1	M6 x 1	M6 x 1	M6 x 1	M8 x 1.25	M8 x 1.25	M10 x 1.5	M10 x 1.5	M16 x 2	M16 x 2	M20 x 2.5	M20 x 2.5
C	6	7	7	9	9	9	9	9	13	13	15	15	21	21	27	27

With Auto Switch

Bore size Stroke (mm)	12		20		32		40		50		63		80		100	
	5	10	5	15	10	15	10	15	10	15	10	15	10	15	10	15
Symbol	5 <td>10 <td>5 <td>15 <td>10 <td>15 <td>10 <td>15 <td>10 <td>15 <td>10 <td>15 <td>10 <td>15 <td>10 <td>15 </td></td></td></td></td></td></td></td></td></td></td></td></td></td></td>	10 <td>5 <td>15 <td>10 <td>15 <td>10 <td>15 <td>10 <td>15 <td>10 <td>15 <td>10 <td>15 <td>10 <td>15 </td></td></td></td></td></td></td></td></td></td></td></td></td></td>	5 <td>15 <td>10 <td>15 <td>10 <td>15 <td>10 <td>15 <td>10 <td>15 <td>10 <td>15 <td>10 <td>15 </td></td></td></td></td></td></td></td></td></td></td></td></td>	15 <td>10 <td>15 <td>10 <td>15 <td>10 <td>15 <td>10 <td>15 <td>10 <td>15 <td>10 <td>15 </td></td></td></td></td></td></td></td></td></td></td></td>	10 <td>15 <td>10 <td>15 <td>10 <td>15 <td>10 <td>15 <td>10 <td>15 <td>10 <td>15 </td></td></td></td></td></td></td></td></td></td></td>	15 <td>10 <td>15 <td>10 <td>15 <td>10 <td>15 <td>10 <td>15 <td>10 <td>15 </td></td></td></td></td></td></td></td></td></td>	10 <td>15 <td>10 <td>15 <td>10 <td>15 <td>10 <td>15 <td>10 <td>15 </td></td></td></td></td></td></td></td></td>	15 <td>10 <td>15 <td>10 <td>15 <td>10 <td>15 <td>10 <td>15 </td></td></td></td></td></td></td></td>	10 <td>15 <td>10 <td>15 <td>10 <td>15 <td>10 <td>15 </td></td></td></td></td></td></td>	15 <td>10 <td>15 <td>10 <td>15 <td>10 <td>15 </td></td></td></td></td></td>	10 <td>15 <td>10 <td>15 <td>10 <td>15 </td></td></td></td></td>	15 <td>10 <td>15 <td>10 <td>15 </td></td></td></td>	10 <td>15 <td>10 <td>15 </td></td></td>	15 <td>10 <td>15 </td></td>	10 <td>15 </td>	15
A	40	47	52	48	53	56.5	61.5	57.5	62.5	63	68	70.5	75.5	80	85	
B	32.4	38	43	40.5	45.5	50	55	50.5	55.5	52	57	61	66	70.5	75.5	
L	3.5	3.5	3.5	3.5	3.5	3.5	3.5	3.5	3.5	3.5	3.5	3.5	3.5	3.5	3.5	
S	36	43.5	48.5	44.5	49.5	53	58	54	59	59.5	64.5	67	72	76.5	81.5	
H	M3 x 0.5	M5 x 0.8	M5 x 0.8	M6 x 1	M6 x 1	M6 x 1	M6 x 1	M8 x 1.25	M8 x 1.25	M10 x 1.5	M10 x 1.5	M16 x 2	M16 x 2	M20 x 2.5	M20 x 2.5	
C	6	7	7	9	9	9	9	13	13	15	15	21	21	27	27	

Symbol

-X525 Long Stroke of Adjustable Extension Stroke Cylinder (-XC8)

C□Q2 **Mounting** **Bore size** — **Stroke** D(M)(Z) — **X525**

• Long stroke of -XC8

The specifications are the same as those of -XC8 of the CQ2 series.

Refer to "Made to Order."

Note) For tap mounting (ø12 to ø25—without switch) and bracket mounting, please contact SMC.

ø12 to ø25 (Without auto switch)

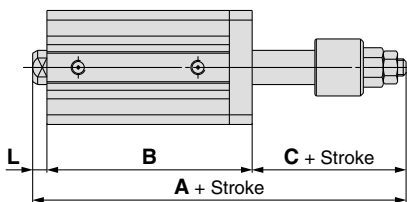

ø12 to ø25 (With auto switch)

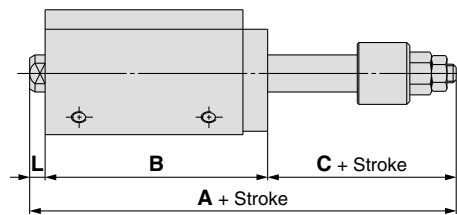

ø32 to ø100

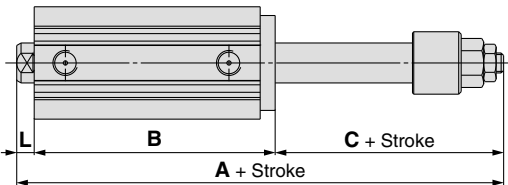

ø12, ø16

Symbol Stroke	A				B				C	L	Applicable stroke
	35st	40st	45st	50st	35st	40st	45st	50st			
Bore size 12	99.9	104.9	109.9	114.9	72.4	77.4	82.4	87.4	24	3.5	35, 40 45, 50
Bore size 16	104.5	109.9	114.9	119.5	77	82	87	92	24	3.5	

ø20 to ø100

Symbol Stroke	A						B						C	L	Applicable stroke
	55 to 75st	80 to 100st	105 to 125st	130 to 150st	155 to 175st	180 to 200st	55 to 75st	80 to 100st	105 to 125st	130 to 150st	155 to 175st	180 to 200st			
Bore size 20	155.5	180.5	—	—	—	—	122	147	—	—	—	—	29	4.5	55 to 100
Bore size 25	156	181	—	—	—	—	122	147	—	—	—	—	29	5	
Bore size 32	—	—	213.5	238.5	263.5	288.5	—	—	171.5	196.5	221.5	246.5	35	7	55 to 200
Bore size 40	—	—	223	248	273	298	—	—	181	206	231	256	35	7	
Bore size 50	—	—	235.5	260.5	285.5	310.5	—	—	183.5	208.5	233.5	258.5	44	8	
Bore size 63	—	—	237	262	287	312	—	—	187	212	237	262	42	8	
Bore size 80	—	—	260	285	310	335	—	—	198	223	248	273	52	10	
Bore size 100	—	—	273.5	298.5	323.5	348.5	—	—	209.5	234.5	259.5	284.5	52	12	

Note 1) The dimensions are the same with or without auto switch.

Note 2) Applicable stroke: Available in 5 mm intervals

- Standard
- Large Bore Size
- Long Stroke
- Non-rotating Rod
- Axial Piping
- Anti-lateral Load
- With End Lock
- Water Resistant
- With Auto Switch
- Auto Switch
- Made to Order

Series CQ2

Made to Order Individual Specifications 5

Please contact SMC for detailed dimensions, specifications, and lead times.



Symbol

-X526 Long Stroke of Adjustable Retraction Stroke Cylinder (-XC9)

C□Q2 Mounting Bore size — Stroke D(M)(Z) — X526

Long stroke of -XC9

The specifications are the same as those of -XC9 of the CQ2 series. Refer to "Made to Order."

Note) For models with a bracket, please contact SMC.

Dimensions

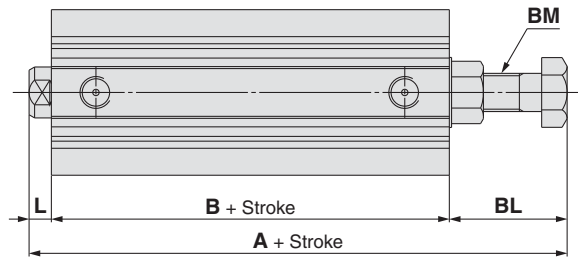

Bore size	Symbol	A	B	L	BL	BM	Applicable stroke
12		59.2 (56.4)	32.4	3.5	23.3 (20.5)	M5 x 0.8	35, 40, 45, 50
16		64	37	3.5	23.5	M6 x 1.0	
20		74	39	4.5	30.5	M8 x 1.25	75, 100
25		73.5	39	5	29.5	M8 x 1.25	
32		75.5	40.5	7	28	M8 x 1.25	75, 100, 125
40		94	50	7	37	M12 x 1.5	
50		94.5	50.5	8	36	M12 x 1.5	
63		98.5	52	8	38.5	M16 x 1.5	
80		119.5	91	10	48.5	M20 x 1.5	150, 175, 200
100		135	70.5	12	52.5	M24 x 1.5	

Note 1) (): Dimensions with auto switch

Note 2) Intermediate strokes (available in 5 mm intervals) are available with a spacer.

The dimensions are the same as those of 75, 100, 125, 150, 175, 200 mm strokes.

Symbol

-X633 Intermediate Stroke of Double Rod Cylinder

C□Q2W Standard model no. — X633
C□Q2KW

* Specifications: Same as standard

Note) For models with a bracket, please contact SMC.

Dimensions

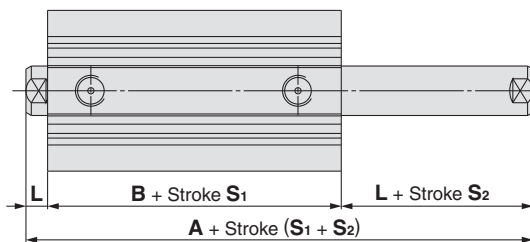

Bore size	Symbol	A	B	L	Stroke S1	Stroke S2
12		32.2 (39.4)	25.2 (32.4)	3.5	In the case of 5 to 30 stroke, 5 mm intervals	In the case of 5 to 30 stroke, 1 mm intervals
16		33 (43)	26 (36)	3.5		
20		35 (47)	26 (38)	4.5	In the case of 5 to 50 stroke, 5 mm intervals	In the case of 5 to 50 stroke, 1 mm intervals
25		39 (49)	29 (39)	5		
32		44.5 (54.5)	30.5 (40.5)	7	In the case of 5 to 50 stroke, 5 mm intervals In the case of 50 to 100 stroke, 25 mm intervals	In the case of 5 to 100 stroke, 1 mm intervals
40		54 (64)	40 (50)	7		
50		56.5 (66.5)	40.5 (50.5)	8	In the case of 10 to 50 stroke, 5 mm intervals	In the case of 10 to 100 stroke, 1 mm intervals
63		58 (68)	42 (52)	8		
80		71 (81)	51 (61)	10	In the case of 50 to 100 stroke, 25 mm intervals	In the case of 10 to 300 stroke, 1 mm intervals
100		84.5 (94.5)	60.5 (70.5)	12		
125		115	83	16	In the case of 10 to 50 stroke, 10 mm intervals	In the case of 10 to 300 stroke, 1 mm intervals
140		115	83	16		
160		125	91	17	In the case of 50 to 200 stroke, 25 mm intervals	In the case of 10 to 300 stroke, 1 mm intervals
180		136	102	17		
200		143	109	17	In the case of 200 to 300 stroke, 50 mm intervals	

Note 1) (): Dimensions with auto switch
Note 2) Installing a spacer inside the standard cylinder tube, stroke S₁ has 5 mm intervals for controlling intermediate strokes in 1 mm intervals.

Example) In the case of CDQ2WB40-18DZ, stroke S₁ is 20 mm and stroke S₂ is 18 mm.

Note 3) For ø40 to ø100 cylinders with bumper, please consult with SMC.

Symbol

-X636 Long Stroke of Dual Stroke Single Rod Cylinder

C□Q2B **Bore size** – **Stroke S₁** + **Stroke S₂–S₁** (C)(M)(Z) – X636

Long stroke of -XC11

Applicable Stroke (mm)

Bore size	Stroke
ø12, ø16	Stroke S ₂ : Up to 50 mm
ø20 to ø100	Stroke S ₂ : Up to 100 mm

The specifications are the same as those of -XC11 of the CQ2 series.
Refer to "Made to Order."
Note) For tap mounting and bracket mounting, please contact SMC.

Series CQ2

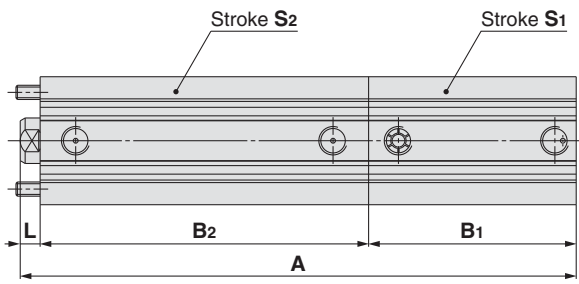

Bore Size: ø12, ø16

Symbol	A	B ₁	B ₂	L	Stroke range	
					S ₁	S ₂
Bore size						
ø12	52.9 (63.9) + Stroke (S ₁ + S ₂)	17 (28) + Stroke S ₁	32.4 + Stroke S ₂	3.5	5 to 30	35 to 50
ø16	58 (70) + Stroke (S ₁ + S ₂)	18.5 (30.5) + Stroke S ₁	36 + Stroke S ₂	3.5	5 to 30	35 to 50

Bore Size: ø20, ø25

Symbol	A		B ₁	B ₂		L	Stroke range	
	Stroke S ₂			Stroke S ₂			S ₁	S ₂
Bore size	55 to 75	80 to 100		55 to 75	80 to 100			
ø20	137 (149) + Stroke S ₁	162 (174) + Stroke S ₁	19.5 (31.5) + Stroke S ₁	113	138	4.5	5 to 50	55 to 100
ø25	141.5 (151.5) + Stroke S ₁	166.5 (176.5) + Stroke S ₁	22.5 (32.5) + Stroke S ₁	114	139	5	5 to 50	55 to 100

Bore Size: ø32 to ø100

Symbol	A					B ₁			B ₂		L	Stroke range	
	Stroke S ₂ 55 to 75		Stroke S ₂ 80 to 100			Stroke S ₁			Stroke S ₂			S ₁	S ₂
	Stroke S ₁		Stroke S ₁			50	55 to 75	80 to 100	55 to 75	80 to 100			
Bore size	55	55 to 75	50	55 to 75	80 to 100	50	55 to 75	80 to 100	55 to 75	80 to 100			
ø32	145.4 (155.5) + Stroke S ₁	230.5	170.5 (180.5) + Stroke S ₁	255.5	280.5	23 (33) + Stroke S ₁	108	133	115.5	140.5	7	5 to 100	55 to 100
ø40	161.5 (171.5) + Stroke S ₁	246.5	186.5 (196.5) + Stroke S ₁	271.5	296.5	29.5 (39.5) + Stroke S ₁	114.5	139.5	125	150	7	5 to 100	55 to 100
ø50	164 (174) + Stroke S ₁	249	189 (199) + Stroke S ₁	274	299	30.5 (40.5) + Stroke S ₁	115.5	140.5	125.5	150.5	8	10 to 100	55 to 100
ø63	171 (181) + Stroke S ₁	256	196 (206) + Stroke S ₁	281	306	36 (46) + Stroke S ₁	121	146	127	152	8	10 to 100	55 to 100
ø80	189.5 (199.5) + Stroke S ₁	274.5	214.5 (224.5) + Stroke S ₁	299.5	324.5	43.5 (53.5) + Stroke S ₁	128.5	153.5	136	161	10	10 to 100	55 to 100
ø100	210.5 (220.5) + Stroke S ₁	295.5	235.5 (245.5) + Stroke S ₁	320.5	345.5	53 (63) + Stroke S ₁	138	163	145.5	170.5	12	10 to 100	55 to 100

Note 1 (): Dimensions with auto switch
Note 2) Applicable stroke: Available in 5 mm intervals

Standard

Large Bore Size

Long Stroke

Non-rotating Rod

Axial Piping

Anti-lateral Load

With End Lock

Water Resistant

With Auto Switch

Auto Switch

Made to Order

Series CQ2

Made to Order Individual Specifications 6

Please contact SMC for detailed dimensions, specifications, and lead times.



Symbol

-X1876 Cylinder Tube: With Concave Boss on Head Side

C□Q2
C□Q2K
C□Q2□S

Mounting

Bore size

Stroke

D(C)(M)(Z)
S(M)(Z)
T(M)(Z) — X1876

• With concave boss on head side

The specifications are the same as those of the CQ2 series.

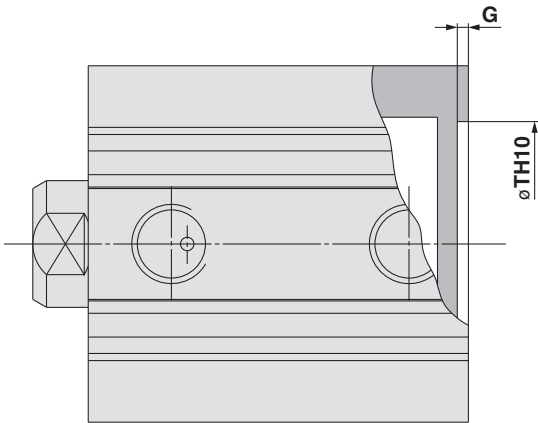

Note) Except $\phi 12$, $\phi 16$ and $\phi 125$ to $\phi 200$



Bore size (mm)	TH10	G
20	19.3 ^{+0.084} ₀	1.4
25	23.8 ^{+0.084} ₀	1.4
32	30.9 ^{+0.100} ₀	1.4
40	39.3 ^{+0.100} ₀	1.3
50	48.7 ^{+0.100} ₀	2.1
63	61.5 ^{+0.120} ₀	2.4
80	78.3 ^{+0.120} ₀	2.7
100	98.9 ^{+0.140} ₀	2.8

Safety Instructions

These safety instructions are intended to prevent hazardous situations and/or equipment damage. These instructions indicate the level of potential hazard with the labels of “**Caution**,” “**Warning**” or “**Danger**.” They are all important notes for safety and must be followed in addition to International Standards (ISO/IEC)*1), and other safety regulations.

-  **Caution:** **Caution** indicates a hazard with a low level of risk which, if not avoided, could result in minor or moderate injury.
-  **Warning:** **Warning** indicates a hazard with a medium level of risk which, if not avoided, could result in death or serious injury.
-  **Danger:** **Danger** indicates a hazard with a high level of risk which, if not avoided, will result in death or serious injury.

- *1) ISO 4414: Pneumatic fluid power – General rules relating to systems.
ISO 4413: Hydraulic fluid power – General rules relating to systems.
IEC 60204-1: Safety of machinery – Electrical equipment of machines.
(Part 1: General requirements)
ISO 10218-1: Manipulating industrial robots - Safety.
etc.

Warning

- 1. The compatibility of the product is the responsibility of the person who designs the equipment or decides its specifications.**
Since the product specified here is used under various operating conditions, its compatibility with specific equipment must be decided by the person who designs the equipment or decides its specifications based on necessary analysis and test results. The expected performance and safety assurance of the equipment will be the responsibility of the person who has determined its compatibility with the product. This person should also continuously review all specifications of the product referring to its latest catalogue information, with a view to giving due consideration to any possibility of equipment failure when configuring the equipment.
- 2. Only personnel with appropriate training should operate machinery and equipment.**
The product specified here may become unsafe if handled incorrectly. The assembly, operation and maintenance of machines or equipment including our products must be performed by an operator who is appropriately trained and experienced.
- 3. Do not service or attempt to remove product and machinery/equipment until safety is confirmed.**
 1. The inspection and maintenance of machinery/equipment should only be performed after measures to prevent falling or runaway of the driven objects have been confirmed.
 2. When the product is to be removed, confirm that the safety measures as mentioned above are implemented and the power from any appropriate source is cut, and read and understand the specific product precautions of all relevant products carefully.
 3. Before machinery/equipment is restarted, take measures to prevent unexpected operation and malfunction.
- 4. Contact SMC beforehand and take special consideration of safety measures if the product is to be used in any of the following conditions.**
 1. Conditions and environments outside of the given specifications, or use outdoors or in a place exposed to direct sunlight.
 2. Installation on equipment in conjunction with atomic energy, railways, air navigation, space, shipping, vehicles, military, medical treatment, combustion and recreation, or equipment in contact with food and beverages, emergency stop circuits, clutch and brake circuits in press applications, safety equipment or other applications unsuitable for the standard specifications described in the product catalogue.
 3. An application which could have negative effects on people, property, or animals requiring special safety analysis.
 4. Use in an interlock circuit, which requires the provision of double interlock for possible failure by using a mechanical protective function, and periodical checks to confirm proper operation.

Caution

- 1. The product is provided for use in manufacturing industries.**
The product herein described is basically provided for peaceful use in manufacturing industries.
If considering using the product in other industries, consult SMC beforehand and exchange specifications or a contract if necessary.
If anything is unclear, contact your nearest sales branch.

Limited warranty and Disclaimer/ Compliance Requirements

The product used is subject to the following “Limited warranty and Disclaimer” and “Compliance Requirements”.

Read and accept them before using the product.

Limited warranty and Disclaimer

1. The warranty period of the product is 1 year in service or 1.5 years after the product is delivered.*2)
Also, the product may have specified durability, running distance or replacement parts. Please consult your nearest sales branch.
2. For any failure or damage reported within the warranty period which is clearly our responsibility, a replacement product or necessary parts will be provided.
This limited warranty applies only to our product independently, and not to any other damage incurred due to the failure of the product.
3. Prior to using SMC products, please read and understand the warranty terms and disclaimers noted in the specified catalogue for the particular products.

*2) Vacuum pads are excluded from this 1 year warranty.

A vacuum pad is a consumable part, so it is warranted for a year after it is delivered. Also, even within the warranty period, the wear of a product due to the use of the vacuum pad or failure due to the deterioration of rubber material are not covered by the limited warranty.

Compliance Requirements

1. The use of SMC products with production equipment for the manufacture of weapons of mass destruction (WMD) or any other weapon is strictly prohibited.
2. The exports of SMC products or technology from one country to another are governed by the relevant security laws and regulations of the countries involved in the transaction. Prior to the shipment of a SMC product to another country, assure that all local rules governing that export are known and followed.

Safety Instructions

Be sure to read “Handling Precautions for SMC Products” (M-E03-3) before using.

SMC Corporation (Europe)

Austria	☎ +43 (0)2262622800	www.smc.at	office@smc.at	Lithuania	☎ +370 5 2308118	www.smclt.lt	info@smclt.lt
Belgium	☎ +32 (0)33551464	www.smc-pneumatics.be	info@smc-pneumatics.be	Netherlands	☎ +31 (0)205318888	www.smc-pneumatics.nl	info@smc-pneumatics.nl
Bulgaria	☎ +359 (0)2807670	www.smc.bg	office@smc.bg	Norway	☎ +47 67129020	www.smc-norge.no	post@smc-norge.no
Croatia	☎ +385 (0)13707288	www.smc.hr	office@smc.hr	Poland	☎ +48 (0)222119616	www.smc.pl	office@smc.pl
Czech Republic	☎ +420 541424611	www.smc.cz	office@smc.cz	Portugal	☎ +351 226166570	www.smc.eu	postpt@smc.smces.es
Denmark	☎ +45 70252900	www.smc-dk.com	smc@smcdk.com	Romania	☎ +40 213205111	www.smcromania.ro	smcromania@smcromania.ro
Estonia	☎ +372 6510370	www.smc-pneumatics.ee	smc@smc-pneumatics.ee	Russia	☎ +7 8127185445	www.smc-pneumatik.ru	info@smc-pneumatik.ru
Finland	☎ +358 207513513	www.smc.fi	smcfi@smc.fi	Slovakia	☎ +421 (0)413213212	www.smc.sk	office@smc.sk
France	☎ +33 (0)164761000	www.smc-france.fr	promotion@smc-france.fr	Slovenia	☎ +386 (0)73885412	www.smc.si	office@smc.si
Germany	☎ +49 (0)61034026	www.smc-pneumatik.de	info@smc-pneumatik.de	Spain	☎ +34 945184100	www.smc.eu	post@smc.smces.es
Greece	☎ +30 210 2717265	www.smchellas.gr	sales@smchellas.gr	Sweden	☎ +46 (0)86031200	www.smc.nu	post@smc.nu
Hungary	☎ +36 23511390	www.smc.hu	office@smc.hu	Switzerland	☎ +41 (0)523963131	www.smc.ch	info@smc.ch
Ireland	☎ +353 (0)14039000	www.smc-pneumatics.ie	sales@smc-pneumatics.ie	Turkey	☎ +90 212 489 0 440	www.smc-pneumatik.com.tr	info@smc-pneumatik.com.tr
Italy	☎ +39 0292711	www.smc-italia.it	mailbox@smc-italia.it	UK	☎ +44 (0)845 121 5122	www.smc-pneumatics.co.uk	sales@smc-pneumatics.co.uk
Latvia	☎ +371 67817700	www.smc-lv.lv	info@smc-lv.lv				

SMC CORPORATION Akihara UDX 15F, 4-14-1, Sotokanda, Chiyoda-ku, Tokyo 101-0021, JAPAN Phone: 03-5207-8249 FAX: 03-5298-5362