

ISL78714

Automotive Grade Multi-Cell Li-Ion Battery Manager

The [ISL78714](#) automotive grade Li-ion battery manager IC supervises up to 14 series connected cells and is optimized to meet stringent automotive performance, reliability, and safety requirements. The device provides all the functions expected of such a critical component in a battery management system, such as accurate cell voltage and temperature monitoring, cell balancing, and extensive system diagnostics.

In a typical configuration, a Master ISL78714 communicates to a host microcontroller through an SPI port and up to 29 additional ISL78714 devices connected together by a robust, proprietary, two-wire Daisy Chain. This communication system is highly flexible and can be implemented with capacitor isolation, transformer isolation, or a combination of both.

Three cell balancing modes are included: Manual Balance mode, Timed Balance mode, and Auto Balance mode. Auto Balance mode terminates balancing after a host-specified amount of charge has been removed from every cell.

The ISL78714 is packaged in a 64 pin TQFP and is specified for operation from -40°C to +105°C.

Applications

- Hybrid Electric Vehicle (HEV), Plug-in Hybrid Electric Vehicle (PHEV), and Electric Vehicle (EV) battery packs
- Electric motorcycle battery packs
- Backup battery and energy storage systems requiring high accuracy management and monitoring
- Portable and semi-portable equipment

Features

- Monitors and manages up to 14 cells; all standard Li-Ion cell chemistries
- [AEC-Q100](#) qualified, supports ASIL D systems
- Robust two-wire Daisy Chain communications system using capacitor or transformer coupling at up to 1Mbps
- High security communications protocol per ISO26262
- Cell voltage measurement accuracy 1.65V to 4.28V; -20°C to +85°C:
 - Initial Device accuracy: $\pm 2\text{mV}$
 - Post board assembly Device accuracy: $\pm 2.5\text{mV}$
- Cell input range: $\pm 5.0\text{V}$, negative voltages ideal for bus bars
- Up to six external temperature monitoring inputs
- Internal temperature monitoring with warning flag
- Two general purpose I/O pins
- Automatic sensing of position in battery stack
- Measures and performs read-back on all voltages, temperatures, and diagnostics for 112 cells in less than 10ms
- User-selectable cell measurement averaging function
- 14-bit voltage and temperature measurements
- Integrated system diagnostics for all key functions
- Watchdog shuts down device if communication is lost
- Pb-free (RoHS compliant)
- Long term drift: -0.31 log(khrs)
- Fully tolerant to EMC and transients

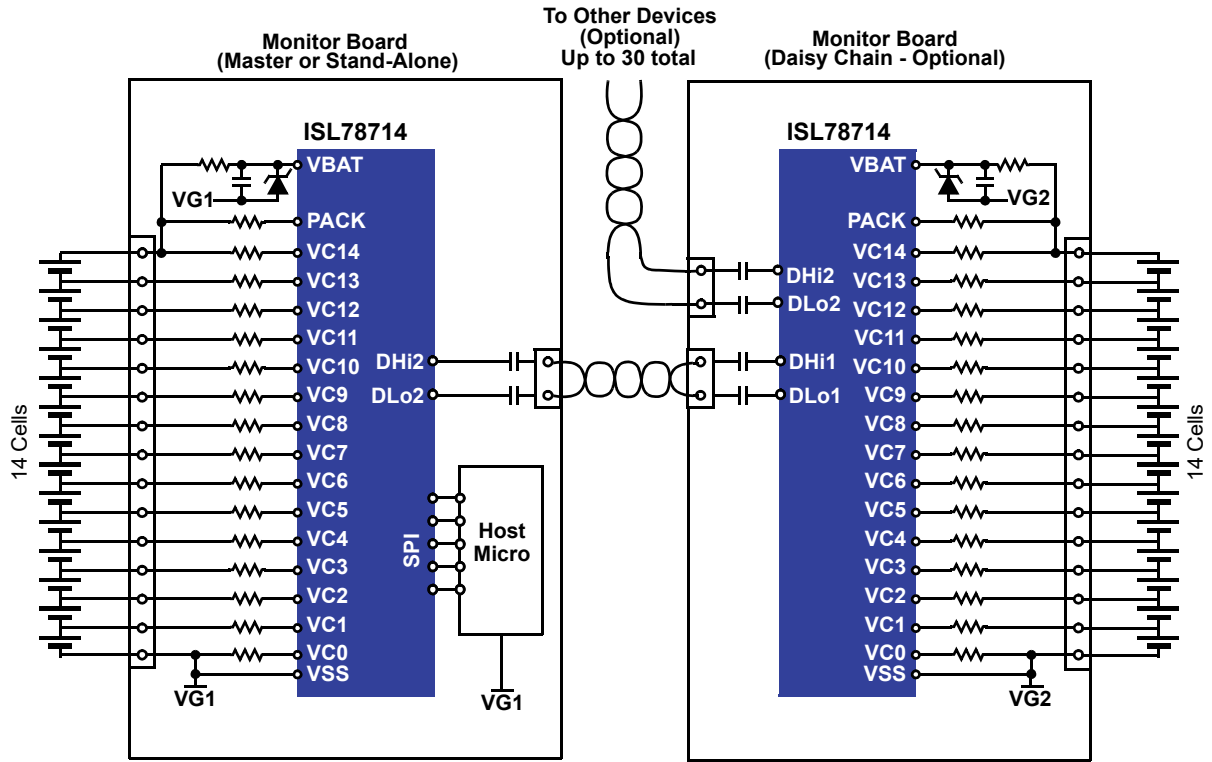

Figure 1. Typical Application