

THIS COPY IS PROVIDED ON A RESTRICTED BASIS AND IS NOT TO BE USED IN ANY WAY DETRIMENTAL TO THE INTERESTS OF PANDUIT CORP.

PANDUIT PART NUMBER	MAX. BUNDLE DIA IN (MM)	RECM. FASTENER	DIMENSIONS									WEIGHT LB./100pcs. (g)
			"A" REF	"B"	"C" REF	"D" REF	"E" REF	"F" REF	"G"	"H" REF	"J" REF	
CPH.75-S8	0.75 (19.0)	#8 SCREW (M4)	2.48 (63.0)	1.78 (45.3)	1.18 (30.0)	1.35 (34.4)	1.60 (40.8)	0.172 ±0.008 (4.4) (0.2)	0.90 (22.9)	0.528 (13.4)	0.17 (4.3)	1.4 (64)
CPL.75-S8	0.75 (19.0)	#8 SCREW (M4)	1.69 (42.9)	1.08 (27.4)	1.11 (28.2)	0.56 (14.2)	1.52 (38.6)	0.172 ±0.008 (4.4) (0.2)	0.88 (22.4)	0.568 (14.4)	0.16 (4.0)	1.0 (454)

NOTES:

1. SEE CURRENT PRICE SHEET FOR PART NUMBER SUFFIX DESIGNATION FOR PACKAGE SIZE.
2. COLOR: BLACK

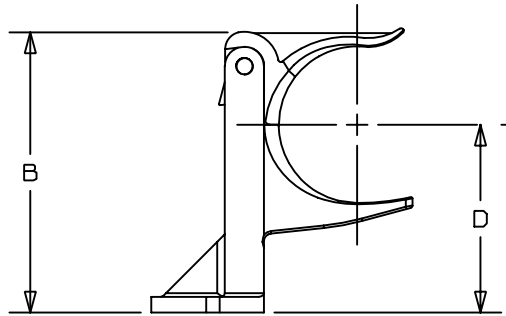
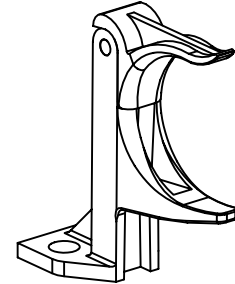
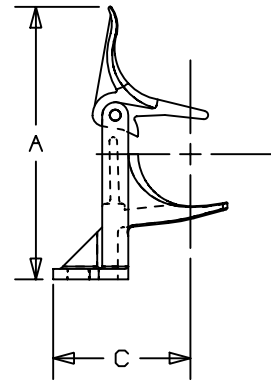
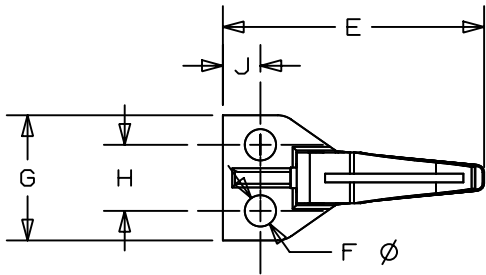

DIMENSIONS IN BRACKETS ARE METRIC [mm]	
CAD FILENAME/LAYERS G00239HJ_PI_CPHCPL_01	
PANDUIT CORP. TINLEY PARK, ILLINOIS	
CORNER POST HIGH, CPH.75-S8 CORNER POST LOW, CPL.75-S8	
UNLESS OTHERWISE SPECIFIED, DIMENSIONAL TOLERANCES ARE: (.X) ±0.05 (1.3) (.XXX) ±0.010 (0.25) (.XX) ±0.02 (0.5) ANGLES ± 5°	UNLESS OTHERWISE SPECIFIED, ALL DIMENSIONS ARE GIVEN IN INCHES, THIRD ANGLE PROJECTION.
DRAWN BY JAD	MAT'L: ACETAL
DATE 6/14/01	SCALE NONE
REV 1	DRAWING NO. G00239HJ
DATE 04-22-02	DWG SIZE A
BY LGG	
CHK	
DESCRIPTION	
ECN - R	
CUST	
SUP	

1	04-22-02	LGG		CORRECT PART NAME. WAS S6 S/B S8'S	G00239HJ	1			
REV	DATE	BY	CHK	DESCRIPTION	ECN	R	CUST	SUP	