

Barcode Scanner Module

User Manual

OVERVIEW

This is a small 1D/2D codes reader, by using the intelligent image recognition algorithm, it will decode the barcode or 2D code on paper or screen, fast and accurately.

Through the onboard USB and UART interface, it can be directly plugged into a computer, or be easily integrated to kinds of devices due to its small form factor.

FEATURES

- Easy to use, requires no knowledges of image recognition
- Decodes various common 1D/2D codes such as Barcode, QR code etc.
- Onboard micro USB and UART serial port, allows to connect with computers or embedded devices
- Configurable via scanning 'configuration code'
- Onboard light source, works in the dark

SPECIFICATIONS

Operating voltage	5V
Operating current	135mA
Standby current	58mA
Sleep current	2mA
Operating temperature	0°C~60°C
Operating Humidity	5%~95%(Non-condensing)
Interfaces	UART、USB
Light source	White
Scan angle	Tilt 360°, Skew $\pm 65^\circ$, Pitch $\pm 60^\circ$
FOV	28°(Horizontal), 21.5°(Vertical)
Dimension	53.3mm × 21.4mm

CONTENT

Overview	1
Features.....	1
Specifications	2
Support barcodes	5
Scanning Instructions.....	6
Scanning Area.....	6
Scanning Way	7
Setting Instruction.....	9
Hardware connection.....	9
Setting Codes.....	9
Setting code	9
Restore Factory Setting.....	10
Users Default Setting	11
UART Communication	11
USB Communication	12
Scanning Mode	13
Lighting and Targeting.....	18
Ouput indication.....	19
Data Edit	23
Barcode types Enable/Diable	34
Appendix A: Default setting table	45
Appendix B: Common UART command	47
Appendix C: CODE ID List.....	48
Appendix D: ASCII table	49
Appendix E: Data Code	55

Appendix F: Save and Remove	57
UART Command	58
Read	58
Write.....	61
Save to EEPROM	63
Restore to factory setting.....	64
Erase.....	65
Address table.....	68

SUPPORT BARCODES

Barcode	Support	Support (Factory)
Codabar	✓	✓
Code 11	✓	×
Code 39/Code 93	✓	✓
UPC/EAN	✓	✓
Code 128/EAN128	✓	✓
Interleaved 2 of 5	✓	×
Matrix 2 of 5	✓	×
MSI Code	✓	×
Industrial 2 of 5	✓	×
GS1 Databar	✓	✓
QR code	✓	✓
Data Matrix	✓	✓
PDF417	✓	✓

SCANNING INSTRUCTIONS

SCANNING AREA

Scanning distance: These values are all be measured indoor (250 lux)

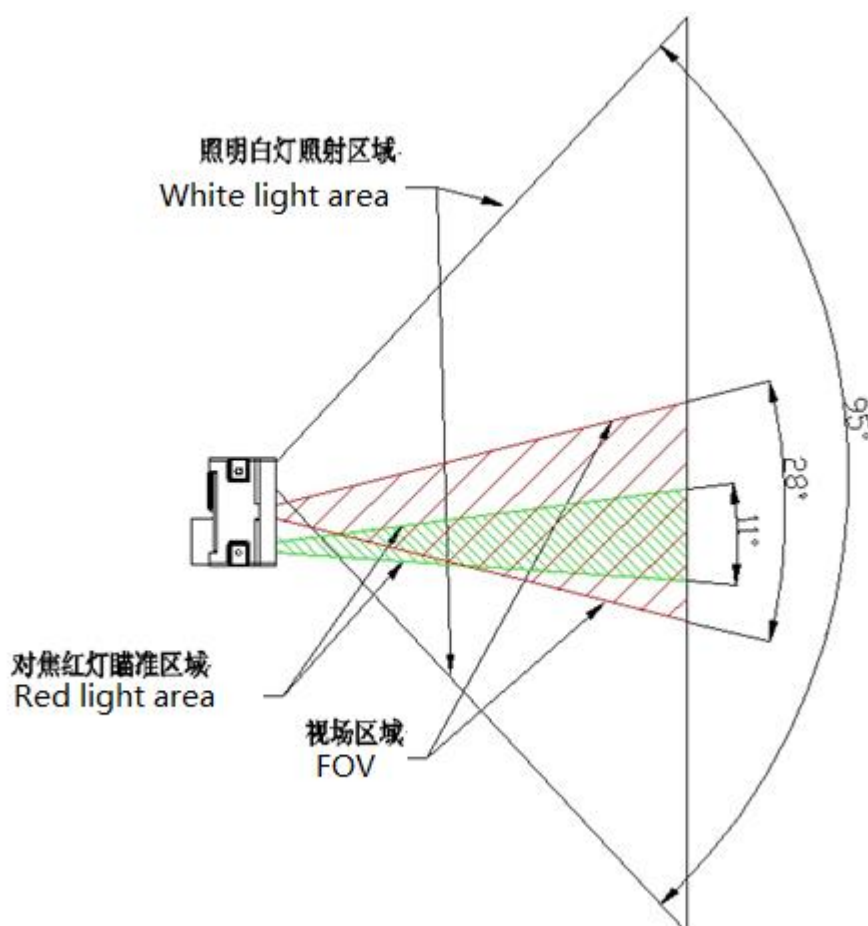

Barcode	Density	Min	Max
Code 39	0.125 mm	6.0 cm	11.0 cm
	0.375mm	6.0 cm	25.0cm
UPC/EAN	0.375mm	6.0 cm	25.0cm
Code93	0.254mm	6.0 cm	21.0cm

The min distance is based on the length of barcode and the scanning angle.

If you want to house the scanner with window, please note that:

- The window should be colorless
- Check the surface of window carefully, make sure they are clean, smooth and have not scratch.
- Let the windows cave in the case
- Paralleling window with scanner without skew. If you locate the window improperly, it will down the scanning performance.
- The window should close to and be in front of the scanner reader (don' t touch)

The distance between window and scanner protect the scanner from drop and crash.

SCANNING WAY

While using the Barcode Scanner Module to scan 1D/2D barcodes, it allows some tilt, skew and pitch. However, you had better to reduce them for better and faster scanning result.

Tilt

You must keep the barcode inside the area of white light. If the barcode is inside the scanning area, the tilt angle could be 360°. To improve the scanning rate, recommend to keep vertical scanning.

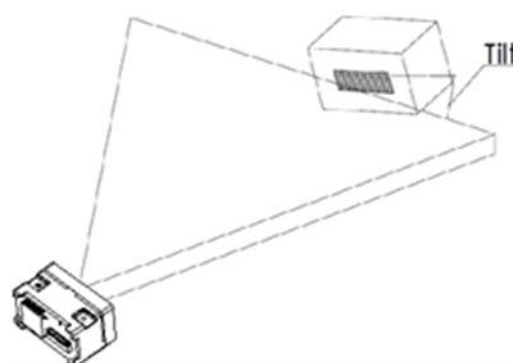

Skew

Skew will reduce the width and space of barcode (scanned), it is the threshold dimension of high density barcode. It supports up to 65° . However, you'd better reduce the skew for better and faster scanning.

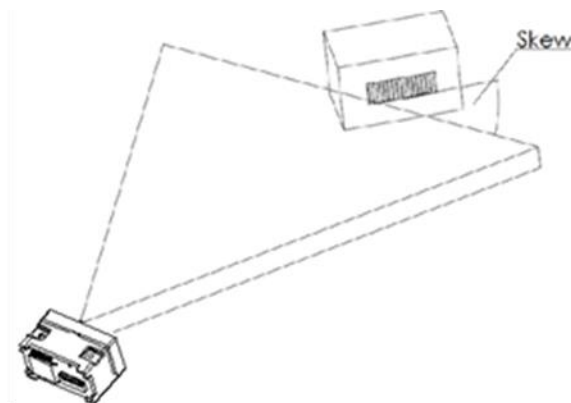

Pitch

Pitch will decrease the height of barcode. 2° to 3° is the best scanning angle, which could avoid the direct reflection of barcode. Barcode Scanner Module supports up to 60° pitch angle. But you should reduce it for better and faster scanning.

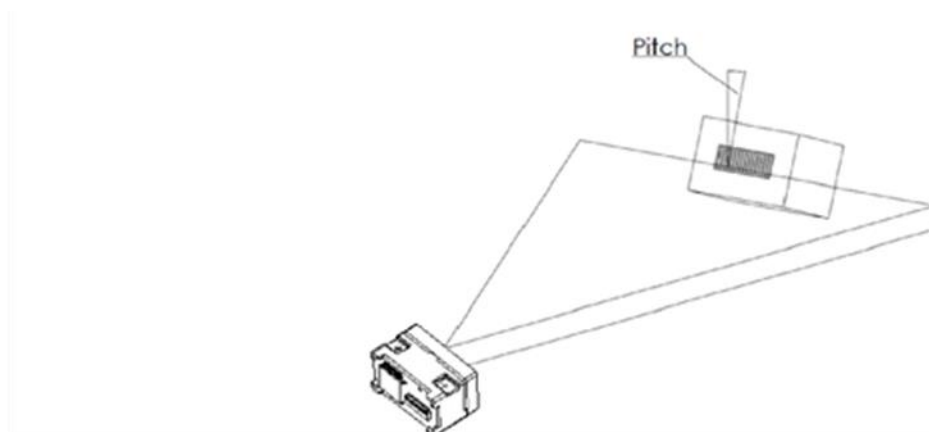

SETTING INSTRUCTION

Setting commands are provided, you could refer to this chapter to configure the Barcode Scanner Module. The factory setting could meet the requirement of common using, users need not more setting.

HARDWARE CONNECTION

This module supports two communicating interfaces. You can connect the USB interface to your device with micro USB cable. Or you can connect the UART interface to your device. If you want to test the UART interface with PC, you require an TTL to USB board like our [CP2102](#) (should be purchased separately).

VCC: 5V

Tx: Transmit Pin (Connect to Rx of MCU/CP2102)

Rx: Receive Pin (Connect to Tx of MCU/CP2102)

GND: Ground

SETTING CODES

Users could scan the setting codes to configure the Barcode Scanner Module

SETTING CODE

You can scan these two codes to enable/disable the setting code function. Enable it, you could scan setting codes for configuration. And setting code is invalid if disable.

Open/Close:



Open Setting Code Function



Close Setting Code Function

Output content:



Don't Output Content of
Setting Code



Output Content of
Setting Code

RESTORE FACTORY SETTING

You can scan this setting code to restore to factory setting if require.



Restore Factory Setting

USERS DEFAULT SETTING

Except the factory setting, users can save the setting as user default setting. By scanning the “Save Current Setting as User Default Setting” code, you can save your current setting as default setting. If there was default setting, and this operating will cover the old information.

By scanning the code “Restore User Default Setting” can restore the module to user default setting.



Save Current Setting as User
Default Setting



Restore User Default
Setting

UART COMMUNICATION

If you connect the module to MCU by UART interface. You must set the correct UART communication parameters for success communicating. The default parameters of UART interface of module are that: **Baud rate: 9600bps, Data bit: 8, Stop bit: 1**

Scanning this setting code, it switches the communication interface to UART.



UART Output

1. Baud rate Setting



1200bps



4800bps



*9600bps



14400bps



19600bps



38400bps



57600bps



115200bps

USB COMMUNICATION

1. USB PC Keyboard

When you connect the module with USB cable, you can set the module to keyboard input mode by scanning this code.



USB PC Keyboard

2. USB Virtual Port

You can set the module to USB virtual port mode by scanning this code.



USB Virtual Port

SCANNING MODE

1. Manual Mode

Manual Mode is default scanning mode. In this mode, user should press the button to begin scanning, and it will finish after scanned or button release.



Manual Mode

Sleep

In manual mode, module could enter sleep mode if it being idle for some time.

You can scan this code to configure this function.



Enable Sleep Function



Disable Sleep Function

Default setting is that the module will enter Sleep mode after 30s if module keeps idle. And you can wake it up by press button, module will restart after waking.

2. Continuous Mode

In Continuous Mode, the module will keep scanning automatically. After it success scanning and output result, or reach the timeout of scanning time, the module will begin its next scan after a certain time (configurable). User should single press the button to stop the scanning and single press again to continue.



Continuous Mode

Single Scanning Time

In Continuous Mode, this parameter set the max scanning time for per scanning behavior. If the module success scanning or the its scanning time reach the max



1000ms



3000ms



*5000ms



infinite

single scanning time, module will enter the non-scanning interval. The range of single scanning time should be 0.1~25.5s. If it is set to 0, it means that scanning time is infinite. It is 5.0s by default.

Non-Scanning Interval

It is the interval between two scanning behaviors. That is module will scan nothing after last scanning for this interval time before and begin its next scanning. The setting range of this interval is 0~25.5s. It is 1.0s by default.



No Interval



500ms



*1000ms



1500ms



2000ms

3. Sensing Mode

In Sensing Mode, the module will detect the ambient brightness, if the brightness change, module will begin scanning after an image stabilization time (configurable). After one scanning (success or timeout), module will enter detecting state again after a certain time (configurable). Module will keep this cycle unless: If timeout, module will stop scanning and in detecting state automatically. In Sensing Mode, user could also press the button to scan and module will back to detecting after success scanning or button release.



Sensing Mode

Single Scanning time

In Sensing Mode, this parameter set the max scanning time for per scanning behavior. If the module success scanning or the its scanning time reach the max single scanning time, module will enter the non-scanning interval. The range of single scanning time should be 0.1~25.5s. If it is set to 0, it means that scanning time is infinite. It is 5.0s by default



1000ms



3000ms



*5000ms



Infinite

Non-Scanning Interval

It is the interval between scanning and detecting. That is module will scan nothing after last scanning for this interval time before and begin its next detecting. The setting range of this interval is 0~25.5s. It is 1.0s by default.



No Interval



500ms



*1000ms



1500ms



2000ms

Image stabilization time

It is the time for module to stabilizing image if brightness changed is detected in sensing mode. The range is 0~25.5s, and 0.4s by default.



100ms



*400ms



1000ms



2000ms

4. Command Mode

In command mode, scanner will begin scanning after receive the command from MCU. (That is set bit0 to 1 on address 0x0002).



Command Mode

Note: The scanning command (UART) is that:7E 00 08 01 00 02 01 AB CD. The scanner module will response bytes (02 00 00 01 00 33 31) for the command and begin scanning at the same time.

Single Scanning Time

In command mode, this parameter set the max scanning time for per scanning behavior. If the module success scanning or the its scanning time reach the max single scanning time, module will enter the non-scanning interval. The range of single scanning time should be 0.1~25.5s. If it is set to 0, it means that scanning time is infinite. It is 5.0s by default.



1000ms



*5000ms



3000ms



infinite

LIGHTING AND TARGETING

1. Lighting

The white LED provides light for scanning, to improve the scanning performance and supports weak light environments. It has three states for choice:

Standard (default): The LED only turn on when scanning, or it keeps off.

Keep lighting: The LED will keep lighting after powering on scanner module

No light: The LED is turned off all the time.



*Standard



Keep lighting



No light

2. Targeting

The targeting light beam could help user to get the best scanning distance and angle. User can set it:

Standard (default): The LED only turn on when scanning, or it keeps off.

Keep lighting: The LED will keep lighting after powering on scanner module

No targeting: The LED is turned off all the time



*Standard



keep lighting



No targeting

OUTPUT INDICATION

1. All warning tones

You can set the buzzer to active/passive buzzer, as well as setting the driving frequency of passive buzzer.



Driving frequency-
Passive LF



*Driving frequency-
Passive MF



Driving frequency-
Passive HF



Driving frequency-
Active

Note:

LF: Low frequency;

MF: Midium frequency;

HF: High frequency

In active driving mode, user can set the working level of buzzer.



*Working level-
High



Working level-
Low

User can turn off all the warning tones by use the code "Enable silence" .



Enable silence



*Disable Silence

2. Scanned tone

With these code, you can set the buzzer behavior when succeed in scanning barcode.



*Open Scanned tone



Close Scanned tone

The time of the warning tone can also be set, it is default 60ms.



Tone time-30ms



*Tone time-60ms



Tone time-90ms



Tone time-120ms

3. Decoding prompt

You can enable this function for MCU to know whether succeed in decoding. After enable this function, module will send prompt character "F" if it failed decoding and "S" if success.



*Don't output decoding
prompt



Output decoding
prompt

4. Keyboard setting

To compatible with different keyboard layout of different countries. There are keyboard setting code for choosing.



*Keyboard-US



Keyboard-Czech



Keyboard-French



Keyboard-German



Keyboard-Hungarian



Keyboard-Italian



Keyboard-Japanese



Keyboard-Spanish

5. Image flip

Sometimes we may need to flip the barcode as below



original image



flip image

If your barcode is flipped, you can use the flip mode.



Enter flipped mode



*Normal mode

6. Read version information

You can read the version information of module with this setting code.



Read version information

DATA EDIT

Sometimes we need to edit the scanned data first before output for easily handling.

Data edit includes:

- Add **Prefix**
- Add **Suffix**
- Decoding **Data** intercepting
- Output **CodeID** of barcode
- **RF** information for failed decoding
- Add terminator **Tail**

The format of Data is as below after edit:

【Prefix】 【CodeID】 【Data】 【Suffix】 【Tail】

1. Prefix

Add prefix

Prefix is a definable string added in front of decoding data, user can edit it by scanning the related setting code



Allow prefix adding



Without prefix

Modify prefix

You can scan "Modify prefix" code and data setting code to modify the prefix.

Every character has two HEX and every prefix should less than 16 characters. The

Hex of character refer to Appendix D



Modify prefix

Example: Modify the prefix as "DATA"

- 1) Query the character table to get the HEX of "DATA" are that : "44" ,
"41" , " 54" , "41"

2) Make sure Setting code is enabled, if no, please scanning the setting code

“Open Setting Code Function”

3) Scanning “Modify prefix” code

4) Scanning the data setting code one by one: “4” , “4” , “4” , “1” ,

“5” , “4” , “4” , “1”

5) Scanning “Save” Setting code

2. Suffix

Add suffix

Suffix is definable string added after decoding information.



Allow Suffix Adding



*Without Suffix

Modify Suffix

The suffix can be modified as same as the Prefix.



Modify Suffix

Example: Modify the Suffix as "DATA"

- 1) Query the character table to get the HEX of "DATA" are that: "44" ,
"41" , " 54" , "41"
- 2) Make sure Setting code is enabled, if no, please scanning the setting code
"Open Setting Code Function"
- 3) Scanning "Modify prefix" code
- 4) Scanning the data setting code one by one: "4" , "4" , "4" , "1" ,
"5" , "4" , "4" , "1"
- 5) Scanning "Save" Setting code

3. CODE ID

Add CODE ID

User can use CODE ID to identify different type of barcode. CODE ID is chagnable.

Every CODE ID has one character.



Allow Adding CODE ID



*Without CODE ID

Default CODE ID

Using "Default CODE ID" code, the module will restore all barcode information to default code id. The default setting should refer to Appendix C



Default CODE ID

Change CODE ID

User can change the Code ID as they want with related setting codes. Every code id has one character (one HEX value). More details about characters, please refer to Appendix D

Example: change the CODE ID of CODE 128 to "A"

- 1) Query the HEX value of "A" is "41"
- 2) Make sure Setting code is enabled, if no, please scanning the setting code "Open Setting Code Function"
- 3) Scanning setting code "Modify CODE ID of CODE 128"
- 4) Scanning data setting codes "4" , " 1"
- 5) Scanning setting code "Save"

Change CODE ID List



Modify CODE ID of EAN 13



Modify CODE ID of EAN8



Modify CODE ID of UPCA



Modify CODE ID of UPCE0



Modify CODE ID of UPCE1



Modify CODE ID of CODE 128



Modify CODE ID of CODE 39



Modify CODE ID of CODE 93



Modify CODE ID of CODE BAR



Modify CODE ID of Interleaved

2 of 5



Modify CODE ID of
Industrial 25



Modify CODE ID of
Matrix 2 of 5



Modify CODE ID of CODE 11



Modify CODE ID of MSI



Modify CODE ID of RSS



Modify CODE ID of
Limited RSS



Modify CODE ID of
Expanded RSS



Modify CODE ID of
QR CODE



Modify CODE ID of
Data Matrix



Modify CODE ID of
Limited PDF417

4. Terminator

Scanner will output a terminator after succeed in decoding.



Close Tail



*Add Tail CR



Add Tail TAB



Add Tail CRLF

5. Data segment intercept

The decoding data 【Data】 could be divided to three parts:

【Start】 【Center】 【End】

The length of Start and End segments can be set:



*Send whole Data



Only Send Start Segment



Only Send End
Segment



Only Send Center
Segment

Change the Length M of Start

With data setting code and this one, you can change the length of Start segment.

The length of Start is max 255 characters.

The Length M is represented by a HEX. More details about HEX refer to Appendix

D



Modify the Length M

Change the Length N of End

With data setting code and this one, you can change the length of End segment.

The length of Start is max 255 characters.

The Length N is represented by a HEX. More details about HEX refer to Appendix

D



Modify the Length N

Examples:

- Decoding Data: "1234567890123ABC" , output the first thirteen bytes:
"1234567890123" (Only Start)
1) Query the characters table to get the HEX value of "13" (DEC) is "0D"

- 2) Make sure the setting code function is enable, if not, open it.
 - 3) Scanning "Modify the Length M"
 - 4) scanning setting code: "0" , "D"
 - 5) Scanning "Save"
 - 6) Scanning "Only Send Start Segment"
- Decoding Data: "1234567890123ABC" , output the last three bytes: "ABC"
(Only End)
 - 1) Query characters table, get the HEX value of "3" (DEC) is "03"
 - 2) Make sure the setting code function is enable, if not, open it.
 - 3) Scanning "Modify the length N"
 - 4) Scanning setting code: "0" . "3"
 - 5) Scanning "Save"
 - 6) Scanning "Only Send End Segment"
 - Decoding Data: "1234567890123ABC" , output the center four bytes "0123"
(Only Center)
 - 1) Query characters table, get the HEX value of "10" (DEC) and "3" are "0A"
and "03" separately
 - 2) Make sure the setting code function is enable, if not, open it.
 - 3) Scanning "Modify the Length N"
 - 4) Scanning setting code: "0" . "3"
 - 5) Scanning "Save"

- 6) Scanning "Modify the Length M"
- 7) Scanning setting code "0" , "A"
- 5) Scanning "Save"
- 6) Scanning "Only Send Center Segment"

6. RF Information

RF (Read Fail) information is the that used for indicating failed scanning in some modes.



Send RF Information



*Without RF Information

Modify Information

The RF information can be modified by users. The max length of RF is 15 and every character represented by two HEX values. (Appendix D)



Modify RF Information

Example: Modify the RF information as "FAIL"

- 1) Query characters table to get the HEX values of "FAIL" are "46" , "41" ,
"49" , "4C"
- 2) Make sure setting code function is enabled, if not, please enable it.

- 3) Scanning "Modify RF Information"
- 4) Scanning data setting code: "4" , "6" , "4" , "1" , "4" , "9" , "4" ,
"C"
- 5) Scanning "Save"

BARCODE TYPES ENABLE/DIABLE

1. All Types Enable

With these setting code, you can enable/disable all types of barcode. If you disable all types of barcode, only the setting code is scannable.



Enable All Types



Disable All Types



*Enable Default Types

2. Barcode Rotating

You can enable the function that supports 360° rotation. Disable this function can improve decoding speed.



***Enable 360° Rotation**



Disable 360° Rotation

3. EAN13

Enable/Disable EAN13 barcode



***Enable Scanning EAN13**



Disable Scanning EAN13

4. EAN8

Enable/Disable EAN9 barcode



***Enable Scanning EAN8**



Disable Scanning EAN8

5. UPCA

Enable/Disable UPCA barcode



***Enable Scanning UPCA**



Disable Scanning UPCA

6. UPCE0

Enable/Disable UPCE0 barcode



*Enable Scanning UPCE0



Disable Scanning UPCE0

7. UPCE1

Enable/Disable UPCE1 barcode



*Enable Scanning UPCE1



Disable Scanning UPCE1

8. Code128

Enable/Disable Code128 barcode



*Enable Scanning Code128



Disable Scanning Code128

Setting the Min Scannable Length of Code128:



Code128 Min Length 0



*Code128 Min Length 4

Setting the Max scannable length of Code128:



*Code128 Max Length 32



Code128 Max Length 255

9. Code 39

Enable/Disable Code39



*Enable Scanning Code39



Disable Scanning Code39

Setting the Min scannable length of Code39:



Code39 Min Length 0



*Code39 Min Length 4

Setting the Max Scannable length of Code39:



*Code39 Max Length 32



Code39 Max Length 255

10. Code93

Enable/Disable Code93 barcode



***Enable Scanning Code93**



Disable Scanning Code93

Setting the Min scannable length of Code93:



Code93 Min Length 0



***Code93 Min Length 4**

Setting the Max scannable length of Code93:



***Code93 Max Length 32**



Code93 Max Length 255

11. Code Bar

Enable/Disable Code Bar barcode



***Enable Scanning Code Bar**



Disable Scanning Code Bar

Setting Start/Stop characters of Code Bar:



Send Code Bar Start/Stop
Character



*Without Code Bar Start/Stop
Character

Setting the min scannable length of Bar Code



Code Bar Min Length 0



*Code Bar Min Length 4

Setting the max scannable length of Bar Code



*Code Bar Max Length 32



Code Bar Max Length 255

12. QR

Enable/Disable QR code



*Enable Scanning QR



Disable Scanning QR

13. Interleaved 2 of 5

Enable/Disable Interleaved 2 of 5 code



Enable Scanning Interleaved 2 of 5



*Disable Scanning Interleaved 2 of 5

Setting the min scannable length of Interleaved 2 of 5 code:



Interleaved 2 of 5 Min Length 0



* Interleaved 2 of 5 Max Length 4

Setting the max scannable length of interleaved 2 of 5 code:



* Interleaved 2 of 5 Min Length 32



Interleaved 2 of 5 Max Length 255

14. Industrial 25

Enable/Disable Industrial 25 code



Enable Scanning Industrial 25



*Disable Scanning Industrial 25

Setting the min scannable length of Industrial 25



Industrial 25 Min Length 0



* Industrial 25 max Length 4

Setting the max scannable length of Industrial 25:



* Industrial 25 Max Length 32



Industrial 25 Max Length 255

15. Matrix 2 of 5

Enable/Disable scanning Matrix 2 of 5 code:



Enable Scanning Matrix 2 of 5



*Disable Scanning Matrix 2 of 5

Setting the min scannable length of Matrix 2 of 5



Matrix 2 of 5 Min Length 0



* Matrix 2 of 5 Min Length 4

Setting the max scannable length of Matrix 2 of 5



* Matrix 2 of 5 Max Length 32



Matrix 2 of 5 Max Length 255

16. Code11

Enable/Disable Scanning Code11



Enable Scanning Code11



*Disable Scanning Code11

Setting the min scannable length of Code11:



Code11 Min Length 0



*Code11 Min Length 4

Setting the max scannable length of Code11:



*Code11 Max Length 32



Code11 Max Length 255

17. MSI

Enable/Disable scanning MSI code



Enable Scanning MSI



*Disable Scanning MSI

Setting the min scannable length of MSI:



MSI Min Length 0



*MSI Min Length 4

Setting the max scannable length of MSI:



* MSI Max Length 32



MSI Max Length 255

18. RSS

Enable/Disable scanning RSS-14



Enable Scanning RSS-14



*Disable Scanning RSS-14

Enable/Disable scanning Limited RSS



Enable Scanning Limited RSS



*Disable Scanning Limited RSS

Enable/Disable scanning Expanded RSS



Enable Scanning Expanded RSS



*Disable Scanning Expanded RSS

Setting the min scannable length of RSS



RSS Min Length 0



*RSS Min Length 4

Setting the max scannable length of RSS



* RSS Max Length 32



RSS Max Length 255

19. DM

Enable/Disable Scanning DM code



*Enable Scanning DM



Disable Scanning DM

20. PDF417

Enable/Disable scanning PDF417 code:



*Enable Scanning PDF417



Disable Scanning PDF417

APPENDIX A: DEFAULT SETTING TABLE

Parameters		Default Setting	Note
Communicating Interface			
UART	Baud rate	9600	
	Parity	None	
	Data bit	8	
	Stop bit	1	
	Flow control	None	

Mode			
Default Scanning Mode		Manual Mode	
UART Mode	Single scanning time	5s	Range: 0.1-25.5s, Step: 0.1s; 0 stands for infinite
Manual Mode	Trigger Level	Low	Default High

APPENDIX B: COMMON UART COMMAND

Functions	Commands
Set Baud rate as 9600	7E 00 08 01 00 D9 D3 20 38
Save setting to EEPROM	7E 00 09 01 00 00 DE C8
Query the baud rate	7E 00 07 01 00 2A 02 D8 0F

After sending the query command of baud rate, the module will response as below:

Return	Related Baud rate
02 00 00 02 C4 09 SS SS	1200
02 00 00 02 71 02 SS SS	4800
02 00 00 02 39 01 SS SS	9600
02 00 00 02 D0 00 SS SS	14400
02 00 00 02 9C 00 SS SS	19200
02 00 00 02 4E 00 SS SS	38400
02 00 00 02 34 00 SS SS	57600

Note: SS SS is checksum

APPENDIX C: CODE ID LIST

Barcode Type	CODE ID	Flags Address
EAN-13	d	0x91
EAN-8	d	0x92
UPC-A	c	0x93
UPC-E0	c	0x94
UPC-E1	c	0x95
Code 128	j	0x96
Code 39	b	0x97
Code 93	i	0x98
Codabar	a	0x99
Interleaved 2 of 5	e	0x9A
Industrial 2 of 5	D	0x9B
Matrix 2 of 5	v	0x9C
Code 11	H	0x9D
MSI-Plessey	m	0x9E
GS1 Databar(RSS-14)	R	0x9F
GS1 Databar Limited(RSS)	R	0xA0
GS1 Databar Expanded(RSS)	R	0xA1
QR Code	Q	0xA2
Data Matrix	u	0xA3
PDF 417	r	0xA4

APPENDIX D: ASCII TABLE

HEX	DEC	Character
0	0	NUL
1	1	SOH
2	2	STX
3	3	ETX
4	4	EOT
5	5	ENQ
6	6	ACK
7	7	BEL
8	8	BS
9	9	HT
0a	10	LF
0b	11	VT
0c	12	FF
0d	13	CR
0e	14	SO
0f	15	SI
10	16	DLE
11	17	DC1
12	18	DC2
13	19	DC3
14	20	DC4

HEX	DEC	Character
15	21	NAK
16	22	SYN
17	23	ETB
18	24	CAN
19	25	EM
1a	26	SUB
1b	27	ESC
1c	28	FS
1d	29	GS
1e	30	RS
1f	31	US
20	32	SP
21	33	!
22	34	"
23	35	#
24	36	\$
25	37	%
26	38	&
27	39	,
28	40	(
29	41)
2a	42	*

HEX	DEC	Character
2b	43	+
2c	44	,
2d	45	-
2e	46	.
2f	47	/
30	48	0
31	49	1
32	50	2
33	51	3
34	52	4
35	53	5
36	54	6
37	55	7
38	56	8
39	57	9
3a	58	:
3b	59	;
3c	60	<
3d	61	=
3e	62	>
3f	63	?
40	64	@

HEX	DEC	Character
41	65	A
42	66	B
43	67	C
44	68	D
45	69	E
46	70	F
47	71	G
48	72	H
49	73	I
4a	74	J
4b	75	K
4c	76	L
4d	77	M
4e	78	N
4f	79	O
50	80	P
51	81	Q
52	82	R
53	83	S
54	84	T
55	85	U
56	86	V

HEX	DEC	Character
57	87	W
58	88	X
59	89	Y
5a	90	Z
5b	91	[
5c	92	\
5d	93]
5e	94	^
5f	95	_
60	96	'
61	97	a
62	98	b
63	99	c
64	100	d
65	101	e
66	102	f
67	103	g
68	104	h
69	105	i
6a	106	j
6b	107	k
6c	108	l

HEX	DEC	Character
6d	109	m
6e	110	n
6f	111	o
70	112	p
71	113	q
72	114	r
73	115	s
74	116	t
75	117	u
76	118	v
77	119	w
78	120	x
79	121	y
7a	122	z
7b	123	{
7c	124	
7d	125	}
7e	126	~
7f	127	DEL

APPENDIX E: DATA CODE

0~9:



0



1



2



3



4



5



6



7



8



9

A~F:



A



B



C



D



E



F

APPENDIX F: SAVE AND REMOVE

Using Data Code, you need to scan the "Save" to save your setting, you can also use

"Remove" /" Cancele" to remove your wrong data setting if require.



Save



Exit one Data scanned before



Remove a string of Data Scanned



Cancel Modify Setting

UART COMMAND

User can set module by sending command via UART interface. Default UART parameters of scanner module are: Baud rate: 9600bps; Parity: None; Data bit: 8; Stop bit: 1

READ

For devices flag reading, supports 256 bytes for every reading.

Command format: {Head1} {Types} {Lens} {Address} {Data} {CRC}

Head1 : 0x7E 0x00 (2 bytes)

Types : 0x07 (1 byte)

Lens : 0x01 (1 byte)

Address : 0x0000~0x00FF (2 bytes) , the start address of flag read

Data : 0x00~0xFF (1 byte) , number of bytes read sequentially, 0x00 stand for 256 bytes

CRC : CRC_CCITT checksum (2 bytes). The calculate range: Types, Lens,

Address, Data; Use CRC_CCITT polynomial: $X^{16}+X^{12}+X^5+1$, whose coefficients is 0x1021. Initial value is 0, first calculate high bit for single byte without negating.

The referent C code:

```

unsigned int crc_cal_by_bit(unsigned char* ptr, unsigned int len)
{
  Unsigned int crc = 0;
  while(len-- != 0)
  {
    for(unsigned char i = 0x80; i != 0; i /= 2)
    {
      crc *= 2;
      if((crc&0x10000) != 0) //上一位 CRC 乘 2 后, 若首位是 1, 则除以
        0x11021 crc ^= 0x11021;
    }
  }
}

```

Note: Can use 0xAB 0xCD as CRC bytes if user don't need check function.

Return: {Head2} {Types} {Lens} {Data} {CRC}

1) Read successfully and return data

Head2 : 0x02 0x00

Types : 0x00 (Read Success)

Lens : Upload number of Data bytes, 0x00 stand for 256 bytes

Data : 0x00~0xFF, the data read

CRC : CRC_CCITT checksum (2 bytes). The calculate range: Types, Lens,

Address, Data; Use CRC_CCITT polynomial: $X^{16}+X^{12}+X^5+1$, whose coefficients is

0x1021. Initial value is 0, first calculate high bit for single byte without negating.

- 2) Upload CRC check failed and have no return

No return

- 3) Unknow command response

No return

Example:

Read operation on address 0x000A

- 1) Successfully reading and return data 0x3E

Command: 0x7E 0x00 0x07 0x01 0x00 0x0A 0x01 0xEE 0x8A

Return: 0x02 0x00 0x00 0x01 0x3E 0xE4 0xAC

- 2) CRC error

Command: 0x7E 0x00 0x07 0x01 0x00 0x0A 0x01 0x11 0x22

Return: None

- 3) The length of command is not enough or timeout (reach 400ms) after 0x7E 0x00

sent, it will be handled as unknow command

Command: 0x7E 0x00 0x07 0x01 0x00 0x0A 0x01

Return: None

WRITE

For every writing operation, the bytes can up to 256

Command: {Head1} {Types} {Lens} {Address} {Data} {CRC}

Head1 : 0x7E 0x00 (2 bytes)

Types : 0x08 (1 byte)

Lens : 0x00~0xFF (1 byte) , number of byte in Data segment, also the num of writing operation. 0x00 stand for 256 bytes

Address : 0x0000~0xFFFF (2 bytes) , the start address written

Data : 0x00~0xFF (1~256 bytes) , Data written

CRC : CRC_CCITT checksum (2 bytes). The calculate range: Types, Lens, Address, Data; Use CRC_CCITT polynomial: $X^{16}+X^{12}+X^5+1$, whose coefficients is 0x1021. Initial value is 0, first calculate high bit for single byte without negating. The referent code:

```
unsigned int crc_cal_by_bit(unsigned char* ptr, unsigned int len)
{
    unsigned int crc = 0;
    while(len-- != 0)
    {
        for(unsigned char i = 0x80; i != 0; i /= 2)
        {
            crc *= 2;
            if((crc&0x10000) != 0) //上一位 CRC 乘 2 后, 若首位是 1, 则除以 0x11021
                crc ^= 0x11021;
        }
    }
}
```

Note: if you don't need CRC check, just replace it with 0xAB 0xCD

Return: {Head2} {Types} {Lens} {Data} {CRC}

1) Write successfully

Head2 : 0x02 0x00

Types : 0x00 (Write successfully)

Lens : 0x01

Data : 0x00

CRC : CRC_CCITT checksum (0x33 0x31)

2) CRC check failed

No return

3) Unknow command

No return

Example:

Write 0x3E to address 0x000A

1) Write successfully

Command: 0x7E 0x00 0x08 0x01 0x00 0x0A 0x3E 0x4C 0xCF

Return: 0x02 0x00 0x00 0x01 0x00 0x33 0x31

2) CRC failed

Command: 0x7E 0x00 0x08 0x01 0x00 0x0A 0x3E 0x11 0x22

Return: None

- 3) The length of command is not enough or it is timeout after 0x7E 0x00 command sent, it will be handled as unknow command

Command: 0x7E 0x00 0x08 0x01 0x00 0x0A 0x3E

Return: None

SAVE TO EEPROM

If you want to save the setting of device to external EEPROM, you can use save command

Command: {Head1} {Types} {Lens} {Address} {Data} {CRC}

Head1 : 0x7E 0x00

Types : 0x09

Lens : 0x01

Address : 0x0000

Data : 0x00

CRC: CRC_CCITT checksum (0xDE 0xC8)

Return: {Head2} {Types} {Lens} {Data} {CRC}

- 1) Save successfully

Head2 : 0x02 0x00

Types : 0x00 (save successfully)

Lens : 0x01

Data : 0x00

CRC : CRC_CCITT checksum (0x33 0x31)

2) CRC check failed

No return

3) Unknow Command

No return

RESTORE TO FACTORY SETTING

If you want to restore devices flags to factory setting, and save to external EERPOM, you can use restore command

Command: {Head1} {Types} {Lens} {Address} {Data} {CRC}

Head1 : 0x7E 0x00

Types : 0x09

Lens : 0x01

Address : 0x0000

Data : 0xFF

CRC : CRC_CCITT checksum

Return: {Head2} {Types} {Lens} {Data} {CRC}

1) Successfully save

Head2 : 0x02 0x00

Types : 0x00 (successfully save)
Lens : 0x01
Data : 0x00
CRC : CRC_CCITT checksum (0x33 0x31)

2) CRC check failed

No return

3) Unknow command

No return

ERASE

If you want to erase the programs on device, you can use erase command to erase bootloader or user program.

Command: {Head1} {Types} {Lens} { NotUse } {Data} {CRC}

Head1 : 0x7E 0x00 (2 bytes)

Types : 0x05 (1 byte)

Lens : 0x01 (1 byte) number of bytes of Data segment, also the num of write operation, 0x00 stand for 256 bytes

NotUse : 0x0000 (2 bytes) , tow 0x00

Data : 0x11/0x22/0x33 (1 bytes) , The data written; 0x11 stand for bootloader erase; 0x22 stand for user program erase, 0x33 is used to erase bootloader and user program (**for user, could only use 0x22, never use others**)

CRC : CRC_CCITT checksum (2 bytes). The calculate range: Types, Lens, Address, Data; Use CRC_CCITT polynomial: $X^{16}+X^{12}+X^5+1$, whose coefficients is 0x1021. Initial value is 0, first calculate high bit for single byte without negating.

```
unsigned int crc_cal_by_bit(unsigned char* ptr, unsigned int len)
{
    unsigned int crc = 0;
    while(len-- != 0)
    {
        for(unsigned char i = 0x80; i != 0; i /= 2)
        {
            crc *= 2;
            if((crc&0x10000) != 0) //上一位 CRC 乘 2 后, 若首位是 1, 则除以 0x11021
                crc ^= 0x11021;
        }
    }
}
```

Note: If you don't need CRC, you can replace it as 0xAB 0CD

Return: {Head2}{Types} {Lens} {Data} {CRC}

1) Erase successfully

Head2 : 0x02 0x00

Types : 0x00 (Erase successfully)

Lens : 0x01

Data : 0x00

CRC : CRC_CCITT checksum (0x33 0x31)

2) CRC failed

No return

3) Unknow command

No return

Examples:

Erase user program, device will enter bootloader mode and waiting for new program if user program is erased

1) Erase successfully

Command: 0x7E 0x00 0x05 0x01 0x00 0x00 0x22 xx xx

Return: 0x02 0x00 0x00 0x01 0x00 0x33 0x31

2) CRC failed

Command: 0x7E 0x00 0x05 0x01 0x00 0x00 0x22 xx xx

Return: None

3) The length of command is not enough or it is timeout after 0x7E 0x00 command

sent, it will be handled as unknow command

Command: 0x7E 0x00 0x05 0x01 0x00 0x00 0x22

Return: None

ADDRESS TABLE

Address	<i>0x0000</i>
Data bit	Function
Bit 7	1: Open LED indication for decoding successfully 0: Close LED indication
Bit 6	1: Close silence 0: Enable silence
Bit 5-4	00: No target 01: Standard 10/11: Keep lighting
Bit 3-2	00: No lighting 01: Standard 10/11: Keep lighting
Bit 1-0	00: Manual mode; 01: Command mode; 10: Continuous mode; 11: Sensing mode
Address	<i>0x0002</i>
Data bit	Function
Bit 7	Reserved
Bit 6	1: Output decoding states prompt 0: Without decoding states prompt
Bit 5-1	Reserved
Bit 1-0	Reserved
Address	<i>0x0003</i>
Data bit	Function
Bit 7-2	Reserved
Bit 1	1: Close Setting code 0: Open Setting code
Bit 1-0	1: Output content of Setting code 0: Without content of Setting code
Address	<i>0x0004</i>
Data bit	Function
Bit 7-0	Time of image stabilization
Address	<i>0x0005</i>
Data bit	Function
Bit 7-0	Interval of scanning
Address	<i>0x0006</i>
Data bit	Function

Bit 7-0	Time of single scanning
Address	<i>0x0007</i>
Data bit	Function
Bit 7	Auto-Sleep Function
Bit6-0	Idle time (Bit14-8)
Address	<i>0x0008</i>
Data bit	Function
Bit 7-0	Idle time (Bit7-0)
Address	<i>0x000A</i>
Data bit	Function
Bit 7-0	Frequency of warning tone
Address	<i>0x000B</i>
Data bit	Function
Bit 7-0	Duration of warning tone
Address	<i>0x000C</i>
Data bit	Function
Bit 7-1	Reserved
Bit0	Default level in active buzzer mode
Address	<i>0x000D</i>
Data bit	Function
Bit 7-4	Reserved
Bit 3-2	Data coding format
Bit1-0	00: UART 01: USB PC keyboard 10: Reserved 11: USB virtual port
Address	<i>0x000E</i>
Data bit	Function
Bit 7-3	Reserved
Bit2	1: Open warning tone of decoding 0: Close warning tone of decoding

Bit1-0	Reserved
Address	<i>0x002B, 0x2A</i>
Data bit	Function
Bit 15-13	Reserved
Bit 12-0	0x09C4: baud rate is 1200 bps
Address	<i>0x002C</i>
Data bit	Function
Bit 7-3	Reserved
Bit 2-1	Switch of all barcodes
Bit 0	Enable 360° rotation function
Address	<i>0x002E</i>
Data bit	Function
Bit 7-1	Reserved
Bit0	Enable EAN13
Address	<i>0x002F</i>
Data bit	Function
Bit 7-1	Reserved
Bit0	Enable EAN8
Address	<i>0x0030</i>
Data bit	Function
Bit 7-1	Reserved
Bit0	Enable UPCA
Address	<i>0x0031</i>
Data bit	Function
Bit 7-1	Reserved
Bit0	Enable UPCE0
Address	<i>0x0032</i>

Data bit	Function
Bit 7-1	Reserved
Bit0	Enable UPCE1
Address	<i>0x0033</i>
Data bit	Function
Bit 7-1	Reserved
Bit0	Enable Code128
Address	<i>0x0034</i>
Data bit	Function
Bit 7-0	Setting Code128 Min Length
Address	<i>0x0035</i>
Data bit	Function
Bit 7-0	Code128 Max Length setting
Address	<i>0x0036</i>
Data bit	Function
Bit 7-1	Reserved
Bit0	Enable Code39
Address	<i>0x0037</i>
Data bit	Function
Bit 7-0	Code39 Min Length setting
Address	<i>0x0038</i>
Data bit	Function
Bit 7-0	Code39 Max Length setting
Address	<i>0x0039</i>
Data bit	Function
Bit 7-1	Reserved
Bit0	Enable Code93

Address	<i>0x003A</i>
Data bit	Function
Bit 7-0	Code93 Min Length setting
Address	<i>0x003B</i>
Data bit	Function
Bit 7-0	Code93 Max Length setting
Address	<i>0x003C</i>
Data bit	Function
Bit 7-2	Reserved
Bit1	CodeBar send Start/Stop character
Bit0	Enable CodeBar
Address	<i>0x003D</i>
Data bit	Function
Bit 7-0	CodeBar Min Length setting
Address	<i>0x003E</i>
Data bit	Function
Bit 7-0	CodeBar Max Length setting
Address	<i>0x003F</i>
Data bit	Function
Bit 7-1	Reserved
Bit0	Enable QR code
Address	<i>0x0040</i>
Data bit	Function
Bit 7-1	Reserved
Bit0	Enable Interleaved 2 of 5
Address	<i>0x0041</i>
Data bit	Function

Bit 7-0	Interleaved 2 of 5 Min Length setting
Address	<i>0x0042</i>
Data bit	Function
Bit 7-0	Interleaved 2 of 5 Max Length setting
Address	<i>0x0043</i>
Data bit	Function
Bit 7-1	Reserved
Bit0	Enable Industrial 25
Address	<i>0x0044</i>
Data bit	Function
Bit 7-0	Industrial 25 Min Length setting
Address	<i>0x0045</i>
Data bit	Function
Bit 7-0	Industrial 25 Max Length setting
Address	<i>0x0046</i>
Data bit	Function
Bit 7-1	Reserved
Bit0	Enable Matrix 2 of 5
Address	<i>0x0047</i>
Data bit	Function
Bit 7-0	Matrix 2 of 5 Min Length setting
Address	<i>0x0048</i>
Data bit	Function
Bit 7-0	Matrix 2 of 5 Max Length setting
Address	<i>0x0049</i>
Data bit	Function
Bit 7-1	Reserved

Bit0	Enable Code11
Address	<i>0x004A</i>
Data bit	Function
Bit 7-0	Code11 Min Length setting
Address	<i>0x004B</i>
Data bit	Function
Bit 7-0	Code11 Max Length setting
Address	<i>0x004C</i>
Data bit	Function
Bit 7-1	Reserved
Bit0	Enable MSI
Address	<i>0x004D</i>
Data bit	Function
Bit 7-0	MSI Min Length setting
Address	<i>0x004E</i>
Data bit	Function
Bit 7-0	MSI Max Length setting
Address	<i>0x004F</i>
Data bit	Function
Bit 7-1	Reserved
Bit0	Enable RSS-14
Address	<i>0x0050</i>
Data bit	Function
Bit 7-1	Reserved
Bit0	Enable Limited RSS
Address	<i>0x0051</i>
Data bit	Function

Bit 7-1	Reserved
Bit0	Enable Expanded RSS
Address	<i>0x0052</i>
Data bit	Function
Bit 7-0	RSS Min Length setting
Address	<i>0x0053</i>
Data bit	Function
Bit 7-0	RSS Max Length setting
Address	<i>0x0054</i>
Data bit	Function
Bit 7-1	Reserved
Bit0	Enable DM
Address	<i>0x0055</i>
Data bit	Function
Bit 7-1	Reserved
Bit0	Enable PDF417
Address	<i>0x0060</i>
Data bit	Function
Bit 7	Reserved
Bit6-5	Type of End character Suffix
Bit4	1.Allow Adding RF 0: Without RF
Bit3	1: Allow Adding Prefix 0: Without Prefix
Bit2	1: Allow Adding Code ID 0: Without Code ID
Bit1	1: Allow Adding Suffix 0: Without Suffix
Bit0	1: Allow Adding End character 0: Without End character
Address	<i>0x0061</i>
Data bit	Function

Bit 7-0	Keyboard Setting
Address	<i>0x0062</i>
Data bit	Function
Bit 7-4	Prefix Length
Bit3-0	Suffix Length
Address	<i>0x0063 – 0x0071</i>
Data bit	Function
Bit 7-0	Prefix
Address	<i>0x0072 - 0x0080</i>
Data bit	Function
Bit 7-0	Suffix
Address	<i>0x0081</i>
Data bit	Function
Bit 7-4	Reserved
Bit3-0	RF Length
Address	<i>0x0082– 0x0081</i>
Data bit	Function
Bit 7-0	RF
Address	<i>0x0091 – 0x00A4</i>
Data bit	Function
Bit 7-0	Code ID setting
Address	<i>0x00B0</i>
Data bit	Function
Bit 7-2	Reserved
Bit 1-0	Data intercept setting
Address	<i>0x00B1</i>
Data bit	Function

Bit 7-0	Length of interception M (front)
Address	<i>0x00B2</i>
Data bit	Function
Bit 7-0	Length of interception N (End)
Address	<i>0x00D9 (Write-only Address)</i>
Data bit	Function
Bit 7-0	Function Address
Address	<i>0x00E0 (Read-only Address)</i>
Data bit	Function
Bit 7-0	Type of product
Address	<i>0x00E1 (Read-only Address)</i>
Data bit	Function
Bit 7-0	Hardware version
Address	<i>0x00E2 (Read-only Address)</i>
Data bit	Function
Bit 7-0	Software version
Address	<i>0x00E3 (Read-only Address)</i>
Data bit	Function
Bit 7-0	Year of software (Add 2000 stand for year)
Address	<i>0x00E4 (Read-only Address)</i>
Data bit	Function
Bit 7-0	Month of software
Address	<i>0x00E5 (Read-only Address)</i>
Data bit	Function
Bit 7-0	Date of software