

GigaDevice Semiconductor Inc.

GD32F107xx

Arm[®] Cortex[®]-M3 32-bit MCU

Datasheet



Table of Contents

Table of Contents	1
List of Figures	4
List of Tables	5
1. General description	7
2. Device overview	8
2.1. Device information	8
2.2. Block diagram.....	11
2.3. Pinouts and pin assignment	12
2.4. Memory map	15
2.5. Clock tree	19
2.6. Pin definitions.....	20
2.6.1. GD32F107Zx LQFP144 pin definitions.....	20
2.6.2. GD32F107Vx LQFP100 pin definitions	29
2.6.3. GD32F107Rx LQFP64 pin definitions	36
3. Functional description	41
3.1. Arm® Cortex®-M3 core	41
3.2. On-chip memory	41
3.3. Clock, reset and supply management.....	42
3.4. Boot modes.....	42
3.5. Power saving modes	43
3.6. Analog to digital converter (ADC)	43
3.7. Digital to analog converter (DAC).....	44
3.8. DMA	44
3.9. General-purpose inputs/outputs (GPIOs)	44
3.10. Timers and PWM generation	45
3.11. Real time clock (RTC)	46
3.12. Inter-integrated circuit (I2C)	46
3.13. Serial peripheral interface (SPI)	47
3.14. Universal synchronous asynchronous receiver transmitter (USART)	47
3.15. Inter-IC sound (I2S)	47



3.16.	Universal serial bus full-speed (USBFS)	48
3.17.	Controller area network (CAN)	48
3.18.	Ethernet MAC interface.....	48
3.19.	External memory controller (EXMC)	48
3.20.	Debug mode	49
3.21.	Package and operation temperature.....	49
4.	Electrical characteristics.....	50
4.1.	Absolute maximum ratings.....	50
4.2.	Operating conditions characteristics.....	50
4.3.	Power consumption	52
4.4.	EMC characteristics	56
4.5.	Power supply supervisor characteristics	56
4.6.	Electrical sensitivity	57
4.7.	External clock characteristics	58
4.8.	Internal clock characteristics	60
4.9.	PLL characteristics.....	60
4.10.	Memory characteristics	61
4.11.	NRST pin characteristics	62
4.12.	GPIO characteristics	62
4.13.	Temperature sensor characteristics	64
4.14.	ADC characteristics	64
4.15.	DAC characteristics	65
4.16.	I2C characteristics	66
4.17.	SPI characteristics	67
4.18.	I2S characteristics.....	69
4.19.	USART characteristics.....	71
4.20.	CAN characteristics	71
4.21.	USBFS characteristics.....	71
4.22.	EXMC characteristics.....	72
4.23.	TIMER characteristics.....	74
4.24.	WDGT characteristics	74



4.25. Parameter condition.....	75
5. Package information.....	76
5.1. LQFP144 package outline dimensions.....	76
5.2. LQFP100 package outline dimensions.....	78
5.3. LQFP64 package outline dimensions.....	80
5.4. Thermal characteristics	82
6. Ordering information	84
7. Revision history	85



List of Figures

Figure 2-1. GD32F107xx block diagram	11
Figure 2-2. GD32F107Zx LQFP144 pinouts	12
Figure 2-3. GD32F107Vx LQFP100 pinouts	13
Figure 2-4. GD32F107Rx LQFP64 pinouts	14
Figure 2-5. GD32F107xx clock tree	19
Figure 4-1. Recommended power supply decoupling capacitors ⁽¹⁾⁽²⁾	50
Figure 4-2. Typical supply current consumption in Run mode	55
Figure 4-3. Typical supply current consumption in Sleep mode	56
Figure 4-4. Recommended external NRST pin circuit ⁽¹⁾	62
Figure 4-5. I2C bus timing diagram	67
Figure 4-6. SPI timing diagram - master mode	68
Figure 4-7. SPI timing diagram - slave mode	69
Figure 4-8. I2S timing diagram - master mode	70
Figure 4-9. I2S timing diagram - slave mode	71
Figure 4-10. USBFS timings: definition of data signal rise and fall time	72
Figure 5-1. LQFP144 package outline	76
Figure 5-2. LQFP144 recommended footprint	77
Figure 5-3. LQFP100 package outline	78
Figure 5-4. LQFP100 recommended footprint	79
Figure 5-5. LQFP64 package outline	80
Figure 5-6. LQFP64 recommended footprint	81



List of Tables

Table 2-1. GD32F107xx devices features and peripheral list	8
Table 2-2. GD32F107xx devices features and peripheral list (continued)	10
Table 2-3. GD32F107xx memory map	15
Table 2-4. GD32F107Zx LQFP144 pin definitions	20
Table 2-5. GD32F107Vx LQFP100 pin definitions	29
Table 2-6. GD32F107Rx LQFP64 pin definitions	36
Table 4-1. Absolute maximum ratings ⁽¹⁾⁽⁴⁾	50
Table 4-2. DC operating conditions	50
Table 4-3. Clock frequency ⁽¹⁾	51
Table 4-4. Operating conditions at Power up/ Power down ⁽¹⁾	51
Table 4-5. Start-up timings of Operating conditions ⁽¹⁾⁽²⁾⁽³⁾	51
Table 4-6. Power saving mode wakeup timings characteristics ⁽¹⁾⁽²⁾	52
Table 4-7. Power consumption characteristics ⁽²⁾⁽³⁾⁽⁴⁾⁽⁵⁾	52
Table 4-8. EMS characteristics ⁽¹⁾	56
Table 4-9. Power supply supervisor characteristics	56
Table 4-10. ESD characteristics ⁽¹⁾	57
Table 4-11. Static latch-up characteristics ⁽¹⁾	58
Table 4-12. High speed external clock (HXTAL) generated from a crystal/ceramic characteristics	58
Table 4-13. High speed external clock characteristics (HXTAL in bypass mode)	58
Table 4-14. Low speed external clock (LXTAL) generated from a crystal/ceramic characteristics	59
Table 4-15. Low speed external user clock characteristics (LXTAL in bypass mode)	59
Table 4-16. High speed internal clock (IRC8M) characteristics	60
Table 4-17. Low speed internal clock (IRC40K) characteristics	60
Table 4-18. PLL characteristics	60
Table 4-19. PLL1 characteristics	61
Table 4-20. PLL2 characteristics	61
Table 4-21. Flash memory characteristics	61
Table 4-22. NRST pin characteristics	62
Table 4-23. I/O port DC characteristics ⁽¹⁾⁽³⁾	62
Table 4-24. I/O port AC characteristics ⁽¹⁾⁽²⁾⁽⁴⁾	64
Table 4-25. Temperature sensor characteristics ⁽¹⁾	64
Table 4-26. ADC characteristics	64
Table 4-27. ADC $R_{AIN\ max}$ for $f_{ADC} = 14\ MHz$	65
Table 4-28. DAC characteristics	65
Table 4-29. I2C characteristics ⁽¹⁾⁽²⁾⁽³⁾	66
Table 4-30. Standard SPI characteristics ⁽¹⁾	67
Table 4-31. I2S characteristics ⁽¹⁾⁽²⁾	69
Table 4-32. USART characteristics ⁽¹⁾	71
Table 4-33. USBFS start up time	71
Table 4-34. USBFS DC electrical characteristics	72



Table 4-35. USBFS full speed-electrical characteristics ⁽¹⁾	72
Table 4-36. Synchronous multiplexed PSRAM/NOR read timings ⁽¹⁾⁽²⁾⁽³⁾	72
Table 4-37. Synchronous multiplexed PSRAM write timings ⁽¹⁾⁽²⁾⁽³⁾	73
Table 4-38. Synchronous non-multiplexed PSRAM/NOR read timings ⁽¹⁾⁽²⁾⁽³⁾	73
Table 4-39. Synchronous non-multiplexed PSRAM write timings ⁽¹⁾⁽²⁾⁽³⁾	74
Table 4-40. TIMER characteristics ⁽¹⁾	74
Table 4-41. FWDGT min/max timeout period at 40 kHz (IRC40K) ⁽¹⁾	74
Table 4-42. WWDGT min-max timeout value at 54 MHz (f _{PCLK1}) ⁽¹⁾	75
Table 5-1. LQFP144 package dimensions.....	76
Table 5-2. LQFP100 package dimensions.....	78
Table 5-3. LQFP64 package dimensions.....	80
Table 5-4. Package thermal characteristics ⁽¹⁾	82
Table 6-1. Part ordering code for GD32F107xx devices.....	84
Table 7-1. Revision history.....	85

1. General description

The GD32F107xx device belongs to the connectivity line of GD32 MCU Family. It is a 32-bit general-purpose microcontroller based on the Arm® Cortex®-M3 RISC core with enhanced connectivity performance and best ratio in terms of processing power, reduced power consumption and peripheral set. The Cortex®-M3 is a next generation processor core which is tightly coupled with a Nested Vectored Interrupt Controller (NVIC), SysTick timer and advanced debug support.

The GD32F107xx device incorporates the Arm® Cortex®-M3 32-bit processor core operating at 108 MHz frequency with Flash accesses zero wait states to obtain maximum efficiency. It provides up to 1 MB on-chip Flash memory and 96 KB SRAM memory. An extensive range of enhanced I/Os and peripherals connected to two APB buses. The devices offer up to two 12-bit ADCs, up to two 12-bit DACs, up to four general-purpose 16-bit timers, two basic timers plus one PWM advanced-control timer, as well as standard and advanced communication interfaces: up to three SPIs, two I²Cs, three USARTs, two UARTs, two I²Ss, two CANs, an USBFS and an Ethernet MAC.

The device operates from a 2.6 to 3.6 V power supply and available in –40 to +85 °C temperature range. Several power saving modes provide the flexibility for maximum optimization between wakeup latency and power consumption, an especially important consideration in low power applications.

The above features make the GD32F107xx devices suitable for a wide range of interconnection applications, especially in areas such as industrial control, motor drives, power monitor and alarm systems, consumer and handheld equipment, POS, vehicle GPS, LED display and so on.

2. Device overview

2.1. Device information

Table 2-1. GD32F107xx devices features and peripheral list

Part Number		GD32F107xx							
		RB	RC	RD	RE	RF	RG	VB	VC
Flash	Code Area (KB)	128	256	256	256	256	256	128	256
	Data Area (KB)	0	0	128	256	512	768	0	0
	Total (KB)	128	256	384	512	768	1024	128	256
SRAM (KB)		96	96	96	96	96	96	96	96
Timers	GPTM(16 bit)	4 <small>(1-4)</small>	4 <small>(1-4)</small>	4 <small>(1-4)</small>	4 <small>(1-4)</small>	4 <small>(1-4)</small>	4 <small>(1-4)</small>	4 <small>(1-4)</small>	4 <small>(1-4)</small>
	Advanced TM(16 bit)	1 <small>(0)</small>	1 <small>(0)</small>	1 <small>(0)</small>	1 <small>(0)</small>	1 <small>(0)</small>	1 <small>(0)</small>	1 <small>(0)</small>	1 <small>(0)</small>
	SysTick	1	1	1	1	1	1	1	1
	Basic TM(16 bit)	2 <small>(5-6)</small>	2 <small>(5-6)</small>	2 <small>(5-6)</small>	2 <small>(5-6)</small>	2 <small>(5-6)</small>	2 <small>(5-6)</small>	2 <small>(5-6)</small>	2 <small>(5-6)</small>
	Watchdog	2	2	2	2	2	2	2	2
	RTC	1	1	1	1	1	1	1	1
Connectivity	U(S)ART	5	5	5	5	5	5	5	5
	I2C	1 <small>(0)</small>	1 <small>(0)</small>	2 <small>(0-1)</small>	2 <small>(0-1)</small>	2 <small>(0-1)</small>	2 <small>(0-1)</small>	1 <small>(0)</small>	1 <small>(0)</small>
	SPI	3 <small>(0-2)</small>	3 <small>(0-2)</small>	3 <small>(0-2)</small>	3 <small>(0-2)</small>	3 <small>(0-2)</small>	3 <small>(0-2)</small>	3 <small>(0-2)</small>	3 <small>(0-2)</small>
	I2S	2 <small>(1-2)</small>	2 <small>(1-2)</small>	2 <small>(1-2)</small>	2 <small>(1-2)</small>	2 <small>(1-2)</small>	2 <small>(1-2)</small>	2 <small>(1-2)</small>	2 <small>(1-2)</small>
	CAN 2.0B	2	2	2	2	2	2	2	2
	USBFS	1	1	1	1	1	1	1	1
	Ethernet MAC	1	1	1	1	1	1	1	1
GPIO		51	51	51	51	51	51	80	80
EXMC		0	0	0	0	0	0	1	1
EXTI		16	16	16	16	16	16	16	16



Part Number		GD32F107xx							
		RB	RC	RD	RE	RF	RG	VB	VC
ADC	Units	2	2	2	2	2	2	2	2
	Channels	16	16	16	16	16	16	16	16
DAC		2	2	2	2	2	2	2	2
Package		LQFP64						LQFP100	

Table 2-2. GD32F107xx devices features and peripheral list (continued)

Part Number		GD32F107xx								
		VD	VE	VF	VG	ZC	ZD	ZE	ZF	ZG
Flash	Code Area (KB)	256	256	256	256	256	256	256	256	256
	Data Area (KB)	128	256	512	768	0	128	256	512	768
	Total (KB)	384	512	768	1024	256	384	512	768	1024
SRAM (KB)		96	96	96	96	96	96	96	96	96
Timers	GPTM(16 bit)	4 <small>(1-4)</small>	4 <small>(1-4)</small>	4 <small>(1-4)</small>	4 <small>(1-4)</small>	4 <small>(1-4)</small>	4 <small>(1-4)</small>	4 <small>(1-4)</small>	4 <small>(1-4)</small>	4 <small>(1-4)</small>
	Advanced TM(16 bit)	1 <small>(0)</small>	1 <small>(0)</small>	1 <small>(0)</small>	1 <small>(0)</small>	1 <small>(0)</small>	1 <small>(0)</small>	1 <small>(0)</small>	1 <small>(0)</small>	1 <small>(0)</small>
	SysTick	1	1	1	1	1	1	1	1	1
	Basic TM(16 bit)	2 <small>(5-6)</small>	2 <small>(5-6)</small>	2 <small>(5-6)</small>	2 <small>(5-6)</small>	2 <small>(5-6)</small>	2 <small>(5-6)</small>	2 <small>(5-6)</small>	2 <small>(5-6)</small>	2 <small>(5-6)</small>
	Watchdog	2	2	2	2	2	2	2	2	2
	RTC	1	1	1	1	1	1	1	1	1
Connectivity	U(S)ART	5	5	5	5	5	5	5	5	5
	I2C	2	2	2	2	2	2	2	2	2
	SPI	3 <small>(0-2)</small>	3 <small>(0-2)</small>	3 <small>(0-2)</small>	3 <small>(0-2)</small>	3 <small>(0-2)</small>	3 <small>(0-2)</small>	3 <small>(0-2)</small>	3 <small>(0-2)</small>	3 <small>(0-2)</small>
	I2S	2 <small>(1-2)</small>	2 <small>(1-2)</small>	2 <small>(1-2)</small>	2 <small>(1-2)</small>	2 <small>(1-2)</small>	2 <small>(1-2)</small>	2 <small>(1-2)</small>	2 <small>(1-2)</small>	2 <small>(1-2)</small>
	CAN 2.0B	2	2	2	2	2	2	2	2	2
	USBFS	1	1	1	1	1	1	1	1	1
	Ethernet MAC	1	1	1	1	1	1	1	1	1
GPIO		80	80	80	80	112	112	112	112	112
EXMC		1	1	1	1	1	1	1	1	1
EXTI		16	16	16	16	16	16	16	16	16
ADC	Units	2	2	2	2	2	2	2	2	2
	Channels	16	16	16	16	16	16	16	16	16
DAC		2	2	2	2	2	2	2	2	2
Package		LQFP100				LQFP144				

2.2. Block diagram

Figure 2-1. GD32F107xx block diagram

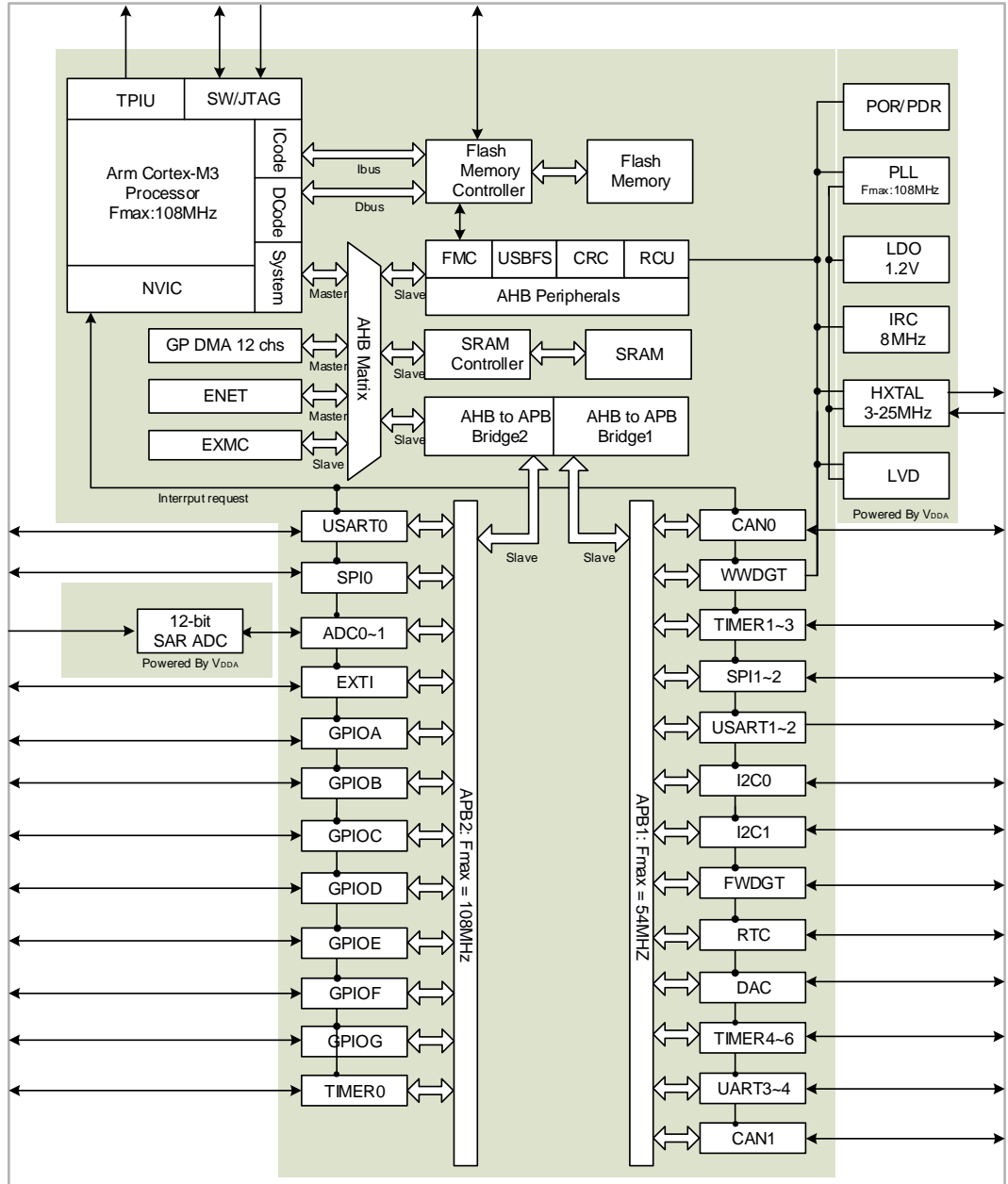

2.3. Pinouts and pin assignment

Figure 2-2. GD32F107Zx LQFP144 pinouts

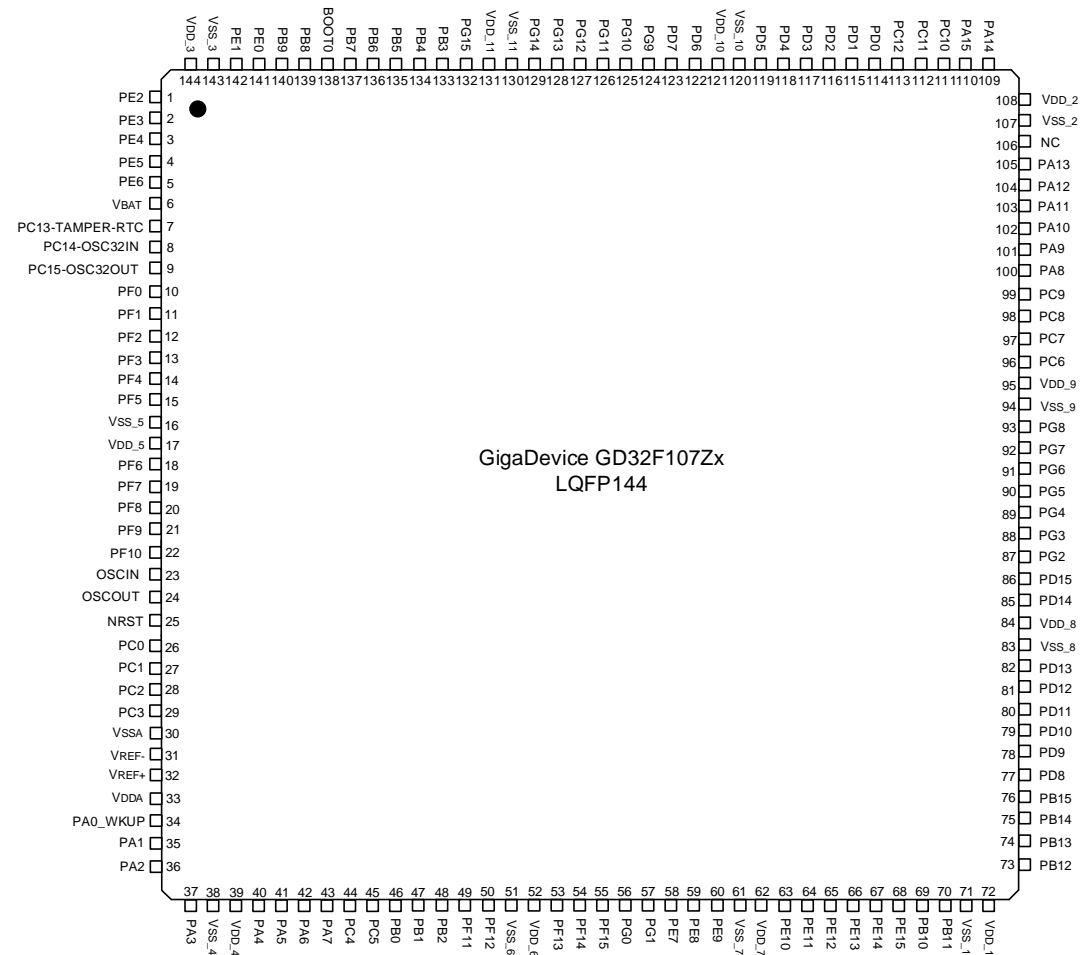

Figure 2-3. GD32F107Vx LQFP100 pinouts

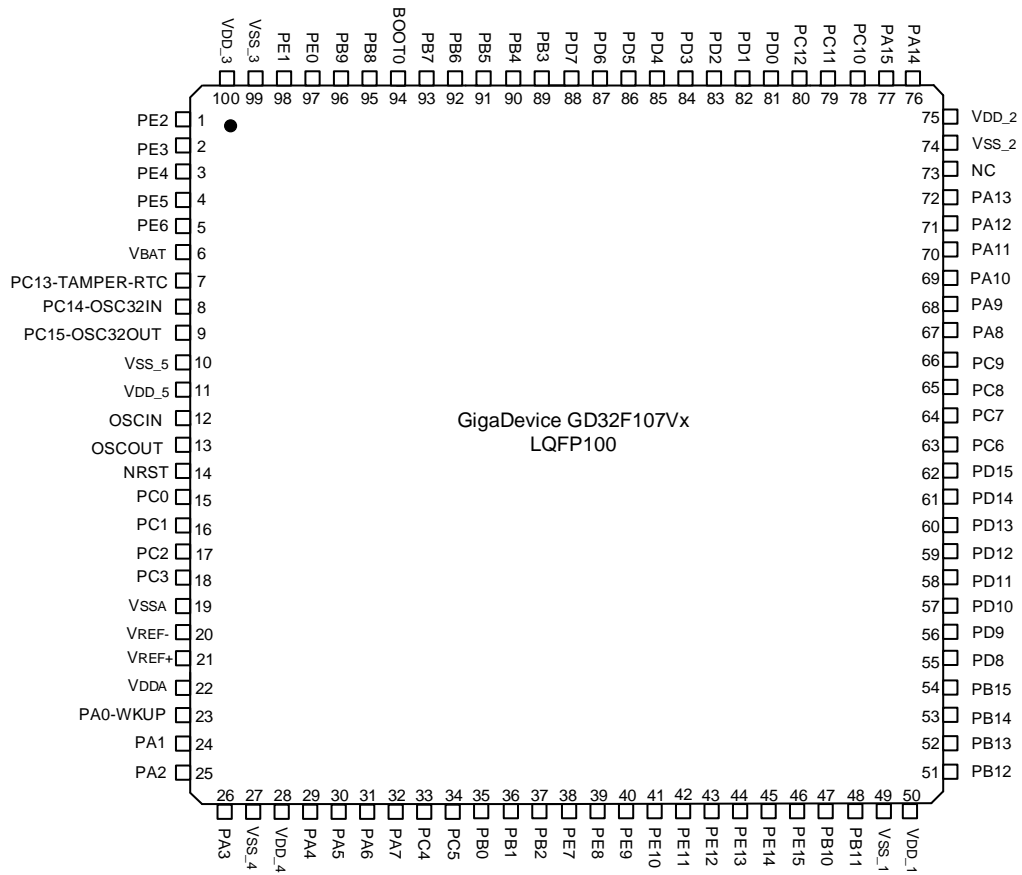
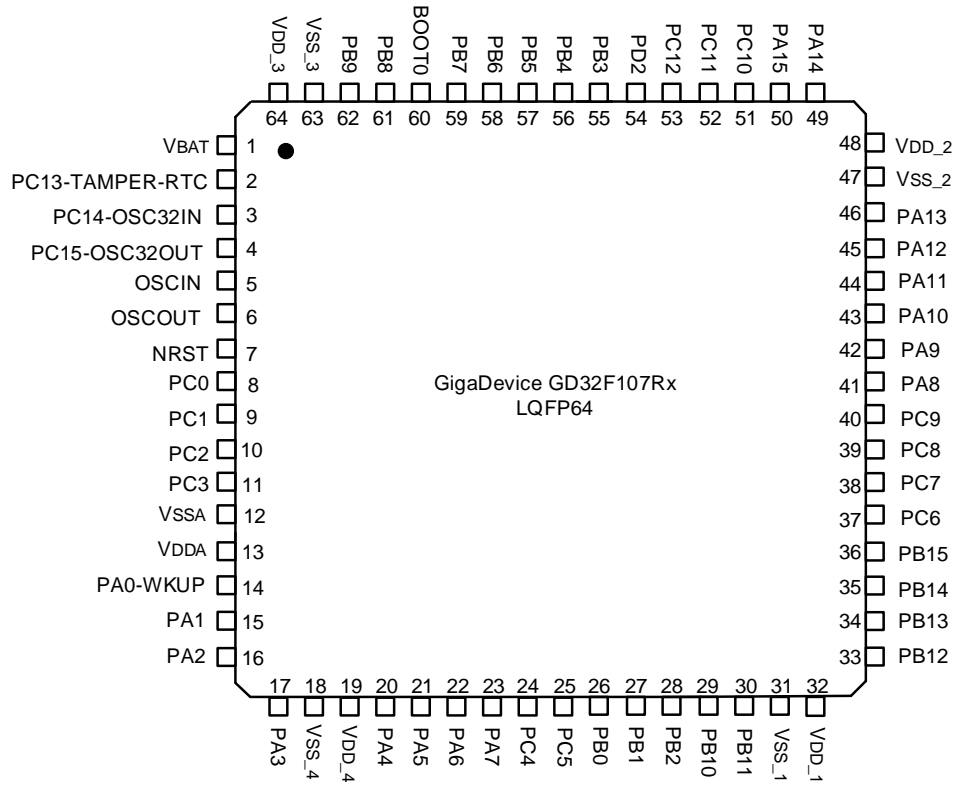

Figure 2-4. GD32F107Rx LQFP64 pinouts



2.4. Memory map

Table 2-3. GD32F107xx memory map

Pre-defined Regions	Bus	Address	Peripherals
External device	AHB	0xA000 0000 - 0xA000 0FFF	EXMC - SWREG
External RAM		0x9000 0000 - 0x9FFF FFFF	EXMC - PC CARD
		0x7000 0000 - 0x8FFF FFFF	EXMC - NAND
External RAM	AHB	0x6000 0000 - 0x6FFF FFFF	EXMC - NOR/PSRAM/SRAM
		Peripheral	AHB
Peripheral	AHB	0x4008 0000 - 0x4FFF FFFF	Reserved
		0x4004 0000 - 0x4007 FFFF	Reserved
		0x4002 BC00 - 0x4003 FFFF	Reserved
		0x4002 B000 - 0x4002 BBFF	Reserved
		0x4002 A000 - 0x4002 AFFF	Reserved
		0x4002 8000 - 0x4002 9FFF	ENET
		0x4002 6800 - 0x4002 7FFF	Reserved
		0x4002 6400 - 0x4002 67FF	Reserved
		0x4002 6000 - 0x4002 63FF	Reserved
		0x4002 5000 - 0x4002 5FFF	Reserved
		0x4002 4000 - 0x4002 4FFF	Reserved
		0x4002 3C00 - 0x4002 3FFF	Reserved
		0x4002 3800 - 0x4002 3BFF	Reserved
		0x4002 3400 - 0x4002 37FF	Reserved
		0x4002 3000 - 0x4002 33FF	CRC
		0x4002 2C00 - 0x4002 2FFF	Reserved
		0x4002 2800 - 0x4002 2BFF	Reserved
		0x4002 2400 - 0x4002 27FF	Reserved
		0x4002 2000 - 0x4002 23FF	FMC
		0x4002 1C00 - 0x4002 1FFF	Reserved
		0x4002 1800 - 0x4002 1BFF	Reserved
		0x4002 1400 - 0x4002 17FF	Reserved
		0x4002 1000 - 0x4002 13FF	RCU
		0x4002 0C00 - 0x4002 0FFF	Reserved
		0x4002 0800 - 0x4002 0BFF	Reserved
		0x4002 0400 - 0x4002 07FF	DMA1
		0x4002 0000 - 0x4002 03FF	DMA0
0x4001 8400 - 0x4001 FFFF	Reserved		



Pre-defined Regions	Bus	Address	Peripherals
		0x4001 8000 - 0x4001 83FF	Reserved
	APB2	0x4001 7C00 - 0x4001 7FFF	Reserved
		0x4001 7800 - 0x4001 7BFF	Reserved
		0x4001 7400 - 0x4001 77FF	Reserved
		0x4001 7000 - 0x4001 73FF	Reserved
		0x4001 6C00 - 0x4001 6FFF	Reserved
		0x4001 6800 - 0x4001 6BFF	Reserved
		0x4001 5C00 - 0x4001 67FF	Reserved
		0x4001 5800 - 0x4001 5BFF	Reserved
		0x4001 5400 - 0x4001 57FF	Reserved
		0x4001 5000 - 0x4001 53FF	Reserved
		0x4001 4C00 - 0x4001 4FFF	Reserved
		0x4001 4800 - 0x4001 4BFF	Reserved
		0x4001 4400 - 0x4001 47FF	Reserved
		0x4001 4000 - 0x4001 43FF	Reserved
		0x4001 3C00 - 0x4001 3FFF	Reserved
		0x4001 3800 - 0x4001 3BFF	USART0
		0x4001 3400 - 0x4001 37FF	Reserved
		0x4001 3000 - 0x4001 33FF	SPI0
		0x4001 2C00 - 0x4001 2FFF	TIMER0
		0x4001 2800 - 0x4001 2BFF	ADC1
		0x4001 2400 - 0x4001 27FF	ADC0
		0x4001 2000 - 0x4001 23FF	GPIOG
		0x4001 1C00 - 0x4001 1FFF	GPIOF
		0x4001 1800 - 0x4001 1BFF	GPIOE
		0x4001 1400 - 0x4001 17FF	GPIOD
		0x4001 1000 - 0x4001 13FF	GPIOC
		0x4001 0C00 - 0x4001 0FFF	GPIOB
		0x4001 0800 - 0x4001 0BFF	GPIOA
	0x4001 0400 - 0x4001 07FF	EXTI	
	0x4001 0000 - 0x4001 03FF	AFIO	
	APB1	0x4000 CC00 - 0x4000 FFFF	Reserved
		0x4000 C800 - 0x4000 CBFF	Reserved
		0x4000 C400 - 0x4000 C7FF	Reserved
		0x4000 C000 - 0x4000 C3FF	Reserved
		0x4000 8000 - 0x4000 BFFF	Reserved
0x4000 7C00 - 0x4000 7FFF		Reserved	
0x4000 7800 - 0x4000 7BFF		Reserved	
0x4000 7400 - 0x4000 77FF		DAC	
0x4000 7000 - 0x4000 73FF		PMU	



Pre-defined Regions	Bus	Address	Peripherals
		0x4000 6C00 - 0x4000 6FFF	BKP
		0x4000 6800 - 0x4000 6BFF	CAN1
		0x4000 6400 - 0x4000 67FF	CAN0
		0x4000 6000 - 0x4000 63FF	Shared CAN SRAM 512 bytes
		0x4000 5C00 - 0x4000 5FFF	Reserved
		0x4000 5800 - 0x4000 5BFF	I2C1
		0x4000 5400 - 0x4000 57FF	I2C0
		0x4000 5000 - 0x4000 53FF	UART4
		0x4000 4C00 - 0x4000 4FFF	UART3
		0x4000 4800 - 0x4000 4BFF	USART2
		0x4000 4400 - 0x4000 47FF	USART1
		0x4000 4000 - 0x4000 43FF	Reserved
		0x4000 3C00 - 0x4000 3FFF	SPI2/I2S2
		0x4000 3800 - 0x4000 3BFF	SPI1/I2S1
		0x4000 3400 - 0x4000 37FF	Reserved
		0x4000 3000 - 0x4000 33FF	FWDGT
		0x4000 2C00 - 0x4000 2FFF	WWDGT
		0x4000 2800 - 0x4000 2BFF	RTC
		0x4000 2400 - 0x4000 27FF	Reserved
		0x4000 2000 - 0x4000 23FF	Reserved
		0x4000 1C00 - 0x4000 1FFF	Reserved
		0x4000 1800 - 0x4000 1BFF	Reserved
		0x4000 1400 - 0x4000 17FF	TIMER6
		0x4000 1000 - 0x4000 13FF	TIMER5
		0x4000 0C00 - 0x4000 0FFF	TIMER4
		0x4000 0800 - 0x4000 0BFF	TIMER3
0x4000 0400 - 0x4000 07FF	TIMER2		
0x4000 0000 - 0x4000 03FF	TIMER1		
SRAM	AHB	0x2007 0000 - 0x3FFF FFFF	Reserved
		0x2006 0000 - 0x2006 FFFF	Reserved
		0x2003 0000 - 0x2005 FFFF	Reserved
		0x2002 0000 - 0x2002 FFFF	Reserved
		0x2001 C000 - 0x2001 FFFF	Reserved
		0x2001 8000 - 0x2001 BFFF	Reserved
		0x2000 5000 - 0x2001 7FFF	SRAM
		0x2000 0000 - 0x2000 4FFF	
Code	AHB	0x1FFF F810 - 0x1FFF FFFF	Reserved
		0x1FFF F800 - 0x1FFF F80F	Option Bytes
		0x1FFF B000 - 0x1FFF F7FF	Boot loader



Pre-defined Regions	Bus	Address	Peripherals
		0x1FFF 7A10 - 0x1FFF AFFF	Reserved
		0x1FFF 7800 - 0x1FFF 7A0F	Reserved
		0x1FFF 0000 - 0x1FFF 77FF	Reserved
		0x1FFE C010 - 0x1FFE FFFF	Reserved
		0x1FFE C000 - 0x1FFE C00F	Reserved
		0x1001 0000 - 0x1FFE BFFF	Reserved
		0x1000 0000 - 0x1000 FFFF	Reserved
		0x083C 0000 - 0x0FFF FFFF	Reserved
		0x0830 0000 - 0x083B FFFF	Reserved
		0x0810 0000 - 0x082F FFFF	Main Flash
		0x0802 0000 - 0x080F FFFF	
		0x0800 0000 - 0x0801 FFFF	
		0x0030 0000 - 0x07FF FFFF	Reserved
		0x0010 0000 - 0x002F FFFF	Aliased to Main Flash or Boot loader
		0x0002 0000 - 0x000F FFFF	
		0x0000 0000 - 0x0001 FFFF	

2.5. Clock tree

Figure 2-5. GD32F107xx clock tree

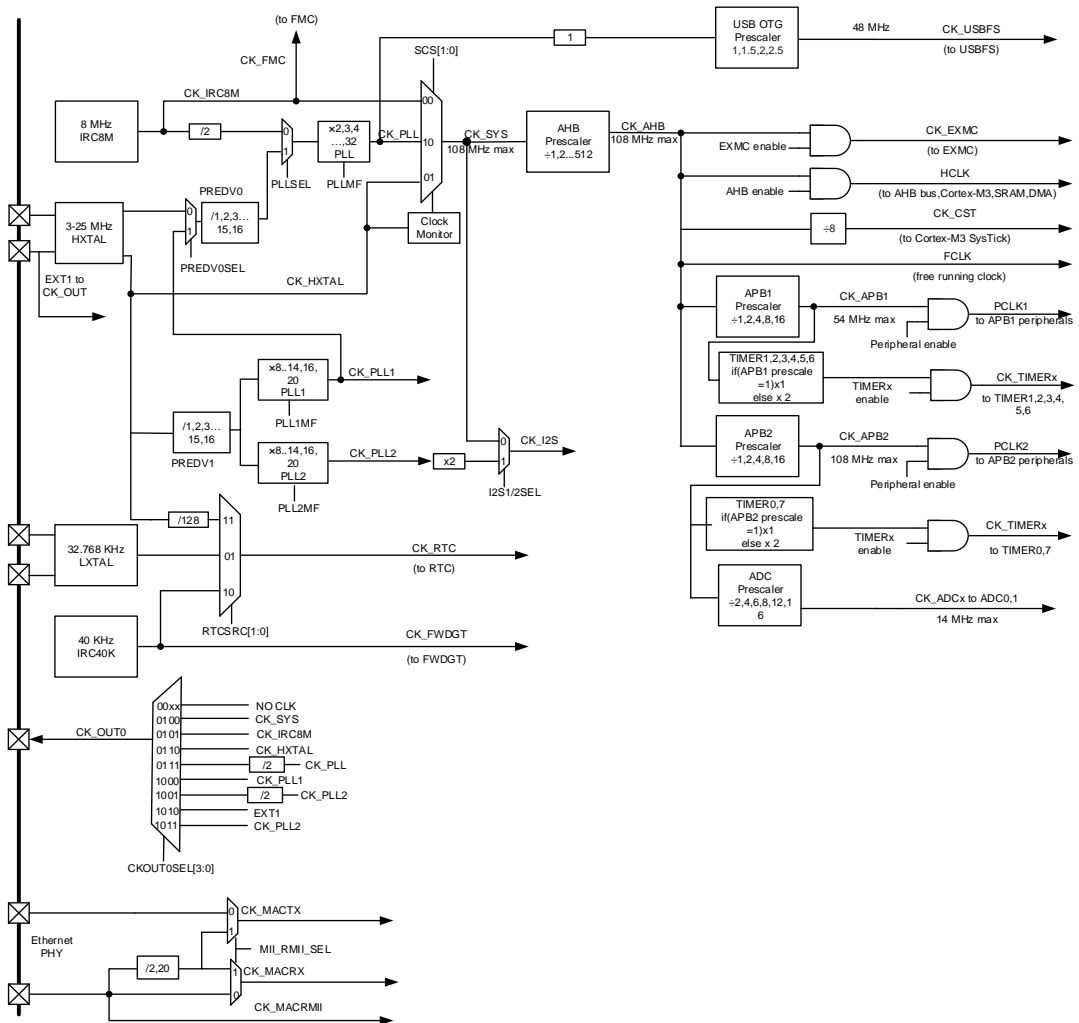

Legend:

- HXTAL: High speed external clock
- LXTAL: Low speed external clock
- IRC8M: High speed internal clock
- IRC40K: Low speed internal clock



2.6. Pin definitions

2.6.1. GD32F107Zx LQFP144 pin definitions

Table 2-4. GD32F107Zx LQFP144 pin definitions

Pin Name	Pins	Pin Type ⁽¹⁾	I/O Level ⁽²⁾	Functions description
PE2	1	I/O	5VT	Default: PE2 Alternate: TRACECK, EXMC_A23
PE3	2	I/O	5VT	Default: PE3 Alternate: TRACED0, EXMC_A19
PE4	3	I/O	5VT	Default: PE4 Alternate:TRACED1, EXMC_A20
PE5	4	I/O	5VT	Default: PE5 Alternate:TRACED2, EXMC_A21
PE6	5	I/O	5VT	Default: PE6 Alternate:TRACED3, EXMC_A22
V _{BAT}	6	P		Default: V _{BAT}
PC13- TAMPER- RTC	7	I/O		Default: PC13 Alternate: TAMPER-RTC
PC14- OSC32IN	8	I/O		Default: PC14 Alternate: OSC32IN
PC15- OSC32OUT	9	I/O		Default: PC15 Alternate: OSC32OUT
PF0	10	I/O	5VT	Default: PF0 Alternate: EXMC_A0
PF1	11	I/O	5VT	Default: PF1 Alternate: EXMC_A1
PF2	12	I/O	5VT	Default: PF2 Alternate: EXMC_A2
PF3	13	I/O	5VT	Default: PF3 Alternate: EXMC_A3
PF4	14	I/O	5VT	Default: PF4 Alternate: EXMC_A4
PF5	15	I/O	5VT	Default: PF5 Alternate: EXMC_A5
V _{SS_5}	16	P		Default: V _{SS_5}
V _{DD_5}	17	P		Default: V _{DD_5}
PF6	18	I/O		Default: PF6



Pin Name	Pins	Pin Type ⁽¹⁾	I/O Level ⁽²⁾	Functions description
				Alternate: EXMC_NIORD
PF7	19	I/O		Default: PF7 Alternate: EXMC_NREG
PF8	20	I/O		Default: PF8 Alternate: EXMC_NIOWR
PF9	21	I/O		Default: PF9 Alternate: EXMC_CD
PF10	22	I/O		Default: PF10 Alternate: EXMC_INTR
OSCIN	23	I		Default: OSCIN Remap: PD0
OSCOUT	24	O		Default: OSCOUT Remap: PD1
NRST	25	I/O		Default: NRST
PC0	26	I/O		Default: PC0 Alternate: ADC01_IN10
PC1	27	I/O		Default: PC1 Alternate: ADC01_IN11, ETH_MII_MDC, ETH_RMII_MDC
PC2	28	I/O		Default: PC2 Alternate: ADC01_IN12, ETH_MII_TXD2
PC3	29	I/O		Default: PC3 Alternate: ADC01_IN13, ETH_MII_TX_CLK
V _{SSA}	30	P		Default: V _{SSA}
V _{REF-}	31	P		Default: V _{REF-}
V _{REF+}	32	P		Default: V _{REF+}
V _{DDA}	33	P		Default: V _{DDA}
PA0-WKUP	34	I/O		Default: PA0 Alternate: WKUP, USART1_CTS, ADC01_IN0, TIMER1_CH0, TIMER1_ETI, TIMER4_CH0, ETH_MII_CRS
PA1	35	I/O		Default: PA1 Alternate: USART1_RTS, ADC01_IN1, TIMER1_CH1, TIMER4_CH1, ETH_MII_RX_CLK, ETH_RMII_REF_CLK
PA2	36	I/O		Default: PA2 Alternate: USART1_TX, ADC01_IN2, TIMER1_CH2, TIMER4_CH2, ETH_MII_MDIO, ETH_RMII_MDIO



Pin Name	Pins	Pin Type ⁽¹⁾	I/O Level ⁽²⁾	Functions description
PA3	37	I/O		Default: PA3 Alternate: USART1_RX, ADC01_IN3, TIMER1_CH3, TIMER4_CH3, ETH_MII_COL
V _{SS_4}	38	P		Default: V _{SS_4}
V _{DD_4}	39	P		Default: V _{DD_4}
PA4	40	I/O		Default: PA4 Alternate: SPI0_NSS, USART1_CK, ADC01_IN4, DAC_OUT0 Remap: SPI2_NSS, I2S2_WS
PA5	41	I/O		Default: PA5 Alternate: SPI0_SCK, ADC01_IN5, DAC_OUT1
PA6	42	I/O		Default: PA6 Alternate: SPI0_MISO, ADC01_IN6, TIMER2_CH0 Remap: TIMER0_BKIN
PA7	43	I/O		Default: PA7 Alternate: SPI0_MOSI, ADC01_IN7, TIMER2_CH1, ETH_MII_RX_DV, ETH_RMII_CRS_DV Remap: TIMER0_CH0_ON
PC4	44	I/O		Default: PC4 Alternate: ADC01_IN14, ETH_MII_RXD0, ETH_RMII_RXD0
PC5	45	I/O		Default: PC5 Alternate: ADC01_IN15, ETH_MII_RXD1, ETH_RMII_RXD1
PB0	46	I/O		Default: PB0 Alternate: ADC01_IN8, TIMER2_CH2, ETH_MII_RXD2 Remap: TIMER0_CH1_ON
PB1	47	I/O		Default: PB1 Alternate: ADC01_IN9, TIMER2_CH3, ETH_MII_RXD3 Remap: TIMER0_CH2_ON
PB2	48	I/O	5VT	Default: PB2, BOOT1
PF11	49	I/O	5VT	Default: PF11 Alternate: EXMC_NIOS16
PF12	50	I/O	5VT	Default: PF12 Alternate: EXMC_A6



Pin Name	Pins	Pin Type ⁽¹⁾	I/O Level ⁽²⁾	Functions description
V _{SS_6}	51	P		Default: V _{SS_6}
V _{DD_6}	52	P		Default: V _{DD_6}
PF13	53	I/O	5VT	Default: PF13 Alternate: EXMC_A7
PF14	54	I/O	5VT	Default: PF14 Alternate: EXMC_A8
PF15	55	I/O	5VT	Default: PF15 Alternate: EXMC_A9
PG0	56	I/O	5VT	Default: PG0 Alternate: EXMC_A10
PG1	57	I/O	5VT	Default: PG1 Alternate: EXMC_A11
PE7	58	I/O	5VT	Default: PE7 Alternate: EXMC_D4 Remap: TIMER0_ETI
PE8	59	I/O	5VT	Default: PE8 Alternate: EXMC_D5 Remap: TIMER0_CH0_ON
PE9	60	I/O	5VT	Default: PE9 Alternate: EXMC_D6 Remap: TIMER0_CH0
V _{SS_7}	61	P		Default: V _{SS_7}
V _{DD_7}	62	P		Default: V _{DD_7}
PE10	63	I/O	5VT	Default: PE10 Alternate: EXMC_D7 Remap: TIMER0_CH1_ON
PE11	64	I/O	5VT	Default: PE11 Alternate: EXMC_D8 Remap: TIMER0_CH1
PE12	65	I/O	5VT	Default: PE12 Alternate: EXMC_D9 Remap: TIMER0_CH2_ON
PE13	66	I/O	5VT	Default: PE13 Alternate: EXMC_D10 Remap: TIMER0_CH2
PE14	67	I/O	5VT	Default: PE14 Alternate: EXMC_D11 Remap: TIMER0_CH3
PE15	68	I/O	5VT	Default: PE15



Pin Name	Pins	Pin Type ⁽¹⁾	I/O Level ⁽²⁾	Functions description
				Alternate: EXMC_D12 Remap: TIMER0_BKIN
PB10	69	I/O	5VT	Default: PB10 Alternate: I2C1_SCL, USART2_TX, ETH_MII_RX_ER Remap: TIMER1_CH2
PB11	70	I/O	5VT	Default: PB11 Alternate: I2C1_SDA, USART2_RX, ETH_MII_TX_EN, ETH_RMII_TX_EN Remap: TIMER1_CH3
V _{SS_1}	71	P		Default: V _{SS_1}
V _{DD_1}	72	P		Default: V _{DD_1}
PB12	73	I/O	5VT	Default: PB12 Alternate: SPI1_NSS, I2C1_SMBA, USART2_CK, TIMER0_BKIN, I2S1_WS, CAN1_RX, ETH_MII_TXD0, ETH_RMII_TXD0
PB13	74	I/O	5VT	Default: PB13 Alternate: SPI1_SCK, USART2_CTS, TIMER0_CH0_ON, I2S1_CK, CAN1_TX, ETH_MII_TXD1, ETH_RMII_TXD1
PB14	75	I/O	5VT	Default: PB14 Alternate: SPI1_MISO, USART2_RTS, TIMER0_CH1_ON
PB15	76	I/O	5VT	Default: PB15 Alternate: SPI1_MOSI, TIMER0_CH2_ON, I2S1_SD
PD8	77	I/O	5VT	Default: PD8 Alternate: EXMC_D13 Remap: USART2_TX, ETH_MII_RX_DV, ETH_RMII_CRS_DV
PD9	78	I/O	5VT	Default: PD9 Alternate: EXMC_D14 Remap: USART2_RX, ETH_MII_RXD0, ETH_RMII_RXD0
PD10	79	I/O	5VT	Default: PD10 Alternate: EXMC_D15 Remap: USART2_CK, ETH_MII_RXD1, ETH_RMII_RXD1
PD11	80	I/O	5VT	Default: PD11



Pin Name	Pins	Pin Type ⁽¹⁾	I/O Level ⁽²⁾	Functions description
				Alternate: EXMC_A16/EXMC_CLE Remap: USART2_CTS, ETH_MII_RXD2
PD12	81	I/O	5VT	Default: PD12 Alternate: EXMC_A17/EXMC_ALE Remap: TIMER3_CH0, USART2_RTS, ETH_MII_RXD3
PD13	82	I/O	5VT	Default: PD13 Alternate: EXMC_A18 Remap: TIMER3_CH1
V _{SS_8}	83	P		Default: V _{SS_8}
V _{DD_8}	84	P		Default: V _{DD_8}
PD14	85	I/O	5VT	Default: PD14 Alternate: EXMC_D0 Remap: TIMER3_CH2
PD15	86	I/O	5VT	Default: PD15 Alternate: EXMC_D1 Remap: TIMER3_CH3
PG2	87	I/O	5VT	Default: PG2 Alternate: EXMC_A12
PG3	88	I/O	5VT	Default: PG3 Alternate: EXMC_A13
PG4	89	I/O	5VT	Default: PG4 Alternate: EXMC_A14
PG5	90	I/O	5VT	Default: PG5 Alternate: EXMC_A15
PG6	91	I/O	5VT	Default: PG6 Alternate: EXMC_INT1
PG7	92	I/O	5VT	Default: PG7 Alternate: EXMC_INT2
PG8	93	I/O	5VT	Default: PG8
V _{SS_9}	94	P		Default: V _{SS_9}
V _{DD_9}	95	P		Default: V _{DD_9}
PC6	96	I/O	5VT	Default: PC6 Alternate: I2S1_MCK Remap: TIMER2_CH0
PC7	97	I/O	5VT	Default: PC7 Alternate: I2S2_MCK Remap: TIMER2_CH1
PC8	98	I/O	5VT	Default: PC8



Pin Name	Pins	Pin Type ⁽¹⁾	I/O Level ⁽²⁾	Functions description
				Remap: TIMER2_CH2
PC9	99	I/O	5VT	Default: PC9 Remap: TIMER2_CH3
PA8	100	I/O	5VT	Default: PA8 Alternate: USART0_CK, TIMER0_CH0, CK_OUT0, USBFS_SOF
PA9	101	I/O	5VT	Default: PA9 Alternate: USART0_TX, TIMER0_CH1, USBFS_VBUS
PA10	102	I/O	5VT	Default: PA10 Alternate: USART0_RX, TIMER0_CH2, USBFS_ID
PA11	103	I/O	5VT	Default: PA11 Alternate: USART0_CTS, CAN0_RX, USBFS_DM, TIMER0_CH3
PA12	104	I/O	5VT	Default: PA12 Alternate: USART0_RTS, USBFS_DP, CAN0_TX, TIMER0_ETI
PA13	105	I/O	5VT	Default: JTMS, SWDIO Remap: PA13
NC	106			-
V _{SS_2}	107	P		Default: V _{SS_2}
V _{DD_2}	108	P		Default: V _{DD_2}
PA14	109	I/O	5VT	Default: JTCK, SWCLK Remap: PA14
PA15	110	I/O	5VT	Default: JTDI Alternate: SPI2_NSS, I2S2_WS Remap: TIMER1_CH0, TIMER1_ETI, PA15, SPI0_NSS
PC10	111	I/O	5VT	Default: PC10 Alternate: UART3_TX Remap: USART2_TX, SPI2_SCK, I2S2_CK
PC11	112	I/O	5VT	Default: PC11 Alternate: UART3_RX Remap: USART2_RX, SPI2_MISO
PC12	113	I/O	5VT	Default: PC12 Alternate: UART4_TX Remap: USART2_CK, SPI2_MOSI, I2S2_SD
PD0	114	I/O	5VT	Default: PD0



Pin Name	Pins	Pin Type ⁽¹⁾	I/O Level ⁽²⁾	Functions description
				Alternate: EXMC_D2 Remap: CAN0_RX
PD1	115	I/O	5VT	Default: PD1 Alternate: EXMC_D3 Remap: CAN0_TX
PD2	116	I/O	5VT	Default: PD2 Alternate: TIMER2_ETI, UART4_RX
PD3	117	I/O	5VT	Default: PD3 Alternate: EXMC_CLK Remap: USART1_CTS
PD4	118	I/O	5VT	Default: PD4 Alternate: EXMC_NOE Remap: USART1_RTS
PD5	119	I/O	5VT	Default: PD5 Alternate: EXMC_NWE Remap: USART1_TX
V _{SS_10}	120			Default: V _{SS_10}
V _{DD_10}	121			Default: V _{DD_10}
PD6	122	I/O	5VT	Default: PD6 Alternate: EXMC_NWAIT Remap: USART1_RX
PD7	123	I/O	5VT	Default: PD7 Alternate: EXMC_NE0, EXMC_NCE1 Remap: USART1_CK
PG9	124	I/O	5VT	Default: PG9 Alternate: EXMC_NE1, EXMC_NCE2
PG10	125	I/O	5VT	Default: PG10 Alternate: EXMC_NCE3_0, EXMC_NE2
PG11	126	I/O	5VT	Default: PG11 Alternate: EXMC_NCE3_1
PG12	127	I/O	5VT	Default: PG12 Alternate: EXMC_NE3
PG13	128	I/O	5VT	Default: PG13 Alternate: EXMC_A24
PG14	129	I/O	5VT	Default: PG14 Alternate: EXMC_A25
V _{SS_11}	130	P		Default: V _{SS_11}
V _{DD_11}	131	P		Default: V _{DD_11}
PG15	132	I/O	5VT	Default: PG15



Pin Name	Pins	Pin Type ⁽¹⁾	I/O Level ⁽²⁾	Functions description
PB3	133	I/O	5VT	Default: JTDO Alternate: SPI2_SCK, I2S2_CK Remap: PB3, TRACESWO, TIMER1_CH1, SPI0_SCK
PB4	134	I/O	5VT	Default: NJTRST Alternate: SPI2_MISO Remap: TIMER2_CH0, PB4, SPI0_MISO
PB5	135	I/O		Default: PB5 Alternate: I2C0_SMBA, SPI2_MOSI, I2S2_SD, ETH_PPS_OUT Remap: TIMER2_CH1, SPI0_MOSI, CAN1_RX
PB6	136	I/O	5VT	Default: PB6 Alternate: I2C0_SCL, TIMER3_CH0 Remap: USART0_TX, CAN1_TX
PB7	137	I/O	5VT	Default: PB7 Alternate: I2C0_SDA, TIMER3_CH1, EXMC_NADV Remap: USART0_RX
BOOT0	138	I		Default: BOOT0
PB8	139	I/O	5VT	Default: PB8 Alternate: TIMER3_CH2, ETH_MII_TXD3 Remap: I2C0_SCL, CAN0_RX
PB9	140	I/O	5VT	Default: PB9 Alternate: TIMER3_CH3 Remap: I2C0_SDA, CAN0_TX
PE0	141	I/O	5VT	Default: PE0 Alternate: TIMER3_ETI, EXMC_NBL0
PE1	142	I/O	5VT	Default: PE1 Alternate: EXMC_NBL1
V _{SS_3}	143	P		Default: V _{SS_3}
V _{DD_3}	144	P		Default: V _{DD_3}

Notes:

(1) Type: I = input, O = output, P = power.

(2) I/O Level: 5VT = 5 V tolerant.



2.6.2. GD32F107Vx LQFP100 pin definitions

Table 2-5. GD32F107Vx LQFP100 pin definitions

Pin Name	Pins	Pin Type ⁽¹⁾	I/O Level ⁽²⁾	Functions description
PE2	1	I/O	5VT	Default: PE2 Alternate: TRACECK, EXMC_A23
PE3	2	I/O	5VT	Default: PE3 Alternate: TRACED0, EXMC_A19
PE4	3	I/O	5VT	Default: PE4 Alternate: TRACED1, EXMC_A20
PE5	4	I/O	5VT	Default: PE5 Alternate: TRACED2, EXMC_A21
PE6	5	I/O	5VT	Default: PE6 Alternate: TRACED3, EXMC_A22
V _{BAT}	6	P		Default: V _{BAT}
PC13- TAMPER- RTC	7	I/O		Default: PC13 Alternate: TAMPER-RTC
PC14- OSC32IN	8	I/O		Default: PC14 Alternate: OSC32IN
PC15- OSC32OUT	9	I/O		Default: PC15 Alternate: OSC32OUT
V _{SS_5}	10	P		Default: V _{SS_5}
V _{DD_5}	11	P		Default: V _{DD_5}
OSCIN	12	I		Default: OSCIN Remap: PD0
OSCOUT	13	O		Default: OSCOUT Remap: PD1
NRST	14	I/O		Default: NRST
PC0	15	I/O		Default: PC0 Alternate: ADC01_IN10
PC1	16	I/O		Default: PC1 Alternate: ADC01_IN11, ETH_MII_MDC, ETH_RMII_MDC
PC2	17	I/O		Default: PC2 Alternate: ADC01_IN12, ETH_MII_TXD2
PC3	18	I/O		Default: PC3 Alternate: ADC01_IN13, ETH_MII_TX_CLK
V _{SSA}	19	P		Default: V _{SSA}
V _{REF-}	20	P		Default: V _{REF-}



Pin Name	Pins	Pin Type ⁽¹⁾	I/O Level ⁽²⁾	Functions description
V _{REF+}	21	P		Default: V _{REF+}
V _{DDA}	22	P		Default: V _{DDA}
PA0-WKUP	23	I/O		Default: PA0 Alternate: WKUP, USART1_CTS, ADC01_IN0, TIMER1_CH0, TIMER1_ETI, TIMER4_CH0, ETH_MII_CRS
PA1	24	I/O		Default: PA1 Alternate: USART1_RTS, ADC01_IN1, TIMER1_CH1, TIMER4_CH1, ETH_MII_RX_CLK, ETH_RMII_REF_CLK
PA2	25	I/O		Default: PA2 Alternate: USART1_TX, ADC01_IN2, TIMER1_CH2, TIMER4_CH2, ETH_MII_MDIO, ETH_RMII_MDIO
PA3	26	I/O		Default: PA3 Alternate: USART1_RX, ADC01_IN3, TIMER1_CH3, TIMER4_CH3, ETH_MII_COL
V _{SS_4}	27	P		Default: V _{SS_4}
V _{DD_4}	28	P		Default: V _{DD_4}
PA4	29	I/O		Default: PA4 Alternate: SPI0_NSS, USART1_CK, ADC01_IN4, DAC_OUT0 Remap: SPI2_NSS, I2S2_WS
PA5	30	I/O		Default: PA5 Alternate: SPI0_SCK, ADC01_IN5, DAC_OUT1
PA6	31	I/O		Default: PA6 Alternate: SPI0_MISO, ADC01_IN6, TIMER2_CH0 Remap: TIMER0_BKIN
PA7	32	I/O		Default: PA7 Alternate: SPI0_MOSI, ADC01_IN7, TIMER2_CH1, ETH_MII_RX_DV, ETH_RMII_CRS_DV Remap: TIMER0_CH0_ON
PC4	33	I/O		Default: PC4 Alternate: ADC01_IN14, ETH_MII_RXD0, ETH_RMII_RXD0
PC5	34	I/O		Default: PC5 Alternate: ADC01_IN15, ETH_MII_RXD1,



Pin Name	Pins	Pin Type ⁽¹⁾	I/O Level ⁽²⁾	Functions description
				ETH_RMII_RXD1
PB0	35	I/O		Default: PB0 Alternate: ADC01_IN8, TIMER2_CH2, ETH_MII_RXD2 Remap: TIMER0_CH1_ON
PB1	36	I/O		Default: PB1 Alternate: ADC01_IN9, TIMER2_CH3, ETH_MII_RXD3 Remap: TIMER0_CH2_ON
PB2	37	I/O	5VT	Default: PB2, BOOT1
PE7	38	I/O	5VT	Default: PE7 Alternate: EXMC_D4 Remap: TIMER0_ETI
PE8	39	I/O	5VT	Default: PE8 Alternate: EXMC_D5 Remap: TIMER0_CH0_ON
PE9	40	I/O	5VT	Default: PE9 Alternate: EXMC_D6 Remap: TIMER0_CH0
PE10	41	I/O	5VT	Default: PE10 Alternate: EXMC_D7 Remap: TIMER0_CH1_ON
PE11	42	I/O	5VT	Default: PE11 Alternate: EXMC_D8 Remap: TIMER0_CH1
PE12	43	I/O	5VT	Default: PE12 Alternate: EXMC_D9 Remap: TIMER0_CH2_ON
PE13	44	I/O	5VT	Default: PE13 Alternate: EXMC_D10 Remap: TIMER0_CH2
PE14	45	I/O	5VT	Default: PE14 Alternate: EXMC_D11 Remap: TIMER0_CH3
PE15	46	I/O	5VT	Default: PE15 Alternate: EXMC_D12 Remap: TIMER0_BKIN
PB10	47	I/O	5VT	Default: PB10 Alternate: I2C1_SCL ⁽³⁾ , USART2_TX,



Pin Name	Pins	Pin Type ⁽¹⁾	I/O Level ⁽²⁾	Functions description
				ETH_MII_RX_ER Remap: TIMER1_CH2
PB11	48	I/O	5VT	Default: PB11 Alternate: I2C1_SDA ⁽³⁾ , USART2_RX, ETH_MII_TX_EN, ETH_RMII_TX_EN Remap: TIMER1_CH3
V _{SS_1}	49	P		Default: V _{SS_1}
V _{DD_1}	50	P		Default: V _{DD_1}
PB12	51	I/O	5VT	Default: PB12 Alternate: SPI1_NSS, I2C1_SMBA ⁽³⁾ , USART2_CK, TIMER0_BKIN, I2S1_WS, CAN1_RX, ETH_MII_TXD0, ETH_RMII_TXD0
PB13	52	I/O	5VT	Default: PB13 Alternate: SPI1_SCK, USART2_CTS, TIMER0_CH0_ON, I2S1_CK, CAN1_TX, ETH_MII_TXD1, ETH_RMII_TXD1
PB14	53	I/O	5VT	Default: PB14 Alternate: SPI1_MISO, USART2_RTS, TIMER0_CH1_ON
PB15	54	I/O	5VT	Default: PB15 Alternate: SPI1_MOSI, TIMER0_CH2_ON, I2S1_SD
PD8	55	I/O	5VT	Default: PD8 Alternate: EXMC_D13 Remap: USART2_TX, ETH_MII_RX_DV, ETH_RMII_CRS_DV
PD9	56	I/O	5VT	Default: PD9 Alternate: EXMC_D14 Remap: USART2_RX, ETH_MII_RXD0, ETH_RMII_RXD0
PD10	57	I/O	5VT	Default: PD10 Alternate: EXMC_D15 Remap: USART2_CK, ETH_MII_RXD1, ETH_RMII_RXD1
PD11	58	I/O	5VT	Default: PD11 Alternate: EXMC_A16/EXMC_CLE Remap: USART2_CTS, ETH_MII_RXD2
PD12	59	I/O	5VT	Default: PD12 Alternate: EXMC_A17/EXMC_ALE



Pin Name	Pins	Pin Type ⁽¹⁾	I/O Level ⁽²⁾	Functions description
				Remap: TIMER3_CH0, USART2_RTS, ETH_MII_RXD3
PD13	60	I/O	5VT	Default: PD13 Alternate: EXMC_A18 Remap: TIMER3_CH1
PD14	61	I/O	5VT	Default: PD14 Alternate: EXMC_D0 Remap: TIMER3_CH2
PD15	62	I/O	5VT	Default: PD15 Alternate: EXMC_D1 Remap: TIMER3_CH3
PC6	63	I/O	5VT	Default: PC6 Alternate: I2S1_MCK Remap: TIMER2_CH0
PC7	64	I/O	5VT	Default: PC7 Alternate: I2S2_MCK Remap: TIMER2_CH1
PC8	65	I/O	5VT	Default: PC8 Remap: TIMER2_CH2
PC9	66	I/O	5VT	Default: PC9 Remap: TIMER2_CH3
PA8	67	I/O	5VT	Default: PA8 Alternate: USART0_CK, TIMER0_CH0, CK_OUT0, USBFS_SOF
PA9	68	I/O	5VT	Default: PA9 Alternate: USART0_TX, TIMER0_CH1, USBFS_VBUS
PA10	69	I/O	5VT	Default: PA10 Alternate: USART0_RX, TIMER0_CH2, USBFS_ID
PA11	70	I/O	5VT	Default: PA11 Alternate: USART0_CTS, CAN0_RX, USBFS_DM, TIMER0_CH3
PA12	71	I/O	5VT	Default: PA12 Alternate: USART0_RTS, USBFS_DP, CAN0_TX, TIMER0_ETI
PA13	72	I/O	5VT	Default: JTMS, SWDIO Remap: PA13
NC	73			-



Pin Name	Pins	Pin Type ⁽¹⁾	I/O Level ⁽²⁾	Functions description
V _{SS_2}	74	P		Default: V _{SS_2}
V _{DD_2}	75	P		Default: V _{DD_2}
PA14	76	I/O	5VT	Default: JTCK, SWCLK Remap: PA14
PA15	77	I/O	5VT	Default: JTDI Alternate: SPI2_NSS, I2S2_WS Remap: TIMER1_CH0, TIMER1_ETI, PA15, SPI0_NSS
PC10	78	I/O	5VT	Default: PC10 Alternate: UART3_TX Remap: USART2_TX, SPI2_SCK, I2S2_CK
PC11	79	I/O	5VT	Default: PC11 Alternate: UART3_RX Remap: USART2_RX, SPI2_MISO
PC12	80	I/O	5VT	Default: PC12 Alternate: UART4_TX Remap: USART2_CK, SPI2_MOSI, I2S2_SD
PD0	81	I/O	5VT	Default: PD0 Alternate: EXMC_D2 Remap: CAN0_RX
PD1	82	I/O	5VT	Default: PD1 Alternate: EXMC_D3 Remap: CAN0_TX
PD2	83	I/O	5VT	Default: PD2 Alternate: TIMER2_ETI, UART4_RX
PD3	84	I/O	5VT	Default: PD3 Alternate: EXMC_CLK Remap: USART1_CTS
PD4	85	I/O	5VT	Default: PD4 Alternate: EXMC_NOE Remap: USART1_RTS
PD5	86	I/O	5VT	Default: PD5 Alternate: EXMC_NWE Remap: USART1_TX
PD6	87	I/O	5VT	Default: PD6 Alternate: EXMC_NWAIT Remap: USART1_RX
PD7	88	I/O	5VT	Default: PD7 Alternate: EXMC_NE0, EXMC_NCE1



Pin Name	Pins	Pin Type ⁽¹⁾	I/O Level ⁽²⁾	Functions description
				Remap: USART1_CK
PB3	89	I/O	5VT	Default: JTDO Alternate: SPI2_SCK, I2S2_CK Remap: PB3, TRACESWO, TIMER1_CH1, SPI0_SCK
PB4	90	I/O	5VT	Default: NJTRST Alternate: SPI2_MISO Remap: TIMER2_CH0, PB4, SPI0_MISO
PB5	91	I/O		Default: PB5 Alternate: I2C0_SMBA, SPI2_MOSI, I2S2_SD, ETH_PPS_OUT Remap: TIMER2_CH1, SPI0_MOSI, CAN1_RX
PB6	92	I/O	5VT	Default: PB6 Alternate: I2C0_SCL, TIMER3_CH0 Remap: USART0_TX, CAN1_TX
PB7	93	I/O	5VT	Default: PB7 Alternate: I2C0_SDA, TIMER3_CH1, EXMC_NADV Remap: USART0_RX
BOOT0	94	I		Default: BOOT0
PB8	95	I/O	5VT	Default: PB8 Alternate: TIMER3_CH2, ETH_MII_TXD3 Remap: I2C0_SCL, CAN0_RX
PB9	96	I/O	5VT	Default: PB9 Alternate: TIMER3_CH3 Remap: I2C0_SDA, CAN0_TX
PE0	97	I/O	5VT	Default: PE0 Alternate: TIMER3_ETI, EXMC_NBL0
PE1	98	I/O	5VT	Default: PE1 Alternate: EXMC_NBL1
V _{SS_3}	99	P		Default: V _{SS_3}
V _{DD_3}	100	P		Default: V _{DD_3}

Notes:

- (1) Type: I = input, O = output, P = power.
(2) I/O Level: 5VT = 5 V tolerant.
(3) Functions are available in GD32F107VD/E/F/G devices.

2.6.3. GD32F107Rx LQFP64 pin definitions

Table 2-6. GD32F107Rx LQFP64 pin definitions

Pin Name	Pins	Pin Type ⁽¹⁾	I/O Level ⁽²⁾	Functions description
V _{BAT}	1	P		Default: V _{BAT}
PC13-TAMPER-RTC	2	I/O		Default: PC13 Alternate: TAMPER-RTC
PC14-OSC32IN	3	I/O		Default: PC14 Alternate: OSC32IN
PC15-OSC32OUT	4	I/O		Default: PC15 Alternate: OSC32OUT
OSCIN	5	I		Default: OSCIN
OSCOUT	6	O		Default: OSCOUT
NRST	7	I/O		Default: NRST
PC0	8	I/O		Default: PC0 Alternate: ADC01_IN10
PC1	9	I/O		Default: PC1 Alternate: ADC01_IN11, ETH_MII_MDC, ETH_RMII_MDC
PC2	10	I/O		Default: PC2 Alternate: ADC01_IN12, ETH_MII_TXD2
PC3	11	I/O		Default: PC3 Alternate: ADC01_IN13, ETH_MII_TX_CLK
V _{SSA}	12	P		Default: V _{SSA}
V _{DDA}	13	P		Default: V _{DDA}
PA0-WKUP	14	I/O		Default: PA0 Alternate: WKUP, USART1_CTS, ADC01_IN0, TIMER1_CH0, TIMER1_ETI, TIMER4_CH0, ETH_MII_CRS
PA1	15	I/O		Default: PA1 Alternate: USART1_RTS, ADC01_IN1, TIMER1_CH1, TIMER4_CH1, ETH_MII_RX_CLK, ETH_RMII_REF_CLK
PA2	16	I/O		Default: PA2 Alternate: USART1_TX, ADC01_IN2, TIMER1_CH2, TIMER4_CH2, ETH_MII_MDIO, ETH_RMII_MDIO
PA3	17	I/O		Default: PA3 Alternate: USART1_RX, ADC01_IN3,



Pin Name	Pins	Pin Type ⁽¹⁾	I/O Level ⁽²⁾	Functions description
				TIMER1_CH3, TIMER4_CH3, ETH_MII_COL
V _{SS_4}	18	P		Default: V _{SS_4}
V _{DD_4}	19	P		Default: V _{DD_4}
PA4	20	I/O		Default: PA4 Alternate: SPI0_NSS, USART1_CK, ADC01_IN4, DAC_OUT0 Remap: SPI2_NSS, I2S2_WS
PA5	21	I/O		Default: PA5 Alternate: SPI0_SCK, ADC01_IN5, DAC_OUT1
PA6	22	I/O		Default: PA6 Alternate: SPI0_MISO, ADC01_IN6, TIMER2_CH0 Remap: TIMER0_BKIN
PA7	23	I/O		Default: PA7 Alternate: SPI0_MOSI, ADC01_IN7, TIMER2_CH1, ETH_MII_RX_DV, ETH_RMII_CRS_DV Remap: TIMER0_CH0_ON
PC4	24	I/O		Default: PC4 Alternate: ADC01_IN14, ETH_MII_RXD0, ETH_RMII_RXD0
PC5	25	I/O		Default: PC5 Alternate: ADC01_IN15, ETH_MII_RXD1, ETH_RMII_RXD1
PB0	26	I/O		Default: PB0 Alternate: ADC01_IN8, TIMER2_CH2, ETH_MII_RXD2 Remap: TIMER0_CH1_ON
PB1	27	I/O		Default: PB1 Alternate: ADC01_IN9, TIMER2_CH3, ETH_MII_RXD3 Remap: TIMER0_CH2_ON
PB2	28	I/O	5VT	Default: PB2, BOOT1
PB10	29	I/O	5VT	Default: PB10 Alternate: I2C1_SCL ⁽³⁾ , USART2_TX, ETH_MII_RX_ER Remap: TIMER1_CH2
PB11	30	I/O	5VT	Default: PB11 Alternate: I2C1_SDA ⁽³⁾ , USART2_RX,



Pin Name	Pins	Pin Type ⁽¹⁾	I/O Level ⁽²⁾	Functions description
				ETH_MII_TX_EN, ETH_RMII_TX_EN Remap: TIMER1_CH3
V _{SS_1}	31	P		Default: V _{SS_1}
V _{DD_1}	32	P		Default: V _{DD_1}
PB12	33	I/O	5VT	Default: PB12 Alternate: SPI1_NSS, I2C1_SMBA ⁽³⁾ , USART2_CK, TIMER0_BKIN, I2S1_WS, CAN1_RX, ETH_MII_TXD0, ETH_RMII_TXD0
PB13	34	I/O	5VT	Default: PB13 Alternate: SPI1_SCK, USART2_CTS, TIMER0_CH0_ON, I2S1_CK, CAN1_TX, ETH_MII_TXD1, ETH_RMII_TXD1
PB14	35	I/O	5VT	Default: PB14 Alternate: SPI1_MISO, USART2_RTS, TIMER0_CH1_ON
PB15	36	I/O	5VT	Default: PB15 Alternate: SPI1_MOSI, TIMER0_CH2_ON, I2S1_SD
PC6	37	I/O	5VT	Default: PC6 Alternate: I2S1_MCK Remap: TIMER2_CH0
PC7	38	I/O	5VT	Default: PC7 Alternate: I2S2_MCK Remap: TIMER2_CH1
PC8	39	I/O	5VT	Default: PC8 Remap: TIMER2_CH2
PC9	40	I/O	5VT	Default: PC9 Remap: TIMER2_CH3
PA8	41	I/O	5VT	Default: PA8 Alternate: USART0_CK, TIMER0_CH0, CK_OUT0, USBFS_SOF
PA9	42	I/O	5VT	Default: PA9 Alternate: USART0_TX, TIMER0_CH1, USBFS_VBUS
PA10	43	I/O	5VT	Default: PA10 Alternate: USART0_RX, TIMER0_CH2, USBFS_ID
PA11	44	I/O	5VT	Default: PA11 Alternate: USART0_CTS, CAN0_RX,



Pin Name	Pins	Pin Type ⁽¹⁾	I/O Level ⁽²⁾	Functions description
				USBFS_DM, TIMER0_CH3
PA12	45	I/O	5VT	Default: PA12 Alternate: USART0_RTS, USBFS_DP, CAN0_TX, TIMER0_ETI
PA13	46	I/O	5VT	Default: JTMS, SWDIO Remap: PA13
V _{SS_2}	47	P		Default: V _{SS_2}
V _{DD_2}	48	P		Default: V _{DD_2}
PA14	49	I/O	5VT	Default: JTCK, SWCLK Remap: PA14
PA15	50	I/O	5VT	Default: JTDI Alternate: SPI2_NSS, I2S2_WS Remap: TIMER1_CH0, TIMER1_ETI, PA15, SPI0_NSS
PC10	51	I/O	5VT	Default: PC10 Alternate: UART3_TX Remap: USART2_TX, SPI2_SCK, I2S2_CK
PC11	52	I/O	5VT	Default: PC11 Alternate: UART3_RX Remap: USART2_RX, SPI2_MISO
PC12	53	I/O	5VT	Default: PC12 Alternate: UART4_TX Remap: USART2_CK, SPI2_MOSI, I2S2_SD
PD2	54	I/O	5VT	Default: PD2 Alternate: TIMER2_ETI, UART4_RX
PB3	55	I/O	5VT	Default: JTDO Alternate: SPI2_SCK, I2S2_CK Remap: PB3, TRACESWO, TIMER1_CH1, SPI0_SCK
PB4	56	I/O	5VT	Default: NJTRST Alternate: SPI2_MISO Remap: TIMER2_CH0, PB4, SPI0_MISO
PB5	57	I/O		Default: PB5 Alternate: I2C0_SMBA, SPI2_MOSI, I2S2_SD, ETH_PPS_OUT Remap: TIMER2_CH1, SPI0_MOSI, CAN1_RX
PB6	58	I/O	5VT	Default: PB6 Alternate: I2C0_SCL, TIMER3_CH0 Remap: USART0_TX, CAN1_TX



Pin Name	Pins	Pin Type ⁽¹⁾	I/O Level ⁽²⁾	Functions description
PB7	59	I/O	5VT	Default: PB7 Alternate: I2C0_SDA , TIMER3_CH1 Remap: USART0_RX
BOOT0	60	I		Default: BOOT0
PB8	61	I/O	5VT	Default: PB8 Alternate: TIMER3_CH2, ETH_MII_TXD3 Remap: I2C0_SCL, CAN0_RX
PB9	62	I/O	5VT	Default: PB9 Alternate: TIMER3_CH3 Remap: I2C0_SDA, CAN0_TX
V _{SS_3}	63	P		Default: V _{SS_3}
V _{DD_3}	64	P		Default: V _{DD_3}

Notes:

- (1) Type: I = input, O = output, P = power.
- (2) I/O Level: 5VT = 5 V tolerant.
- (3) Functions are available in GD32F107RD/E/F/G devices.

3. Functional description

3.1. Arm® Cortex®-M3 core

The Cortex®-M3 processor is the latest generation of Arm® processors for embedded systems. It has been developed to provide a low-cost platform that meets the needs of MCU implementation, with a reduced pin count and low-power consumption, while delivering outstanding computational performance and an advanced system response to interrupts.

- 32-bit Arm® Cortex®-M3 processor core
- Up to 108 MHz operation frequency
- Single-cycle multiplication and hardware divider
- Integrated Nested Vectored Interrupt Controller (NVIC)
- 24-bit SysTick timer

The Cortex®-M3 processor is based on the ARMv7 architecture and supports both Thumb and Thumb-2 instruction sets. Some system peripherals listed below are also provided by Cortex®-M3:

- Internal Bus Matrix connected with ICode bus, DCode bus, system bus, Private Peripheral Bus (PPB) and debug accesses (AHB-AP)
- Nested Vectored Interrupt Controller (NVIC)
- Flash Patch and Breakpoint (FPB)
- Data Watchpoint and Trace (DWT)
- Instrument Trace Macrocell (ITM)
- Memory Protection Unit (MPU)
- Serial Wire JTAG Debug Port (SWJ-DP)
- Trace Port Interface Unit (TPIU)

3.2. On-chip memory

- Up to 1024 Kbytes of Flash memory
- The region of the MCU executing instructions without waiting time is up to 256K bytes (in case that Flash size less than or equal to 256K, all memory is no waiting time). A long delay when CPU fetches the instructions out of the range.
- 96 Kbytes of SRAM

The Arm® Cortex®-M3 processor is structured in Harvard architecture which can use separate buses to fetch instructions and load/store data. 1024 Kbytes of inner Flash at most, which includes code Flash and data Flash, is available for storing programs and data, and there is no waiting time within code Flash area when CPU executes instructions. The [Table 2-3. GD32F107xx memory map](#) shows the memory map of the GD32F107xx series of devices, including code, SRAM, peripheral, and other pre-defined regions.

3.3. Clock, reset and supply management

- Internal 8 MHz factory-trimmed RC and external 3 to 25 MHz crystal oscillator
- Internal 40 KHz RC calibrated oscillator and external 32.768 KHz crystal oscillator
- Integrated system clock PLL
- 2.6 to 3.6 V application supply and I/Os
- Supply Supervisor: POR (Power On Reset), PDR (Power Down Reset), and low voltage detector (LVD)

The Clock Control Unit (CCU) provides a range of oscillator and clock functions. These include speed internal RC oscillator and external crystal oscillator, high speed and low speed two types. Several prescalers allow the configuration of the AHB frequency, the high-speed APB (APB2) and the low-speed APB (APB1) domains. The maximum frequency of the AHB and the high-speed APB domains is 108 MHz. The maximum allowed frequency of the low-speed APB domain is 54 MHz. See [Figure 2-5. GD32F107xx clock tree](#) for details on the clock tree.

The Reset Control Unit (RCU) controls three kinds of reset: system reset resets the processor core and peripheral IP components. Power-on reset (POR) and power-down reset (PDR) are always active, and ensures proper operation starting from/down to 2.6 V. The device remains in reset mode when V_{DD} is below a specified threshold. The embedded low voltage detector (LVD) monitors the power supply, compares it to the voltage threshold and generates an interrupt as a warning message for leading the MCU into security.

Power supply schemes:

- V_{DD} range: 2.6 to 3.6 V, external power supply for I/Os and the internal regulator. Provided externally through V_{DD} pins.
- V_{SSA} , V_{DDA} range: 2.6 to 3.6 V, external analog power supplies for ADC, reset blocks, RCs and PLL. V_{DDA} and V_{SSA} must be connected to V_{DD} and V_{SS} , respectively.
- V_{BAT} range: 1.8 to 3.6 V, power supply for RTC, external clock 32 kHz oscillator and backup registers (through power switch) when V_{DD} is not present.

3.4. Boot modes

At startup, boot pins are used to select one of three boot options:

- Boot from main flash memory (default)
- Boot from system memory
- Boot from on-chip SRAM

The boot loader is located in the internal boot ROM memory (system memory). It is used to reprogram the Flash memory by using USART0 (PA9 and PA10), USART1 (PD5 and PD6), USBFS in device mode (PA9, PA11 and PA12). It also can be used to transfer and update the Flash memory code, the data and the vector table sections. In default condition, boot from bank 0 of Flash memory is selected. It also supports to boot from bank 1 of Flash memory by

setting a bit in option bytes.

3.5. Power saving modes

The MCU supports three kinds of power saving modes to achieve even lower power consumption. They are sleep mode, deep-sleep mode, and standby mode. These operating modes reduce the power consumption and allow the application to achieve the best balance between the CPU operating time, speed and power consumption.

- **Sleep mode**

In sleep mode, only the clock of CPU core is off. All peripherals continue to operate and any interrupt/event can wake up the system.

- **Deep-sleep mode**

In deep-sleep mode, all clocks in the 1.2V domain are off, and all of the high speed crystal oscillator (IRC8M, HXTAL) and PLL are disabled. Only the contents of SRAM and registers are retained. Any interrupt or wakeup event from EXTI lines can wake up the system from the deep-sleep mode including the 16 external lines, the RTC alarm, the LVD output, and USB wakeup. When exiting the Deep-sleep mode, the IRC8M is selected as the system clock.

- **Standby mode**

In standby mode, the whole 1.2V domain is power off, the LDO is shut down, and all of IRC8M, HXTAL and PLL are disabled. The contents of SRAM and registers (except Backup registers) are lost. There are four wakeup sources for the standby mode, including the external reset from NRST pin, the RTC alarm, the FWDGT reset, and the rising edge on WKUP pin.

3.6. Analog to digital converter (ADC)

- 12-bit SAR ADC engine
- Up to 1 MSPS conversion rate
- Conversion range: V_{SSA} to V_{DDA} (2.6 to 3.6 V)
- Temperature sensor

Up to two 12-bit 1 μ s multi-channel ADCs are integrated in the device. Each is a total of up to 21 multiplexed external channels. An analog watchdog block can be used to detect the channels, which are required to remain within a specific threshold window. A configurable channel management block of analog inputs also can be used to perform conversions in single, continuous, scan or discontinuous mode to support more advanced usages.

The ADCs can be triggered from the events generated by the general-purpose timers (TIMERx) and the advanced-control timer (TIMER0) with internal connection. The temperature sensor has to generate a voltage that varies linearly with temperature. The conversion range is between $2.6\text{ V} < V_{DDA} < 3.6\text{ V}$. The temperature sensor is internally connected to the ADC_IN16 input channel which is used to convert the sensor output voltage

into a digital value.

To ensure a high accuracy on ADC and DAC, the ADC/DAC independent external reference voltage should be connected to V_{REF+}/V_{REF-} pins. According to the different packages, V_{REF+} pin can be connected to V_{DDA} pin, or external reference voltage, V_{REF-} pin must be connected to V_{SSA} pin. The V_{REF+} pin is only available on no less than 100-pin packages. On less than 100-pin packages, the V_{REF+} pin is not available and it is internally connected to V_{DDA} . The V_{REF-} pin is internally connected to V_{SSA} .

3.7. Digital to analog converter (DAC)

- Two 12-bit DAC converters of independent output channel
- 8-bit or 12-bit mode in conjunction with the DMA controller

The two 12-bit buffered DAC channels are used to generate variable analog outputs. The DACs are designed with integrated resistor strings structure. The DAC channels can be triggered by the timer update outputs or EXTI with DMA support. In dual DAC channel operation, conversions could be done independently or simultaneously. The maximum output value of the DAC is V_{REF+} .

3.8. DMA

- 7 channel DMA0 controller and 5 channel DMA1 controller
- Peripherals supported: Timers, ADC, SPIs, I²Cs, USARTs, DAC, I²S
- Dedicated DMA controller with the Ethernet application

The flexible general-purpose DMA controllers provide a hardware method of transferring data between peripherals and/or memory without intervention from the CPU, thereby freeing up bandwidth for other system functions. Four types of access method are supported: peripheral to peripheral, peripheral to memory, memory to peripheral, memory to memory

Each channel is connected to fixed hardware DMA requests. The priorities of DMA channel requests are determined by software configuration and hardware channel number. Transfer size of source and destination are independent and configurable.

3.9. General-purpose inputs/outputs (GPIOs)

- Up to 112 fast GPIOs, all mappable on 16 external interrupt vectors (EXTI)
- Analog input/output configurable
- Alternate function input/output configurable

There are up to 112 general purpose I/O pins (GPIO) in GD32F107xx, named PA0 ~ PA15 and PB0 ~ PB15, PC0 ~ PC15, PD0 ~ PD15, PE0 ~ PE15, PF0-PF15, PG0-PG15 to implement logic input/output functions. Each of the GPIO ports has related control and

configuration registers to satisfy the requirements of specific applications. The external interrupts on the GPIO pins of the device have related control and configuration registers in the External Interrupt Control Unit (EXTI). The GPIO ports are pin-shared with other alternative functions (AFs) to obtain maximum flexibility on the package pins. Each of the GPIO pins can be configured by software as output (push-pull or open-drain), as input (with or without pull-up or pull-down) or as peripheral alternate function. Most of the GPIO pins are shared with digital or analog alternate functions. All GPIOs are high-current capable except for analog inputs.

3.10. Timers and PWM generation

- One 16-bit advanced-control timer (TIMER0), four 16-bit general-purpose timers (GPTM), and two 16-bit basic timer (TIMER5 & TIMER6)
- Up to 4 independent channels of PWM, output compare or input capture for each GPTM and external trigger input
- 16-bit, motor control PWM advanced-control timer with programmable dead-time generation for output match
- Encoder interface controller with two inputs using quadrature decoder
- 24-bit SysTick timer down counter
- 2 watchdog timers (Free watchdog timer and window watchdog timer)

The advanced-control timer (TIMER0) can be seen as a three-phase PWM multiplexed on 6 channels. It has complementary PWM outputs with programmable dead-time generation. It can also be used as a complete general-purpose timer. The 4 independent channels can be used for

- Input capture
- Output compare
- PWM generation (edge- or center-aligned counting modes)
- Single pulse mode output

If configured as a general-purpose 16-bit timer, it has the same functions as the TIMER x timer. It can be synchronized with external signals or to interconnect with other GPTMs together which have the same architecture and features.

The general-purpose timer (GPTM), known as TIMER1 ~ TIMER4 can be used for a variety of purposes including general time, input signal pulse width measurement or output waveform generation such as a single pulse generation or PWM output, up to 4 independent channels for input capture/output compare. The GPTM also supports an encoder interface with two inputs using quadrature decoder.

The basic timer, known as TIMER5 and TIMER6 are mainly used for DAC trigger generation. They can also be used as a simple 16-bit time base.

The GD32F107xx have two watchdog peripherals, free watchdog timer and window watchdog timer. They offer a combination of high safety level, flexibility of use and timing accuracy.

The free watchdog timer includes a 12-bit down-counting counter and an 8-bit prescaler, It is clocked from an independent 40 kHz internal RC and as it operates independently of the main clock, it can operate in deep-sleep and standby modes. It can be used either as a watchdog to reset the device when a problem occurs, or as a free-running timer for application timeout management.

The window watchdog timer is based on a 7-bit down counter that can be set as free-running. It can be used as a watchdog to reset the device when a problem occurs. It is clocked from the main clock. It has an early warning interrupt capability and the counter can be frozen in debug mode.

The SysTick timer is dedicated for OS, but could also be used as a standard down counter. It features:

- A 24-bit down counter
- Auto reload capability
- Maskable system interrupt generation when the counter reaches 0
- Programmable clock source

3.11. Real time clock (RTC)

- 32-bit up-counter with a programmable 20-bit prescaler
- Alarm function
- Interrupt and wake-up event

The real time clock is an independent timer which provides a set of continuously running counters which can be used with suitable software to provide a clock calendar function, and provides an alarm interrupt and an expected interrupt. The RTC features a 32-bit programmable counter for long-term measurement using the compare register to generate an alarm. A 20-bit prescaler is used for the time base clock and is by default configured to generate a time base of 1 second from a clock at 32.768 kHz from external crystal oscillator.

3.12. Inter-integrated circuit (I2C)

- Up to two I2C bus interfaces can support both master and slave mode with a frequency up to 400 kHz
- Provide arbitration function, optional PEC (packet error checking) generation and checking
- Supports 7-bit and 10-bit addressing mode and general call addressing mode

The I2C interface is an internal circuit allowing communication with an external I2C interface which is an industry standard two line serial interface used for connection to external hardware. These two serial lines are known as a serial data line (SDA) and a serial clock line (SCL). The I2C module provides transfer rate of up to 100 KHz in standard mode and up to 400 KHz in fast mode. The I2C module also has an arbitration detect function to prevent the

situation where more than one master attempts to transmit data to the I2C bus at the same time. A CRC-8 calculator is also provided in I2C interface to perform packet error checking for I2C data.

3.13. Serial peripheral interface (SPI)

- Up to three SPI interfaces with a frequency of up to 18 MHz
- Support both master and slave mode
- Hardware CRC calculation and transmit automatic CRC error checking

The SPI interface uses 4 pins, among which are the serial data input and output lines (MISO & MOSI), the clock line (SCK) and the slave select line (NSS). Both SPIs can be served by the DMA controller. The SPI interface may be used for a variety of purposes, including simplex synchronous transfers on two lines with a possible bidirectional data line or reliable communication using CRC checking.

3.14. Universal synchronous asynchronous receiver transmitter (USART)

- Up to three USARTs and two UARTs with operating frequency up to 6.75 MHz
- Supports both asynchronous and clocked synchronous serial communication modes
- IrDA SIR encoder and decoder support
- LIN break generation and detection
- USARTs support ISO 7816-3 compliant smart card interface

The USART (USART0, USART1 and USART2) are used to translate data between parallel and serial interfaces, provides a flexible full duplex data exchange using synchronous or asynchronous transfer. It is also commonly used for RS-232 standard communication. The USART includes a programmable baud rate generator which is capable of dividing the system clock to produce a dedicated clock for the USART transmitter and receiver. The USART also supports DMA function for high speed data communication except UART4.

3.15. Inter-IC sound (I2S)

- Two I2S bus Interfaces with sampling frequency from 8 kHz to 192 kHz
- Support either master or slave mode

The Inter-IC sound (I2S) bus provides a standard communication interface for digital audio applications by 3-wire serial lines. GD32F107xx contain two I2S-bus interfaces that can be operated with 16/32 bit resolution in master or slave mode, pin multiplexed with SPI1 and SPI2. The audio sampling frequency from 8 kHz to 192 kHz is supported with less than 0.5% accuracy error.

3.16. Universal serial bus full-speed (USBFS)

- One USB device/host/OTG full-speed Interface with frequency up to 12 Mbit/s
- Internal main PLL for USB CLK compliantly

The Universal Serial Bus (USB) is a 4-wire bus with 4 bidirectional endpoints. The device controller enables 12 Mbit/s data exchange with integrated transceivers in device/host/OTG mode. Full-speed peripheral is compliant with the USB 2.0 specification. Transaction formatting is performed by the hardware, including CRC generation and checking. The status of a completed USB transfer or error condition is indicated by status registers. An interrupt is also generated if enabled. The dedicated 48 MHz clock is generated from the internal main PLL (the clock source must use a HXTAL crystal oscillator) and the operating frequency divided from APB1 should be 12 MHz above.

3.17. Controller area network (CAN)

- Two CAN2.0B interface with communication frequency up to 1 Mbit/s
- Internal main PLL for USB CLK compliantly

Controller area network (CAN) is a method for enabling serial communication in field bus. The CAN protocol has been used extensively in industrial automation and automotive applications. It can receive and transmit standard frames with 11-bit identifiers as well as extended frames with 29-bit identifiers. Each CAN has three mailboxes for transmission and two FIFOs of three message deep for reception. It also provides 14 scalable/configurable identifier filter banks for selecting the incoming messages needed and discarding the others.

3.18. Ethernet MAC interface

- IEEE 802.3 compliant media access controller (MAC) for Ethernet LAN
- 10/100 Mbit/s rates with dedicated DMA controller and SRAM
- Support hardware precision time protocol (PTP) with conformity to IEEE 1588

The Ethernet media access controller (MAC) conforms to IEEE 802.3 specifications and fully supports IEEE 1588 standards. The embedded MAC provides the interface to the required external network physical interface (PHY) for LAN bus connection via an internal media independent interface (MII) or a reduced media independent interface (RMII). The number of MII signals provided up to 17 with 25 MHz output and RMII up to 9 with 50 MHz output. The function of 32-bit CRC checking is also available.

3.19. External memory controller (EXMC)

- Supported external memory: SRAM, PSRAM, ROM and NOR-Flash, NAND Flash and

CF card

- Up to 16-bit data bus
- Support to interface with Motorola 6800 and Intel 8080 type LCD directly

External memory controller (EXMC) is an abbreviation of external memory controller. It is divided in to several sub-banks for external device support, each sub-bank has its own chip selection signal but at one time, only one bank can be accessed. The EXMC support code execution from external memory except NAND Flash and CF card. The EXMC also can be configured to interface with the most common LCD module of Motorola 6800 and Intel 8080 series and reduce the system cost and complexity.

3.20. Debug mode

- Serial wire JTAG debug port (SWJ-DP)

The Arm® SWJ-DP Interface is embedded and is a combined JTAG and serial wire debug port that enables either a serial wire debug or a JTAG probe to be connected to the target.

3.21. Package and operation temperature

- LQFP144 (GD32F107Zx), LQFP100 (GD32F107Vx), LQFP64 (GD32F107Rx)
- Operation temperature range: -40°C to +85°C (industrial level)

4. Electrical characteristics

4.1. Absolute maximum ratings

The maximum ratings are the limits to which the device can be subjected without permanently damaging the device. Note that the device is not guaranteed to operate properly at the maximum ratings. Exposure to the absolute maximum rating conditions for extended periods may affect device reliability.

Table 4-1. Absolute maximum ratings⁽¹⁾⁽⁴⁾

Symbol	Parameter	Min	Max	Unit
V _{DD}	External voltage range ⁽²⁾	V _{SS} - 0.3	V _{SS} + 3.6	V
V _{DDA}	External analog supply voltage	V _{SSA} - 0.3	V _{SSA} + 3.6	V
V _{BAT}	External battery supply voltage	V _{SS} - 0.3	V _{SS} + 3.6	V
V _{IN}	Input voltage on 5V tolerant pin ⁽³⁾	V _{SS} - 0.3	V _{DD} + 3.6	V
	Input voltage on other I/O	V _{SS} - 0.3	3.6	V
ΔV _{DDX}	Variations between different V _{DD} power pins	—	50	mV
V _{SSX} - V _{SS}	Variations between different ground pins	—	50	mV
I _{IO}	Maximum current for GPIO pins	—	±25	mA
T _A	Operating temperature range	-40	+85	°C
P _D	Power dissipation at T _A = 85°C of LQFP144	—	820	mW
	Power dissipation at T _A = 85°C of LQFP100	—	697	
	Power dissipation at T _A = 85°C of LQFP64	—	647	
T _{STG}	Storage temperature range	-65	+150	°C
T _J	Maximum junction temperature	—	125	°C

(1) Guaranteed by design, not tested in production.

(2) All main power and ground pins should be connected to an external power source within the allowable range.

(3) V_{IN} maximum value cannot exceed 5.5 V.

(4) It is recommended that V_{DD} and V_{DDA} are powered by the same source. The maximum difference between V_{DD} and V_{DDA} does not exceed 300 mV during power-up and operation.

4.2. Operating conditions characteristics

Table 4-2. DC operating conditions

Symbol	Parameter	Conditions	Min ⁽¹⁾	Typ	Max ⁽¹⁾	Unit
V _{DD}	Supply voltage	—	2.6	3.3	3.6	V
V _{DDA}	Analog supply voltage	Same as V _{DD}	2.6	3.3	3.6	V
V _{BAT}	Battery supply voltage	—	1.8	—	3.6	V

(1) Based on characterization, not tested in production.

Figure 4-1. Recommended power supply decoupling capacitors⁽¹⁾⁽²⁾

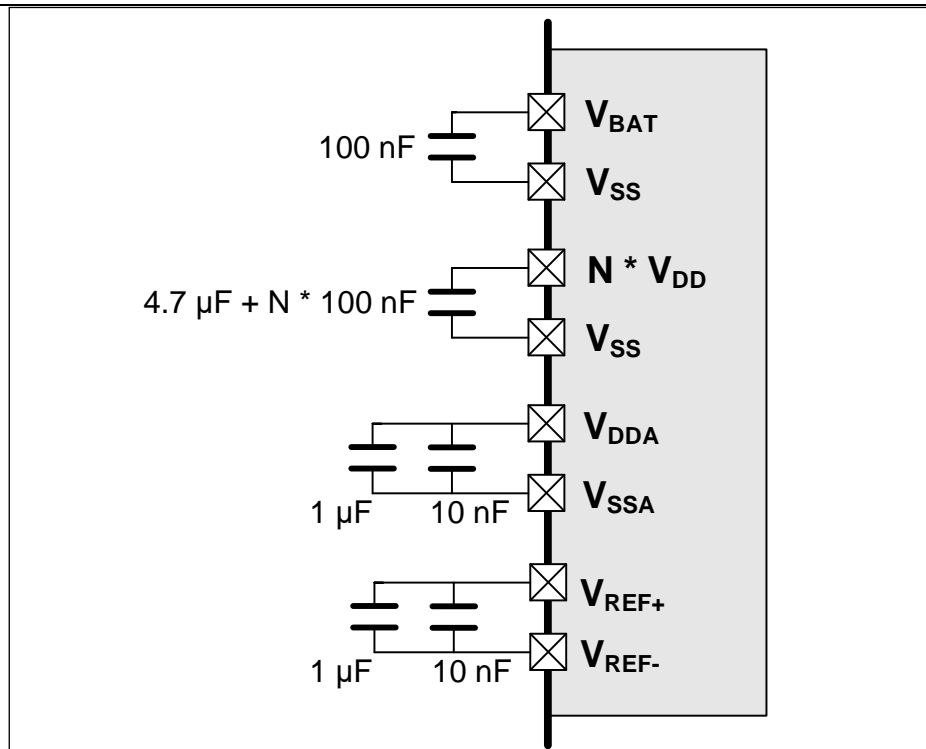

- (1) The V_{REF+} and V_{REF-} pins are only available on no less than 100-pin packages, or else the V_{REF+} and V_{REF-} pins are not available and internally connected to V_{DDA} and V_{SSA} pins.
- (2) All decoupling capacitors need to be as close as possible to the pins on the PCB board.

Table 4-3. Clock frequency⁽¹⁾

Symbol	Parameter	Conditions	Min	Max	Unit
f_{HCLK}	AHB clock frequency	—	—	108	MHz
f_{APB1}	APB1 clock frequency	—	—	54	MHz
f_{APB2}	APB2 clock frequency	—	—	108	MHz

- (1) Guaranteed by design, not tested in production.

Table 4-4. Operating conditions at Power up/ Power down⁽¹⁾

Symbol	Parameter	Conditions	Min	Max	Unit
t_{VDD}	V_{DD} rise time rate	—	0	∞	$\mu\text{s}/\text{V}$
	V_{DD} fall time rate		20	∞	

- (1) Guaranteed by design, not tested in production.

Table 4-5. Start-up timings of Operating conditions⁽¹⁾⁽²⁾⁽³⁾

Symbol	Parameter	Conditions	Typ	Unit
$t_{start-up}$	Start-up time	Clock source from HXTAL	132	ms
		Clock source from IRC8M	132	

- (1) Based on characterization, not tested in production.
- (2) After power-up, the start-up time is the time between the rising edge of NRST high and the main function.
- (3) PLL is off.

Table 4-6. Power saving mode wakeup timings characteristics⁽¹⁾⁽²⁾

Symbol	Parameter	Typ	Unit
t_{Sleep}	Wakeup from Sleep mode	4.5	μs
$t_{\text{Deep-sleep}}$	Wakeup from Deep-sleep mode (LDO On)	6	
	Wakeup from Deep-sleep mode (LDO in low power mode)	6	
t_{Standby}	Wakeup from Standby mode	119	ms

(1) Based on characterization, not tested in production.

(2) The wakeup time is measured from the wakeup event to the point at which the application code reads the first instruction under the below conditions: $V_{\text{DD}} = V_{\text{DDA}} = 3.3\text{ V}$, IRC8M = System clock = 8 MHz.

4.3. Power consumption

The power measurements specified in the tables represent that code with data executing from on-chip Flash with the following specifications.

Table 4-7. Power consumption characteristics⁽²⁾⁽³⁾⁽⁴⁾⁽⁵⁾

Symbol	Parameter	Conditions	Min	Typ ⁽¹⁾	Max	Unit
$I_{\text{DD}}+I_{\text{DDA}}$	Supply current (Run mode)	$V_{\text{DD}} = V_{\text{DDA}} = 3.3\text{ V}$, HXTAL = 8 MHz, System clock = 108 MHz, All peripherals enabled	—	63.8	—	mA
		$V_{\text{DD}} = V_{\text{DDA}} = 3.3\text{ V}$, HXTAL = 8 MHz, System clock = 108 MHz, All peripherals disabled	—	37.6	—	mA
		$V_{\text{DD}} = V_{\text{DDA}} = 3.3\text{ V}$, HXTAL = 8 MHz, System clock = 96 MHz, All peripherals enabled	—	57.1	—	mA
		$V_{\text{DD}} = V_{\text{DDA}} = 3.3\text{ V}$, HXTAL = 8 MHz, System clock = 96 MHz, All peripherals disabled	—	33.8	—	mA
		$V_{\text{DD}} = V_{\text{DDA}} = 3.3\text{ V}$, HXTAL = 8 MHz, System clock = 72 MHz, All peripherals enabled	—	43.6	—	mA
		$V_{\text{DD}} = V_{\text{DDA}} = 3.3\text{ V}$, HXTAL = 8 MHz, System clock = 72 MHz, All peripherals disabled	—	26.2	—	mA
		$V_{\text{DD}} = V_{\text{DDA}} = 3.3\text{ V}$, HXTAL = 8 MHz, System clock = 48 MHz, All peripherals enabled	—	30.2	—	mA
		$V_{\text{DD}} = V_{\text{DDA}} = 3.3\text{ V}$, HXTAL = 8 MHz, System clock = 48 MHz, All peripherals disabled	—	18.6	—	mA
		$V_{\text{DD}} = V_{\text{DDA}} = 3.3\text{ V}$, HXTAL = 8 MHz, System clock = 36 MHz, All peripherals enabled	—	23.4	—	mA



Symbol	Parameter	Conditions	Min	Typ ⁽¹⁾	Max	Unit
		V _{DD} = V _{DDA} = 3.3 V, HXTAL = 8 MHz, System clock = 36 MHz, All peripherals disabled	—	14.8	—	mA
		V _{DD} = V _{DDA} = 3.3 V, HXTAL = 8 MHz, System clock = 24 MHz, All peripherals enabled	—	16.7	—	mA
		V _{DD} = V _{DDA} = 3.3 V, HXTAL = 8 MHz, System clock = 24 MHz, All peripherals disabled	—	10.9	—	mA
		V _{DD} = V _{DDA} = 3.3 V, HXTAL = 8 MHz, System clock = 16 MHz, All peripherals enabled	—	12.1	—	mA
		V _{DD} = V _{DDA} = 3.3 V, HXTAL = 8 MHz, System clock = 16 MHz, All peripherals disabled	—	8	—	mA
		V _{DD} = V _{DDA} = 3.3 V, HXTAL = 8 MHz, System clock = 8 MHz, All peripherals enabled	—	7.4	—	mA
		V _{DD} = V _{DDA} = 3.3 V, HXTAL = 8 MHz, System clock = 8 MHz, All peripherals disabled	—	5.4	—	mA
	Supply current (Sleep mode)	V _{DD} = V _{DDA} = 3.3 V, HXTAL = 8 MHz, System Clock = 108 MHz, CPU clock off, All peripherals enabled	—	38.7	—	mA
		V _{DD} = V _{DDA} = 3.3 V, HXTAL = 8 MHz, System Clock = 108 MHz, CPU clock off, All peripherals disabled	—	9.1	—	mA
		V _{DD} = V _{DDA} = 3.3 V, HXTAL = 8 MHz, System Clock = 96 MHz, CPU clock off, All peripherals enabled	—	34.7	—	mA
		V _{DD} = V _{DDA} = 3.3 V, HXTAL = 8 MHz, System Clock = 96 MHz, CPU clock off, All peripherals disabled	—	8.4	—	mA
		V _{DD} = V _{DDA} = 3.3 V, HXTAL = 8 MHz, System Clock = 72 MHz, CPU clock off, All peripherals enabled	—	26.9	—	mA
		V _{DD} = V _{DDA} = 3.3 V, HXTAL = 8 MHz, System Clock = 72 MHz, CPU clock off, All peripherals disabled	—	6.7	—	mA
		V _{DD} = V _{DDA} = 3.3 V, HXTAL = 8 MHz, System Clock = 48 MHz, CPU clock off, All peripherals enabled	—	18.6	—	mA



Symbol	Parameter	Conditions	Min	Typ ⁽¹⁾	Max	Unit
		V _{DD} = V _{DDA} = 3.3 V, HXTAL = 8 MHz, System Clock = 48 MHz, CPU clock off, All peripherals disabled	—	5.5	—	mA
		V _{DD} = V _{DDA} = 3.3 V, HXTAL = 8 MHz, System Clock = 36 MHz, CPU clock off, All peripherals enabled	—	14.7	—	mA
		V _{DD} = V _{DDA} = 3.3 V, HXTAL = 8 MHz, System Clock = 36 MHz, CPU clock off, All peripherals disabled	—	4.8	—	mA
		V _{DD} = V _{DDA} = 3.3 V, HXTAL = 8 MHz, System Clock = 24 MHz, CPU clock off, All peripherals enabled	—	10.8	—	mA
		V _{DD} = V _{DDA} = 3.3 V, HXTAL = 8 MHz, System Clock = 24 MHz, CPU clock off, All peripherals disabled	—	4.2	—	mA
		V _{DD} = V _{DDA} = 3.3 V, HXTAL = 8 MHz, System Clock = 16 MHz, CPU clock off, All peripherals enabled	—	8.1	—	mA
		V _{DD} = V _{DDA} = 3.3 V, HXTAL = 8 MHz, System Clock = 16 MHz, CPU clock off, All peripherals disabled	—	3.7	—	mA
		V _{DD} = V _{DDA} = 3.3 V, HXTAL = 8 MHz, System Clock = 8 MHz, CPU clock off, All peripherals enabled	—	5.5	—	mA
		V _{DD} = V _{DDA} = 3.3 V, HXTAL = 8 MHz, System Clock = 8 MHz, CPU clock off, All peripherals disabled	—	3.3	—	mA
	Supply current (Deep-Sleep mode)	V _{DD} = V _{DDA} = 3.3 V, LDO in normal power mode, IRC40K off, RTC off, All GPIOs analog mode	—	585	—	μA
		V _{DD} = V _{DDA} = 3.3 V, LDO in low power mode, IRC40K off, RTC off, All GPIOs analog mode	—	573	—	μA
	Supply current (Standby mode)	V _{DD} = V _{DDA} = 3.3 V, LXTAL off, IRC40K on, RTC on	—	7.8	—	μA
		V _{DD} = V _{DDA} = 3.3 V, LXTAL off, IRC40K on, RTC off	—	7.4	—	μA
		V _{DD} = V _{DDA} = 3.3 V, LXTAL off, IRC40K off, RTC off	—	6.2	—	μA
I _{BAT}		V _{DD} off, V _{DDA} off, V _{BAT} = 3.6 V, LXTAL on with external crystal, RTC on	—	16.6	—	μA

Symbol	Parameter	Conditions	Min	Typ ⁽¹⁾	Max	Unit
	Battery supply current (Backup mode)	V _{DD} off, V _{DDA} off, V _{BAT} = 3.3 V, LXTAL on with external crystal, RTC on	—	12.6	—	μA
		V _{DD} off, V _{DDA} off, V _{BAT} = 2.6 V, LXTAL on with external crystal, RTC on	—	5.9	—	μA
		V _{DD} off, V _{DDA} off, V _{BAT} = 1.8 V, LXTAL on with external crystal, RTC on	—	2	—	μA

- (1) Based on characterization, not tested in production.
- (2) Unless otherwise specified, all values given for T_A = 25 °C and test result is mean value.
- (3) When System Clock is less than 4 MHz, an external source is used, and the HXTAL bypass function is needed, no PLL.
- (4) When System Clock is greater than 8 MHz, a crystal 8 MHz is used, and the HXTAL bypass function is closed, using PLL.
- (5) When analog peripheral blocks such as ADCs, DACs, HXTAL, LXTAL, IRC8M, or IRC40K are ON, an additional power consumption should be considered.

Figure 4-2. Typical supply current consumption in Run mode

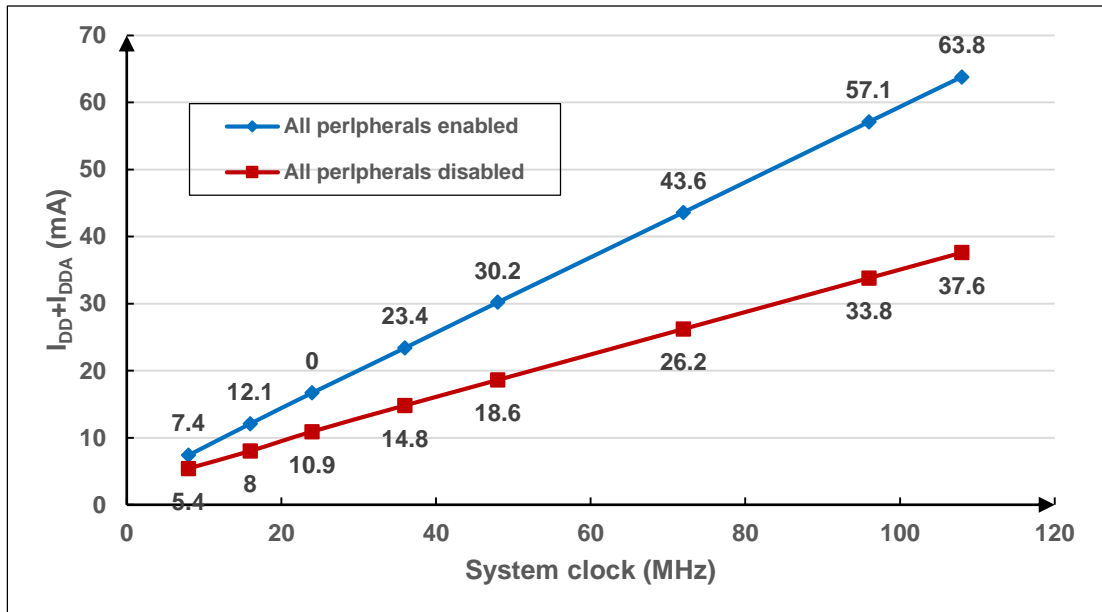
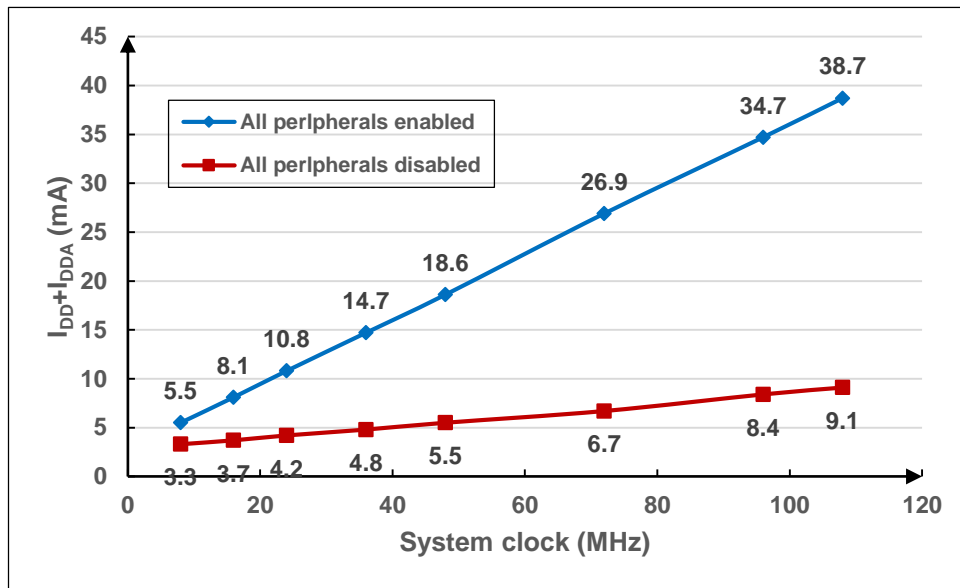

Figure 4-3. Typical supply current consumption in Sleep mode



4.4. EMC characteristics

EMS (electromagnetic susceptibility) includes ESD (Electrostatic discharge, positive and negative) and FTB (Burst of Fast Transient voltage, positive and negative) testing result is given in [Table 4-8. EMS characteristics](#), based on the EMS levels and classes compliant with IEC 61000 series standard.

Table 4-8. EMS characteristics⁽¹⁾

Symbol	Parameter	Conditions	Level/Class
V _{ESD}	Voltage applied to all device pins to induce a functional disturbance	V _{DD} = 3.3 V, T _A = 25 °C LQFP144, f _{HCLK} = 108 MHz conforms to IEC 61000-4-2	3B
V _{FTB}	Fast transient voltage burst applied to induce a functional disturbance through 100 pF on V _{DD} and V _{SS} pins	V _{DD} = 3.3 V, T _A = 25 °C LQFP144, f _{HCLK} = 108 MHz conforms to IEC 61000-4-4	4A

(1) Based on characterization, not tested in production.

4.5. Power supply supervisor characteristics

Table 4-9. Power supply supervisor characteristics

Symbol	Parameter	Conditions	Min	Typ	Max	Unit
V _{LVD} ⁽¹⁾	Low voltage Detector level selection	LVDT<2:0> = 000(rising edge)	—	2.19	—	V
		LVDT<2:0> = 000(falling edge)	—	2.08	—	
		LVDT<2:0> = 001(rising edge)	—	2.29	—	



Symbol	Parameter	Conditions	Min	Typ	Max	Unit
		LVDT<2:0> = 001(falling edge)	—	2.19	—	
		LVDT<2:0> = 010(rising edge)	—	2.39	—	
		LVDT<2:0> = 010(falling edge)	—	2.29	—	
		LVDT<2:0> = 011(rising edge)	—	2.5	—	
		LVDT<2:0> = 011(falling edge)	—	2.39	—	
		LVDT<2:0> = 100(rising edge)	—	2.6	—	
		LVDT<2:0> = 100(falling edge)	—	2.48	—	
		LVDT<2:0> = 101(rising edge)	—	2.68	—	
		LVDT<2:0> = 101(falling edge)	—	2.58	—	
		LVDT<2:0> = 110(rising edge)	—	2.79	—	
		LVDT<2:0> = 110(falling edge)	—	2.68	—	
		LVDT<2:0> = 111(rising edge)	—	2.89	—	
		LVDT<2:0> = 111(falling edge)	—	2.78	—	
V _{LVdhyst} ⁽²⁾	LVD hysteresis	—	—	100	—	mV
V _{POR} ⁽¹⁾	Power on reset threshold	—	—	2.40	—	V
V _{PDR} ⁽¹⁾	Power down reset threshold		—	1.85	—	V
V _{PDRhyst} ⁽²⁾	PDR hysteresis		—	550	—	mV
t _{RSTTEMPO} ⁽²⁾	Reset temporization		—	2	—	ms

(1) Based on characterization, not tested in production.

(2) Guaranteed by design, not tested in production.

4.6. Electrical sensitivity

The device is strained in order to determine its performance in terms of electrical sensitivity. Electrostatic discharges (ESD) are applied directly to the pins of the sample. Static latch-up (LU) test is based on the two measurement methods.

Table 4-10. ESD characteristics⁽¹⁾

Symbol	Parameter	Conditions	Min	Typ	Max	Unit
V _{ESD(HBM)}	Electrostatic discharge voltage (human body model)	T _A =25 °C; JS-001-2014	—	—	3000	V
V _{ESD(CDM)}	Electrostatic discharge voltage (charge device model)	T _A =25 °C; JS-002-2014	—	—	500	V

(1) Based on characterization, not tested in production.

Table 4-11. Static latch-up characteristics⁽¹⁾

Symbol	Parameter	Conditions	Min	Typ	Max	Unit
LU	I-test	T _A =25 °C; JESD78	—	—	±100	mA
	V _{supply} over voltage		—	—	5.4	V

(1) Based on characterization, not tested in production.

4.7. External clock characteristics

Table 4-12. High speed external clock (HXTAL) generated from a crystal/ceramic characteristics

Symbol	Parameter	Conditions	Min	Typ	Max	Unit
f _{HXTAL} ⁽¹⁾	Crystal or ceramic frequency	2.6 V ≤ V _{DD} ≤ 3.6 V	3	8	25	MHz
R _F ⁽²⁾	Feedback resistor	V _{DD} = 3.3 V	—	400	—	kΩ
C _{HXTAL} ⁽²⁾⁽³⁾	Recommended load capacitance on OSCIN and OSCOUT	—	—	20	30	pF
D _{ucy} (HXTAL) ⁽²⁾	Crystal or ceramic duty cycle	—	30	50	70	%
g _m ⁽²⁾	Oscillator transconductance	Startup	—	35	—	mA/V
I _{DDHXTAL} ⁽¹⁾	Crystal or ceramic operating current	V _{DD} = 3.3 V, T _A = 25 °C	—	1.6	—	mA
t _{SUHXTAL} ⁽¹⁾	Crystal or ceramic startup time	V _{DD} = 3.3 V, T _A = 25 °C	—	0.65	—	ms

(1) Based on characterization, not tested in production.

(2) Guaranteed by design, not tested in production.

(3) C_{HXTAL1} = C_{HXTAL2} = 2*(C_{LOAD} - C_S). For C_{HXTAL1} and C_{HXTAL2}, it is recommended matching capacitance on OSCIN and OSCOUT. For C_{LOAD}, it is crystal/ceramic load capacitance, provided by the crystal or ceramic manufacturer. For C_S, it is PCB and MCU pin stray capacitance.

Table 4-13. High speed external clock characteristics (HXTAL in bypass mode)

Symbol	Parameter	Conditions	Min	Typ	Max	Unit
f _{HXTAL_ext} ⁽¹⁾	External clock source or oscillator frequency	2.6 V ≤ V _{DD} ≤ 3.6 V	1	—	50	MHz
V _{HXTALH} ⁽²⁾	OSCIN input pin high level voltage	V _{DD} = 3.3 V	0.7 V _{DD}	—	V _{DD}	V
V _{HXTALL} ⁽²⁾	OSCIN input pin low level voltage		V _{SS}	—	0.3 V _{DD}	V
t _{H/L} (HXTAL) ⁽²⁾	OSCIN high or low time	—	5	—	—	ns
t _{R/F} (HXTAL) ⁽²⁾	OSCIN rise or fall time	—	—	—	10	ns
C _{IN} ⁽²⁾	OSCIN input capacitance	—	—	5	—	pF
D _{ucy} (HXTAL) ⁽²⁾	Duty cycle	—	40	—	60	%

(1) Based on characterization, not tested in production.

(2) Guaranteed by design, not tested in production.

Table 4-14. Low speed external clock (LXTAL) generated from a crystal/ceramic characteristics

Symbol	Parameter	Conditions	Min	Typ	Max	Unit
$f_{LXTAL}^{(1)}$	Crystal or ceramic frequency	$V_{DD} = 3.3 V$	—	32.768	—	kHz
$C_{LXTAL}^{(2)(3)}$	Recommended matching capacitance on OSC32IN and OSC32OUT	—	—	10	—	pF
$Ducy_{(LXTAL)}^{(2)}$	Crystal or ceramic duty cycle	—	30	—	70	%
$g_m^{(2)}$	Oscillator transconductance	—	—	11	—	$\mu A/V$
$I_{DDLXTAL}^{(1)}$	Crystal or ceramic operating current	—	—	11.6	—	μA
$t_{SULXTAL}^{(1)(4)}$	Crystal or ceramic startup time	—	—	0.39	—	s

(1) Based on characterization, not tested in production.

(2) Guaranteed by design, not tested in production.

(3) $C_{LXTAL1} = C_{LXTAL2} = 2 * (C_{LOAD} - C_S)$, For C_{LXTAL1} and C_{LXTAL2} , it is recommended matching capacitance on OSC32IN and OSC32OUT. For C_{LOAD} , it is crystal/ceramic load capacitance, provided by the crystal or ceramic manufacturer. For C_S , it is PCB and MCU pin stray capacitance.

(4) $t_{SULXTAL}$ is the startup time measured from the moment it is enabled (by software) to the 32.768 kHz oscillator stabilization flags is SET. This value varies significantly with the crystal manufacturer.

Table 4-15. Low speed external user clock characteristics (LXTAL in bypass mode)

Symbol	Parameter	Conditions	Min	Typ	Max	Unit
$f_{LXTAL_ext}^{(1)}$	External clock source or oscillator frequency	$V_{DD} = 3.3 V$	—	32.768	1000	kHz
$V_{LXTALH}^{(2)}$	OSC32IN input pin high level voltage	—	$0.7 V_{DD}$	—	V_{DD}	V
$V_{LXTALL}^{(2)}$	OSC32IN input pin low level voltage	—	V_{SS}	—	$0.3 V_{DD}$	
$t_{H/L(LXTAL)}^{(2)}$	OSC32IN high or low time	—	450	—	—	ns
$t_{R/F(LXTAL)}^{(2)}$	OSC32IN rise or fall time	—	—	—	50	
$C_{IN}^{(2)}$	OSC32IN input capacitance	—	—	5	—	pF
$Ducy_{(LXTAL)}^{(2)}$	Duty cycle	—	30	50	70	%

(1) Based on characterization, not tested in production.

(2) Guaranteed by design, not tested in production.

4.8. Internal clock characteristics

Table 4-16. High speed internal clock (IRC8M) characteristics

Symbol	Parameter	Conditions	Min	Typ	Max	Unit
f_{IRC8M}	High Speed Internal Oscillator (IRC8M) frequency	$V_{DD} = V_{DDA} = 3.3\text{ V}$	—	8	—	MHz
ACC_{IRC8M}	IRC8M oscillator Frequency accuracy, Factory-trimmed	$V_{DD} = V_{DDA} = 3.3\text{ V}$, $T_A = -40\text{ °C} \sim +85\text{ °C}^{(1)}$	-2.5	—	2.5	%
		$V_{DD} = V_{DDA} = 3.3\text{ V}$, $T_A = 25\text{ °C}$	-1.0	—	+1.0	%
	IRC8M oscillator Frequency accuracy, User trimming step ⁽¹⁾	—	—	0.5	—	%
$DUCY_{IRC8M}^{(2)}$	IRC8M oscillator duty cycle	$V_{DD} = V_{DDA} = 3.3\text{ V}$	45	50	55	%
$I_{DDAIRC8M}^{(1)}$	IRC8M oscillator operating current	$V_{DD} = V_{DDA} = 3.3\text{ V}$, $T_A = 25\text{ °C}$	—	62	—	μA
$t_{SUIRC8M}^{(1)}$	IRC8M oscillator startup time	$V_{DD} = V_{DDA} = 3.3\text{ V}$, $T_A = 25\text{ °C}$	—	0.64	—	μs

(1) Based on characterization, not tested in production.

(2) Guaranteed by design, not tested in production.

Table 4-17. Low speed internal clock (IRC40K) characteristics

Symbol	Parameter	Conditions	Min	Typ	Max	Unit
$f_{IRC40K}^{(1)}$	Low Speed Internal oscillator (IRC40K) frequency	$V_{DD} = V_{DDA} = 3.3\text{ V}$, $T_A = -40\text{ °C} \sim +85\text{ °C}$	—	40	—	kHz
$I_{DDAIRC40K}^{(2)}$	IRC40K oscillator operating current	$V_{DD} = V_{DDA} = 3.3\text{ V}$, $T_A = 25\text{ °C}$	—	1.2	—	μA
$t_{SUIRC40K}^{(2)}$	IRC40K oscillator startup time	$V_{DD} = V_{DDA} = 3.3\text{ V}$, $T_A = 25\text{ °C}$	—	124	—	μs

(1) Guaranteed by design, not tested in production.

(2) Based on characterization, not tested in production.

4.9. PLL characteristics

Table 4-18. PLL characteristics

Symbol	Parameter	Conditions	Min	Typ	Max	Unit
$f_{PLLIN}^{(1)}$	PLL input clock frequency	—	1	—	25	MHz
$f_{PLLOUT}^{(2)}$	PLL output clock frequency	—	16	—	108	MHz
$f_{VCO}^{(2)}$	PLL VCO output clock frequency	—	32	—	216	MHz
$t_{LOCK}^{(2)}$	PLL lock time	—	—	—	300	μs

(1) Based on characterization, not tested in production.

(2) Guaranteed by design, not tested in production.

Table 4-19. PLL1 characteristics

Symbol	Parameter	Conditions	Min	Typ	Max	Unit
$f_{\text{PLLIN}}^{(1)}$	PLL input clock frequency	—	1	—	25	MHz
$f_{\text{PLOWT}}^{(2)}$	PLL output clock frequency	—	16	—	120	MHz
$f_{\text{VCO}}^{(2)}$	PLL VCO output clock frequency	—	32	—	200	MHz
$t_{\text{LOCK}}^{(2)}$	PLL lock time	—	—	—	300	μs

(1) Based on characterization, not tested in production.

(2) Guaranteed by design, not tested in production.

Table 4-20. PLL2 characteristics

Symbol	Parameter	Conditions	Min	Typ	Max	Unit
$f_{\text{PLLIN}}^{(1)}$	PLL input clock frequency	—	1	—	25	MHz
$f_{\text{PLOWT}}^{(2)}$	PLL output clock frequency	—	16	—	120	MHz
$f_{\text{VCO}}^{(2)}$	PLL VCO output clock frequency	—	32	—	200	MHz
$t_{\text{LOCK}}^{(2)}$	PLL lock time	—	—	—	300	μs

(1) Based on characterization, not tested in production.

(2) Guaranteed by design, not tested in production.

4.10. Memory characteristics

Table 4-21. Flash memory characteristics

Symbol	Parameter	Conditions	Min ⁽¹⁾	Typ ⁽¹⁾	Max ⁽²⁾	Unit
PE_{CYC}	Number of guaranteed program /erase cycles before failure (Endurance)	$T_A = -40\text{ }^\circ\text{C} \sim +85\text{ }^\circ\text{C}$	100	—	—	kcycles
t_{RET}	Data retention time	—	—	20	—	years
t_{PROG}	Word programming time	$T_A = -40\text{ }^\circ\text{C} \sim +85\text{ }^\circ\text{C}$	—	37.5	105/170 ⁽³⁾	μs
t_{ERASE}	Page erase time	$T_A = -40\text{ }^\circ\text{C} \sim +85\text{ }^\circ\text{C}$	—	50	400/500 ⁽⁴⁾	ms
$t_{\text{MERASE(64K)}}$	Mass erase time	$T_A = -40\text{ }^\circ\text{C} \sim +85\text{ }^\circ\text{C}$	—	0.6	6	s
$t_{\text{MERASE(128K)}}$	Mass erase time	$T_A = -40\text{ }^\circ\text{C} \sim +85\text{ }^\circ\text{C}$	—	1.2	12	s
$t_{\text{MERASE(256K)}}$	Mass erase time	$T_A = -40\text{ }^\circ\text{C} \sim +85\text{ }^\circ\text{C}$	—	2.4	24	s
$t_{\text{MERASE(512K)}}$	Mass erase time	$T_A = -40\text{ }^\circ\text{C} \sim +85\text{ }^\circ\text{C}$	—	8	64	s
$t_{\text{MERASE(1MB)}}$	Mass erase time	$T_A = -40\text{ }^\circ\text{C} \sim +85\text{ }^\circ\text{C}$	—	16	128	s

(1) Based on characterization, not tested in production.

(2) Guaranteed by design, not tested in production.

(3) Flash memory $\leq 256\text{K}$ is 105 μs and flash memory $>256\text{K}$ is 170 μs .

(4) Flash memory $\leq 256\text{K}$ is 400 ms and flash memory $>256\text{K}$ is 500 ms.

4.11. NRST pin characteristics

Table 4-22. NRST pin characteristics

Symbol	Parameter	Conditions	Min	Typ	Max	Unit
$V_{IL(NRST)}^{(1)}$	NRST Input low level voltage	$V_{DD} = V_{DDA} = 2.6\text{ V}$	-0.3	—	$0.3 V_{DD}$	V
$V_{IH(NRST)}^{(1)}$	NRST Input high level voltage		$0.7 V_{DD}$	—	$V_{DD} + 0.3$	
$V_{hyst}^{(1)}$	Schmidt trigger Voltage hysteresis		—	350	—	mV
$V_{IL(NRST)}^{(1)}$	NRST Input low level voltage	$V_{DD} = V_{DDA} = 3.3\text{ V}$	-0.3	—	$0.3 V_{DD}$	V
$V_{IH(NRST)}^{(1)}$	NRST Input high level voltage		$0.7 V_{DD}$	—	$V_{DD} + 0.3$	
$V_{hyst}^{(1)}$	Schmidt trigger Voltage hysteresis		—	360	—	mV
$V_{IL(NRST)}^{(1)}$	NRST Input low level voltage	$V_{DD} = V_{DDA} = 3.6\text{ V}$	-0.3	—	$0.3 V_{DD}$	V
$V_{IH(NRST)}^{(1)}$	NRST Input high level voltage		$0.7 V_{DD}$	—	$V_{DD} + 0.3$	
$V_{hyst}^{(1)}$	Schmidt trigger Voltage hysteresis		—	370	—	mV
$R_{pu}^{(2)}$	Pull-up equivalent resistor	—	—	40	—	k Ω

(1) Based on characterization, not tested in production.

(2) Guaranteed by design, not tested in production.

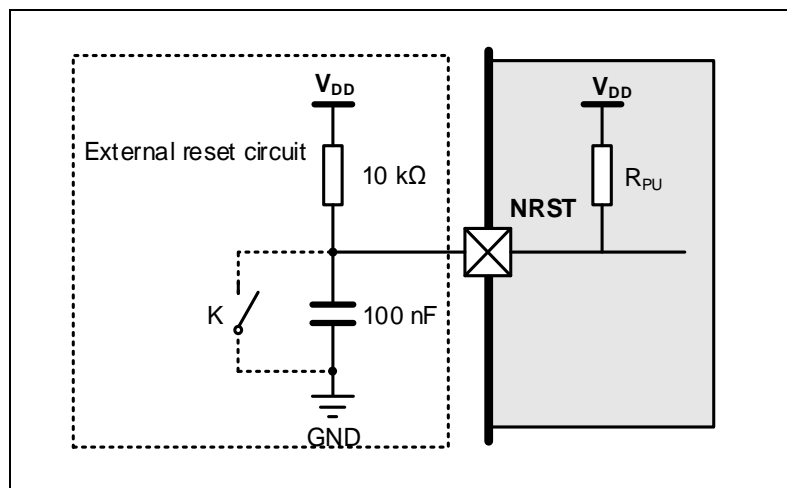
Figure 4-4. Recommended external NRST pin circuit⁽¹⁾

(1) Unless the voltage on NRST pin go below $V_{IL(NRST)}$ level, the device would not generate a reliable reset.

4.12. GPIO characteristics

Table 4-23. I/O port DC characteristics⁽¹⁾⁽³⁾

Symbol	Parameter	Conditions	Min	Typ	Max	Unit
V_{IL}	Standard IO Low level input voltage	$2.6\text{ V} \leq V_{DD} = V_{DDA} \leq 3.6\text{ V}$	—	—	$0.3 V_{DD}$	V
	5V-tolerant IO Low level input voltage	$2.6\text{ V} \leq V_{DD} = V_{DDA} \leq 3.6\text{ V}$	—	—	$0.3 V_{DD}$	V
V_{IH}	Standard IO Low level input voltage	$2.6\text{ V} \leq V_{DD} = V_{DDA} \leq 3.6\text{ V}$	$0.7 V_{DD}$	—	—	V
	5V-tolerant IO Low level	$2.6\text{ V} \leq V_{DD} = V_{DDA} \leq 3.6\text{ V}$	$0.7 V_{DD}$	—	—	V



Symbol	Parameter	Conditions	Min	Typ	Max	Unit	
	input voltage						
R _{PU} (2)	Internal pull-up resistor	All pins	V _{IN} = V _{SS}	—	40	—	kΩ
		PA10	—	—	10	—	
R _{PD} (2)	Internal pull-down resistor	All pins	V _{IN} = V _{DD}	—	40	—	kΩ
		PA10	—	—	10	—	
IO_Speed=50MHz							
V _{OL}	Low level output voltage for an IO Pin (I _{IO} = +8 mA)	V _{DD} = 2.6V	—	0.27	—	V	
		V _{DD} = 3.3 V	—	0.23	—		
		V _{DD} = 3.6V	—	0.22	—		
	Low level output voltage for an IO Pin (I _{IO} = +12mA)	V _{DD} = 2.6V	—	0.43	—		
		V _{DD} = 3.3 V	—	0.66	—		
	Low level output voltage for an IO Pin (I _{IO} = +20 mA)	V _{DD} = 3.6V	—	0.61	—		
V _{OH}	High level output voltage for an IO Pin (I _{IO} = +8 mA)	V _{DD} = 2.6V	—	2.3	—	V	
		V _{DD} = 3.3 V	—	3.05	—		
		V _{DD} = 3.6V	—	3.36	—		
	High level output voltage for an IO Pin (I _{IO} = +10 mA)	V _{DD} = 2.6V	—	2.21	—		
		V _{DD} = 3.3 V	—	2.59	—		
	High level output voltage for an IO Pin (I _{IO} = +20 mA)	V _{DD} = 3.6V	—	2.95	—		
IO_Speed=10MHz							
V _{OL}	Low level output voltage for an IO Pin (I _{IO} = +8 mA)	V _{DD} = 2.6V	—	0.43	—	V	
		V _{DD} = 3.3 V	—	0.36	—		
		V _{DD} = 3.6V	—	0.34	—		
	Low level output voltage for an IO Pin (I _{IO} = +15 mA)	V _{DD} = 2.6V	—	—	—		
		V _{DD} = 3.3 V	—	0.78	—		
	V _{DD} = 3.6V	—	0.72	—			
V _{OH}	High level output voltage for an IO Pin (I _{IO} = +8 mA)	V _{DD} = 2.6V	—	2.06	—	V	
		V _{DD} = 3.3 V	—	2.87	—		
		V _{DD} = 3.6V	—	3.2	—		
	High level output voltage for an IO Pin (I _{IO} = +15mA)	V _{DD} = 2.6V	—	—	—		
		V _{DD} = 3.3 V	—	2.39	—		
	V _{DD} = 3.6V	—	2.77	—			
IO_Speed=2MHz							
V _{OL}	Low level output voltage for an IO Pin (I _{IO} = +4 mA)	V _{DD} = 2.6V	—	0.44	—	V	
		V _{DD} = 3.3 V	—	0.36	—		
		V _{DD} = 3.6V	—	0.34	—		



Symbol	Parameter	Conditions	Min	Typ	Max	Unit
V _{OH}	High level output voltage for an IO Pin (I _{IO} = +4mA)	V _{DD} = 2.6V	—	2.22	—	V
		V _{DD} = 3.3 V	—	2.99	—	
		V _{DD} = 3.6V	—	3.31	—	

- (1) Based on characterization, not tested in production.
- (2) Guaranteed by design, not tested in production.
- (3) All pins except PC13 / PC14 / PC15. Since PC13 to PC15 are supplied through the Power Switch, which can only be obtained by a small current, the speed of GPIOs PC13 to PC15 should not exceed 2 MHz when they are in output mode(maximum load: 30 pF).

Table 4-24. I/O port AC characteristics⁽¹⁾⁽²⁾⁽⁴⁾

GPIOx_MDy[1:0] bit value ⁽³⁾	Parameter	Conditions	Typ	Unit
GPIOx_CTL->MDy[1:0]=10 (IO_Speed = 2MHz)	T _{Rise} /T _{Fall}	2.6 ≤ V _{DD} ≤ 3.6 V, C _L = 10 pF	49.2	ns
		2.6 ≤ V _{DD} ≤ 3.6 V, C _L = 30 pF	60	
		2.6 ≤ V _{DD} ≤ 3.6 V, C _L = 50 pF	70.4	
GPIOx_CTL->MDy[1:0] = 01 (IO_Speed = 10MHz)	T _{Rise} /T _{Fall}	2.6 ≤ V _{DD} ≤ 3.6 V, C _L = 10 pF	23.4	ns
		2.6 ≤ V _{DD} ≤ 3.6 V, C _L = 30 pF	27	
		2.6 ≤ V _{DD} ≤ 3.6 V, C _L = 50 pF	32	
GPIOx_CTL->MDy[1:0]=11 (IO_Speed = 50MHz)	T _{Rise} /T _{Fall}	2.6 ≤ V _{DD} ≤ 3.6 V, C _L = 10 pF	3.3	ns
		2.6 ≤ V _{DD} ≤ 3.6 V, C _L = 30 pF	3.5	
		2.6 ≤ V _{DD} ≤ 3.6 V, C _L = 50 pF	3.6	

- (1) Based on characterization, not tested in production.
- (2) Unless otherwise specified, all test results given for T_A = 25 °C.
- (3) The I/O speed is configured using the GPIOx_CTL -> MDy[1:0] bits.
- (4) Only for reference, Depending on user's design.

4.13. Temperature sensor characteristics

Table 4-25. Temperature sensor characteristics⁽¹⁾

Symbol	Parameter	Min	Typ	Max	Unit
T _L	VSENSE linearity with temperature	—	±1.5	—	°C
Avg_Slope	Average slope	—	4.1	—	mV/°C
V ₂₅	Voltage at 25 °C	—	1.45	—	V
t _{S_temp} ⁽²⁾	ADC sampling time when reading the temperature	—	17.1	—	µs

- (1) Based on characterization, not tested in production.
- (2) Shortest sampling time can be determined in the application by multiple iterations.

4.14. ADC characteristics

Table 4-26. ADC characteristics

Symbol	Parameter	Conditions	Min	Typ	Max	Unit
V _{DDA} ⁽¹⁾	Operating voltage	—	2.6	3.3	3.6	V
V _{IN} ⁽¹⁾	ADC input voltage range	16 external; 2 internal	0	—	V _{REF+}	V
V _{REF+} ⁽²⁾	Positive Reference Voltage	—	2.6	—	V _{DDA}	V



Symbol	Parameter	Conditions	Min	Typ	Max	Unit
V _{REF-} (²)	Negative Reference Voltage	—	—	V _{SSA}	—	V
f _{ADC} (¹)	ADC clock	—	0.6	—	14	MHz
f _s (¹)	Sampling rate	12-bit	0.04	—	1	MSPS
R _{AIN} (²)	External input impedance	See Equation 1	—	—	219.8	kΩ
R _{ADC} (²)	Input sampling switch resistance	—	—	—	0.5	kΩ
C _{ADC} (²)	Input sampling capacitance	No pin/pad capacitance included	—	—	8	pF
t _{CAL} (²)	Calibration time	f _{ADC} = 14 MHz	—	7.28	—	μs
t _s (²)	Sampling time	f _{ADC} = 14 MHz	0.11	—	17.11	μs
t _{CONV} (²)	Total conversion time(including sampling time)	12-bit	—	14	—	1/f _{ADC}
t _{SU} (²)	Startup time	—	—	—	1	μs

(1) Based on characterization, not tested in production.

(2) Guaranteed by design, not tested in production.

Equation 1: R_{AIN max} formula $R_{AIN} < \frac{T_s}{f_{ADC} * C_{ADC} * \ln(2^{N+2})} - R_{ADC}$

The formula above ([Equation 1](#)) is used to determine the maximum external impedance allowed for an error below 1/4 of LSB. Here N = 12 (from 12-bit resolution).

Table 4-27. ADC R_{AIN max} for f_{ADC} = 14 MHz

T _s (cycles)	t _s (μs)	R _{AIN max} (kΩ)
1.5	0.11	0.8
7.5	0.54	6.4
13.5	0.96	11.9
28.5	2.04	25.7
41.5	2.96	37.6
55.5	3.96	50.5
71.5	5.11	65.2
239.5	17.11	219.8

4.15. DAC characteristics

Table 4-28. DAC characteristics

Symbol	Parameter	Conditions	Min	Typ	Max	Unit
V _{DDA} (¹)	Operating voltage	—	2.6	3.3	3.6	V
V _{REF+} (²)	Positive Reference Voltage	—	2.6	—	V _{DDA}	V



Symbol	Parameter	Conditions	Min	Typ	Max	Unit
$V_{REF-}^{(2)}$	Negative Reference Voltage	—	—	V_{SSA}	—	V
$R_{LOAD}^{(2)}$	Load resistance	Resistive load with buffer ON	5	—	—	k Ω
$R_o^{(2)}$	Impedance output with buffer OFF	—	—	—	15	k Ω
$C_{LOAD}^{(2)}$	Load capacitance	No pin/pad capacitance included	—	—	50	pF
DAC_OUT min ⁽²⁾	Lower DAC_OUT voltage with buffer ON	—	0.2	—	—	V
DAC_OUT max ⁽²⁾	Higher DAC_OUT voltage with buffer ON	—	—	—	$V_{DDA}-0.2$	V
DAC_OUT min ⁽²⁾	Lower DAC_OUT voltage with buffer OFF	—	—	0.5	—	mV
DAC_OUT max ⁽²⁾	Higher DAC_OUT voltage with buffer OFF	—	—	—	$V_{DDA}-1LSB$	V
$I_{DDA}^{(1)}$	DAC current consumption in quiescent mode	With no load, middle code(0x800) on the input, $V_{REF+} = 3.6$ V	—	550	—	μ A
		With no load, worst code(0xF1C) on the input, $V_{REF+} = 3.6$ V	—	600	—	μ A
$I_{DDVREF+}^{(1)}$	DAC current consumption in quiescent mode	With no load, middle code(0x800) on the input, $V_{REF+} = 3.6$ V	—	86	—	μ A
		With no load, worst code(0xF1C) on the input, $V_{REF+} = 3.6$ V	—	298	—	μ A
$T_{setting}^{(1)}$	Settling time	$C_{LOAD} \leq 50$ pF, $R_{LOAD} \geq 5$ k Ω	—	0.3	1	μ s
$T_{wakeup}^{(2)}$	Wakeup from off state	—	—	5	10	μ s
Update rate ⁽²⁾	Max frequency for a correct DAC_OUT change from code i to $i \pm 1LSBs$	$C_{LOAD} \leq 50$ pF, $R_{LOAD} \geq 5$ k Ω	—	—	4	MS/s
PSRR ⁽²⁾	Power supply rejection ratio (to V_{DDA})	—	55	80	—	dB

(1) Based on characterization, not tested in production.

(2) Guaranteed by design, not tested in production.

4.16. I2C characteristics

Table 4-29. I2C characteristics⁽¹⁾⁽²⁾⁽³⁾

Symbol	Parameter	Conditions	Standard mode		Fast mode		Unit
			Min	Max	Min	Max	
$t_{SCL(H)}$	SCL clock high time	—	4.0	—	0.6	—	μ s

Symbol	Parameter	Conditions	Standard mode		Fast mode		Unit
			Min	Max	Min	Max	
$t_{SCL(L)}$	SCL clock low time	—	4.7	—	1.3	—	μs
$t_{su(SDA)}$	SDA setup time	—	250	—	100	—	ns
$t_h(SDA)$	SDA data hold time	—	0 ⁽³⁾	3450	0	900	ns
$t_r(SDA/SCL)$	SDA and SCL rise time	—	—	1000	—	300	ns
$t_f(SDA/SCL)$	SDA and SCL fall time	—	—	300	—	300	ns
$t_h(STA)$	Start condition hold time	—	4.0	—	0.6	—	μs
$t_s(STA)$	Repeated Start condition setup time	—	4.7	—	0.6	—	μs
$t_s(STO)$	Stop condition setup time	—	4.0	—	0.6	—	μs
t_{buff}	Stop to Start condition time (bus free)	—	4.7	—	1.3	—	μs

- (1) Guaranteed by design, not tested in production.
 (2) To ensure the standard mode I2C frequency, f_{PCLK1} must be at least 2 MHz. To ensure the fast mode I2C frequency, f_{PCLK1} must be at least 4 MHz.
 (3) The device should provide a data hold time of 300 ns at least in order to bridge the undefined region of the falling edge of SCL.

Figure 4-5. I2C bus timing diagram

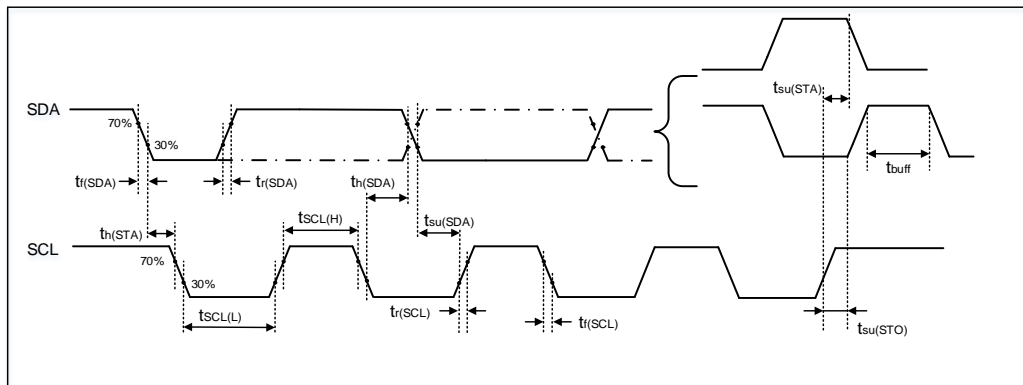

4.17. SPI characteristics

Table 4-30. Standard SPI characteristics⁽¹⁾

Symbol	Parameter	Conditions	Min	Typ	Max	Unit
f_{SCK}	SCK clock frequency	—	—	—	27	MHz
$t_{SCK(H)}$	SCK clock high time	Master mode, $f_{PCLKx} = 108 \text{ MHz}$, presc = 4	35.13	37.13	39.13	ns
$t_{SCK(L)}$	SCK clock low time	Master mode, $f_{PCLKx} = 108 \text{ MHz}$, presc = 4	35.13	37.13	39.13	ns
SPI master mode						
$t_{v(MO)}$	Data output valid time	—	—	—	8	ns



$t_{SU(MI)}$	Data input setup time	—	1	—	—	ns
$t_{H(MI)}$	Data input hold time	—	0	—	—	ns
SPI slave mode						
$t_{SU(NSS)}$	NSS enable setup time	—	0	—	—	ns
$t_{H(NSS)}$	NSS enable hold time	—	1	—	—	ns
$t_{A(SO)}$	Data output access time	—	—	9	—	ns
$t_{DIS(SO)}$	Data output disable time	—	—	11	—	ns
$t_{V(SO)}$	Data output valid time	—	—	11	—	ns
$t_{SU(SI)}$	Data input setup time	—	0	—	—	ns
$t_{H(SI)}$	Data input hold time	—	1	—	—	ns

(1) Based on characterization, not tested in production.

Figure 4-6. SPI timing diagram - master mode

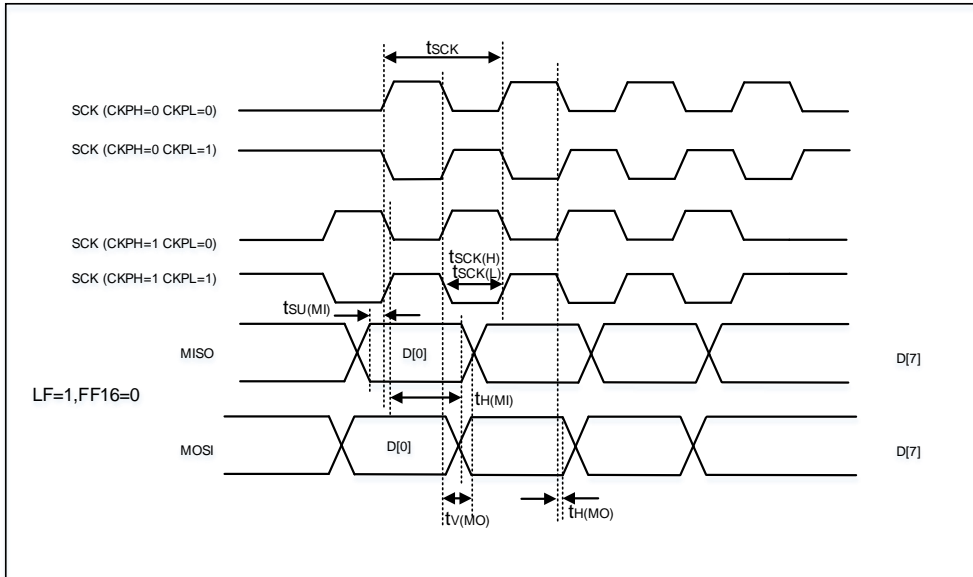
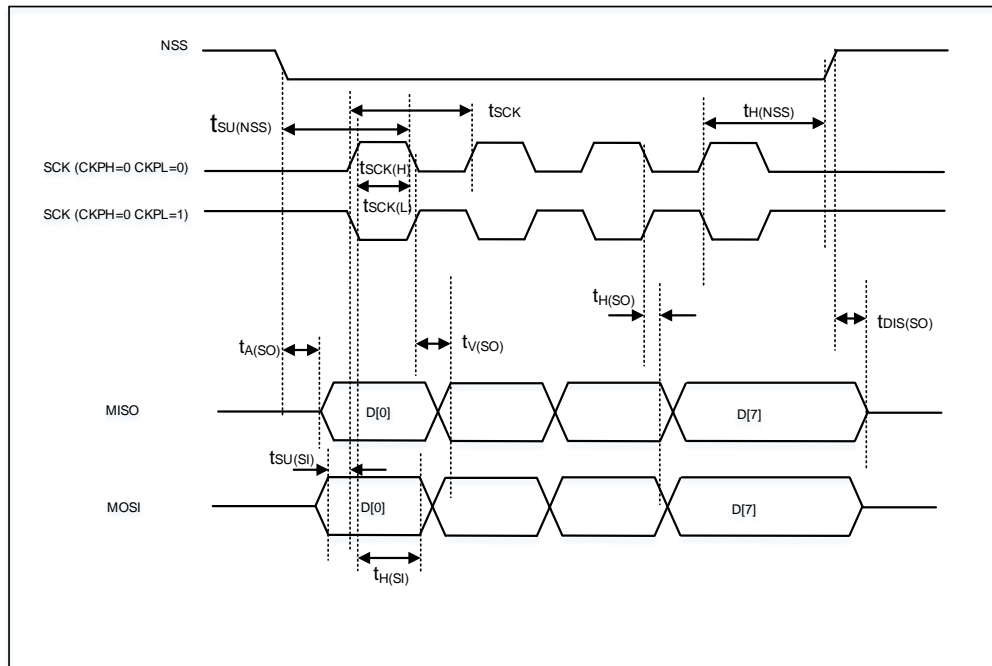

Figure 4-7. SPI timing diagram - slave mode



4.18. I2S characteristics

Table 4-31. I2S characteristics⁽¹⁾⁽²⁾

Symbol	Parameter	Conditions	Min	Typ	Max	Unit
f_{CK}	Clock frequency	Master mode (data: 32 bits, Audio frequency = 96 kHz)	—	6.25	—	MHz
		Slave mode	0	—	12.5	
t_H	Clock high time	—	—	80	—	ns
t_L	Clock low time		—	80	—	ns
$t_{V(WS)}$	WS valid time	Master mode	—	3	—	ns
$t_{H(WS)}$	WS hold time	Master mode	—	3	—	ns
$t_{SU(WS)}$	WS setup time	Slave mode	0	—	—	ns
$t_{H(WS)}$	WS hold time	Slave mode	2	—	—	ns
$Ducy(SCK)$	I2S slave input clock duty cycle	Slave mode	—	50	—	%
$t_{SU(SD_MR)}$	Data input setup time	Master mode	1	—	—	ns
$t_{SU(SD_SR)}$	Data input setup time	Slave mode	0	—	—	ns
$t_{H(SD_MR)}$	Data input hold time	Master receiver	0	—	—	ns
$t_{H(SD_SR)}$		Slave receiver	1	—	—	ns
$t_{V(SD_ST)}$	Data output valid time	Slave transmitter (after enable edge)	—	—	5	ns
$t_{H(SD_ST)}$	Data output hold time	Slave transmitter	6	—	—	ns

Symbol	Parameter	Conditions	Min	Typ	Max	Unit
		(after enable edge)				
$t_{V(SD_MT)}$	Data output valid time	Master transmitter (after enable edge)	—	—	5	ns
$t_{H(SD_MT)}$	Data output hold time	Master transmitter (after enable edge)	0	—	—	ns

- (1) Guaranteed by design, not tested in production.
 (2) Based on characterization, not tested in production

Figure 4-8. I2S timing diagram - master mode

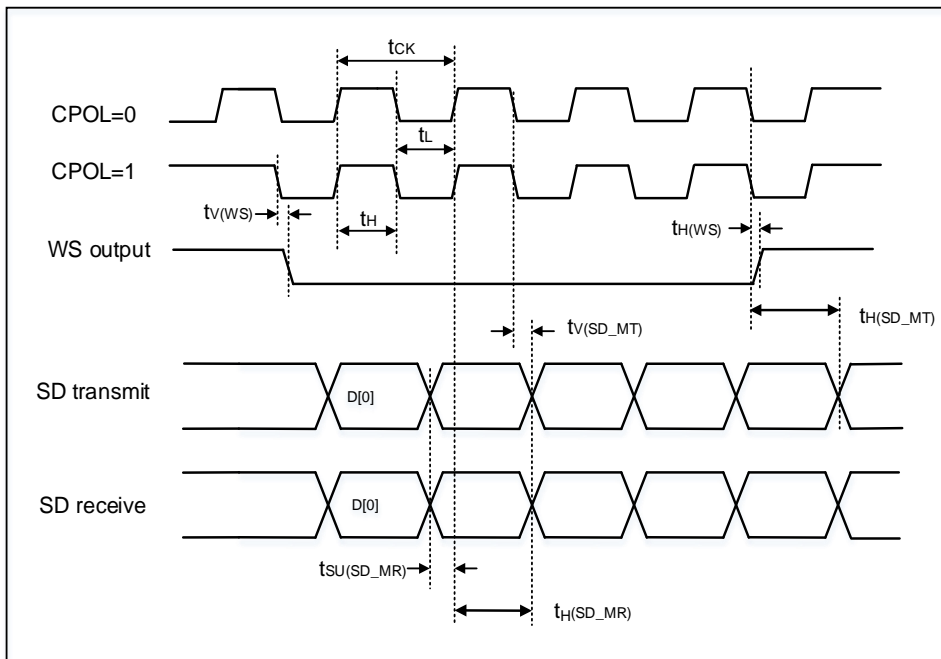
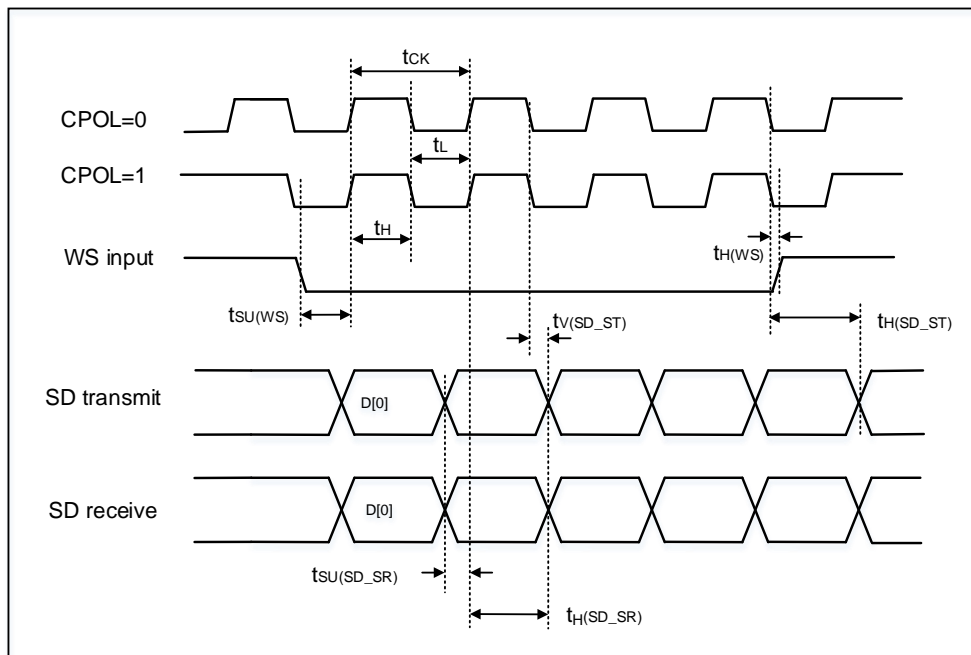

Figure 4-9. I2S timing diagram - slave mode



4.19. USART characteristics

Table 4-32. USART characteristics⁽¹⁾

Symbol	Parameter	Conditions	Min	Typ	Max	Unit
f_{SCK}	SCK clock frequency	$f_{PCLKx} = 108 \text{ MHz}$	—	—	13.5	MHz
$t_{SCK(H)}$	SCK clock high time	$f_{PCLKx} = 108 \text{ MHz}$	37.0	—	—	ns
$t_{SCK(L)}$	SCK clock low time	$f_{PCLKx} = 108 \text{ MHz}$	37.0	—	—	ns

(1) Guaranteed by design, not tested in production.

4.20. CAN characteristics

Refer to [Table 4-23. I/O port DC characteristics^{\(1\)}](#) for more details on the input/output alternate function characteristics (CANTX and CANRX).

4.21. USBFS characteristics

Table 4-33. USBFS start up time

Symbol	Parameter	Max	Unit
$t_{STARTUP}^{(1)}$	USBFS startup time	1	μs

(1) Guaranteed by design, not tested in production.

Table 4-34. USBFS DC electrical characteristics

Symbol	Parameter	Conditions	Min	Typ	Max	Unit	
Input levels ⁽¹⁾	V _{DD}	USBFS operating voltage	—	3	—	3.6	V
	V _{DI}	Differential input sensitivity	—	0.2	—	—	
	V _{CM}	Differential common mode range	Includes V _{DI} range	0.8	—	2.5	
	V _{SE}	Single ended receiver threshold	—	0.8	—	2.0	
Output levels ⁽²⁾	V _{OL}	Static output level low	R _L of 1.0 kΩ to 3.6 V	—	0.064	0.3	V
	V _{OH}	Static output level high	R _L of 15 kΩ to V _{SS}	2.8	3.3	3.6	
R _{PD} ⁽²⁾	PA11, PA12(USB_DM/DP)	V _{IN} = V _{DD}	17	20.574	24	kΩ	
	PA9(USB_VBUS)		0.65	—	2.0		
R _{PU} ⁽²⁾	PA11, PA12(USB_DM/DP)	V _{IN} = V _{SS}	1.5	1.585	2.1		
	PA9(USB_VBUS)		0.25	0.326	0.55		

(1) Guaranteed by design, not tested in production.

(2) Based on characterization, not tested in production.

Table 4-35. USBFS full speed-electrical characteristics⁽¹⁾

Symbol	Parameter	Conditions	Min	Typ	Max	Unit
t _R	Rise time	CL = 50 pF	4	—	20	ns
t _F	Fall time	CL = 50 pF	4	—	20	ns
t _{RFM}	Rise/fall time matching	t _R / t _F	90	—	110	%
V _{CRS}	Output signal crossover voltage	—	1.3	—	2.0	V

(1) Guaranteed by design, not tested in production.

Figure 4-10. USBFS timings: definition of data signal rise and fall time

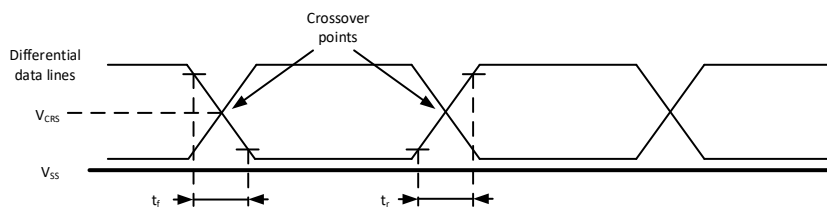

4.22. EXMC characteristics

Table 4-36. Synchronous multiplexed PSRAM/NOR read timings⁽¹⁾⁽²⁾⁽³⁾

Symbol	Parameter	Min	Max	Unit
t _w (CLK)	EXMC_CLK period	36.8	—	ns
t _d (CLKL-NEXL)	EXMC_CLK low to EXMC_NEx low	0	—	ns
t _d (CLKH-NEXH)	EXMC_CLK high to EXMC_NEx high	18.4	—	ns
t _d (CLKL-NADV _L)	EXMC_CLK low to EXMC_NADV low	0	—	ns
t _d (CLKL-NADV _H)	EXMC_CLK low to EXMC_NADV high	0	—	ns
t _d (CLKL-AV)	EXMC_CLK low to EXMC_Ax valid	0	—	ns

Symbol	Parameter	Min	Max	Unit
$t_{d(CLKH-AIV)}$	EXMC_CLK high to EXMC_Ax invalid	18.4	—	ns
$t_{d(CLKL-NOEL)}$	EXMC_CLK low to EXMC_NOE low	0	—	ns
$t_{d(CLKH-NOEH)}$	EXMC_CLK high to EXMC_NOE high	18.4	—	ns
$t_{d(CLKL-ADV)}$	EXMC_CLK low to EXMC_AD valid	0	—	ns
$t_{d(CLKL-ADIV)}$	EXMC_CLK low to EXMC_AD invalid	0	—	ns

(1) $C_L = 30$ pF.

(2) Guaranteed by design, not tested in production.

(3) Based on configure: $f_{HCLK} = 108$ MHz, BurstAccessMode = Enable; Memory Type = PSRAM; WriteBurst = Enable; CLKDivision = 3 (EXMC_CLK is 4 divided by HCLK); Data Latency = 1.

Table 4-37. Synchronous multiplexed PSRAM write timings⁽¹⁾⁽²⁾⁽³⁾

Symbol	Parameter	Min	Max	Unit
$t_w(CLK)$	EXMC_CLK period	36.8	—	ns
$t_{d(CLKL-NExL)}$	EXMC_CLK low to EXMC_NEx low	0	—	ns
$t_{d(CLKH-NExH)}$	EXMC_CLK high to EXMC_NEx high	18.4	—	ns
$t_{d(CLKL-NADV L)}$	EXMC_CLK low to EXMC_NADV low	0	—	ns
$t_{d(CLKL-NADV H)}$	EXMC_CLK low to EXMC_NADV high	0	—	ns
$t_{d(CLKL-AV)}$	EXMC_CLK low to EXMC_Ax valid	0	—	ns
$t_{d(CLKH-AIV)}$	EXMC_CLK high to EXMC_Ax invalid	18.4	—	ns
$t_{d(CLKL-NWEL)}$	EXMC_CLK low to EXMC_NWE low	0	—	ns
$t_{d(CLKH-NWEH)}$	EXMC_CLK high to EXMC_NWE high	18.4	—	ns
$t_{d(CLKL-ADIV)}$	EXMC_CLK low to EXMC_AD invalid	0	—	ns
$t_{d(CLKL-DATA)}$	EXMC_A/D valid data after EXMC_CLK low	0	—	ns
$t_h(CLKL-NBLH)$	EXMC_CLK low to EXMC_NBL high	0	—	ns

(1) $C_L = 30$ pF.

(2) Guaranteed by design, not tested in production.

(3) Based on configure: $f_{HCLK} = 108$ MHz, BurstAccessMode = Enable; MemoryType = PSRAM; WriteBurst = Enable; CLKDivision = 3 (EXMC_CLK is 4 divided by HCLK); DataLatency = 1.

Table 4-38. Synchronous non-multiplexed PSRAM/NOR read timings⁽¹⁾⁽²⁾⁽³⁾

Symbol	Parameter	Min	Max	Unit
$t_w(CLK)$	EXMC_CLK period	36.8	—	ns
$t_{d(CLKL-NExL)}$	EXMC_CLK low to EXMC_NEx low	0	—	ns
$t_{d(CLKH-NExH)}$	EXMC_CLK high to EXMC_NEx high	18.4	—	ns
$t_{d(CLKL-NADV L)}$	EXMC_CLK low to EXMC_NADV low	0	—	ns
$t_{d(CLKL-NADV H)}$	EXMC_CLK low to EXMC_NADV high	0	—	ns
$t_{d(CLKL-AV)}$	EXMC_CLK low to EXMC_Ax valid	0	—	ns
$t_{d(CLKH-AIV)}$	EXMC_CLK high to EXMC_Ax invalid	18.4	—	ns
$t_{d(CLKL-NOEL)}$	EXMC_CLK low to EXMC_NOE low	0	—	ns
$t_{d(CLKH-NOEH)}$	EXMC_CLK high to EXMC_NOE high	18.4	—	ns

(1) $C_L = 30$ pF.

(2) Guaranteed by design, not tested in production.

(3) Based on configure: HCLK=108 MHz, BurstAccessMode = Enable; MemoryType = PSRAM; WriteBurst = Enable; CLKDivision = 3 (EXMC_CLK is 4 divided by HCLK); DataLatency = 1.

Table 4-39. Synchronous non-multiplexed PSRAM write timings⁽¹⁾⁽²⁾⁽³⁾

Symbol	Parameter	Min	Max	Unit
$t_{w(\text{CLK})}$	EXMC_CLK period	36.8	—	ns
$t_{d(\text{CLKL-NExL})}$	EXMC_CLK low to EXMC_NEx low	0	—	ns
$t_{d(\text{CLKH-NExH})}$	EXMC_CLK high to EXMC_NEx high	18.4	—	ns
$t_{d(\text{CLKL-NADVl})}$	EXMC_CLK low to EXMC_NADV low	0	—	ns
$t_{d(\text{CLKL-NADVh})}$	EXMC_CLK low to EXMC_NADV high	0	—	ns
$t_{d(\text{CLKL-AV})}$	EXMC_CLK low to EXMC_Ax valid	0	—	ns
$t_{d(\text{CLKH-AIV})}$	EXMC_CLK high to EXMC_Ax invalid	18.4	—	ns
$t_{d(\text{CLKL-NWEL})}$	EXMC_CLK low to EXMC_NWE low	0	—	ns
$t_{d(\text{CLKH-NWEH})}$	EXMC_CLK high to EXMC_NWE high	18.4	—	ns
$t_{d(\text{CLKL-DATA})}$	EXMC_A/D valid data after EXMC_CLK low	0	—	ns
$t_{h(\text{CLKL-NBLH})}$	EXMC_CLK low to EXMC_NBL high	0	—	ns

(1) $C_L = 30$ pF.

(2) Guaranteed by design, not tested in production.

(3) Based on configure: HCLK = 108 MHz, BurstAccessMode = Enable; MemoryType = PSRAM; WriteBurst = Enable; CLKDivision = 3 (EXMC_CLK is 4 divided by HCLK); DataLatency = 1.

4.23. TIMER characteristics

Table 4-40. TIMER characteristics⁽¹⁾

Symbol	Parameter	Conditions	Min	Max	Unit
t_{res}	Timer resolution time	—	1	—	$t_{\text{TIMERxCLK}}$
		$f_{\text{TIMERxCLK}} = 108$ MHz	9.3	—	ns
f_{EXT}	Timer external clock frequency	—	0	$f_{\text{TIMERxCLK}}/2$	MHz
		$f_{\text{TIMERxCLK}} = 108$ MHz	0	54	MHz
RES	Timer resolution	—	—	16	bit
t_{COUNTER}	16-bit counter clock period when internal clock is selected	—	1	65536	$t_{\text{TIMERxCLK}}$
		$f_{\text{TIMERxCLK}} = 108$ MHz	0.0093	607	μs
$t_{\text{MAX_COUNT}}$	Maximum possible count	—	—	65536×65536	$t_{\text{TIMERxCLK}}$
		$f_{\text{TIMERxCLK}} = 108$ MHz	—	39.8	s

(1) Guaranteed by design, not tested in production.

4.24. WDGT characteristics

Table 4-41. FWDGT min/max timeout period at 40 kHz (IRC40K)⁽¹⁾

Prescaler divider	PR[2:0] bits	Min timeout RLD[11:0] = 0x000	Max timeout RLD[11:0] = 0xFFFF	Unit
1/4	000	0.025	409.525	ms
1/8	001	0.025	819.025	
1/16	010	0.025	1638.025	
1/32	011	0.025	3276.025	



Prescaler divider	PR[2:0] bits	Min timeout RLD[11:0] = 0x000	Max timeout RLD[11:0] = 0xFFF	Unit
1/64	100	0.025	6552.025	
1/128	101	0.025	13104.025	
1/256	110 or 111	0.025	26208.025	

(1) Guaranteed by design, not tested in production.

Table 4-42. WWDGT min-max timeout value at 54 MHz (f_{PCLK1})⁽¹⁾

Prescaler divider	PSC[2:0]	Min timeout value CNT[6:0] = 0x40	Unit	Max timeout value CNT[6:0] = 0x7F	Unit
1/1	00	75.8	μs	4.8	ms
1/2	01	151.7		9.7	
1/4	10	303.4		19.4	
1/8	11	606.8		38.8	

(1) Guaranteed by design, not tested in production.

4.25. Parameter condition

Unless otherwise specified, all values given for $V_{DD} = V_{DDA} = 3.3\text{ V}$, $T_A = 25\text{ }^\circ\text{C}$.

5. Package information

5.1. LQFP144 package outline dimensions

Figure 5-1. LQFP144 package outline

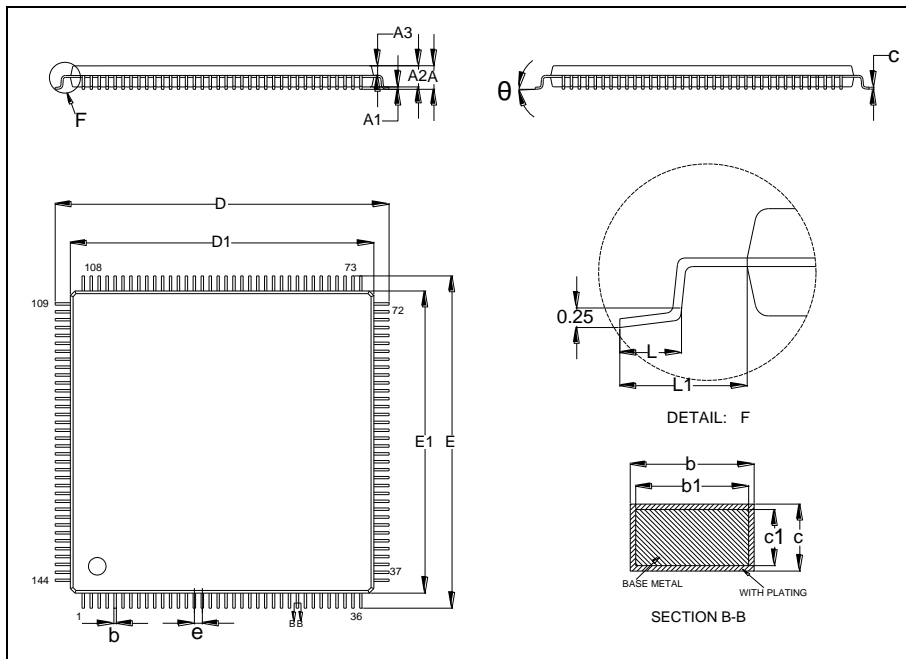
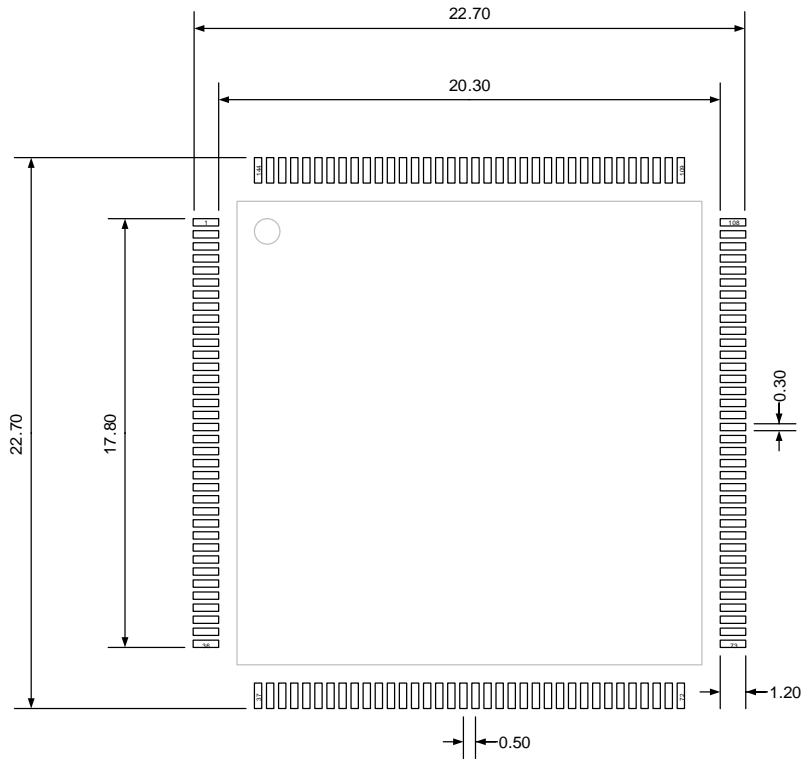

Table 5-1. LQFP144 package dimensions

Symbol	Min	Typ	Max
A	—	—	1.60
A1	0.05	—	0.15
A2	1.35	1.40	1.45
A3	0.59	0.64	0.69
b	0.18	—	0.26
b1	0.17	0.20	0.23
c	0.13	—	0.17
c1	0.12	0.13	0.14
D	21.80	22.00	22.20
D1	19.90	20.00	20.10
E	21.80	22.00	22.20
E1	19.90	20.00	20.10
e	—	0.50	—
L	0.45	—	0.75
L1	—	1.00	—
θ	0°	—	7°

(Original dimensions are in millimeters)

Figure 5-2. LQFP144 recommended footprint



(Original dimensions are in millimeters)

5.2. LQFP100 package outline dimensions

Figure 5-3. LQFP100 package outline

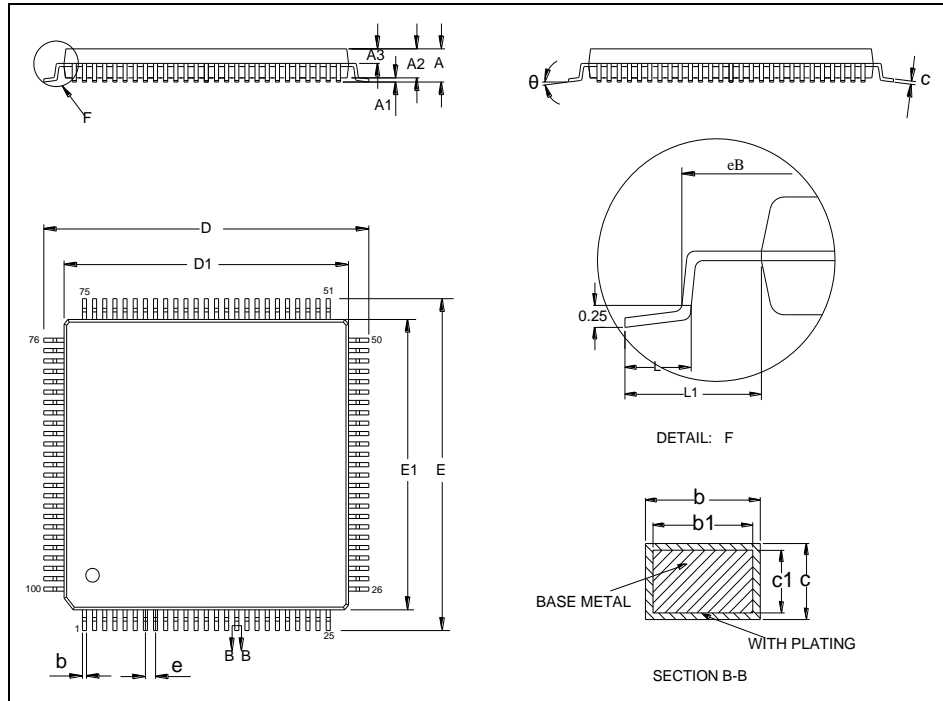
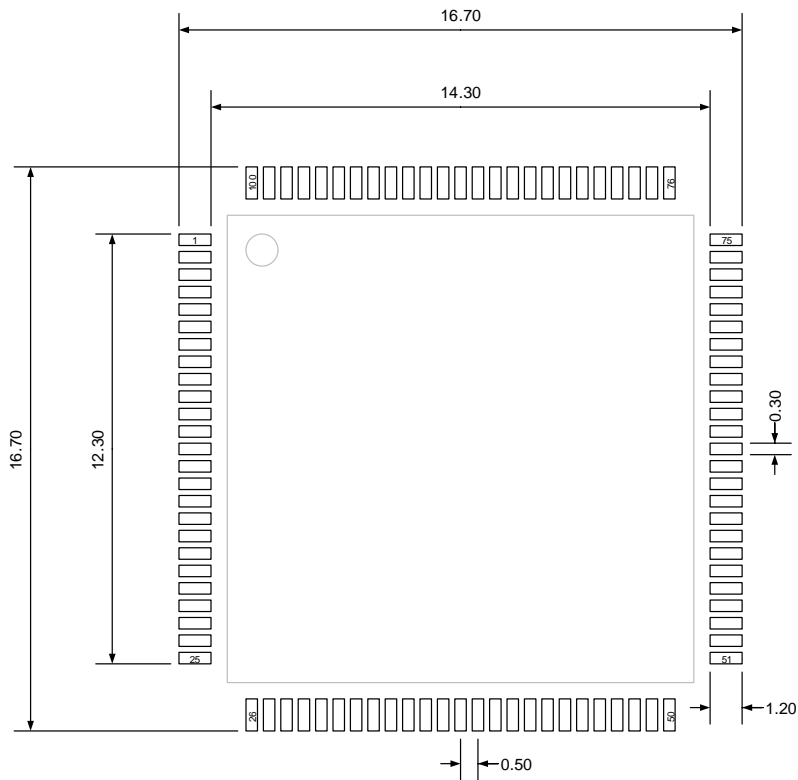

Table 5-2. LQFP100 package dimensions

Symbol	Min	Typ	Max
A	—	—	1.60
A1	0.05	—	0.15
A2	1.35	1.40	1.45
A3	0.59	0.64	0.69
b	0.18	—	0.26
b1	0.17	0.20	0.23
c	0.13	—	0.17
c1	0.12	0.13	0.14
D	15.80	16.00	16.20
D1	13.90	14.00	14.10
E	15.80	16.00	16.20
E1	13.90	14.00	14.10
e	—	0.50	—
eB	15.05	—	15.35
L	0.45	—	0.75
L1	—	1.00	—
θ	0°	—	7°

(Original dimensions are in millimeters)

Figure 5-4. LQFP100 recommended footprint



(Original dimensions are in millimeters)

5.3. LQFP64 package outline dimensions

Figure 5-5. LQFP64 package outline

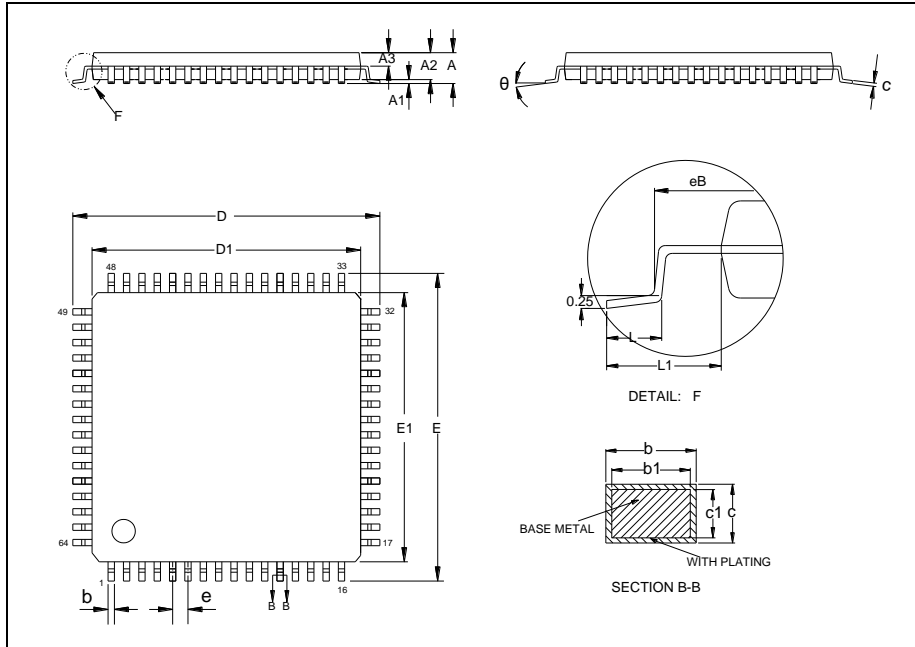
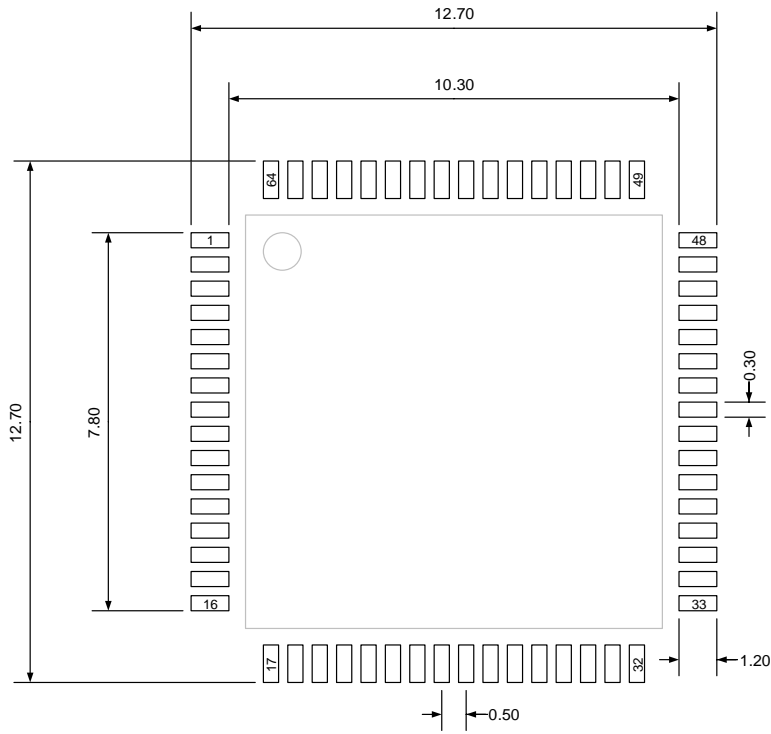

Table 5-3. LQFP64 package dimensions

Symbol	Min	Typ	Max
A	—	—	1.60
A1	0.05	—	0.15
A2	1.35	1.40	1.45
A3	0.59	0.64	0.69
b	0.18	—	0.26
b1	0.17	0.20	0.23
c	0.13	—	0.17
c1	0.12	0.13	0.14
D	11.80	12.00	12.20
D1	9.90	10.00	10.10
E	11.80	12.00	12.20
E1	9.90	10.00	10.10
e	—	0.50	—
eB	11.25	—	11.45
L	0.45	—	0.75
L1	—	1.00	—
θ	0°	—	7°

(Original dimensions are in millimeters)

Figure 5-6. LQFP64 recommended footprint



(Original dimensions are in millimeters)

5.4. Thermal characteristics

Thermal resistance is used to characterize the thermal performance of the package device, which is represented by the Greek letter “ θ ”. For semiconductor devices, thermal resistance represents the steady-state temperature rise of the chip junction due to the heat dissipated on the chip surface.

θ_{JA} : Thermal resistance, junction-to-ambient.

θ_{JB} : Thermal resistance, junction-to-board.

θ_{JC} : Thermal resistance, junction-to-case.

Ψ_{JB} : Thermal characterization parameter, junction-to-board.

Ψ_{JT} : Thermal characterization parameter, junction-to-top center.

$$\theta_{JA}=(T_J-T_A)/P_D \quad (5-1)$$

$$\theta_{JB}=(T_J-T_B)/P_D \quad (5-2)$$

$$\theta_{JC}=(T_J-T_C)/P_D \quad (5-3)$$

Where, T_J = Junction temperature.

T_A = Ambient temperature

T_B = Board temperature

T_C = Case temperature which is monitoring on package surface

P_D = Total power dissipation

θ_{JA} represents the resistance of the heat flows from the heating junction to ambient air. It is an indicator of package heat dissipation capability. Lower θ_{JA} can be considerate as better overall thermal performance. θ_{JA} is generally used to estimate junction temperature.

θ_{JB} is used to measure the heat flow resistance between the chip surface and the PCB board.

θ_{JC} represents the thermal resistance between the chip surface and the package top case. θ_{JC} is mainly used to estimate the heat dissipation of the system (using heat sink or other heat dissipation methods outside the device package).

Table 5-4. Package thermal characteristics⁽¹⁾

Symbol	Condition	Package	Value	Unit
θ_{JA}	Natural convection, 2S2P PCB	LQFP144	48.76	°C/W
		LQFP100	57.42	
		LQFP64	61.80	
θ_{JB}	Cold plate, 2S2P PCB	LQFP144	35.00	°C/W
		LQFP100	31.68	
		LQFP64	42.83	



Symbol	Condition	Package	Value	Unit
θ_{JC}	Cold plate, 2S2P PCB	LQFP144	12.03	°C/W
		LQFP100	13.85	
		LQFP64	21.98	
ψ_{JB}	Natural convection, 2S2P PCB	LQFP144	35.32	°C/W
		LQFP100	41.28	
		LQFP64	43.05	
ψ_{JT}	Natural convection, 2S2P PCB	LQFP144	1.86	°C/W
		LQFP100	0.75	
		LQFP64	1.58	

(1) Thermal characteristics are based on simulation, and meet JEDEC specification.

6. Ordering information

Table 6-1. Part ordering code for GD32F107xx devices

Ordering code	Flash (KB)	Package	Package type	Temperature operating range
GD32F107ZGT6	1024	LQFP144	Green	Industrial -40°C to +85°C
GD32F107ZFT6	768	LQFP144	Green	Industrial -40°C to +85°C
GD32F107ZET6	512	LQFP144	Green	Industrial -40°C to +85°C
GD32F107ZDT6	384	LQFP144	Green	Industrial -40°C to +85°C
GD32F107ZCT6	256	LQFP144	Green	Industrial -40°C to +85°C
GD32F107VGT6	1024	LQFP100	Green	Industrial -40°C to +85°C
GD32F107VFT6	768	LQFP100	Green	Industrial -40°C to +85°C
GD32F107VET6	512	LQFP100	Green	Industrial -40°C to +85°C
GD32F107VDT6	384	LQFP100	Green	Industrial -40°C to +85°C
GD32F107VCT6	256	LQFP100	Green	Industrial -40°C to +85°C
GD32F107VBT6	128	LQFP100	Green	Industrial -40°C to +85°C
GD32F107RGT6	1024	LQFP64	Green	Industrial -40°C to +85°C
GD32F107RFT6	768	LQFP64	Green	Industrial -40°C to +85°C
GD32F107RET6	512	LQFP64	Green	Industrial -40°C to +85°C
GD32F107RDT6	384	LQFP64	Green	Industrial -40°C to +85°C
GD32F107RCT6	256	LQFP64	Green	Industrial -40°C to +85°C
GD32F107RBT6	128	LQFP64	Green	Industrial -40°C to +85°C

7. Revision history

Table 7-1. Revision history

Revision No.	Description	Date
1.0	Initial Release	Oct.25, 2013
1.1	1. Characteristics values modified, refers to <u>Electrical characteristics</u> .	Nov.10, 2013
1.2	1. Repair history accumulation error.	Jan.24, 2018
1.3	1. Delete the PD0, PD1 remap to OSC pins information in packages no less than 100 pins, refers to <u>Pin definitions</u> .	Feb.15, 2020
1.4	1. Integrate the boot loader address in chapter <u>Memory map</u> together. 2. Add description of V _{REF+} and V _{REF-} connection in chapter <u>Analog to digital converter (ADC)</u> . 3. Remove all TIMER7 information from GD32F107xx datasheet. 4. Arm® Cortex® written format modification.	Sep.18, 2020
1.5	1. Table 4-3 update, refers to <u>Table 4-3. Power consumption characteristics</u> .	Apr.12, 2021
1.6	1. Delete PD0 / PD1 from OSCIN / OSCOUT remap information in chapter 2.6.3, refers to <u>Pin definitions</u> . 2. Modify pinouts, refers to <u>Pinouts and pin assignment</u> . 3. Characteristics values modified, refers to <u>Electrical characteristics</u> . 4. Package information and Ordering information update, refer to <u>Package information</u> and <u>Ordering information</u> . 5. Modify the notes under <u>Table 4-1. Absolute maximum ratings⁽¹⁾⁽⁴⁾</u> . 6. Modify Vesd (HBM) and Vesd (CDM) standards, refers to <u>Electrical characteristics</u> . 7. Modify WDGT characteristics, refers to <u>WDGT characteristics</u> . 8. Modify SPI/I2S diagrams, refer to <u>SPI characteristics</u> and <u>I2S characteristics</u> . 9. Modify I2C characteristics, refer to <u>I2C characteristics</u> . 10. Modify LQFP64 package information, refer to <u>LQFP64</u>	Jun.30, 2022



	<p><u>package outline dimensions.</u></p> <p>11. Delete related static parameter in <u>DAC</u></p> <p><u>characteristics.</u></p> <p>12. Update NRST external pin circuit, refer to <u>Figure 4-4.</u></p> <p><u>Recommended external NRST pin circuit⁽¹⁾.</u></p> <p>13. EXMC related pin update, refer to <u>Pin definitions.</u></p>	
--	--	--

Important Notice

This document is the property of GigaDevice Semiconductor Inc. and its subsidiaries (the "Company"). This document, including any product of the Company described in this document (the "Product"), is owned by the Company under the intellectual property laws and treaties of the People's Republic of China and other jurisdictions worldwide. The Company reserves all rights under such laws and treaties and does not grant any license under its patents, copyrights, trademarks, or other intellectual property rights. The names and brands of third party referred thereto (if any) are the property of their respective owner and referred to for identification purposes only.

The Company makes no warranty of any kind, express or implied, with regard to this document or any Product, including, but not limited to, the implied warranties of merchantability and fitness for a particular purpose. The Company does not assume any liability arising out of the application or use of any Product described in this document. Any information provided in this document is provided only for reference purposes. It is the responsibility of the user of this document to properly design, program, and test the functionality and safety of any application made of this information and any resulting product. Except for customized products which has been expressly identified in the applicable agreement, the Products are designed, developed, and/or manufactured for ordinary business, industrial, personal, and/or household applications only. The Products are not designed, intended, or authorized for use as components in systems designed or intended for the operation of weapons, weapons systems, nuclear installations, atomic energy control instruments, combustion control instruments, airplane or spaceship instruments, transportation instruments, traffic signal instruments, life-support devices or systems, other medical devices or systems (including resuscitation equipment and surgical implants), pollution control or hazardous substances management, or other uses where the failure of the device or Product could cause personal injury, death, property or environmental damage ("Unintended Uses"). Customers shall take any and all actions to ensure using and selling the Products in accordance with the applicable laws and regulations. The Company is not liable, in whole or in part, and customers shall and hereby do release the Company as well as its suppliers and/or distributors from any claim, damage, or other liability arising from or related to all Unintended Uses of the Products. Customers shall indemnify and hold the Company as well as its suppliers and/or distributors harmless from and against all claims, costs, damages, and other liabilities, including claims for personal injury or death, arising from or related to any Unintended Uses of the Products.

Information in this document is provided solely in connection with the Products. The Company reserves the right to make changes, corrections, modifications or improvements to this document and Products and services described herein at any time, without notice.