

PRODUCT NUMBER STRUCTURE

10164227 - AAABCDEF

No. of Pins:
 020=20Pin; 024=24Pin;
 030=30Pin; 034=34Pin;
 040=40Pin; 050=50Pin;
 060=60Pin; 070=70Pin;
 080=80Pin; 090=90Pin;
 100=100Pin; 120=120Pin.

Height:
 1=1.45mm

Contact plating:
 A=Gold flash

Hold down:
 1=Without hold down

Packing:
 R=Tape & Reel

LF:
 LF=Lead free

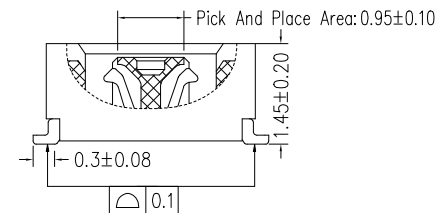
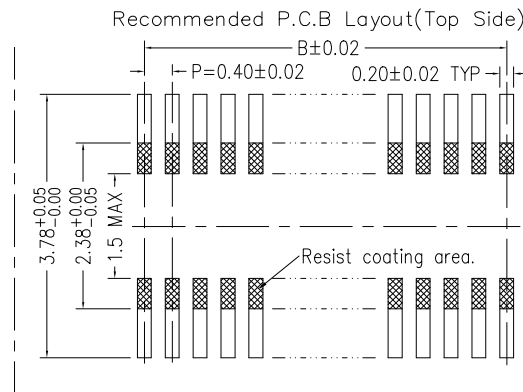
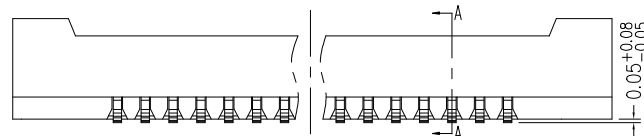
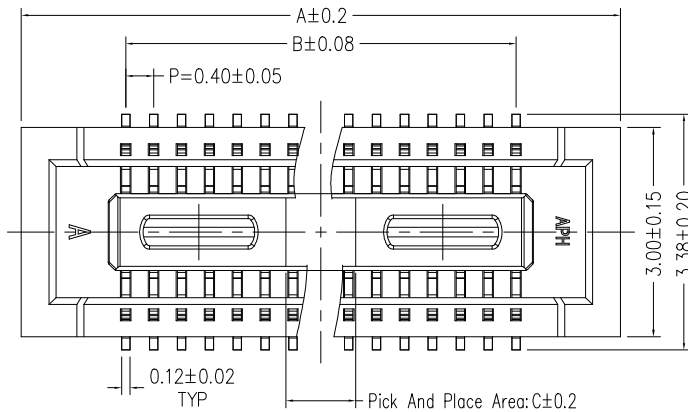

Note

1. CURRENT RATING: 0.3A ;
2. VOLTAGE RATING: 30V AC ;
3. CONTACT RESISTANCE: 90mΩ Max;
4. WITHSTAND VOLTAGE : 100V AC;
5. INSULATION RESISTANCE: 50MΩ Min;
6. INSULATOR MATERIAL: LCP, G.F, UL94V-0, BK;
7. CONTACT MATERIAL: Copper Alloy;
8. CONTACT PLATING:
 GOLD FLASH ON CONTACT AREA(SEE ORDERING INFORMATION),
 50μ" NICKEL UNDERPLATING OVERALL;
9. CO-PLANARITY FOR CONTACT TAILS MUST BE 0.1mm MAX.
10. THIS PRODUCT MEETS EUROPEAN UNION DIRECTIVES AND OTHER COUNTRY REGULATIONS AS DESCRIBED IN GS-47-0004.
10. THE HOUSING WILL WITHSTAND EXPOSURE TO 260°C PEAK TEMPERATURE FOR 10SECONDS IN A REFLOW SOLDERING OVEN.
12. RECOMMENDED STENCIL THICKNESS IS 120um.
13. RECOMMENDED STENCIL OPENING RATIO IS 80%.
14. PRODUCT SPEC : GS-12-1404.
15. THE DOCUMENT MAY BE CHANGED WITHOUT PRIOR NOTICE.

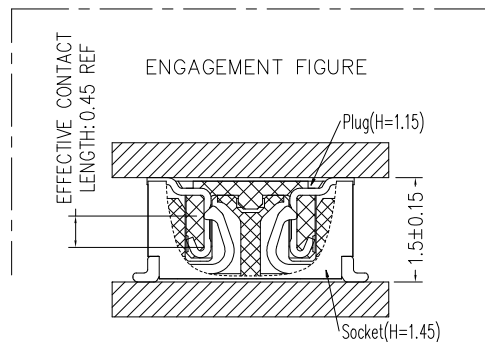

PART NO.	NO. of contacts	A	B	C
10164227-0101A1RLF	10	4.60	1.60	1.0
10164227-0201A1RLF	20	6.60	3.60	1.0
10164227-0241A1RLF	24	7.40	4.40	1.0
10164227-0301A1RLF	30	8.60	5.60	1.5
10164227-0341A1RLF	34	9.40	6.40	2.3
10164227-0401A1RLF	40	10.60	7.60	3.2
10164227-0501A1RLF	50	12.60	9.60	3.2
10164227-0601A1RLF	60	14.60	11.60	3.2
10164227-0701A1RLF	70	16.60	13.60	3.2
10164227-0801A1RLF	80	18.60	15.60	3.2
10164227-0901A1RLF	90	20.60	17.60	3.2
10164227-1001A1RLF	100	22.60	19.60	3.2
10164227-1201A1RLF	120	26.60	23.60	3.2

mat'l. code		surface ISO 1302 ✓		tolerance ISO 406 ISO 1101		projection		product family	
ltr		ecn no		dr		date		BERGSTAK	
A		-		YY		2022/04/01		title	
B		ELX-N-46224-1		YY		2022/11/14		RECEPTACLE	
				angles		linear		BERGSTAK 0.4MM BTB	
				0°±2'		.00±.25 .00±.20 .000±.10		scale 1:1	
				dr		Y-Y Bao		2022/11/14	
				enr		Y-Y Bao		2022/11/14	
				chr		L-Q Lei		2022/11/14	
				appd		Tim Yao		2022/11/14	
sheet index		revision		B		1~6		dwg no	
								sheet 1 of 6	
								size	
								A3	
								type	
								Product Customer Drawing	

PRODUCT NUMBER STRUCTURE

10164227 - AAABCDELF

Na.of Pins:
 020=20Pin; 030=30Pin;
 040=40Pin; 050=50Pin;
 060=60Pin; 070=70Pin
 Height:
 2=2.4mm
 Contact plating:
 A=Gold flash
 Hold down:
 1=Without hold down
 Packing:
 R=Tape & Reel
 LF:
 LF=Lead free

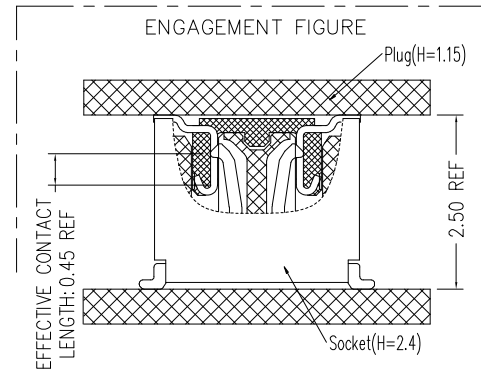
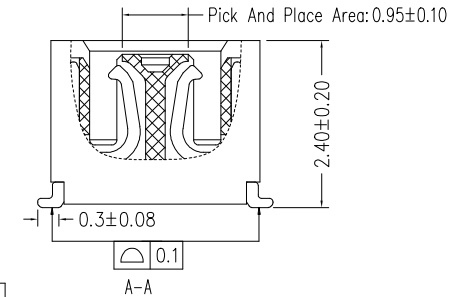
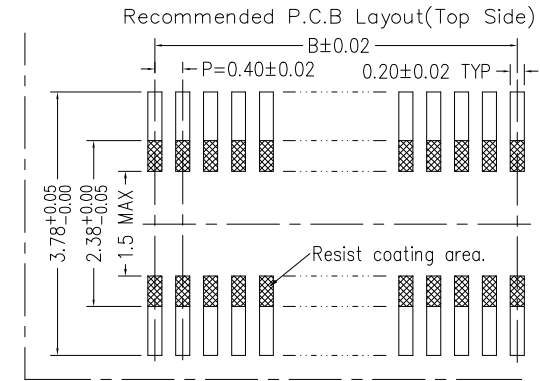
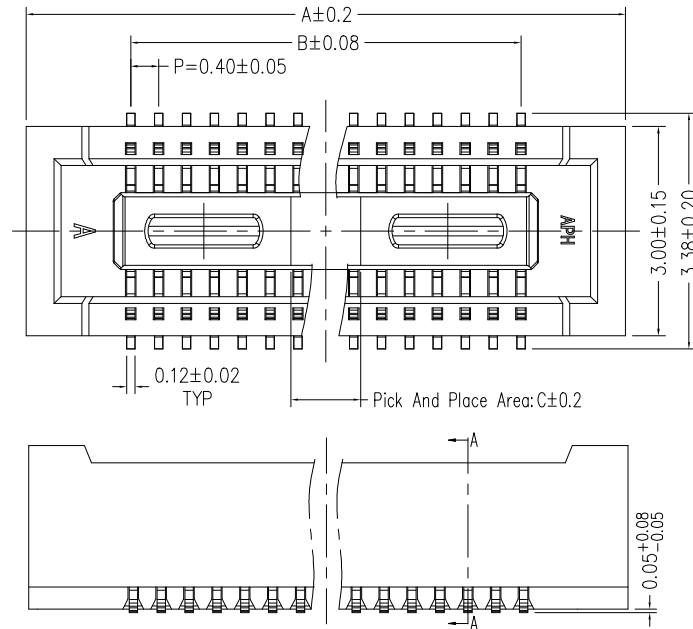

PART NO.	NO.of contacts	A	B	C
10164227-0202A1RLF	20	6.60	3.60	1.0
10164227-0302A1RLF	30	8.60	5.60	1.5
10164227-0402A1RLF	40	10.60	7.60	3.2
10164227-0502A1RLF	50	12.60	9.60	3.2
10164227-0602A1RLF	60	14.60	11.60	3.2
10164227-0702A1RLF	70	16.60	13.60	3.2

- Note
- CURRENT RATING: 0.3A ;
 - VOLTAGE RATING: 30V AC ;
 - CONTACT RESISTANCE: 90mΩ Max;
 - WITHSTAND VOLTAGE : 100V AC;
 - INSULATION RESISTANCE: 50MΩ Min;
 - INSULATOR MATERIAL: LCP,G.F,UL94V-0,BK;
 - CONTACT MATERIAL: Copper Alloy;
 - CONTACT PLATING:
 GOLD FLASH ON CONTACT AREA(SEE ORDERING INFORMATION),
 50μ" NICKEL UNDERPLATING OVERALL;
 - CO-PLANARITY FOR CONTACT TAILS MUST BE 0.1mm MAX.
 - THIS PRODUCT MEETS EUROPEAN UNION DIRECTIVES AND OTHER COUNTRY REGULATIONS AS DESCRIBED IN GS-47-0004.
 - THE HOUSING WILL WITHSTAND EXPOSURE TO 260°C PEAK TEMPERATURE FOR 10SECONDS IN A REFLOW SOLDERING OVEN.
 - RECOMMENDED STENCIL THICKNESS IS 120um.
 - RECOMMENDED STENCIL OPENING RATIO IS 80%.
 - PRODUCT SPEC : GS-12-1404.
 - THE DOCUMENT MAY BE CHANGED WITHOUT PRIOR NOTICE.

mat'l. code		surface ISO 1302 ✓		tolerance ISO 406 ISO 1101		projection 1101		product family BERGSTAK	
ltr	ecn no	dr	date	tolerances unless otherwise specified		mm		title	
B				angles linear	.0±.25	← mm →		RECEPTACLE BERGSTAK 0.4MM BTB	
				0°±2'	.00±.20	scale 1:1		dwg no sheet 2 of 6 size	
				dr	Y-Y Bao	2022/11/14	Amphenol FCI		10164227 A3
				enr	Y-Y Bao	2022/11/14			
				chr	L-Q Lei	2022/11/14			
				appd	Tim Yao	2022/11/14			
sheet index	revision sheet	B	1~6	type Product Customer Drawing					

PRODUCT NUMBER STRUCTURE

10164227 - AAABCDEF

No. of Pins:
 030=30Pin; 040=40Pin;
 044=44Pin; 050=50Pin;
 060=60Pin; 070=70Pin;
 080=80Pin; 090=90Pin;
 100=100Pin;

Height:
 3=2.9mm

Contact plating:
 A=Gold flash

Hold down:
 1=Without hold down

Packing:
 R=Tape & Reel

LF:
 LF=Lead free

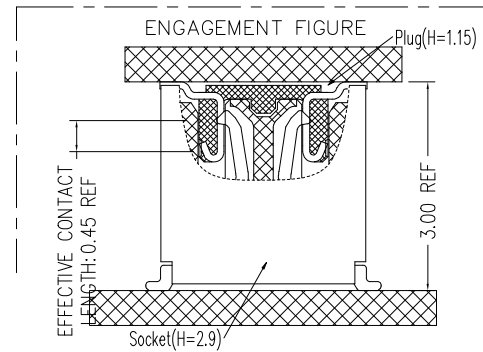
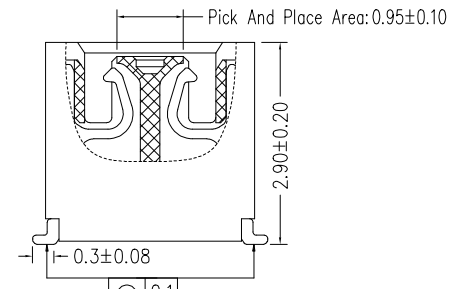
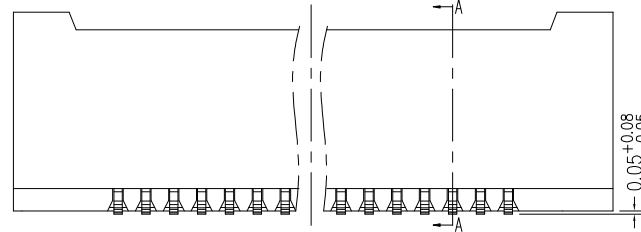
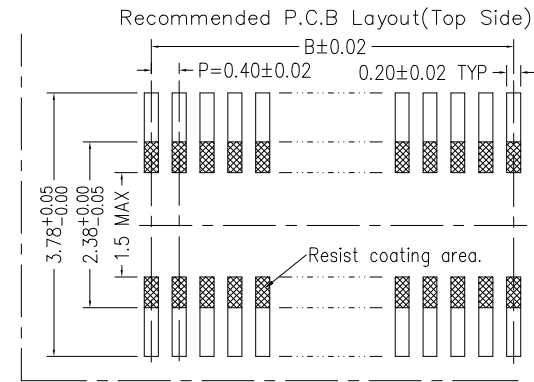
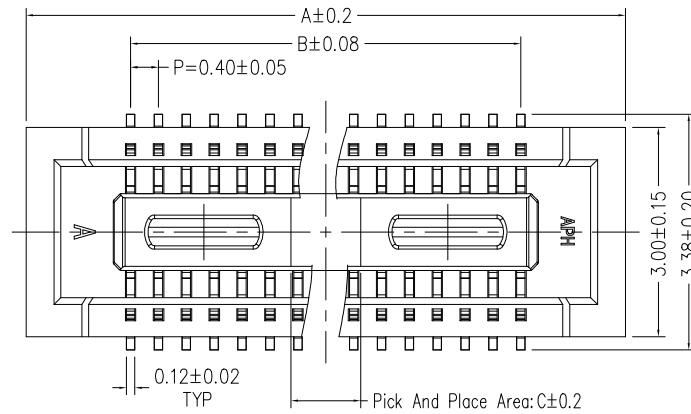

- Note
- CURRENT RATING: 0.3A ;
 - VOLTAGE RATING: 30V AC ;
 - CONTACT RESISTANCE: 90mΩ Max;
 - WITHSTAND VOLTAGE : 100V AC;
 - INSULATION RESISTANCE: 50MΩ Min;
 - INSULATOR MATERIAL: LCP,G.F,UL94V-0,BK;
 - CONTACT MATERIAL: Copper Alloy;
 - CONTACT PLATING:
 GOLD FLASH ON CONTACT AREA(SEE ORDERING INFORMATION),
 50μ" NICKEL UNDERPLATING OVERALL;
 - CO-PLANARITY FOR CONTACT TAILS MUST BE 0.1mm MAX.
 - THIS PRODUCT MEETS EUROPEAN UNION DIRECTIVES AND OTHER COUNTRY REGULATIONS AS DESCRIBED IN GS-47-0004.
 - THE HOUSING WILL WITHSTAND EXPOSURE TO 260°C PEAK TEMPERATURE FOR 10SECONDS IN A REFLOW SOLDERING OVEN.
 - RECOMMENDED STENCIL THICKNESS IS 120um.
 - RECOMMENDED STENCIL OPENING RATIO IS 80%.
 - PRODUCT SPEC : GS-12-1404.
 - THE DOCUMENT MAY BE CHANGED WITHOUT PRIOR NOTICE.

PART NO.	NO. of contacts	A	B	C
10164227-0303A1RLF	30	8.60	5.60	1.5
10164227-0403A1RLF	40	10.60	7.60	3.2
10164227-0443A1RLF	44	11.40	8.40	3.2
10164227-0503A1RLF	50	12.60	9.60	3.2
10164227-0603A1RLF	60	14.60	11.60	3.2
10164227-0703A1RLF	70	16.60	13.60	3.2
10164227-0803A1RLF	80	18.60	15.60	3.2
10164227-0903A1RLF	90	20.60	17.60	3.2
10164227-1003A1RLF	100	22.60	19.60	3.2

mat'l. code		surface ISO 1302 ✓		tolerance ISO 406 ISO 1101		projection 1101		product family BERGSTAK	
ltr	ecn no	dr	date	tolerances unless otherwise specified		mm		title	
B				angles linear	.0±.25	← mm →		RECEPTACLE BERGSTAK 0.4MM BTB	
				0'±2'	.00±.20	scale 1:1		dwg no sheet 3 of 6 size	
				dr	Y-Y Bao	2022/11/14	Amphenol FCI		10164227 A3
				engr	Y-Y Bao	2022/11/14			
				chr	L-Q Lei	2022/11/14			
				appd	Tim Yao	2022/11/14			
sheet index	revision sheet	B 1~6							
type		Product Customer Drawing							

PRODUCT NUMBER STRUCTURE

10164227 - AAABCDELFF

No. of Pins:
050=50Pin; 060=60Pin
080=80Pin; 090=90Pin
Height:
4=3.9mm
Contact plating:
A=Gold flash
Hold down:
1=Without hold down
Packing:
R=Tape & Reel
LF:
LF=Lead free

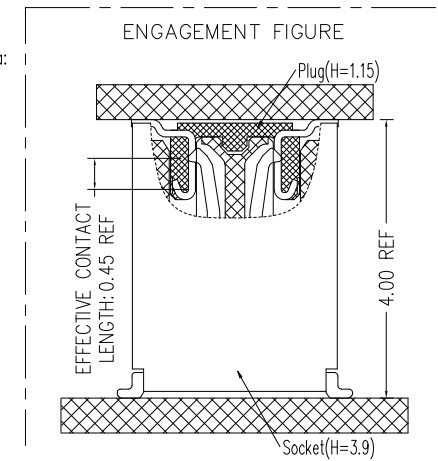
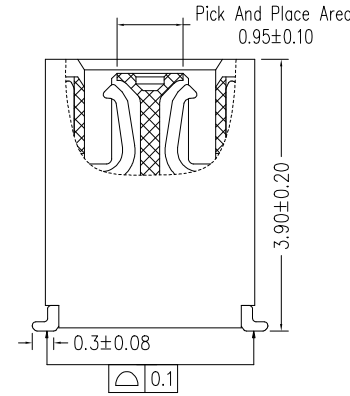
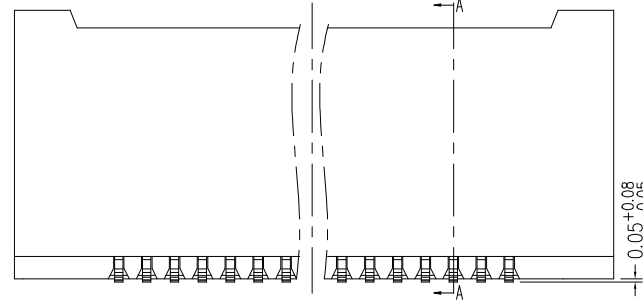
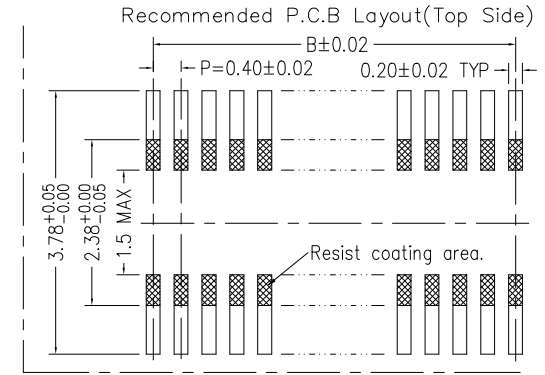
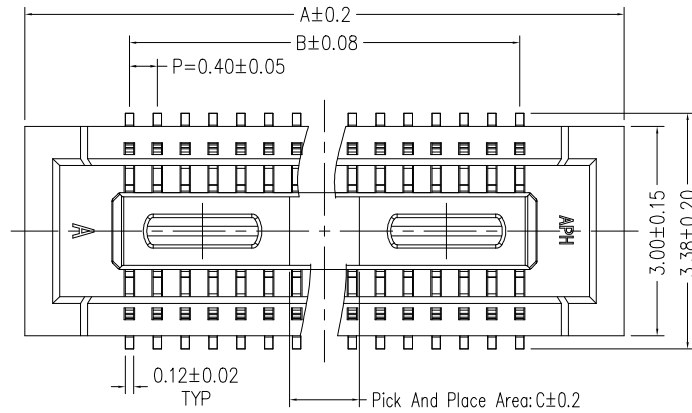

Note

- CURRENT RATING: 0.3A ;
- VOLTAGET RATING: 30V AC ;
- CONTACT RESISTANCE: 90mΩ Max;
- WITHSTAND VOLTAGE : 100V AC;
- INSULATION RESISTANCE: 50MΩ Min;
- INSULATOR MATERIAL: LCP,G.F,UL94V-0,BK;
- CONTACT MATERIAL: Copper Alloy;
- CONTACT PLATING:
GOLD FLASH ON CONTACT AREA(SEE ORDERING INFOMATION),
50 μ" NICKEL UNDERPLATING OVERALL;
- CO-PLANARITY FOR CONTACT TAILS MUST BE 0.1mm MAX.
- THIS PRODUCT MEETS EUROPEAN UNION DIRECTIVES AND OTHER COUNTRY REGULATIONS AS DESCRIBED IN GS-47-0004.
- THE HOUSING WILL WITHSTAND EXPOSURE TO 260°C PEAK TEMPERATURE FOR 10SECONDS IN A REFLOW SOLDERING OVEN.
- RECOMMENDED STENCIL THICKNESS IS 120um.
- RECOMMENDED STENCIL OPENING RATIO IS 80%.
- PRODUCT SPEC : GS-12-1404.
- THE DOCUMENT MAY BE CHANGED WITHOUT PRIOR NOTICE.

PART NO.	NO. of contacts	A	B	C
10164227-0404A1RLF	40	10.60	7.60	3.2
10164227-0504A1RLF	50	12.60	9.60	3.2
10164227-0604A1RLF	60	14.60	11.60	3.2
10164227-0704A1RLF	70	16.60	13.60	3.2
10164227-0804A1RLF	80	18.60	15.60	3.2
10164227-0904A1RLF	90	20.60	17.60	3.2
10164227-1004A1RLF	100	22.60	19.60	3.2

mat'l. code		surface ISO 1302 ✓		tolerance ISO 406 ISO 1101		projection 1101		product family BERGSTAK		
ltr	ecn no	dr	date	tolerances unless otherwise specified		mm		title		
B				angles	linear	mm		RECEPTACLE BERGSTAK 0.4MM BTB		
				0°±2'		scale 1:1		dwg no sheet 4 of 6 size		
				dr	Y-Y Bao	2022/11/14	Amphenol FCI		10164227 A3	
				engr	Y-Y Bao	2022/11/14				
				chr	L-Q Lei	2022/11/14				
				appd	Tim Yao	2022/11/14				
sheet index	revision sheet	B	1~6							type Product Customer Drawing

PRODUCT NUMBER STRUCTURE

10164227 - AAABCDELFF

No. of Pins:
 020=20Pin; 030=30Pin;
 040=40Pin; 050=50Pin;
 060=60Pin; 080=80Pin

Height:
 5=3.45mm

Contact plating:
 A=Gold flash

Hold down:
 1=Without hold down

Packing:
 R=Tape & Reel

LF:
 LF=Lead free

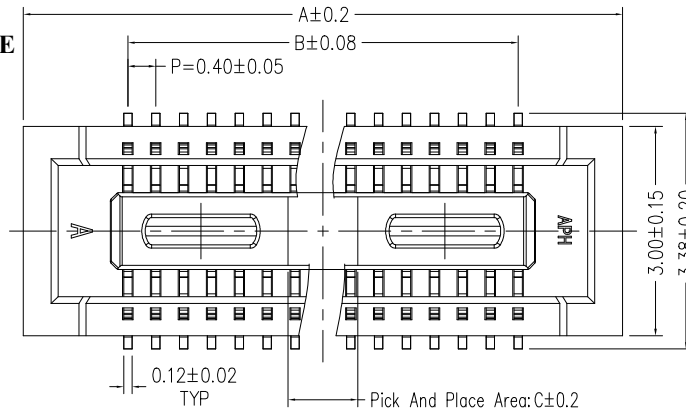

Recommended P.C.B Layout(Top Side)

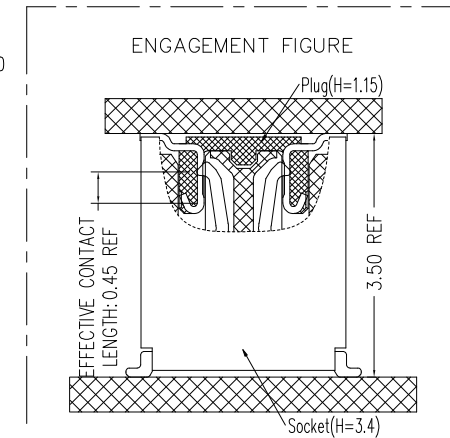
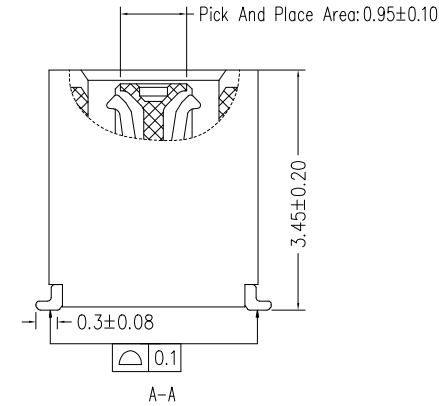
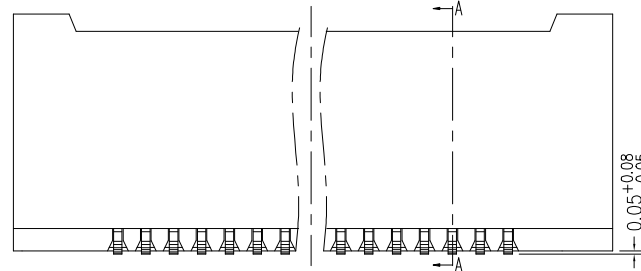
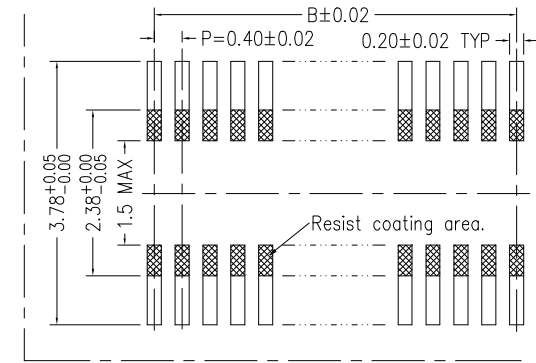

Note

1. CURRENT RATING: 0.3A ;
2. VOLTAGE RATING: 30V AC ;
3. CONTACT RESISTANCE: 90mΩ Max;
4. WITHSTAND VOLTAGE : 100V AC;
5. INSULATION RESISTANCE: 50MΩ Min;
6. INSULATOR MATERIAL: LCP,G.F,UL94V-0,BK;
7. CONTACT MATERIAL: Copper Alloy;
8. CONTACT PLATING:
 GOLD FLASH ON CONTACT AREA(SEE ORDERING INFORMATION),
 50 μ" NICKEL UNDERPLATING OVERALL;
9. CO-PLANARITY FOR CONTACT TAILS MUST BE 0.1mm MAX.
10. THIS PRODUCT MEETS EUROPEAN UNION DIRECTIVES AND OTHER COUNTRY REGULATIONS AS DESCRIBED IN GS-47-0004.
10. THE HOUSING WILL WITHSTAND EXPOSURE TO 260°C PEAK TEMPERATURE FOR 10SECONDS IN A REFLOW SOLDERING OVEN.
12. RECOMMENDED STENCIL THICKNESS IS 120um.
13. RECOMMENDED STENCIL OPENING RATIO IS 80%.
14. PRODUCT SPEC : GS-12-1404.
15. THE DOCUMENT MAY BE CHANGED WITHOUT PRIOR NOTICE.

PART NO.	NO. of contacts	A	B	C
10164227-0205A1RLF	20	6.60	3.60	1.0
10164227-0305A1RLF	30	8.60	5.60	1.5
10164227-0405A1RLF	40	10.60	7.60	3.2
10164227-0505A1RLF	50	12.60	9.60	3.2
10164227-0605A1RLF	60	14.60	11.60	3.2
10164227-0805A1RLF	80	18.60	15.60	3.2

mat'l. code		surface ISO 1302 ✓		tolerance ISO 406 ISO 1101		projection		product family	
ltr		ecn no		dr		date		BERGSTAK	
B								title	
								RECEPTACLE	
								BERGSTAK 0.4MM BTB	
								dwg no	
								sheet 5 of 6	
								size	
								A3	
								type	
								Product Customer Drawing	
sheet index		revision sheet		B 1~6					

Amphenol FCI

© 2016 AFCI

PRODUCT NUMBER STRUCTURE

10164227 - AAABCDELFF

No. of Pins:
 020=20Pin; 024=24Pin;
 030=30Pin; 040=40Pin;
 050=50Pin; 060=60Pin;
 070=70Pin; 080=80Pin;

Height:
 6=1.95mm

Contact plating:
 A=Gold flash
 B=8u" Min. AU
 C=15u" Min. AU

Hold down:
 1=Without hold down

Packing:
 R=Tape & Reel

LF:
 LF=Lead free

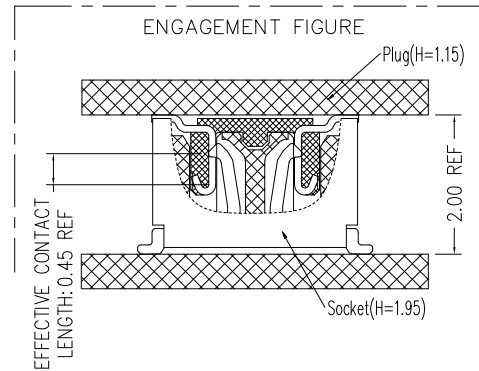
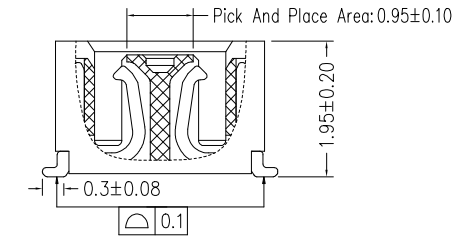
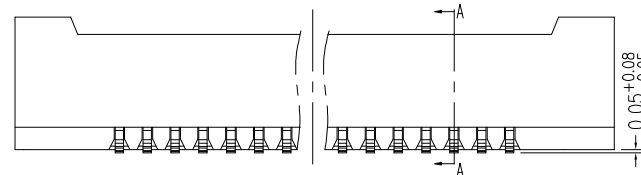
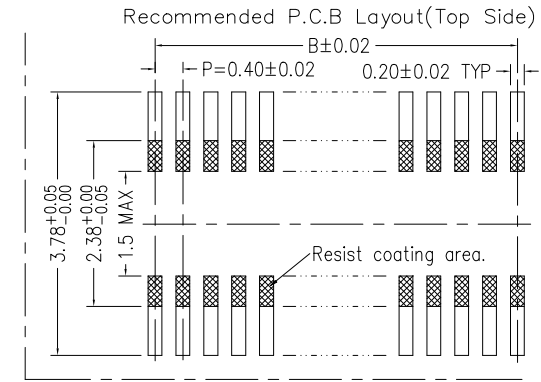
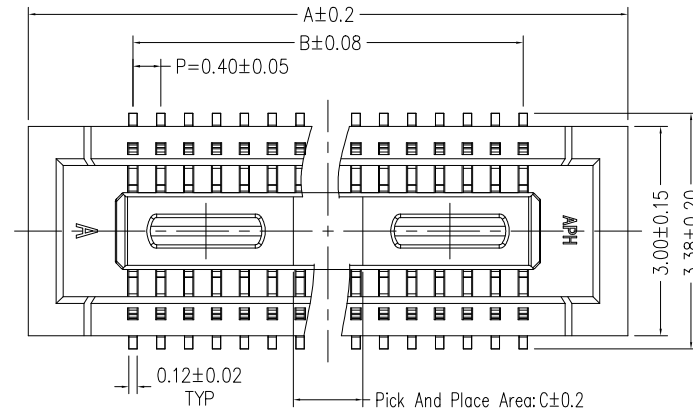

- Note
- CURRENT RATING: 0.3A ;
 - VOLTAGE RATING: 30V AC ;
 - CONTACT RESISTANCE: 90mΩ Max;
 - WITHSTAND VOLTAGE : 100V AC;
 - INSULATION RESISTANCE: 50MΩ Min;
 - INSULATOR MATERIAL: LCP,G.F,UL94V-0,BK;
 - CONTACT MATERIAL: Copper Alloy;
 - CONTACT PLATING:
 GOLD FLASH ON CONTACT AREA(SEE ORDERING INFORMATION),
 50μ" NICKEL UNDERPLATING OVERALL;
 - CO-PLANARITY FOR CONTACT TAILS MUST BE 0.1mm MAX.
 - THIS PRODUCT MEETS EUROPEAN UNION DIRECTIVES AND OTHER COUNTRY REGULATIONS AS DESCRIBED IN GS-47-0004.
 - THE HOUSING WILL WITHSTAND EXPOSURE TO 260°C PEAK TEMPERATURE FOR 10SECONDS IN A REFLOW SOLDERING OVEN.
 - RECOMMENDED STENCIL THICKNESS IS 120um.
 - RECOMMENDED STENCIL OPENING RATIO IS 80%.
 - PRODUCT SPEC : GS-12-1404.
 - THE DOCUMENT MAY BE CHANGED WITHOUT PRIOR NOTICE.

PART NO.	NO. of contacts	A	B	C
10164227-0206A1RLF	20	6.60	3.60	1.0
10164227-0246A1RLF	24	7.40	4.40	1.0
10164227-0306A1RLF	30	8.60	5.60	1.5
10164227-0406A1RLF	40	10.60	7.60	3.2
10164227-0506A1RLF	50	12.60	9.60	3.2
10164227-0606A1RLF	60	14.60	11.60	3.2
10164227-0706A1RLF	70	16.60	13.60	3.2
10164227-0806A1RLF	80	18.60	15.60	3.2

mat'l. code		surface ISO 1302 ✓		tolerance ISO 406 ISO 1101		projection 1101		product family BERGSTAK	
ltr	ecn no	dr	date	tolerances unless otherwise specified		mm		title	
B				angles linear	.0±.25	← mm →		RECEPTACLE BERGSTAK 0.4MM BTB	
				0°±2'	.00±.20	scale 1:1		dwg no sheet 6 of 6 size	
				dr	Y-Y Bao	2022/11/14	Amphenol FCI		10164227 A3
				enr	Y-Y Bao	2022/11/14			
				chr	L-Q Lei	2022/11/14			
				appd	Tim Yao	2022/11/14			
sheet index	revision sheet	B	1~6	type Product Customer Drawing					