

PRODUCT NO.	ROWS	SIGNAL			
		E1	1	2	3
51939-805-- NOTE 3	D C B A				

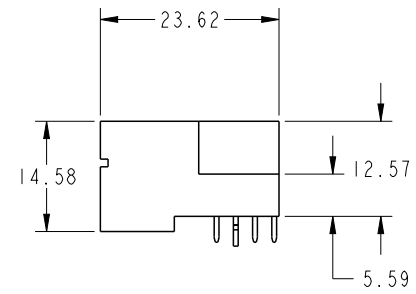

CODE	DIM "M" MATING LENGTH	CONTACT TYPE
U	[6.86]	SIGNAL
T	[6.86]	SIGNAL
S	[6.86]	SIGNAL
R	[6.86]	SIGNAL
G	[5.59]	SIGNAL
HA	[N/A]	HOLD-DOWN

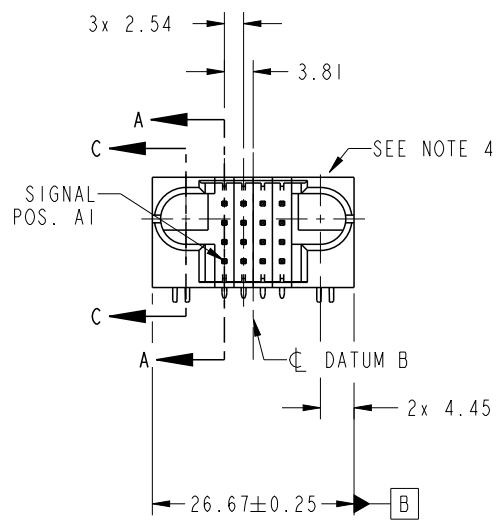

Copyright FCI.

spec ref	*	dr	Ruan MT	2013/08/14	projection	MM	size	A4	scale	1:1	
tolerance std	ASME Y14.5	eng	Ruan MT	2013/09/10			ecn no	-			
TOLERANCES UNLESS OTHERWISE SPECIFIED		chr	-	-				rel level	Released		
surface		appr	Pei-Ming Zheng	2013/09/10	product family	PwrBlade					
ASME Y14.5		linear	0.X	±0.5		title 16S RIGHT ANGLE SOLDER HEADER	dwg no 51939-805	rev			
				0.XX				±0.25	A		
			0.XXX	±0.1							
	angular	0°	±2°	www.fci.com	cat. no.	-	Product - Customer Drw		sheet 1 of 4		

PrintE File - REV C - 2009-06-09

PRODUCT NUMBER

51939-805--  
NOTE: 3

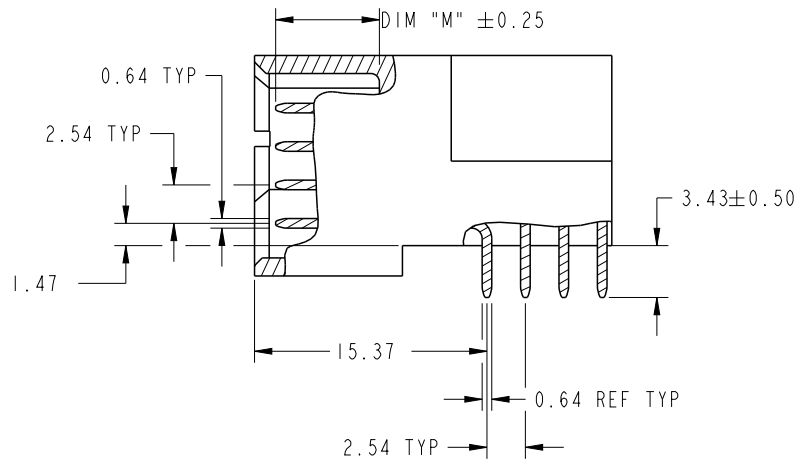

BROKEN-OUT SECTION A-A  
SCALE 2:1

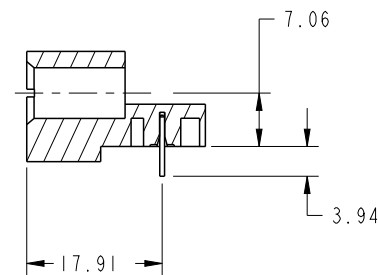

SECTION C-C

dr	Ruan MT	2013/08/14	projection 	MM 	size	A4	scale	1:1
eng	Ruan MT	2013/09/10			ecn no	-		
chr	-	-			rel level	Released		
appr	Pei-Ming Zheng	2013/09/10	product family	PwrBlade	rev	A		
	title	16S RIGHT ANGLE SOLDER HEADER		dwg no	51939-805			
www.fci.com	cat. no.	-	Product - Customer Drw	sheet 2 of 4				

PRODUCT NUMBER

51939-805\_\_  
NOTE: 3

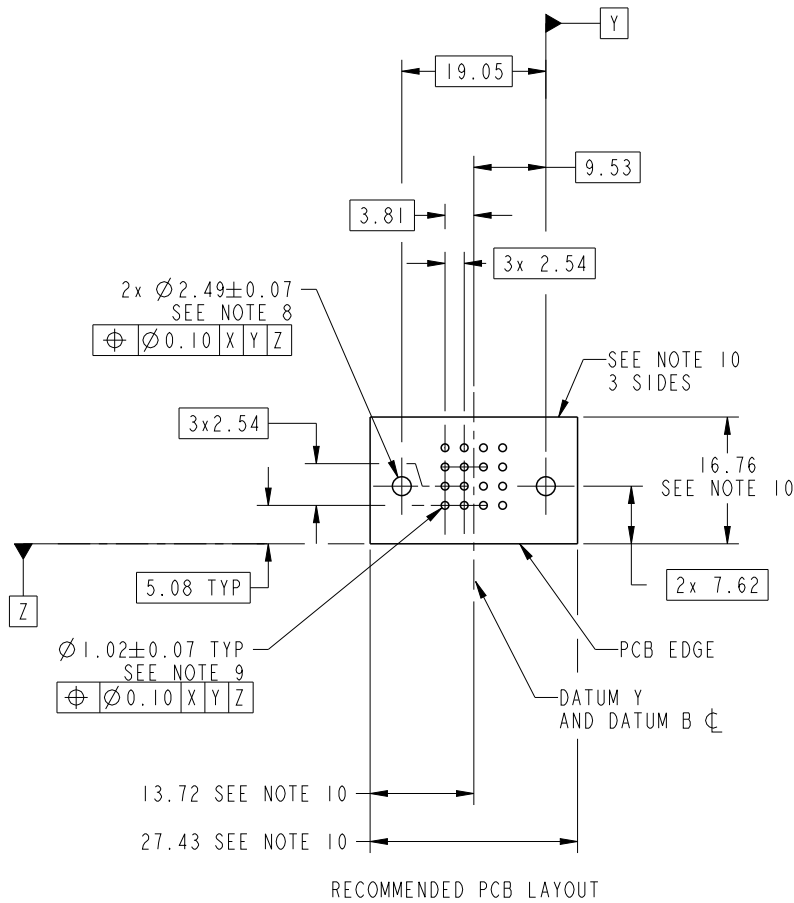

RECOMMENDED PCB LAYOUT

dr	Ruan MT	2013/08/14	projection 	MM 	size	A4	scale	1:1
eng	Ruan MT	2013/09/10			ecn no	-		
chr	-	-			rel level	Released		
appr	Pei-Ming Zheng	2013/09/10	product family	PwrBlade				
	title	16S RIGHT ANGLE SOLDER HEADER		dwg no	51939-805		rev	A
www.fci.com	cat. no.	-	Product - Customer Drw		sheet 3 of 4			

PRODUCT NUMBER

51939-805\_\_  
NOTE: 3

NOTES:

1. DIMENSIONS AND TOLERANCES ARE IN ACCORDANCE WITH ASME Y14.5M, 1994 UNLESS OTHERWISE SPECIFIED.

CONNECTOR NOTES:

- 2. HOUSING MATERIAL: UL 94 V-0 GLASS FILLED HIGH-TEMP THERMOPLASTIC  
POWER CONTACT MATERIAL: COPPER ALLOY  
SIGNAL PIN MATERIAL: COPPER ALLOY
- 3. SEE ITEM 1 & 2 IN PRINT 10064183 FOR PLATING SPEC OF 51939-805 AND 51939-805LF RESPECTIVELY.
- 4. MANUFACTURER'S NAME, DATE CODE AND OPTIONAL P/N TO APPEAR ON THIS SURFACE. THE MARK CAN BE OMITTED IF THERE IS NOT ENOUGH SPACE ON THIS SURFACE.
- 5. PRODUCT SPECIFICATION GS-12-149.  
APPLICATION SPECIFICATION BUS-20-067.
- 6. PACKAGED IN TRAYS.

PCB NOTES:

- 7. ALL HOLE DIAMETERS ARE FINISHED HOLE SIZE.
- 8. MOUNTING HOLES, WHERE APPLICABLE, ARE UNPLATED.
- 9.  $\varnothing 1.151 \pm 0.025$  DRILLED HOLES PLATED WITH  
0.008 MIN SnPb OR Sn OVER 0.03  
TO 0.08 Cu PLATING TO ACHIEVE  
 $\varnothing 1.02 \pm 0.07$  HOLE.
- 10. CONNECTOR KEEP-OUT ZONE.

dr	Ruan MT	2013/08/14	projection 	MM 	size	A4	scale	1:1		
eng	Ruan MT	2013/09/10			ecn no	-				
chr	-	-			product family	PwrBlade	rel level	Released		
appr	Pei-Ming Zheng	2013/09/10			title	16S RIGHT ANGLE SOLDER HEADER	dwg no	51939-805	rev	A
www.fci.com		cat. no.	-	Product - Customer Drw			sheet 4 of 4			



Copyright FCI.