

NOTES:

1. ROHS COMPLIANT
2. HEADER: PHENOLIC WITH FLAMMABILITY RATING UL 94V-0 OR BETTER.
3. STORAGE TEMPERATURE: -20°C TO +125°C
4. COMPLIANCE TO J-STD:
  - A. J-STD-002: SOLDERABILITY AT 245°C REFLOW PROFILE
  - B. J-STD-020: LEVEL 1, NO MOISTURE SENSITIVE
  - C. J-STD-075: R7, 245°C MAXIMUM THROUGH REFLOW SOLDER
5. TO ORDER TAPE & REEL PACKAGING ADD A "T" SUFFIX TO THE PART NUMBER (i.e PE-65812FNL BECOMES PE-65812FNLT).

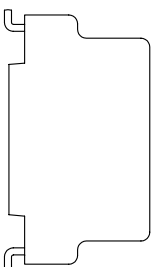
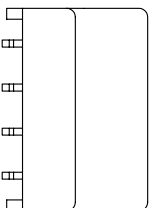
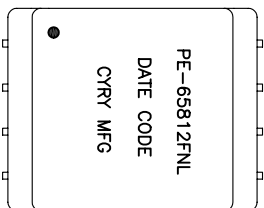

FINAL OUTLINE

© Copyright, 2014. Pulse Electronics Corp. All rights reserved. Pulse confidential & proprietary. (06/30/14)

PRODUCT DESCRIPTION	TLA DRAWING	PS DRAWING	SHEET	PART NO.	DATASHEET REV.
XFMR,SGL,DGTL/AUD,IA,1:1,RL	PE-65812FNL-10	PS-2752.001-B	1 OF 3	PE-65812FNL	A

ELECTRICAL CHARACTERISTICS AT +25°C UNLESS OTHER SPECIFIED

PARAMETER	SPECIFICATIONS					
OPERATING TEMP	0°C - 70 °C					
POLARITY	PER SCHEMATIC					
TURNS RATIO @10 KHZ, 0.2 VRMS	$\frac{(1-4)}{(8-5)} = 1.00 \pm 2\%$					
INDUCTANCE @100 KHZ, 0.02 VRMS	(1-4) = 2.5 mH $\pm 20\%$					
LEAKAGE INDUCTANCE (LL) @100 KHZ, 0.02 VRMS	(1-4) WITH (8-5) SHORTED = 0.35 $\mu$ H MAXIMUM					
CWW @100 KHZ, 0.02 VRMS	(1-4) TO (8-5) = 40 pF MAXIMUM					
INSERTION LOSS	100 KHZ TO 55 MHZ -3 dB MAXIMUM					
RETURN LOSS	100 KHZ -22 dB MINIMUM	10 MHZ -20 dB MINIMUM				
COMMON MODE REJECTION	100 KHZ -75 dB	1 MHZ -70 dB	3 MHZ -60 dB	6 MHZ -50 dB	10 MHZ -40 dB	30 MHZ -25 dB
HIPOT:	2000 VAC FOR 60 SECONDS					

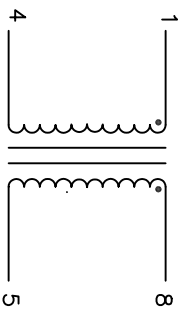

SCHEMATIC

© Copyright, 2014, Pulse Electronics Corp. All rights reserved. Pulse confidential & proprietary. (06/30/14)

PRODUCT DESCRIPTION	TLA DRAWING	PS DRAWING	SHEET	PART NO.	DATASHEET REV.
XFMR,SGL,DGTL/AUD,IA,1:1,RL	PE-65812FNL-10	PS-2752.001-B	2 OF 3	PE-65812FNL	A

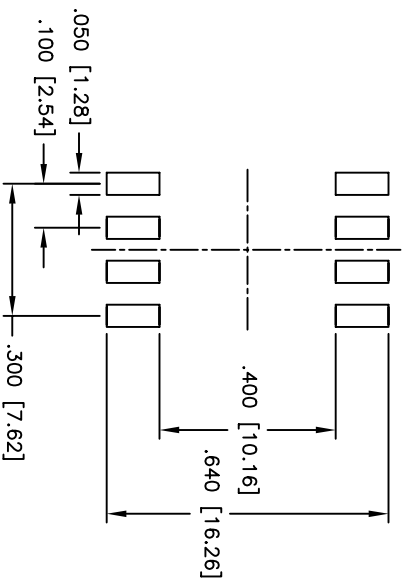
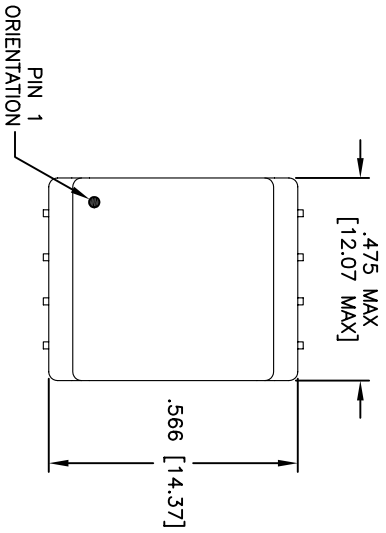

SUGGESTED LAND PATTERN

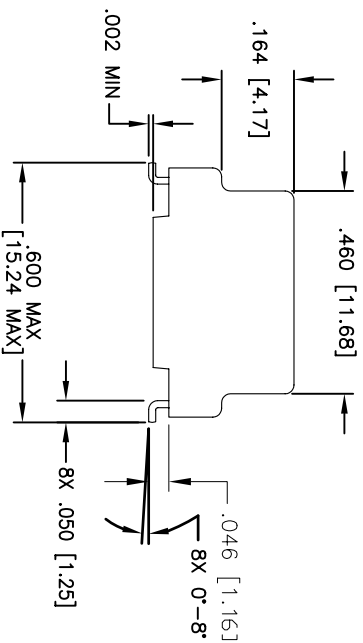
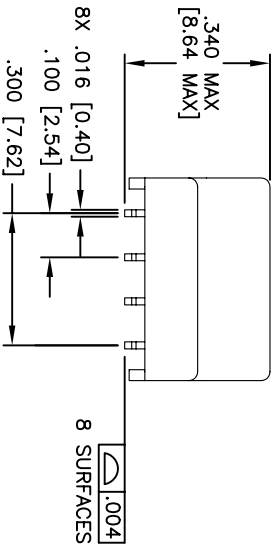

DIMENSIONS ARE IN INCHES [MILLIMETERS] WITH THE FOLLOWING TOLERANCES: [MILLIMETERS] ARE FOR REFERENCE ONLY.  
 .XX = ±.01 [±0.25]  
 .XXX = ±.005 [±0.13]

© Copyright, 2014, Pulse Electronics Corp. All rights reserved. Pulse confidential & proprietary. (06/30/14)

PRODUCT DESCRIPTION	TLA DRAWING	PS DRAWING	SHEET	PART NO.	DATASHEET REV.
XFMR,SGL,DGTL/AUD,LA,1:1,RL	PE-65812FNL-10	PS-2752.001-B	3 OF 3	PE-65812FNL	A

E-MAIL: PRODINFONETWORK@PULSEELECTRONICS.COM(US), ASIA@PU SFELCTRONICS.COM(Asia) PHONE: USA:858 674 8100, GERMANY:49 7032 78060, SINGAPORE:65 6287 8998, SHANGHAI:86 21 62787060, TAIWAN:886 3 4356788