

L9437

LED emitting collimated light for optical encoder

The L9437 is an infrared LED developed for optical encoders. By improving the aspherical lens used with the previous type L8506, we have achieved an even more highly collimated beam of near infrared light. The lead pin of the L9437 has no step piece that is usually formed at the lead base brazed to the package, thus eliminating the restriction in printed circuit board design.

Features

- Collimated light beam
- Uniform light spot
- Narrow directivity: $\pm 5^\circ$
- High-speed response: 40 MHz typ.
- High reliability

Applications

- Optical encoder

Absolute maximum ratings (Ta=25 °C unless otherwise noted)

Parameter	Symbol	Value	Unit
Reverse voltage	VR	5	V
Forward current	IF	80	mA
Forward current reduction rate	-	0.25	mA/°C
Power dissipation	P	150	mW
Operating temperature	Topr	-30 to +105	°C
Storage temperature	Tstg	-40 to +105	°C

Note: Exceeding the absolute maximum ratings even momentarily may cause a drop in product quality. Always be sure to use the product within the absolute maximum ratings.

Electrical and optical characteristics (Ta=25 °C)

Parameter	Symbol	Condition	Min.	Typ.	Max.	Unit
Peak emission wavelength	λ_p	IF=30 mA	840	870	900	nm
Spectral half width	$\Delta\lambda$	IF=30 mA	-	45	-	nm
Light output*1	Pe	IF=30 mA	1.25	1.6	-	mW
Forward voltage	VF	IF=30 mA	-	1.5	1.65	V
Reverse current	IR	VR=5 V	-	-	5	μ A
Light spot size*2	Bw	IF=30 mA	4.0*3	4.3	-	mm
Cutoff frequency*4	fc	IF=30 mA \pm 4 mAp-p	25	40	-	MHz

*1: Measured with a photodiode (photosensitive area: $\phi 8$ mm) installed 25 mm away from LED stem undersurface

*2: Full width at half maximum of beam spot measured with an image sensor installed 13 mm away from LED stem undersurface

*3: Reference value

*4: Frequency at which the optical output drops by 3 dB from that at 100 kHz

Emission spectrum

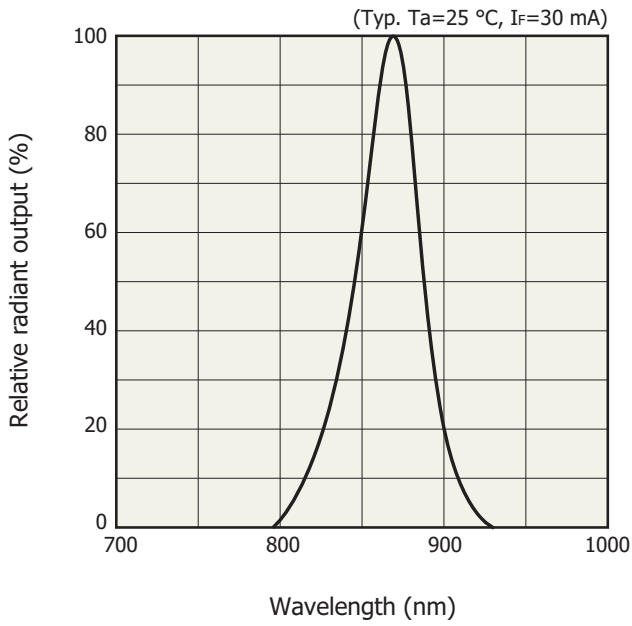

KLEDB0218EA

Optical output vs. forward current

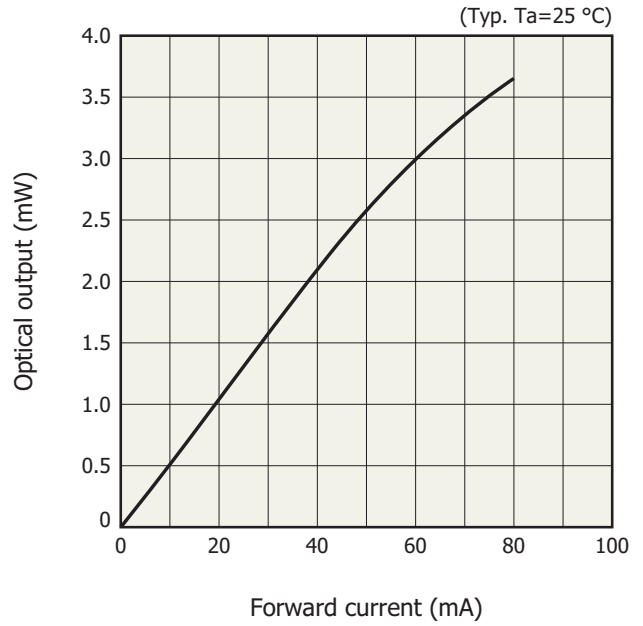

KLEDB0303EA

Forward current vs. forward voltage

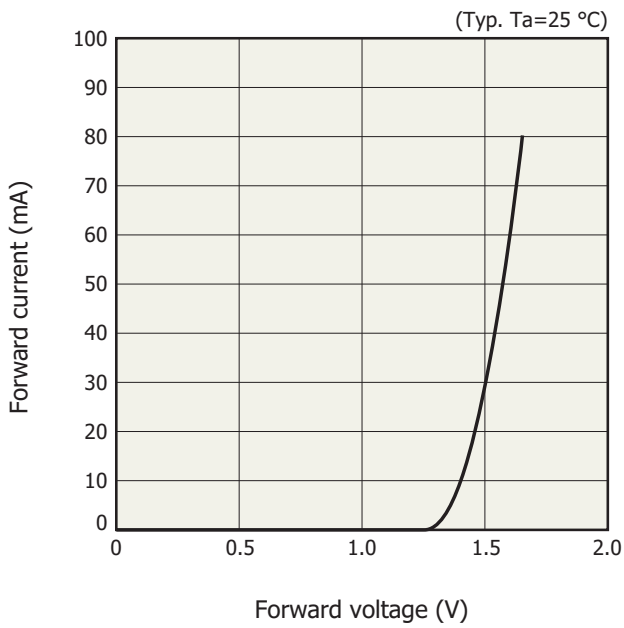

KLEDB0227EC

Directivity

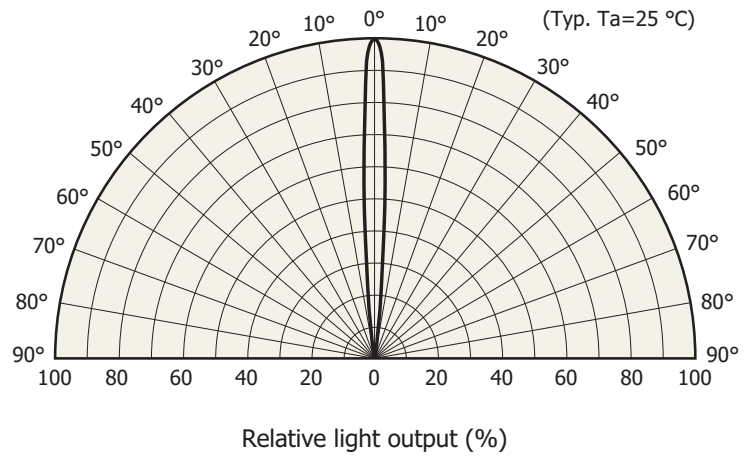

KLEDB0226EB

Light output vs. ambient temperature

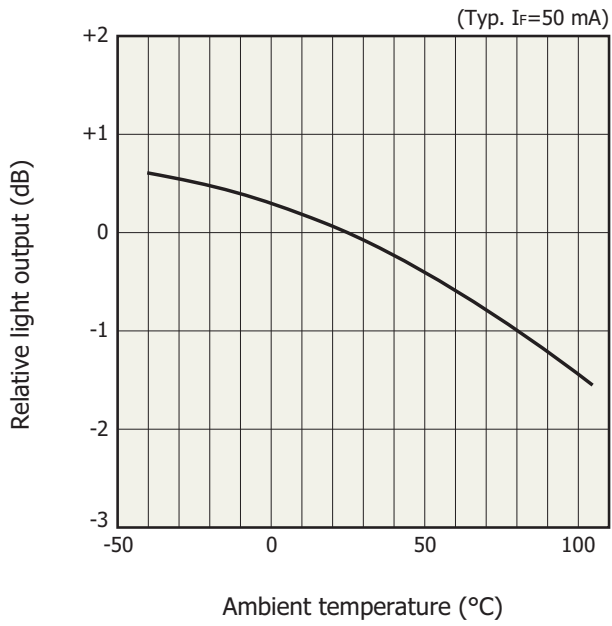

KLEDB0228EB

Allowable forward current vs. ambient temperature

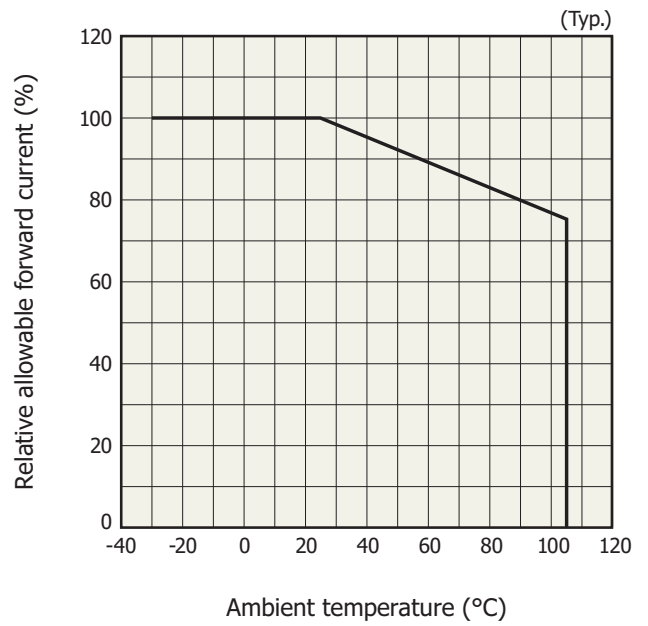

KLEDB0229EC

Light output distribution

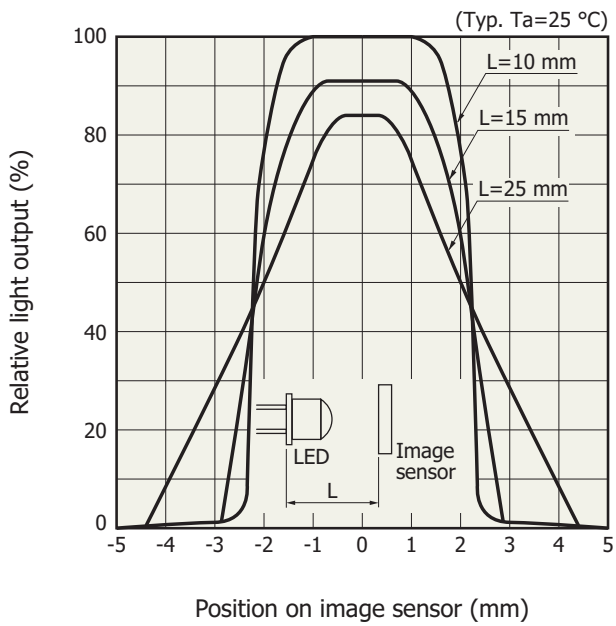

KLEDB0263EB

Dimensional outline (unit: mm)

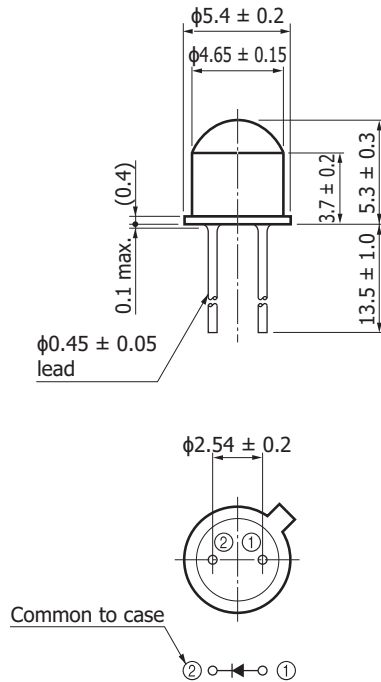

KLEDA0082EB

Related information

www.hamamatsu.com/sp/ssd/doc_en.html

■ Precautions

- Disclaimer
- Metal, ceramic, plastic products

Information described in this material is current as of July 2017.

Product specifications are subject to change without prior notice due to improvements or other reasons. This document has been carefully prepared and the information contained is believed to be accurate. In rare cases, however, there may be inaccuracies such as text errors. Before using these products, always contact us for the delivery specification sheet to check the latest specifications.

The product warranty is valid for one year after delivery and is limited to product repair or replacement for defects discovered and reported to us within that one year period. However, even if within the warranty period we accept absolutely no liability for any loss caused by natural disasters or improper product use. Copying or reprinting the contents described in this material in whole or in part is prohibited without our prior permission.

HAMAMATSUwww.hamamatsu.com

HAMAMATSU PHOTONICS K.K., Solid State Division

1126-1 Ichino-cho, Higashi-ku, Hamamatsu City, 435-8558 Japan, Telephone: (81) 53-434-3311, Fax: (81) 53-434-5184

U.S.A.: Hamamatsu Corporation: 360 Foothill Road, Bridgewater, N.J. 08807, U.S.A., Telephone: (1) 908-231-0960, Fax: (1) 908-231-1218

Germany: Hamamatsu Photonics Deutschland GmbH: Arzbergerstr. 10, D-82211 Herrsching am Ammersee, Germany, Telephone: (49) 8152-375-0, Fax: (49) 8152-265-8

France: Hamamatsu Photonics France S.A.R.L.: 19, Rue du Saule Trapu, Parc du Moulin de Massy, 91882 Massy Cedex, France, Telephone: 33-(1) 69 53 71 00, Fax: 33-(1) 69 53 71 10

United Kingdom: Hamamatsu Photonics UK Limited: 2 Howard Court, 10 Tewin Road, Welwyn Garden City, Hertfordshire AL7 1BW, United Kingdom, Telephone: (44) 1707-294888, Fax: (44) 1707-325777

North Europe: Hamamatsu Photonics Norden AB: Torshamnsgatan 35 16440 Kista, Sweden, Telephone: (46) 8-509-031-00, Fax: (46) 8-509-031-01

Italy: Hamamatsu Photonics Italia S.r.l.: Strada della Moia, 1 int. 6, 20020 Arese (Milano), Italy, Telephone: (39) 02-93581733, Fax: (39) 02-93581741

China: Hamamatsu Photonics (China) Co., Ltd.: B1201, Jiaming Center, No.27 Dongsanhuan Beilu, Chaoyang District, Beijing 100020, China, Telephone: (86) 10-6586-6006, Fax: (86) 10-6586-2866