

THE INFORMATION CONTAINED HEREIN IS CONSIDERED "PROPRIETARY" TO BEL FUSE INC. AND SHALL NOT BE COPIED, REPRODUCED OR DISCLOSED WITHOUT THE WRITTEN APPROVAL OF BEL FUSE INC.

LED 1 POLARITY			LED 2 POLARITY		
PIN 17	PIN 18	COLOR	PIN 19	PIN 20	COLOR
-	+	YELLOW	+	-	ORANGE
			-	+	GREEN

PRELIMINARY



**ELECTRICAL CHARACTERISTICS @ 25°C**

**URNS RATIO**  
 TP1 1CT : 1CT ±2%  
 TP2 1CT : 1CT ±2%  
 TP3 1CT : 1CT ±2%  
 TP4 1CT : 1CT ±2%

**DCL @ 100kHz/100mVRMS (4CHANNEL)**  
 8mA DC BIAS 180µH MIN.  
 23mA DC BIAS 120µH MIN.  
 Compliant to IEEE 802.3at specification

**INS. LOSS**  
 1MHz TO 150MHz -0.004(fMHz)-0.4 dB MAX

**RET. LOSS (MIN)**  
 1MHz-40MHz -20 dB  
 40.1MHz-150MHz -20+15LOG(f/40MHz) dB

**CROSSTALK**  
 1MHz - 40MHz -35 dB MIN  
 40.1MHz-150MHz -35+15LOG(f/40MHz) dB MIN

**CM TO CM REJ**  
 1MHz - 150MHz -25 dB MIN

**HIPOT (Isolation Voltage):** 2250 VDC  
 100% OF PRODUCTION TESTED TO COMPLY WITH IEEE 802.3 ISOLATION REQUIREMENTS

**BALANCED DC LINE CURRENT** 720 mA MAX. @ 57 VDC CONTINUOUS  
 1.2 A MAX. @ 57 VDC FOR 200 MILLISECONDS

**LED 1**  
 VF (FORWARD VOLTAGE) IF=20mA YELLOW 2.1V TYP.  
 λD (DOMINANT WAVELENGTH) IF=20mA YELLOW 590nm TYP.

**LED 2**  
 VF (FORWARD VOLTAGE) IF=20mA GREEN 2.2V TYP.  
 ORANGE 2.0V TYP.  
 λD (DOMINANT WAVELENGTH) IF=20mA GREEN 570nm TYP.  
 ORANGE 605nm TYP.

**OPERATING TEMPERATURE:** -40°C TO 85°C

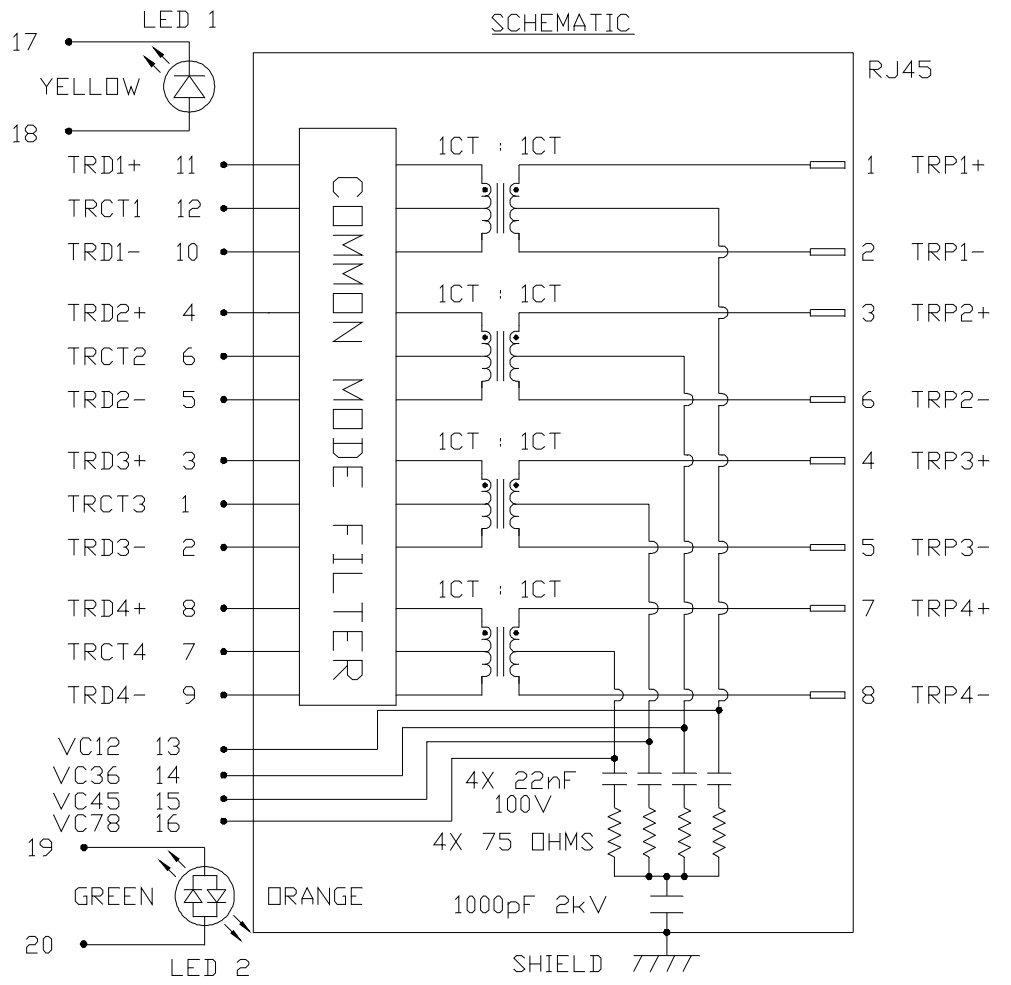

<b>ORIGINATED BY</b> CHOW WANCHUNG	<b>TITLE</b> 2.5 gigabit MagJack® (4PPoE, 100W, Extended Temp.)	<b>PART NO. / DRAWING NO.</b> 08261X1TKH-F	<b>STANDARD DIM.</b> TOL. IN INCH	<b>[ ] METRIC DIM.</b> AS REF.
<b>DATE</b> 2017-03-28		<b>FILE NAME</b> 08261X1TKH-F_PA.DWG	.X	UNIT : INCH [mm]
<b>DRAWN BY</b> XIE YIMING	0826-1X1T-KH-F PATENTED		.XX	SCALE : N/A
<b>DATE</b> 2017-03-28			.XXX	SIZE : A4

REV. : PA PAGE : 2

a bel group

Downloaded from Arrow.com

THE INFORMATION CONTAINED HEREIN IS CONSIDERED "PROPRIETARY" TO BEL FUSE INC. AND SHALL NOT BE COPIED, REPRODUCED OR DISCLOSED WITHOUT THE WRITTEN APPROVAL OF BEL FUSE INC.

PRELIMINARY

MECHANICAL SPECIFICATION



REMARK: NO TB TOOLING FOR SAMPLE BUILDING CURRENTLY.

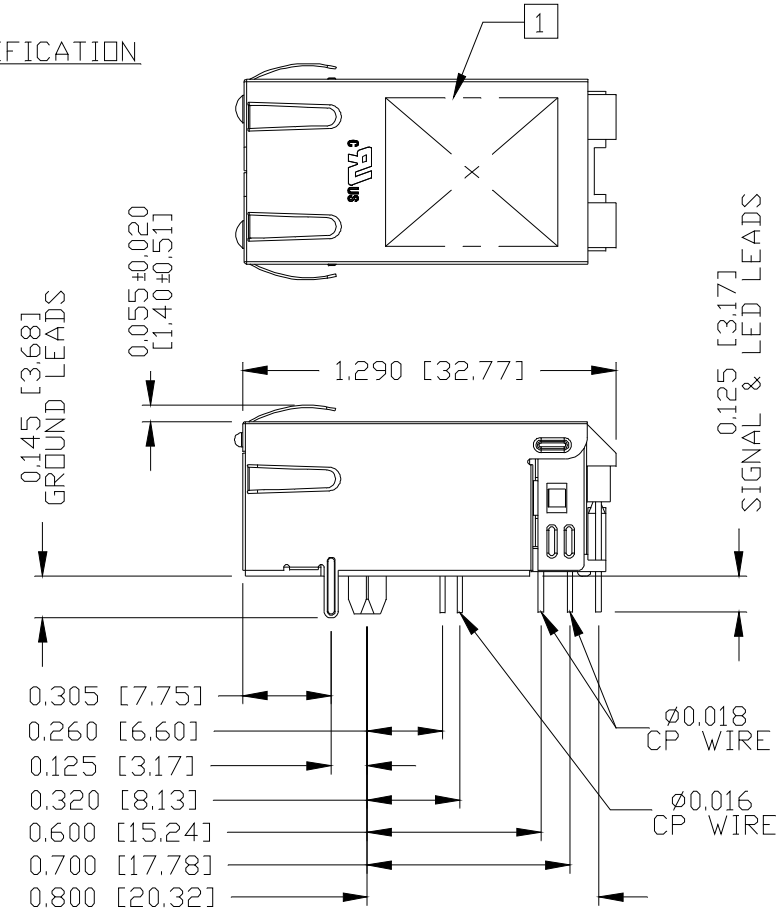
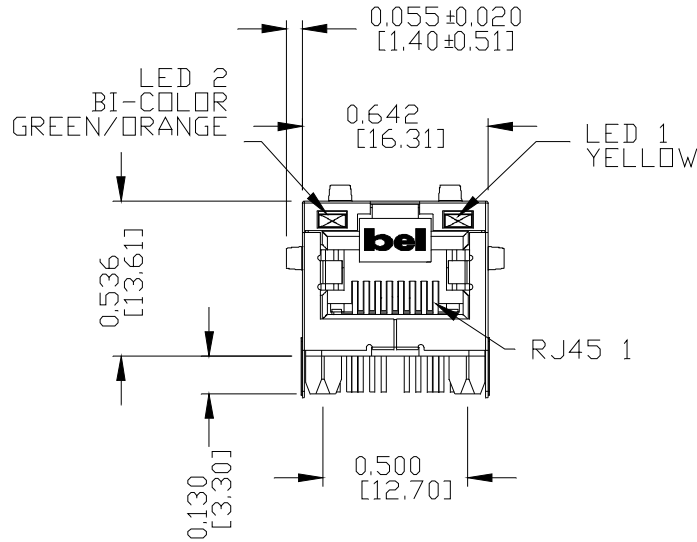

NOTES:

- PLASTIC HOUSING: THERMOPLASTIC PA, BLACK  
FLAMMABILITY RATING UL 94V-0
- CONTACTS: 50 MICRO-INCH HARD GOLD PLATING OR EQUIVALENT.
- OUTPUT PINS: TIN-COATED COPPER WIRE, DIA 0.016 AND DIA 0.018 INCH.  
100 MICRO-INCH MIN MATTE TIN. PINS ARE SOLDER DIPPED.
- METAL SHIELD: NICKEL PLATED ON COPPER ALLOY.  
(ALL GROUND LEADS ARE SOLDER DIPPED)

1. MARK PART WITH MFG LOGO, MFG NAME, PART NUMBER, DATE CODE AND PATENTED.

UL RECOGNIZED - FILE #E196366 AND E169987.

2. THE PRODUCT IS RoHS COMPLIANT.

- 3. JACK CAVITY CONFORMS TO FCC RULES AND REGULATIONS.
- 4. THE PRODUCT IS PATENTED, THE PATENT NUMBER IS U.S. PAT. 7,123,117.
- 5. THE PART IS RECOMMENDED FOR WAVE SOLDERING. THE SUGGESTED PEAK WAVE SOLDERING CONDITION IS 260°C MAX AND 10 SECONDS MAX.

REV. : PA PAGE : 3

ORIGINATED BY ANTON LIAO DATE 2017-03-28	TITLE 2.5 gigabit MagJack® (4PPoE, 100W, Extended Temp.)	PART NO. / DRAWING NO. 08261X1TKH-F		STANDARD DIM. TOL. IN INCH		[ ] METRIC DIM. AS REF.	
		FILE NAME 08261X1TKH-F_PA.DWG		.X		UNIT : INCH [mm]	
DRAWN BY JESSE LI DATE 2017-03-28	0826-1X1T-KH-F PATENTED			.XX		SCALE : N/A	
				.XXX	±0.010	SIZE : A4	



THE INFORMATION CONTAINED HEREIN IS CONSIDERED "PROPRIETARY" TO BEL FUSE INC. AND SHALL NOT BE COPIED, REPRODUCED OR DISCLOSED WITHOUT THE WRITTEN APPROVAL OF BEL FUSE INC.

PRELIMINARY

RoHS



RECOMMENDED PCB FOOTPRINT

COMPONENT SIDE VIEW

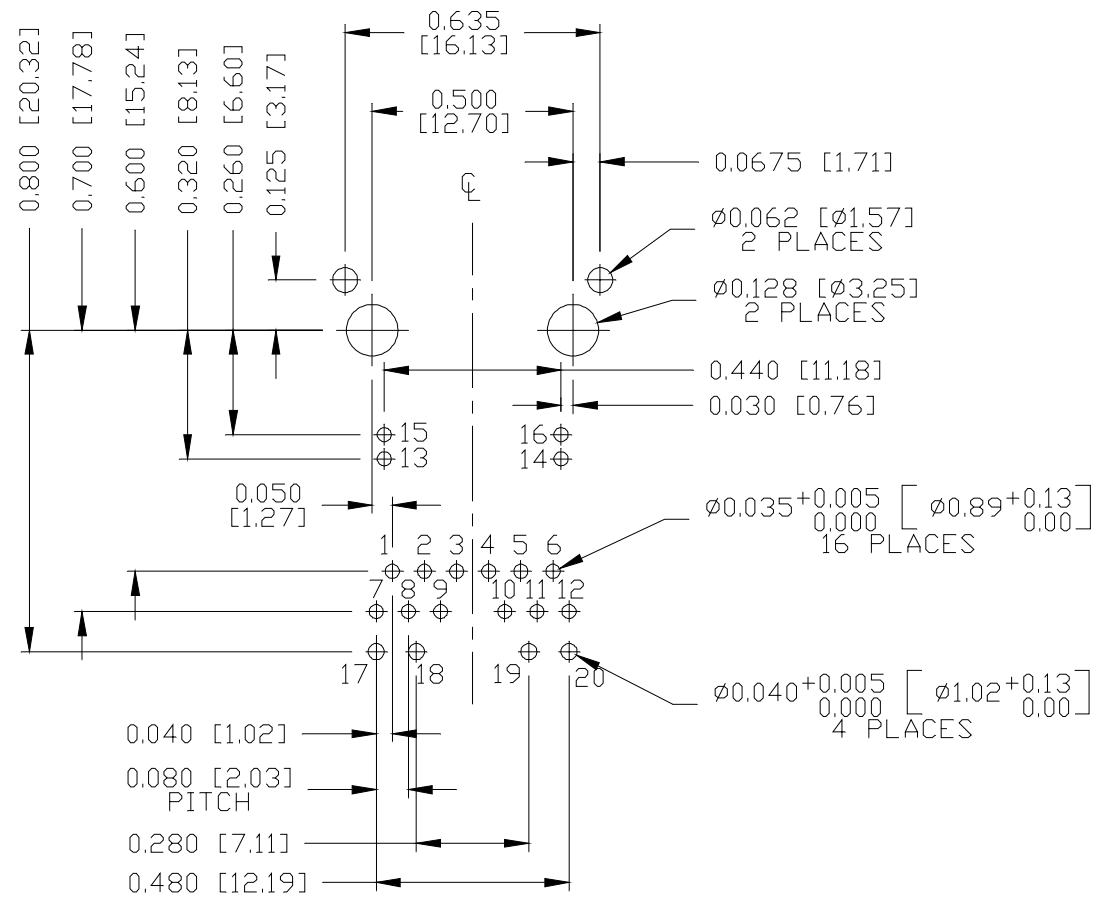
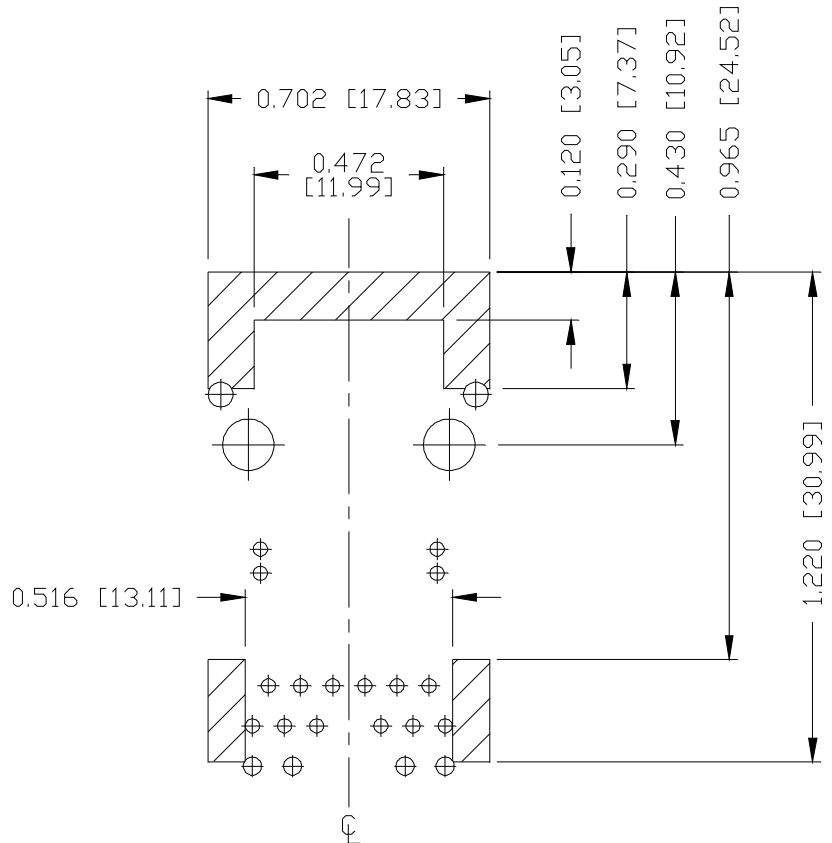

NOTES

THE SHADED AREA ON THE CUSTOMER BOARD ARE RECOMMENDED TO BE CLEAR OFF ANY VIA HOLE OR COMPONENT PAD.

REV. : PA PAGE : 4

ORIGINATED BY  
ANTON LIAO  
DATE 2017-03-28  
DRAWN BY  
JESSE LI  
DATE 2017-03-28

TITLE  
2.5 gigabit MagJack®  
(4PPoE, 100W, Extended Temp.)  
0826-1X1T-KH-F  
PATENTED

PART NO. / DRAWING NO.  
08261X1TKH-F  
FILE NAME  
08261X1TKH-F\_PA.DWG

STANDARD DIM.  
TOL. IN INCH  
.X  
.XX  
.XXX ±0.004  
[ ] METRIC DIM.  
AS REF.  
UNIT : INCH [mm]  
SCALE : N/A  
SIZE : A4



THE INFORMATION CONTAINED HEREIN IS CONSIDERED "PROPRIETARY" TO BEL FUSE INC. AND SHALL NOT BE COPIED, REPRODUCED OR DISCLOSED WITHOUT THE WRITTEN APPROVAL OF BEL FUSE INC.

SUGGESTED PANEL OPENING

PRELIMINARY

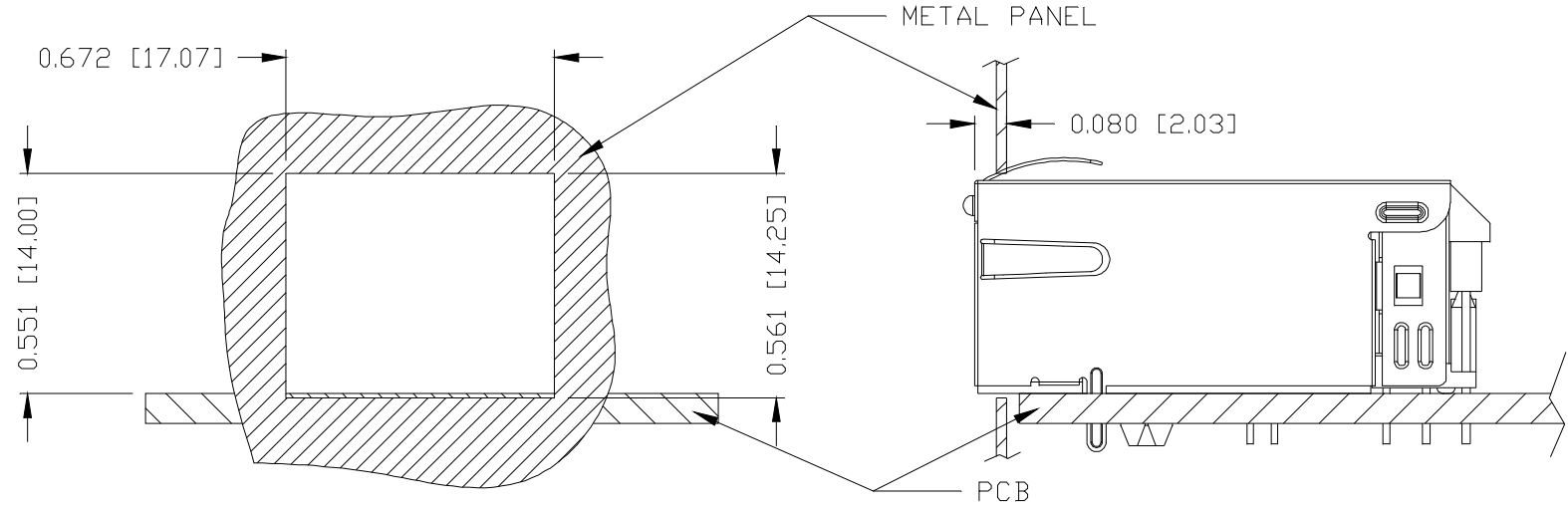

NOTE:

THE DISTANCE OF PANEL INSIDE SURFACE RELATIVE TO FRONT SURFACE OF PART IS ONLY A SUGGESTION. IN CASE THIS DISTANCE IS DIFFERENT, THE REQUIRED PANEL OPENING DIMENSIONS CHANGE ACCORDINGLY.

PACKING INFORMATION

PACKING TRAY : 0200-9999-F6 (TOP)  
0200-9999-F7 (BOTTOM)

PACKING QUANTITY : 40 PCS FINISHED GOODS PER TRAY  
10 TRAYS (400 PCS FINISHED GOODS) PER CARTON BOX

NOTE : CARDBOARDS ARE PLACED BETWEEN LAYERS OF PACKING TRAY INSIDE CARTON BOX  
(INCLUDE THE UPPERMOST AND LOWERMOST TRAY)

REV. : PA PAGE : 5

ORIGINATED BY ANTON LIAO DATE 2017-03-28  DRAWN BY JESSE LI DATE 2017-03-28	TITLE  2.5 gigabit MagJack® (4PPoE, 100W, Extended Temp.) 0826-1X1T-KH-F PATENTED	PART NO. / DRAWING NO. 08261X1TKH-F	STANDARD DIM. TOL. IN INCH	[ ] METRIC DIM. AS REF.		
		FILE NAME 08261X1TKH-F_PA.DWG	.X	UNIT : INCH [mm]		
			.XX	SCALE : N/A		
			.XXX	±0.004		SIZE : A4

