

LOC	DIST
FT	0

REVISIONS					
P	LTR	DESCRIPTION	DATE	DWN	APVD
	C4	PN 2-282959-0 RELEASED FOR PRODUCTION	04DEC2018	RK	PS
	C5	PART OBSOLETE	30JUL2021	GMN	PS

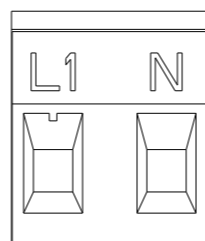

2-282959-0 AS SHOWN

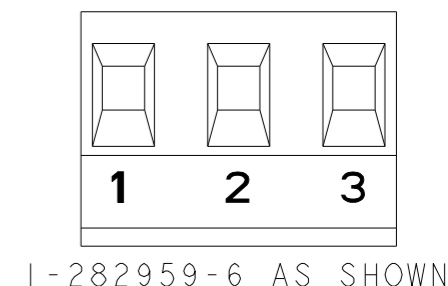
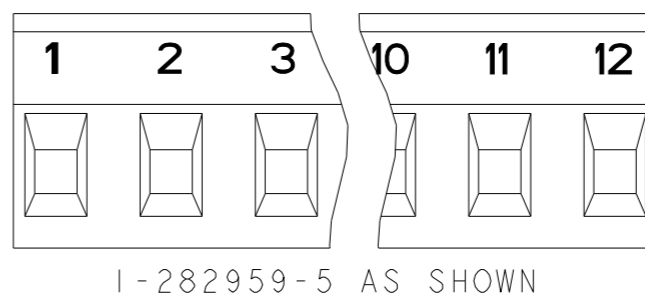
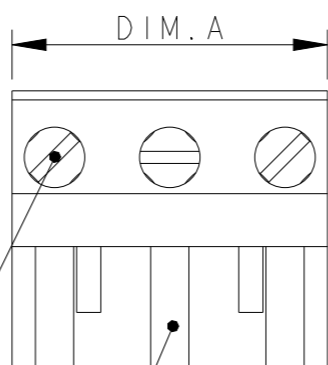
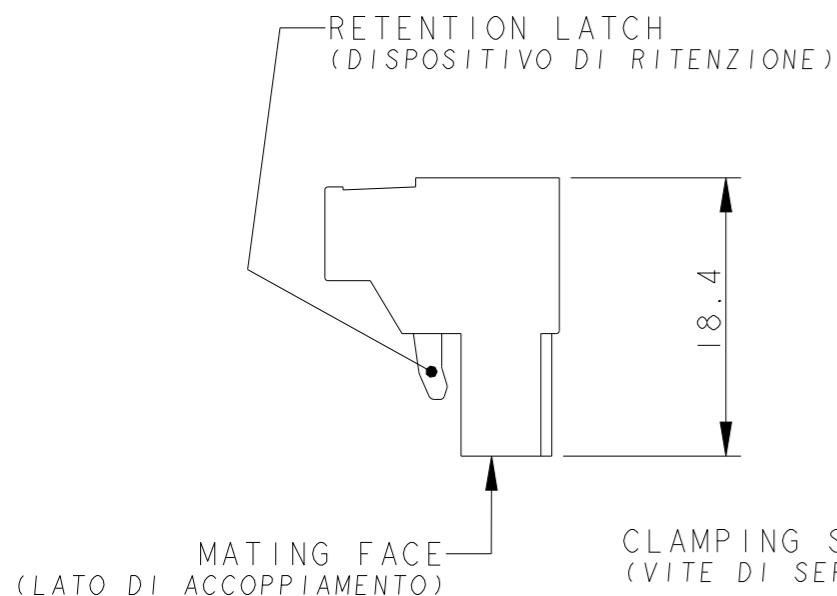
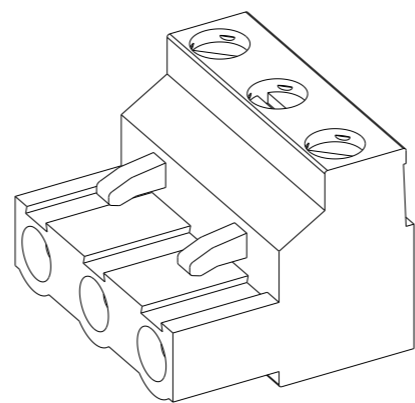

282959-3 AS SHOWN

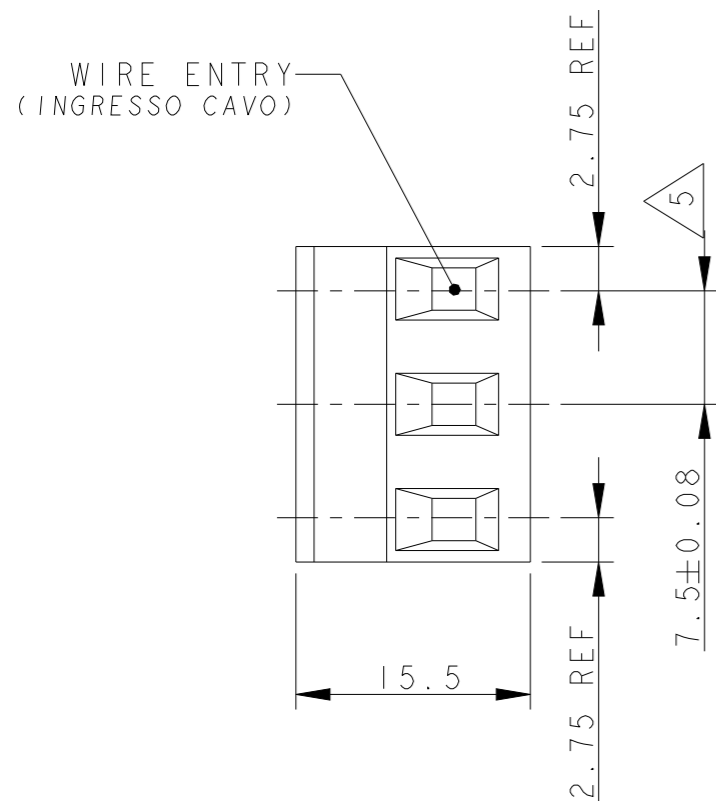

OBSOLETE

MARKING	COLOUR	DIM. A	NO OF POS.	PART NUMBER
AS SHOWN	GREEN	13.0	2	2-282959-0
/	GRAY	20.5	3	1-282959-9
AS SHOWN	GREEN	20.5	3	1-282959-6
AS SHOWN	GREEN	90.0	12	1-282959-5
/	GREEN	73.0	10	1-282959-4
/	BLACK	20.5	3	1-282959-3
/	GREEN	88.0	12	1-282959-2
/	GREEN	80.5	11	1-282959-1
/	GREEN	73.0	10	1-282959-0
/	GREEN	65.5	9	282959-9
/	GREEN	58.0	8	282959-8
/	GREEN	50.5	7	282959-7
/	GREEN	43.0	6	282959-6
/	GREEN	35.5	5	282959-5
/	GREEN	28.0	4	282959-4
/	GREEN	20.5	3	282959-3
/	GREEN	13.0	2	282959-2

THIS DRAWING IS A CONTROLLED DOCUMENT.	
DIMENSIONS: mm	TOLERANCES UNLESS OTHERWISE SPECIFIED:
	0 PLC ±-
	1 PLC ±0.2
	2 PLC ±0.20
	3 PLC ±0.001
	4 PLC ±0.0001
	ANGLES ±2
MATERIAL	FINISH

DWN	S. SCHLEGEL	25JUN96
CHK	R CANTORE	25JUN96
APVD	R CANTORE	25JUN96
PRODUCT SPEC	-	-
APPLICATION SPEC	-	-
WEIGHT	-	-
CUSTOMER DRAWING		

<b>STE</b> TE Connectivity			
NAME TERMINAL BLOCK PLUG, 7.5mm PITCH			
SIZE	CAGE CODE	DRAWING NO	RESTRICTED TO
A300779	C=282959	-	-
SCALE 2:1		SHEET 1 OF 2	REV C5

THIS DRAWING IS UNPUBLISHED.

RELEASED FOR PUBLICATION

20

© COPYRIGHT 20

ALL RIGHTS RESERVED.

LOC FT DIST 0

REVISIONS

P	LTR	DESCRIPTION	DATE	DWN	APVD
-		SEE SHEET 1	-	-	-

NOTES:

- MATERIALS AND FINISH  
HOUSING: PA 6-6, UL 94-V0.  
COLOURS: GRAY, RAL 7032.  
          BLACK.  
          GREEN.  
CLAMP: BRASS, NICKEL PLATED.  
DOUBLE SIDE CONTACT SPRING: PHOSPHOR BRONZE, TIN PLATED.  
CLAMPING SCREW: M3, BRASS, NICKEL PLATED.
- MECHANICAL  
MAX. INSERTION FORCE PER POLE : 3.0 N  
MIN. WITHDRAWAL FORCE PER POLE : 1.5 N  
WIRE STRIPPING LENGTH : 6.0-7.5 mm  
RECOMMENDED TIGHTENING TORQUE FOR SCREW : 0.5 Nm.
- ELECTRICAL  
WIRE RANGE : 12-30 AWG  
MAX. VOLTAGE : 300 V  
MAX CURRENT : 15 A  
CONTACT RESISTANCE : <15 m Ohm  
INSULATION RESISTANCE : >1000 M Ohm (500V DC)
- RECOGNIZED UNDER THE COMPONENT PROGRAM OF UNDERWRITERS LABORATORIES INC. FILE NO E60677.
- NOT CUMULATIVE TOLERANCE.
- INK MARKING : BLACK COLOUR  
NUMERICAL SEQUENCE : FROM LEFT TO RIGHT,  
WIRE ENTRY SIDE
- OPERATING TEMPERATURE RANGE: -40°C TO +105°C.

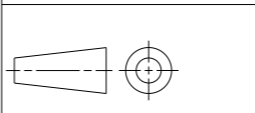
THIS DRAWING IS A CONTROLLED DOCUMENT.		DWN S. SCHLEGEL 25JUN96	<b>STE</b> TE Connectivity	
DIMENSIONS: mm		CHK R CANTORE 25JUN96		
TOLERANCES UNLESS OTHERWISE SPECIFIED:		APVD R CANTORE 25JUN96	NAME TERMINAL BLOCK PLUG, 7.5mm PITCH	
		PRODUCT SPEC -	- -	
MATERIAL -		APPLICATION SPEC -	SIZE A3	CAGE CODE 00779
FINISH -		WEIGHT -	DRAWING NO C-282959	RESTRICTED TO -
CUSTOMER DRAWING			SCALE 2:1	SHEET 2 OF 2
			REV C5	

# Mouser Electronics

Authorized Distributor

Click to View Pricing, Inventory, Delivery & Lifecycle Information:

[TE Connectivity:](#)

[282959-2](#)