

CBT250
BLE/NFC Hostless Module
Datasheet

Table of Contents

TRANSCEIVER IC	3
INTEGRATED FLASH	3
ABSOLUTE MAXIMUM RATINGS	3
RECOMMENDED OPERATING CONDITIONS	3
CURRENT CONSUMPTION	4
RF Receiver Specifications	4
RF Transmitter Specifications	4
I/O PIN ASSIGNMENTS	5
MODULE DIMENSIONS	6
MODULE LAND FOOTPRINT	6
AGENCY CERTIFICATIONS (PCB ANTENNA ONLY).....	9
ANTENNA.....	10
SHIPMENT, HANDLING AND STORAGE	11
QUALITY	11
ORDERABLE PART NUMBERS	12
REFERENCES.....	12
REVISION HISTORY	12
DISCLAIMER	12

TRANSCEIVER IC

The CBT250, utilizing the NXP QN9090 SoC, is a BLE/NFC combo device with integrated ARM Cortex™-M4 MCU core. This module supports BLE v5.0 while hosting the end-user application. The integrated NFC Forum Type 2 tag allows for easy network provisioning. The architecture is optimized for low-power consumption to provide the maximum battery life to smart devices. Customers can select from several supported RTOS implementations and interface to a variety of peripherals or external MCUs.

INTEGRATED FLASH

The CBT250 provides 640 kB of SoC-integrated program flash with an additional 8 Mb of on-module flash to support OTA FW updates and data-logging.

ABSOLUTE MAXIMUM RATINGS

Description	Min	Max	Unit
Storage temperature range	-40	125	°C
Power supply voltage (VDD)	3.0	3.6	V
I/O supply voltage	0.99	3.6	V
RF Input Power	-	10	dBm
Reflow Soldering Temperature	-	260	°C

RECOMMENDED OPERATING CONDITIONS

Description	Min	Typ	Max	Unit
Operating temperature range	-40	-	105	°C
Power supply voltage (VDD)	3.0	-	3.6	V

CURRENT CONSUMPTION

(@25°C unless otherwise specified; MCU usage for Application will increase current consumption; BLE Tx/Rx)

Operation Mode	Scenario	Min	Typical	Max	Unit
Deep Power-Down	Wake-Up on HW reset or an event on any of the GPIO/NTAG pins.	-	350	-	nA
Deep-Sleep	Wake-Up on HW reset or an IO event. Wake-Up Timer on; 32 kHz FRO on; 4 kB SRAM retention		1150		nA
RX Mode	MCU halted, I/O available, Radio ON		4.3		mA
TX Mode	Continuous Tx @ 0 dBm		7.4		mA
	Continuous Tx @ 10 dBm		20.3		

RF Receiver Specifications

(@25°C unless otherwise specified)

Parameter	Min	Typ	Max	Unit
Frequency Range	2400	-	2485	MHz
RX Sensitivity	-	-97	-	dBm

RF Transmitter Specifications

(@25°C unless otherwise specified)

Parameter	Min	Typ	Max	Unit
Frequency Range	2400	-	2485	MHz
Transmit Power (conducted)	-	10	-	dBm

I/O PIN ASSIGNMENTS

Module Pin Number	Pin Name	K32W061 Pin (Refer to NXP K32W061 datasheet for detailed functionality)
1	GND	
2	GND	
3	PIO20	24
4	RST	27
5	PIO3	6
6	PIO10	13
7	PIO6	9
8	PIO7	10
9	PIO5	8
10	PIO2	5
11	PIO1	4
12	GND	
13	VCC	
14	PIO0	3
15	PIO4	7
16	PIO11	14
17	PIO12	15
18	PIO13	16
19	PIO8	11
20	PIO9	12
21	PIO16	19
22	PIO15	18
23	PIO17	21
24	PIO18	22
25	PIO19	23
26	PIO20	24
27	PIO21	25
28	GND	
29	LB (NFC Input B)	39
30	LA (NFC Input A)	40
31	GND	
32	RF OUT	
33	GND	

MODULE DIMENSIONS

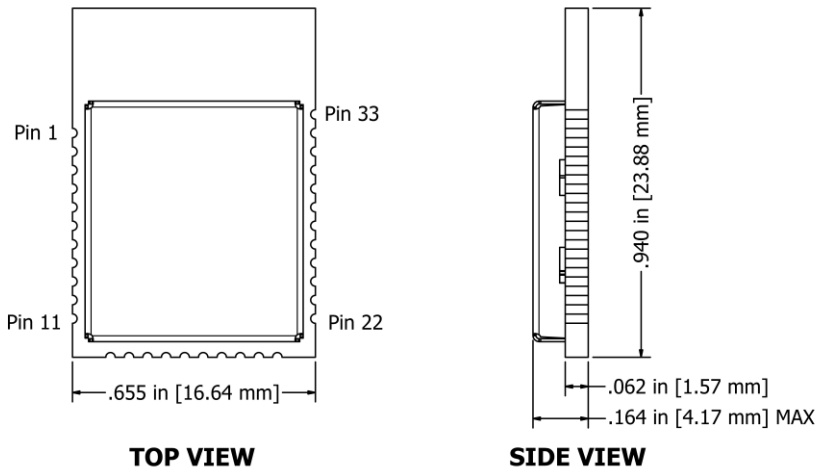

Note: All dimensions are ± .005 in [0.12 mm] unless otherwise specified

MODULE LAND FOOTPRINT

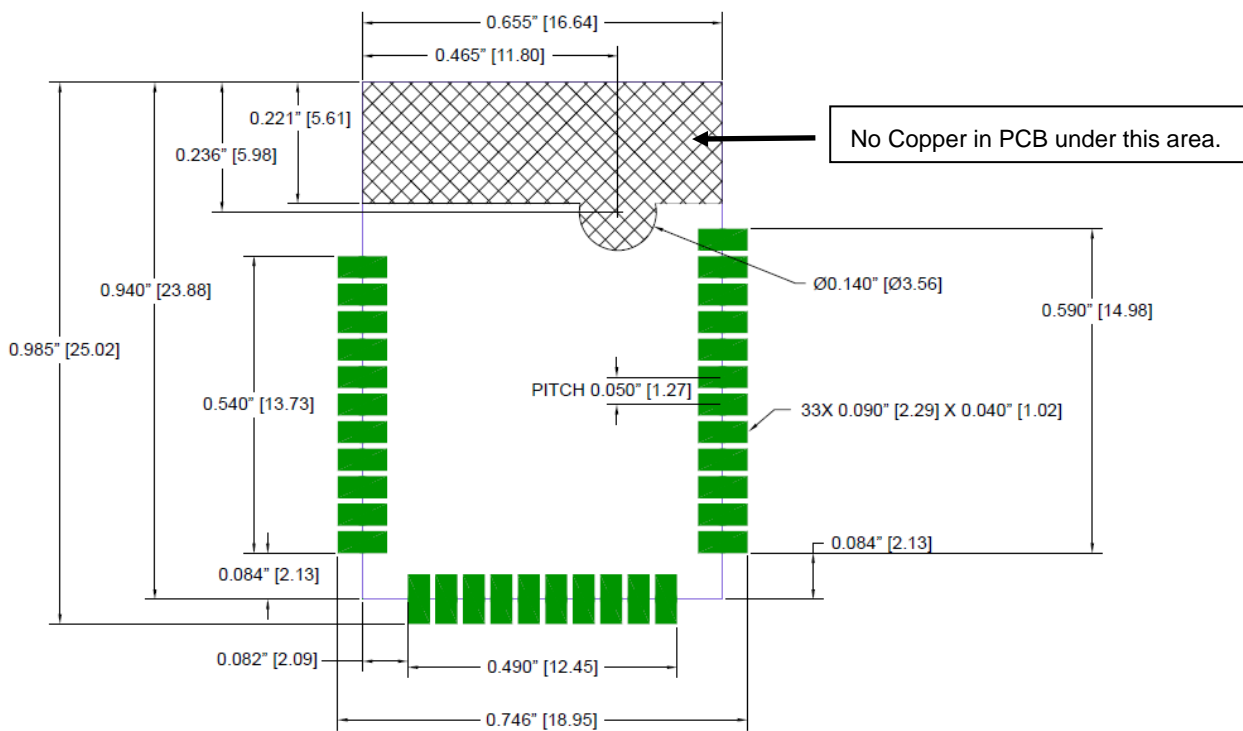

EVALUATION BOARD

Part Number: CBT250-1-EVB

The Evaluation Board functions stand-alone for module evaluation and Interfaces to the NXP IOTZTB-DK006 Advanced Development Kit for the K32W061 for advanced system development.

PROCESSING

Recommended Reflow Profile

Parameter Values	
Ramp Up Rate (from T_{soakmax} to T_{peak})	3°/sec max
Minimum Soak Temperature	150°C
Maximum Soak Temperature	200°C
Soak Time	60-120 sec
T_{Liquidus}	217°C
Time above TL	60-150 sec
T_{peak}	250°C
Time within 5° of T_{peak}	20-30 sec
Time from 25° to T_{peak}	8 min max
Ramp Down Rate	6°C/sec max

Pb-Free Solder Paste

Use of “No Clean” soldering paste is strongly recommended, as it does not require cleaning after the soldering process.

Note: *The quality of solder joints on the castellations (“half vias”) where they contact the host board should meet the appropriate IPC Specification. See the Castellated Terminations Section in the latest IPC-A-610 Acceptability of Electronic Assemblies document.*

Cleaning

In general, cleaning the populated module is strongly discouraged. Residuals under the module cannot be easily removed with any cleaning process.

- Cleaning with water can lead to capillary effects where water is absorbed into the gap between the host board and the module. The combination of soldering flux residuals and encapsulated water could lead to short circuits between neighboring pads. Water could also damage any stickers or labels.
- Cleaning with alcohol or a similar organic solvent will likely flood soldering flux residuals into the two housings, which is not accessible for post-washing inspection. The solvent could also damage any stickers or labels.
- Ultrasonic cleaning could damage the module permanently.

The best approach is to consider using a “No Clean” solder paste and eliminate the post-soldering cleaning step.

Optical Inspection

After soldering the module to the host board, consider optical inspection to check the following:

- Proper alignment and centering of the module over the pads
- Proper solder joints on all pads
- Excessive solder or contacts to neighboring pads or vias

Repeating Reflow Soldering

Only a single reflow soldering process is encouraged for host boards.

Wave Soldering

If a wave soldering process is required on the host boards due to the presence of leaded components, only a single wave soldering process is encouraged.

Hand Soldering

Hand soldering is possible. When using a soldering iron, follow IPC recommendations (reference document *IPC-7711*).

Rework

The CBT250 modules can be unsoldered from the host board. Use of a hot air rework tool should be programmable and the solder joint and module should not exceed the maximum peak reflow temperature of 250°C.

Caution

If temperature ramps exceed the reflow temperature profile, module and component damage may occur due to thermal shock. Avoid overheating.

Warning

Never attempt a rework on the module itself (i.e., replacing individual components); such actions will terminate warranty coverage.

Additional Grounding

Attempts to improve the module or the system grounding by soldering braids, wires or cables onto the module RF shield cover is done at the customer's own risk. The ground pins at the module perimeter should be sufficient for optimum immunity to external RF interference.

AGENCY CERTIFICATIONS (PCB ANTENNA ONLY)

The following certifications are in effect for the CBT250 modules:

- FCC
- IC
- CE

FCC Compliance Statement Part 15.19, Section 7.15 of RSS-GEN **PENDING**

This device complies with Part 15 of the FCC Rules and with Industry Canada license-exempt RSS Standards. Operation is subject to the following two conditions:

1. This device may not cause harmful interference.
2. This device must accept any interference received, including interference that may cause undesired operation.

Le présent appareil est conforme aux CNR d'Industrie Canada applicables aux appareils radio exempts de licence. L'exploitation est autorisée aux deux conditions suivantes:

1. l'appareil ne doit pas produire de brouillage, et
2. l'utilisateur de l'appareil doit accepter tout brouillage radioélectrique subi, même si le brouillage est susceptible d'en compromettre le fonctionnement.

Warning (Part 15.21)

Changes or modifications not expressly approved by CEL could void the user's authority to operate the equipment.

20 cm Separation Distance

To comply with FCC/IC RF exposure limits for general population/uncontrolled exposure, the antenna(s) used for this transmitter must be installed to provide a separation distance of at least 20 cm from all persons and must not be co-located or operating in conjunction with any other antenna or transmitter.

OEM Responsibility to the FCC and IC Rules and Regulations

The CBT250 modules have been certified per FCC Part 15 Rules and to Industry Canada license-exempt RSS Standards for integration into products without further testing or certification. To fulfill the FCC and IC Certification requirements, the OEM of the CBT250 must ensure that the information provided on the CBT250 label is placed on the outside of the final product. The CBT250 is labeled with its own FCC ID Number and IC ID Number. If the FCC ID and the IC ID are not visible when the module is installed inside another device, then the outside of the device into which the module is installed must also display a label referring to the enclosed module. The exterior label can use wording such as the following:

"Contains Transmitter Module FCC ID: W7Z-ZB220501" or "Contains FCC ID: W7Z-ZB220501"

"Contains Transmitter Module IC: 8254A-ZB220501" or "Contains IC: 8254A-ZB220501"

The OEM of the CBT250 may only use the approved antenna (PCB trace antenna) that has been certified with this module. The OEM of the CBT250 must test their final product configuration to comply with Unintentional Radiator Limits before declaring FCC Compliance per Part 15 of the FCC Rules.

IC Certification — Industry Canada Statement **PENDING**

The term "IC" before the certification/registration number only signifies that the Industry Canada technical specifications were met.

Certification IC - Déclaration d'Industrie Canada

Le terme "IC" devant le numéro de certification/d'enregistrement signifie seulement que les spécifications techniques Industrie Canada ont été respectées.

Section 14 of RSS-210

The installer of this radio equipment must ensure that the antenna is located or pointed such that it does not emit RF field in excess of Health Canada limits for the general population. Consult Safety Code 6, obtainable from Health Canada's website: <http://www.hc-sc.gc.ca/ewh-semt/pubs/radiation/99ehd-dhm237/index-eng.php>

L'article 14 du CNR-210

Le programme d'installation de cet équipement radio doit s'assurer que l'antenne est située ou orientée de telle sorte qu'il ne pas émettre de champ RF au-delà des limites de Santé Canada pour la population générale. Consulter le Code de sécurité 6, disponible sur le site Web de Santé Canada: <http://www.hc-sc.gc.ca/ewh-semt/pubs/radiation/99ehd-dhm237/index-eng.php>

ANTENNA

CEL's CBT250 modules include an integrated Printed Circuit Board (PCB) trace antenna. An optional configuration which uses an RF pin on the module allows the user to connect an external antenna. The CBT250 modules have been certified with the PCB trace antenna only.

The PCB antenna employs a topology that is compact and highly efficient. To maximize range, an adequate ground plane must be provided on the host PCB. Correctly positioned, the ground plane on the host PCB will contribute significantly to the antenna performance (it should not be directly under the module PCB antenna). The position of the module on the host board and overall design of the product enclosure contribute to antenna performance. Poor design affects radiation patterns and can result in reflection, diffraction and/or scattering of the transmitted signal.

For optimum antenna performance, the CBT250 should be mounted with the PCB trace antenna overhanging the edge of the host board. To further improve performance, a ground plane may be placed on the host board under the module; up to the antenna (a minimum of 1.5" x 1.5" is recommended). The installation of an uninterrupted ground plane on a layer directly beneath the module will also allow you to run traces under this layer. CEL can assist with your PCB layout.

The following are some design guidelines to help ensure antenna performance:

- Never place the ground plane or route copper traces directly underneath the antenna portion of the module
- Never place the antenna close to metallic objects
- In the overall design, ensure that wiring and other components are not placed near the antenna
- Do not place the antenna in a metallic or metalized plastic enclosure
- Keep plastic enclosures 1cm or more away from the antenna in any direction

Under Industry Canada regulations, this radio transmitter may only operate using an antenna of a type and maximum (or lesser) gain approved for the transmitter by Industry Canada. To reduce potential radio interference to other users, the antenna type and its gain should be so chosen that the equivalent isotropically radiated power (e.i.r.p.) is not more than that necessary for successful communication.

Conformément à la réglementation d'Industrie Canada, le présent émetteur radio peut fonctionner avec une antenne d'un type et d'un gain maximal (ou inférieur) approuvé pour l'émetteur par Industrie Canada. Dans le but de réduire les risques de brouillage radioélectrique à l'intention des autres utilisateurs, il faut choisir le type d'antenne et son gain de sorte que la puissance isotrope rayonnée équivalente (p.i.r.e.) ne dépasse pas l'intensité nécessaire à l'établissement d'une communication satisfaisante.

SHIPMENT, HANDLING AND STORAGE

Shipment

The CBT250 modules are delivered in tape and reel. Each reel contains 600 modules.

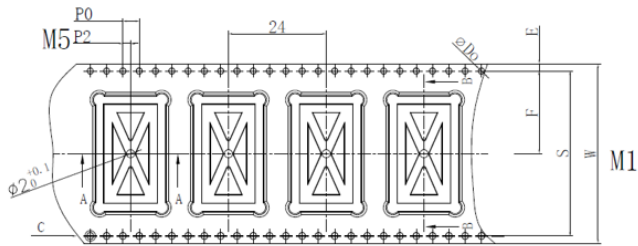

E	1.75 ± 0.10
F	20.20 ± 0.15
S	40.40 ± 0.10
P2	2.00 ± 0.15
ϕD_0	$1.50 \pm \begin{smallmatrix} 0.10 \\ 0.00 \end{smallmatrix}$
ϕD_1	$2.00 \pm \begin{smallmatrix} 0.10 \\ 0.00 \end{smallmatrix}$
P0	4.00 ± 0.10
10P0	40.00 ± 0.20
W	44.00 ± 0.30
P	24.00 ± 0.10
A0	17.04 ± 0.10
B0	28.20 ± 0.10
K0	4.27 ± 0.10
T	0.40 ± 0.05

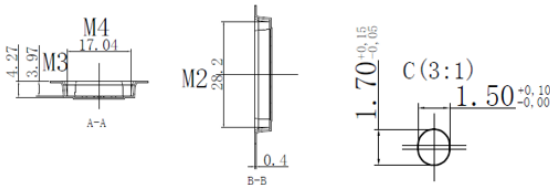

Handling

The CBT250 modules are designed and packaged to be processed in an automated assembly line.

Warning

The CBT250 modules contain highly sensitive electronic circuitry. Handling without proper ESD protection may destroy or damage the module permanently.

Warning

The CBT250 modules are moisture-sensitive devices. Appropriate handling instructions and precautions are summarized in J-STD-033. Read carefully to prevent permanent damage due to moisture intake.

Moisture Sensitivity Level (MSL)

MSL 3, per J-STD-033

Storage

Storage/shelf life in sealed bags is 12 months at $<40^{\circ}\text{C}$ and $<90\%$ relative humidity.

QUALITY

CEL Modules offer the highest quality at competitive prices. Our modules are manufactured in compliance with the IPC-A-610 specification, Class II. Our modules go through JESD22 qualification processes which includes high temperature operating life tests, mechanical shock, temperature cycling, humidity and reflow testing. CEL conducts RF and DC factory testing on 100% of all production parts.

CEL builds the quality into our products, giving our customers confidence when integrating our products into their systems.

ORDERABLE PART NUMBERS

Orderable Part Number	Description	Min/Mult
CBT250-1-R	QN9090, BLE+NFC, 8 MB flash, PCB antenna, 10 dBm	600/600
CBT250-1C-R	QN9090, BLE+NFC, 8 MB flash, RF pin, 10 dBm	600/600
CBT250-1-EVB	Evaluation Board, CBT250, 8 Mb flash, PCB antenna, 10 dBm	1/1

REFERENCES

Reference Documents	Download
Health Canada Safety Code 6	Link

REVISION HISTORY

Revision	Changes to Current Version	Page(s)
0029-00-07-00-000 (Issue A) Sept 28, 2020	Initial Preliminary Data Sheet	N/A
0054-00-07-00-000 (Issue B) May 24, 2021	Update document number, correct orderable PN table, clarify flash density	
0054-00-07-00-000 (Issue C) Dec 1, 2022	Update orderable PN table. Add certification information.	9, 12

DISCLAIMER

The information in this document is current as of the published date. The information is subject to change without notice. For actual design-in, refer to the latest publications of CEL Data Sheets or Data Books, etc., for the most up-to-date specifications of CEL products. Not all products and/or types are available in every country. Please check with a CEL sales representative for availability and additional information.

No part of this document may be copied or reproduced in any form or by any means without the prior written consent of CEL. CEL assumes no responsibility for any errors that may appear in this document.

CEL does not assume any liability for infringement of patents, copyrights or other intellectual property rights of third parties by or arising from the use of CEL products listed in this document or any other liability arising from the use of such products. No license, express, implied or otherwise, is granted under any patents, copyrights or other intellectual property rights of CEL or others.

Descriptions of circuits, software and other related information in this document are provided for illustrative purposes in semiconductor product operation and application examples. The incorporation of these circuits, software and information in the design of a customer's equipment shall be done under the full responsibility of the customer. CEL assumes no responsibility for any losses incurred by customers or third parties arising from the use of these circuits, software and information.

FOR MORE INFORMATION

For more information about CEL wireless products and solutions, visit our website at www.cel.com/.

TECHNICAL ASSISTANCE

For Technical Assistance, please contact us at wirelessmodules@cel.com

Mouser Electronics

Authorized Distributor

Click to View Pricing, Inventory, Delivery & Lifecycle Information:

[CEL:](#)

[CBT250-1C-R](#) [CBT250-1-EVB](#) [CBT250-1-R](#)