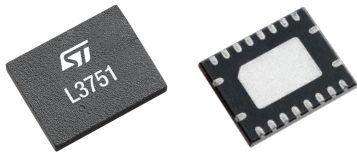


## Wide 6 V to 75 V input voltage synchronous buck controller

### Features



#### Maturity status link

A6983I

- Wide 6 V to 75 V input voltage range
- Adjustable output voltage from 0.8 V to 60 V
- 100 kHz - 1 MHz switching frequency range
- 40 nsec minimum on-time for extreme duty ratio
- Low dropout operation during line transient
- Adjustable soft-start or input voltage tracking
- Pulse skipping or forced PWM operation at light load
- Synchronization
- Adjustable precision enable
- Power Good open collector output validates  $V_{OUT}$
- 7.5 V gate drivers for standard  $V_{TH}$  MOSFETs
- Constant current protection with hiccup mode
- Precision or lossless programmable current sensing
- Improved line transient response
- Input voltage undervoltage lockout
- Internal voltage monitoring
- Thermal protection
- Operating junction temperature range: -40 °C to 150 °C

### Applications

- Telecom, networking and industrial applications
- Failsafe systems
- Unregulated 24 V and 48 V input voltage bus
- Conversion from high voltage battery to 12 V and 5 V rail

### Description

The 6 V to 75 V wide input voltage range L3751 synchronous buck controller features extreme voltage conversion ratio over switching frequency range (100 kHz - 1 MHz) thanks to 40 nsec minimum conduction time.

The diode emulation (DEM) implements pulse skipping mode that maximizes the efficiency at light-load giving controlled output voltage ripple. The forced PWM (FPWM) over the load range makes the switching frequency constant and minimizes the output voltage ripple.

The Power Good open collector output validates the regulated output voltage for monitoring and it is useful to implement output voltage sequencing for digital ICs during the power-up phase.

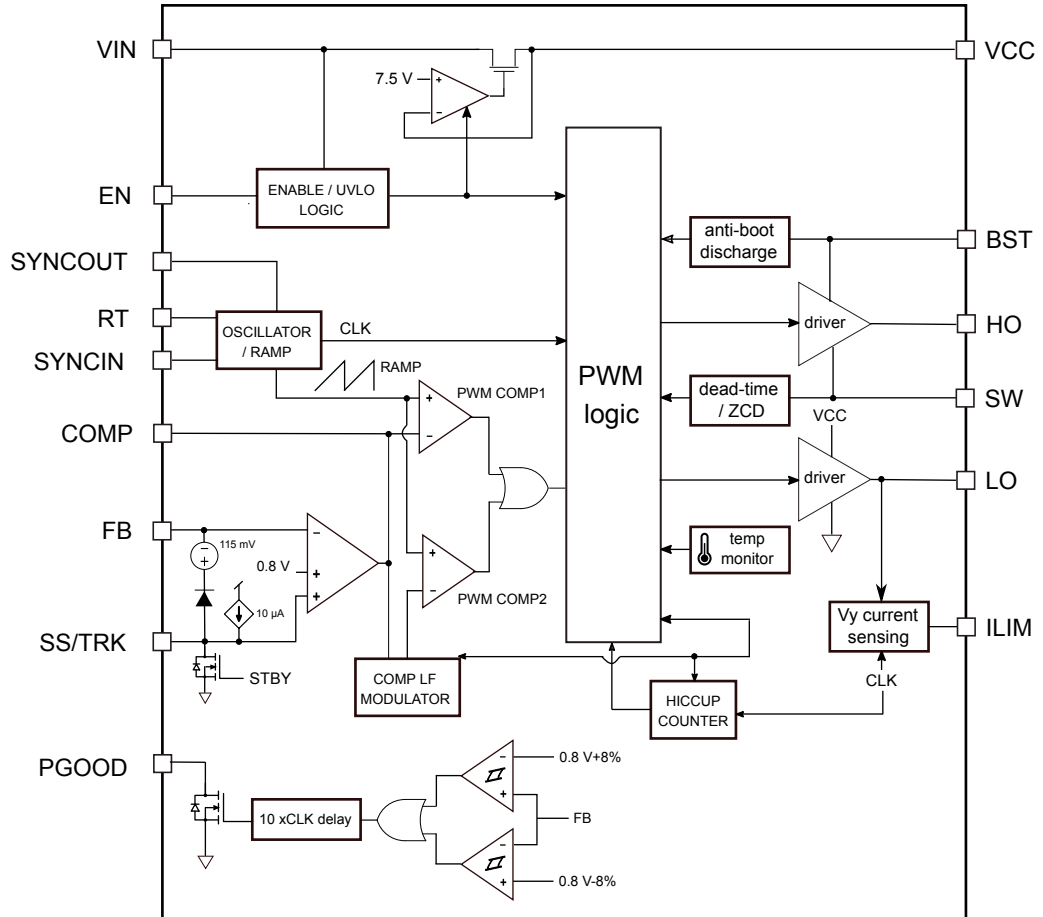
An embedded gate driver minimizes the number of external components and it is designed for standard  $V_{TH}$  MOSFET.

Embedded protections—output overcurrent, input voltage UVLO, internal voltage monitoring, thermal shutdown - feature controlled and safe operation for critical environments in telecom, networking and industrial applications.

The device is available in a QFN 20 leads 3.5 x 4.5 mm package with wettable flanks.

1 Diagram

Figure 1. Simplified block diagram



## 2 Pin configuration

Figure 2. QFN pin connection (top view)

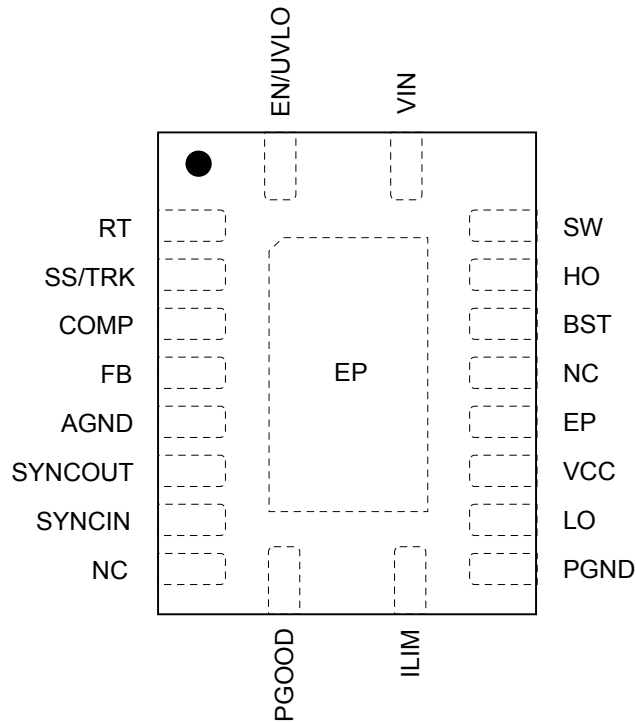


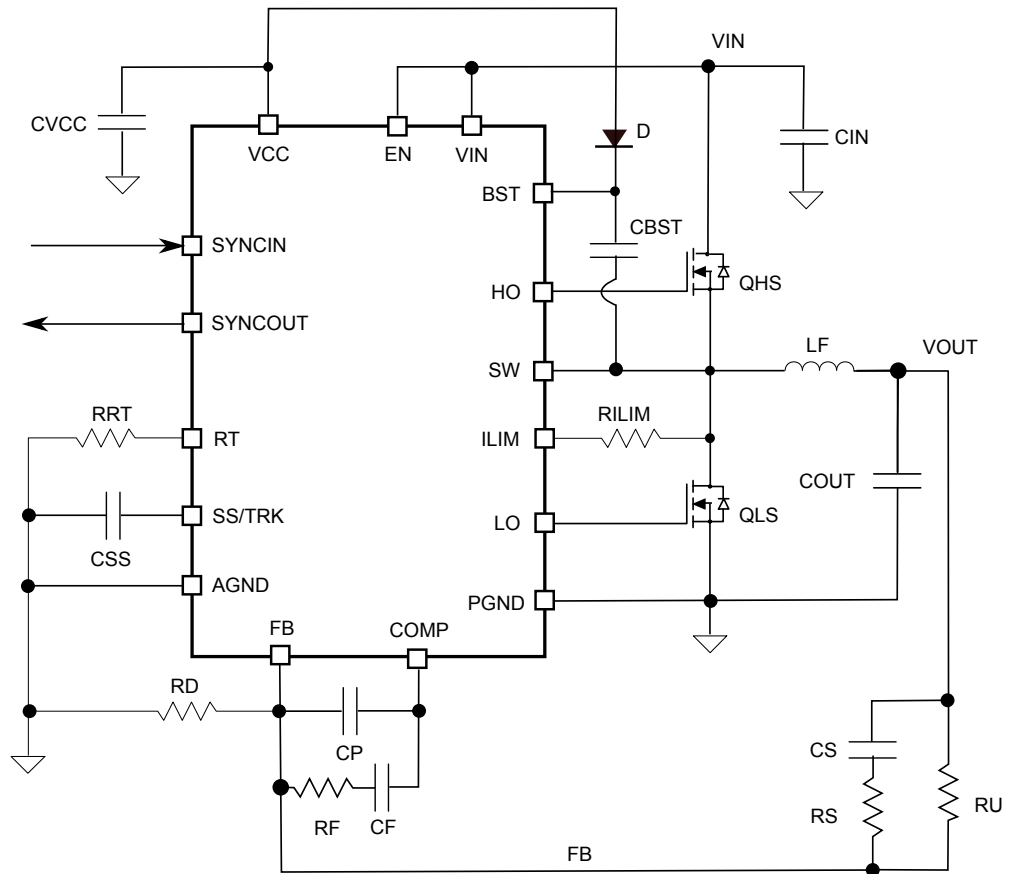
Table 1. Pin description

QFN Pin	Die PAD	Name	Function
1		EN/UVLO	<p>The central tap of a resistor divider connected to this pin helps to design the enable and undervoltage lockout thresholds referred to the input voltage.</p> <ul style="list-style-type: none"> <li><math>V_{EN/UVLO} &lt; 0.4</math> typ.: the device is in shutdown mode</li> <li><math>0.4</math> V typ. <math>&lt; V_{EN/UVLO} &lt; 1.2</math> V typ.: device in standby - VCC regulator active - SS/TRK pin in low impedance</li> <li><math>V_{EN/UVLO} &gt; 1.2</math> V typ.: SS/TRK pin released and the device ready to start - <math>10 \mu\text{A}</math> current flows to the external resistor divider to design the enable hysteresis.</li> </ul>
2		RT	A pull-down resistor to AGND programs the oscillator frequency (100 kHz – 1 MHz) and adjust the internal ramp for constant PWM gain.
3		SS/TRK	The pin circuitry features a current generator (10 $\mu\text{A}$ typ.) to charge an external capacitor and so program the soft-start time, otherwise it implements voltage tracking if connected to an auxiliary voltage source. In soft-start phase, the SS/TRK voltage is the error amplifier reference and then the internal reference becomes active after the startup phase has ended. The pin is clamped 115 mV above the FB voltage for controlled recovery from an overcurrent event or clamped to ground during stand-by operation or internal fault.
4		COMP	Output of the internal error amplifier. Connect the compensation network between COMP and the FB.
5		FB	Inverting input of the internal error amplifier. Connect the compensation network between COMP and the FB.
6		AGND	Analog ground
7		SYNCOUT	Synchronization output implements 180° phase shifted referred to HO driving signal if the regulator is master. If synchronized to an external clock the signal is in phase with SYNCIN.

QFN Pin	Die PAD	Name	Function
8		SYNCIN	Synchronization input and DEM (Diode Emulation) / FPWM (Forced PWM) selection. The device always implements DEM during soft-start to support pre-charged output capacitor at device startup. Low logic level selects DEM, high logic level or synchronization clock input enables the forced PWM. The device features a smooth transition DEM to FPWM thanks to embedded dedicated circuitry.
9		NC	Not internally connected
10		PGOOD	Power Good output collector is driven in low impedance when the FB voltage is out of the regulation window.
11		ILIM	Valley current limit adjust and current sense comparator input. A series resistor programs valley current threshold for accurate sensing across external sensing resistor or lossless sensing directly on the drain of the low-side MOSFET.
12		PGND	Power ground
13		LO	Low-side MOSFET gate drive output. Optional series resistor may be connected to adjust switching times for EMI compatibility.
14		VCC	Output of the internal 7.5 V linear regulator that powers the embedded voltage gate driver. Connect high quality mlcc capacitor ( $470\text{ nF} \leq \text{CVCC} \leq 2\text{ }\mu\text{F}$ ) to power ground. An external voltage source higher than internal regulator output can be connected ( $\text{VEN/UVLO} > 0.4\text{ V}$ ) to increase MOSFET driving capability in terms of gate driver VTH overdriving or output current capability required at high switching frequency.
15		EP	Pin internally connected to exposed pad and electrically isolated. Connect to PGND plane.
16		NC	Not internally connected
17		BST	Bootstrap supply for the high-side gate driver. Connect an external diode between VCC and BOOT and capacitor (100 nF typ.) between BOOT and SW pins.
18		HO	High-side MOSFET gate drive output. Optional series resistor may be connected to adjust switching times for EMI compatibility.
19		SW	Switching node to be connected to the source of the HS MOSFET, drain of the LS MOSFET and bootstrap capacitor terminal.
20		VIN	Voltage input for the internal circuitry and VCC linear regulator.
E.P.		EP	Exposed Pad. Connect to PGND plane.

### 3 Typical application circuit

Figure 3. Typical application



**Table 2. Schematic application components description**

Symbol	Description
$C_{IN}$	Input capacitor
$C_{BST}$	Bootstrap capacitor
$C_{OUT}$	Output capacitor
$C_C$	Compensation capacitor
$C_P$	Compensation capacitor
$R_F$	Compensation resistor
$C_S$	Feedforward capacitor
$R_S$	Feedforward resistor
$R_U$	High-side feedback resistor
$R_D$	Low-side feedback resistor
$C_{SS}$	Soft-start capacitor
$R_{RT}$	Frequency adjust resistor
$R_{LIM}$	Current limit resistor
$L_F$	Buck inductor
$Q_1$	High-side MOSFET
$Q_2$	Low-side MOSFET
D	Bootstrap Diode

## 4 Maximum ratings

**Table 3. Absolute maximum ratings**

Symbol	Parameter	Min.	Max.	Unit
$V_{IN}$	Input voltage	-0.3	100	V
SW	Switching node	-1	100	V
	Switching node (20 ns transient)	-5	100	V
ILIM	Current limit pin	-1	100	V
EN/UVLO	Enable pin and undervoltage lockout	-0.3	100	V
VCC	VCC pin	-0.3	13	V
FB, COMP, SS/TRK, RT	Analog pins	-0.3	4.6	V
SYNCIN	Synchronization input	-0.3	8	V
BST	Bootstrap pin	-0.3	100	V
BST to SW	Bootstrap to SW voltage difference	-0.3	13	V
LO	20 ns transient	-3		V
PGOOD	Power Good	-0.3	14	V
$T_J$	Operating junction temperature	-40	150	°C
$T_{STG}$	Storage temperature range	-40	150	°C

**Note:** *Stressing the device above the absolute maximum rating may cause permanent damage to the device. These are stress ratings only and operation of the device at these or any other conditions above those indicated in the operating sections of this specification is not implied. Exposure to absolute maximum rating conditions may affect device reliability.*

**Table 4. Thermal data**

Symbol	Parameter	Value	Unit
$R_{thJA}$	Thermal resistance junction-ambient	30	°C/W

1. FR4 board with using 1 sq-in pad, 1 oz Cu.

**Table 5. ESD performance**

Symbol	Parameter	Test conditions	Value	Unit
ESD	ESD protection voltage	HBM	2	kV
		CDM	500	V

**Table 6. Recommended operating conditions**

Symbol	Parameter	Value	Unit
$V_{IN}$	Input voltage	6 to 75	V
EN/UVLO	Analog pins	0 to $V_{IN}$	V
PGOOD	Power Good	0 to 13	V
$I_{SYNCOUT}$	SYNCOUT pin sink and source currents	-1 to 1	mA
$I_{PGOOD}$	PGOOD sink current	2	mA
$T_{OP}$	Operating junction temperature range	- 40 to 125	°C

## 5 Electrical characteristics

$V_{EN/UVLO} = 1.5\text{ V}$ ,  $V_{IN} = 48\text{ V}$ ;  $R_{RT} = 24.9\text{ k}\Omega$ ; typical values are at  $T_J = 25\text{ }^\circ\text{C}$ ; minimum and maximum values are at  $-40\text{ }^\circ\text{C} \leq T_J \leq 125\text{ }^\circ\text{C}$ , unless otherwise specified.

**Table 7. Electrical characteristics**

Symbol	Parameter	Test conditions	Min.	Typ.	Max.	Unit
<b>Input Supply</b>						
$V_{IN}$	Operating input voltage		6		75	V
$I_Q$	Quiescent current	Not switching, $V_{SS/TRK} = 0\text{ V}$		1.8	2.3	mA
		$V_{EN/UVLO} = 1\text{ V}$		1.75	2.25	mA
$I_{Q-SDN}$	Shutdown input current	$V_{EN/UVLO} = 0\text{ V}$ , $V_{VCC} < 1\text{ V}$		8.5	21	$\mu\text{A}$
<b>VCC regulator</b>						
$V_{VCC}$	Internal regulator voltage	$V_{SS/TRK} = 0\text{ V}$ , $9\text{ V} \leq V_{IN} \leq 75\text{ V}$ , $I_{VCC} = 10\text{ mA}$	7.3	7.5	7.7	V
$V_{VCC-LDO}$	VIN to VCC dropout voltage	$V_{IN} = 6\text{ V}$ , $V_{SS/TRK} = 0\text{ V}$ , $I_{VCC} = 20\text{ mA}$ ; $T_J = 25\text{ }^\circ\text{C}$		0.25	0.63	V
$I_{SC-LDO}$	VCC short-circuit current	$V_{SS/TRK} = 0\text{ V}$ , $V_{VCC} = 0\text{ V}$ ; $T_J = 25\text{ }^\circ\text{C}$	40	50	70	mA
$V_{VCC-UV}$	VCC undervoltage threshold	$V_{VCC}$ rising	4.8	4.93	5.2	V
$V_{VCC-UVH}$	VCC undervoltage hysteresis	$V_{VCC}$ falling		0.26		V
$V_{VCC-EXT}^{(1)}$	Minimum external bias supply voltage	Voltage required to disable VCC regulator	8			V
$I_{VCC}$	External VCC input current, Not switching	$V_{SS/TRK} = 0$ , $V_{VCC} = 13\text{ V}$			2.5	mA
<b>Enable and Input UVLO</b>						
$V_{SDN}$	Shutdown to stand-by threshold	$V_{EN/UVLO}$ rising		0.42		V
$V_{SDN-HYS}$	Shutdown threshold hysteresis	EN/UVLO falling		50		mV
$V_{EN}$	Standby to operating threshold	$V_{EN/UVLO}$ rising	1.16	1.2	1.25	V
$I_{EN-HYS}$	Standby to operating hysteresis current	$V_{EN/UVLO} = 1.5\text{ V}$	8	10	11	$\mu\text{A}$
<b>Error Amplifier</b>						
$V_{REF}$	FB reference voltage	FB connected to COMP	792	800	808	mV
$I_{FB-BIAS}$	FB input bias current	$V_{FB} = 0.8\text{ V}$ ; $T_J = 25\text{ }^\circ\text{C}$	-0.1		0.1	$\mu\text{A}$
$V_{COMP-OH}$	COMP output high voltage	$V_{FB} = 0\text{ V}$ , COMP sourcing 1 mA		3.3		V
$V_{COMP-OL}$	COMP output low voltage	COMP sinking 1 mA; $T_J = 25\text{ }^\circ\text{C}$			0.3	V
$AVOL^{(1)}$	DC gain			94		dB
$GBW^{(1)}$	Unity gain bandwidth			6.5		MHz
<b>Soft-Start and Voltage Tracking</b>						
$I_{SS}$	SS/TRK capacitor charging current	$V_{SS/TRK} = 0\text{ V}$	7.5	10	12	$\mu\text{A}$
$R_{SS}$	SS/TRK discharge FET resistance	$V_{EN/UVLO} = 1\text{ V}$ , $V_{SS/TRK} = 0.1\text{ V}$		12		$\Omega$
$V_{SS-FB}$	SS/TRK to FB offset	$T_J = 25\text{ }^\circ\text{C}$	-15		15	mV
$V_{SS-CLAMP}$	SS/TRK clamp voltage	$V_{SS/TRK} - V_{FB}$ , $V_{FB} = 0.8\text{ V}$		115		mV



Symbol	Parameter	Test conditions	Min.	Typ.	Max.	Unit
<b>Power Good</b>						
PG <sub>UTH</sub>	FB upper threshold for PGOOD high to low	% of V <sub>REF</sub> , V <sub>FB</sub> rising	106	108	110	%
PG <sub>LTH</sub>	FB lower threshold for PGOOD high to low	% of V <sub>REF</sub> , V <sub>FB</sub> falling	90	92	94	%
PG <sub>HYS_U</sub>	PGOOD upper threshold hysteresis	% of V <sub>REF</sub>		3		%
PG <sub>HYS_L</sub>	PGOOD lower threshold hysteresis	% of V <sub>REF</sub>		2		%
T <sub>PG-RISE</sub> <sup>(1)</sup>	PGOOD rising filter	FB to PGOOD rising edge		10/F <sub>SW</sub>		μs
T <sub>PG-FALL</sub> <sup>(1)</sup>	PGOOD falling filter	FB to PGOOD falling edge		10/F <sub>SW</sub>		μs
V <sub>PG-OL</sub>	PGOOD low state output voltage	V <sub>FB</sub> = 0.9 V, I <sub>PGOOD</sub> = 2 mA			150	mV
I <sub>PG-OH</sub>	PGOOD high state leakage current	V <sub>FB</sub> = 0.8 V, V <sub>PGOOD</sub> = 13 V; T <sub>J</sub> = 25 °C			100	nA
<b>Oscillator</b>						
F <sub>SW</sub>	Oscillator frequency	R <sub>RT</sub> = 100 kΩ		115		kHz
		R <sub>RT</sub> = 25 kΩ	380	400	420	
		R <sub>RT</sub> = 11 kΩ		800		
<b>Synchronization input / output</b>						
F <sub>SYNC</sub>	SYNCIN external clock frequency (> 100 kHz < 1 MHz)	% of nominal frequency set by R <sub>RT</sub>	-20		+50	%
V <sub>SYNC-IH</sub>	Minimum SYNCIN input logic high		2			V
V <sub>SYNC-IL</sub>	Maximum SYNCIN input logic low				0.8	V
R <sub>SYNCIN</sub>	SYNCIN input resistance	V <sub>SYNCIN</sub> = 3 V		20		kΩ
T <sub>SYNCI-PW</sub>	SYNCIN input minimum pulse-width	Minimum high state or low state duration; T <sub>J</sub> = 25 °C	50			ns
V <sub>SYNCO-OH</sub>	SYNCOOUT high state output voltage	I <sub>SYNCOOUT</sub> = -1 mA (sourcing)	3			V
V <sub>SYNCO-OL</sub>	SYNCOOUT low state output voltage	I <sub>SYNCOOUT</sub> = 1 mA (sinking)			0.4	V
T <sub>SYNCOOUT</sub>	Delay from HO rising to SYNCOOUT leading edge	V <sub>SYNCIN</sub> = 0 V, T <sub>S</sub> = 1/F <sub>SW</sub> , F <sub>SW</sub> set by R <sub>RT</sub>		T <sub>S</sub> / 2-140		ns
T <sub>SYNCIN</sub>	Delay from SYNCIN leading edge to HO rising	50% to 50%, R <sub>T</sub> = 11 kΩ, V <sub>IN</sub> = 75 V		190		ns
<b>Bootstrap and BST UVLO</b>						
I <sub>Q-BST</sub>	BST to SW quiescent current, not switching	V <sub>SS/TRK</sub> = 0 V, V <sub>SW</sub> = 48 V, V <sub>BST</sub> = 54 V		300	500	μA
V <sub>BST-UV</sub>	BST to SW undervoltage detection	V <sub>BST</sub> - V <sub>SW</sub> falling		3.4		V
V <sub>BST-HYS</sub>	BST to SW undervoltage hysteresis	V <sub>BST</sub> - V <sub>SW</sub> rising		0.42		V
<b>PWM Control</b>						
T <sub>ON(MIN)</sub>	Minimum controllable on-time	V <sub>BST</sub> - V <sub>SW</sub> = 7 V, HO 50% to 50%		40	60	ns
T <sub>OFF(MIN)</sub>	Minimum off-time	V <sub>BST</sub> - V <sub>SW</sub> = 7 V, HO 50% to 50%		180	250	ns
DC <sub>MAX</sub>	Maximum duty cycle	F <sub>SW</sub> = 100 kHz, 6 V ≤ V <sub>VIN</sub> ≤ 60 V	98	99		%
		F <sub>SW</sub> = 400 kHz, 6 V ≤ V <sub>VIN</sub> ≤ 60 V	90	94		%
V <sub>RAMP(min)</sub>	Ramp valley voltage (COMP at 0% duty cycle)			300		mV
k <sub>FF</sub>	PWM feedforward gain (V <sub>IN</sub> / V <sub>RAMP</sub> )	6 V ≤ V <sub>VIN</sub> ≤ 75 V		30		V/V

Symbol	Parameter	Test conditions	Min.	Typ.	Max.	Unit
<b>PWM Control</b>						
$I_{RS}$	ILIM source current, $R_{SENSE}$	25 °C	90	100	110	$\mu A$
		-40 °C to 125 °C	80	100	110	
$I_{RDSON}$	$I_{LIM}$ source current, $R_{DS(on)}$ mode	SW voltage detected at $I_{LIM}$ , $T_J = 25$ °C	180	200	220	$\mu A$
$I_{RSTC}^{(1)}$	$I_{LIM}$ current temperature compensation	$R_{DS-ON}$ mode		4500		ppm/°C
		$R_{SENSE}$ mode		0		
$V_{ILIM-TH}$	ILIM comparator threshold at ILIM		-9	-2	4.5	mV
<b>Short-circuit protection (SCP)</b>						
$V_{CLAMP-OS}$	Clamp offset voltage – no current limiting	CLAMP to COMP steady-state offset voltage; -40 ≤ $T_J$ ≤ +125 °C		0.2 + $V_{VIN}/150$		V
$V_{CLAMP-MIN}$	Minimum clamp voltage	CLAMP voltage with continuous current limiting; -40 ≤ $T_J$ ≤ +125 °C		0.3 + $V_{VIN}/300$		V
<b>Short-circuit protection (SCP)</b>						
$C_{HICC-DEL}$	Hiccup mode activation delay	Clock cycles with current limiting before hiccup off-time activated		128		cycles
$C_{HICCUP}$	Hiccup mode off-time after activation	Clock cycles with no switching followed by SS/TRK release		8192		cycles
<b>Diode Emulation</b>						
$V_{ZCD-SS}$	Zero-cross detect (ZCD) soft-start ramp	ZCD threshold measured at SW pin 50 clock cycles after first HO pulse		0		mV
$V_{ZCD-DIS}$	Zero-cross detect disable threshold (CCM)	ZCD threshold measured at SW pin 1000 clock cycles after first HO pulse		200		mV
$V_{DEM-TH}$	Diode emulation zero-cross threshold	Measured at SW with $V_{SW}$ rising	-7	-2	4	mV
<b>Gate Drivers</b>						
$R_{HO-UP}$	HO high-state resistance, HO to BST	$V_{BST} - V_{SW} = 7$ V, $I_{HO} = -100$ mA		1.5		$\Omega$
$R_{HO-DOWN}$	$R_{HO-DOWN}$ HO low-state resistance, HO to SW	$V_{BST} - V_{SW} = 7$ V, $I_{HO} = 100$ mA		0.9		$\Omega$
$R_{LO-UP}$	LO high-state resistance, LO to VCC	$V_{BST} - V_{SW} = 7$ V, $I_{LO} = -100$ mA		1.5		$\Omega$
$R_{LO-DOWN}$	LO low-state resistance, LO to PGND	$V_{BST} - V_{SW} = 7$ V, $I_{LO} = 100$ mA		0.9		$\Omega$
$I_{HOH}^{(1)}, I_{LOH}^{(1)}$	HO, LO source current	$V_{BST} - V_{SW} = 7$ V, HO = SW, LO = AGND		2.3		A
$I_{HOL}^{(1)}, I_{LOL}^{(1)}$	HO, LO sink current	$V_{BST} - V_{SW} = 7$ V, HO = BST, LO = VCC		3.5		A
$T_{HO-TR}, T_{LO-TR}$	HO, LO rise times	$V_{BST} - V_{SW} = 7$ V, $C_{LOAD} = 1$ nF, 20% to 80%		7		ns
$T_{HO-TF}, T_{LO-TF}$	HO, LO fall times	$V_{BST} - V_{SW} = 7$ V, $C_{LOAD} = 1$ nF, 80% to 20%		4		ns
$T_{HO-DT}^{(1)}$	HO turn-on deadtime	$V_{BST} - V_{SW} = 7$ V, LO off to HO on, 50% to 50%		14		ns
$T_{LO-DT}^{(1)}$	LO turn-on deadtime	$V_{BST} - V_{SW} = 7$ V, HO off to LO on, 50% to 50%		14		ns
<b>Thermal protection</b>						
$T_{SD}$	Thermal shutdown threshold	$T_J$ rising		175		°C

Symbol	Parameter	Test conditions	Min.	Typ.	Max.	Unit
T <sub>SD-HYS</sub>	Thermal shutdown hysteresis			20		°C

1. Specified by design – not tested in production.

Note: All minimum and maximum limits are specified by correlating the electrical characteristics to process and temperature variations and applying statistical process control.

## 6 Functional description

The L3751 device is a native buck controller based on constant frequency voltage mode architecture.

The output voltage  $V_{OUT}$ , sensed by the feedback pin (FB), is compared to an internal reference (0.8 V) providing an error signal on the COMP pin. The comparison between the COMP voltage level and the internal programmable frequency sawtooth ramp, controls the activation time of the external power switches.

The main internal blocks are shown in the block diagram in Figure 1 and can be summarized as follows:

- The voltage regulator to supply the internal circuitry and provide a fixed internal reference. This block also implements a voltage monitor circuitry (UVLO) that checks the input and internal voltages
- The embedded external N-channel MOSFET drivers and the bootstrap capacitor circuitry to supply the high-side driver
- The embedded circuitry that generates the sawtooth ramp to modulate the duty cycle based on the internal programmable oscillator or the input synchronization signal. The input voltage feedforward is implemented for improved line transient response
- The voltage mode error amplifier
- The PWM comparators and the relative analog and digital circuitry necessary to drive the internal MOSFET drivers
- The soft-start circuitry to limit inrush current during the start-up phase and the reference clamper
- The adjustable senseless or precise valley current limit sensing block and hiccup circuitry to handle overload and short-circuit conditions
- The thermal shutdown circuitry to prevent thermal runaway
- The output voltage monitor circuitry which releases the PGOOD signal if the sensed output voltage is above 87% of the target value.

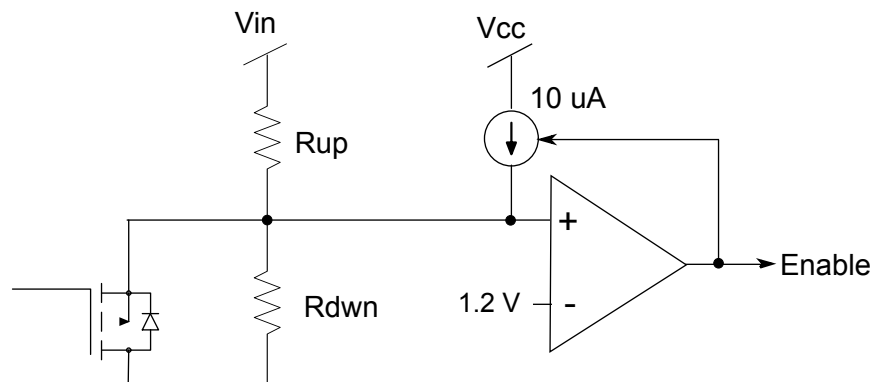
### 6.1 Precision enable

The EN/UVLO pin multiplexes the inherent functions as described below:

- $V_{EN} / UVLO < 0.4$  typ.: the device is in shutdown mode
- $0.4$  V typ.  $< V_{EN} / UVLO < 1.2$  V typ.: device in standby having the VCC regulator active but the device operation inhibited and SS / TRK pin in low impedance
- $V_{EN} / UVLO > 1.2$  V typ.: SS / TRK pin released and the device starts operating. An internal 10  $\mu$ A current flows to the external resistor divider to design the enable to UVLO hysteresis.

The central tap of a resistor divider connected to the EN/UVLO pin from  $V_{IN}$  designs the enable and undervoltage lockout thresholds referred to the input voltage as shown in the figure below.

Figure 4. EN / UVLO resistor divider



The value of the resistors composing the divider can be calculated as follows:

$$R_{UP} = \frac{V_{IN_{ON}} - V_{IN_{OFF}}}{10\mu A} \qquad R_{DWN} = R_{UP} \cdot \frac{1.2}{V_{IN_{ON}} - 1.2} \qquad (1)$$

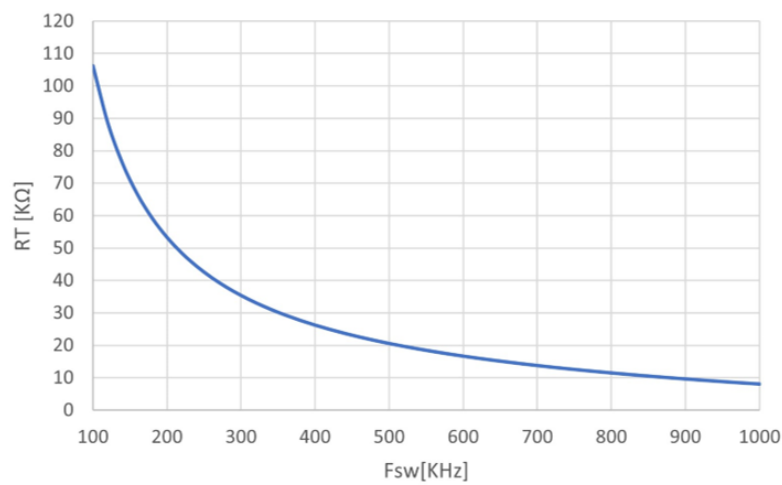
Where  $V_{IN_{ON}}$  and  $V_{IN_{OFF}}$  represent the desired turn-on and turn-off thresholds.

## 6.2 Oscillator and synchronization

The programmable internal oscillator frequency depends on the external resistor connected between the RRT pin and ground according to the following formula:

$$R_{RT}[K\Omega] = \frac{10500}{f_{SW}[KH]} + 0.004 \times (400 - F_{SW}[KHz]) \qquad (2)$$

**Figure 5.  $R_{RT}$  resistor value for  $f_{SW}$  programming**



The switching frequency can be alternatively adjusted, synchronizing the device to the external clock signal fed to the SYNCIN pin that satisfies the following requirements:

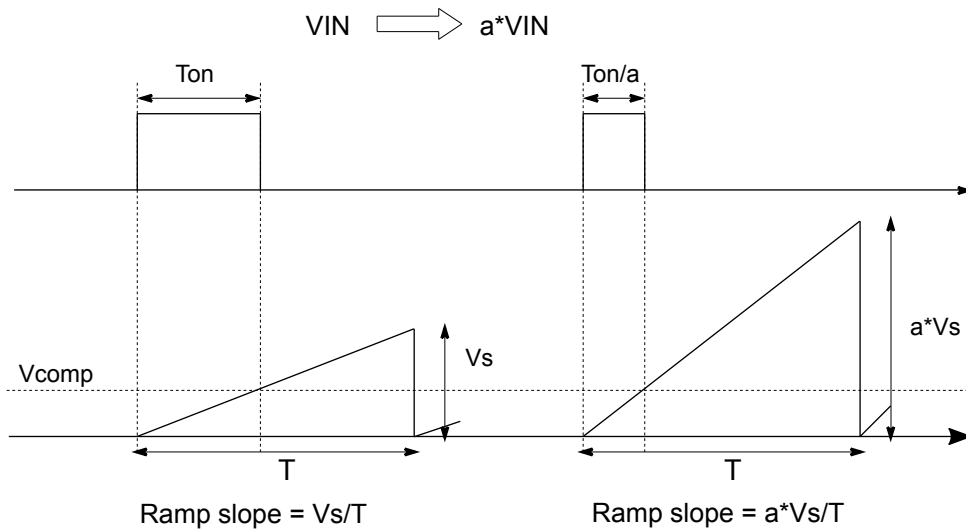
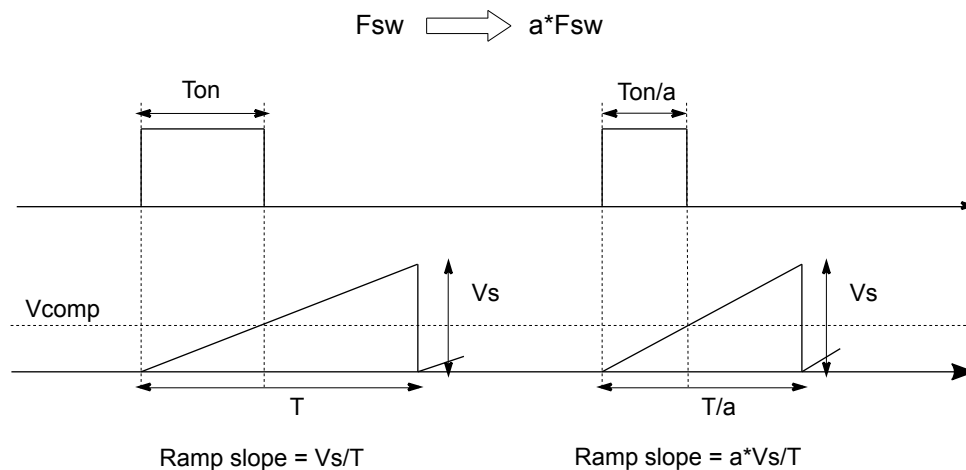
- Clock frequency range: 100 kHz to 1 MHz
- Clock frequency: -20% to +50% of the oscillator frequency programmed by  $R_{RT}$
- Clock maximum amplitude: 13 V
- Clock minimum pulse: 50 nsec

The device works in phase with the synchronization signal.

The L3751 features the internal sawtooth ramp feedforward for constant PWM gain over input voltage and programmable switching frequency range:

$$G_{PWM} = \frac{V_{OUT}}{V_{COMP}} = \frac{V_{IN}}{\Delta V_{RAMP}} = \frac{V_{IN}}{K \cdot V_{IN}} = \frac{1}{K} \qquad (3)$$

Where  $K = 30$ .

**Figure 6. Internal sawtooth ramp feedforward - voltage feed forward**

**Figure 7. Internal sawtooth ramp feedforward - Fsw adjusted by external resistor**


The device generates a synchronization signal available at the SYNCOUT pin that has 180° phase shift referred to the rising edge of the internal oscillator. Synchronized operation is easily accomplished connecting the SYNCOUT of the master to the SINCIN of the slave device to reduce the RMS current of the input filter and increase the EMI performance.

### 6.3 Soft-start

The soft-start (SS) feature minimizes the inrush current surge, decreases the stress of the power components during the power-up phase and makes the output voltage increase monotonically.

The device is inhibited as long as the EN/UVLO pin voltage is lower than the 0.4 V typ.

As soon as the EN/UVLO pin voltage exceeds the 1.2 V typ. rising threshold the soft-start phase takes place; an internal 10 μA typ. current source charges the external soft-start capacitor to ramp the SS/TRK pin voltage, clamping the internal error amplifier reference voltage. When the SS/TRK voltage exceeds the 0.8 V threshold the internal EA reference drives the non-inverting input so the SS is ended.

Figure 8. Soft-start block diagram

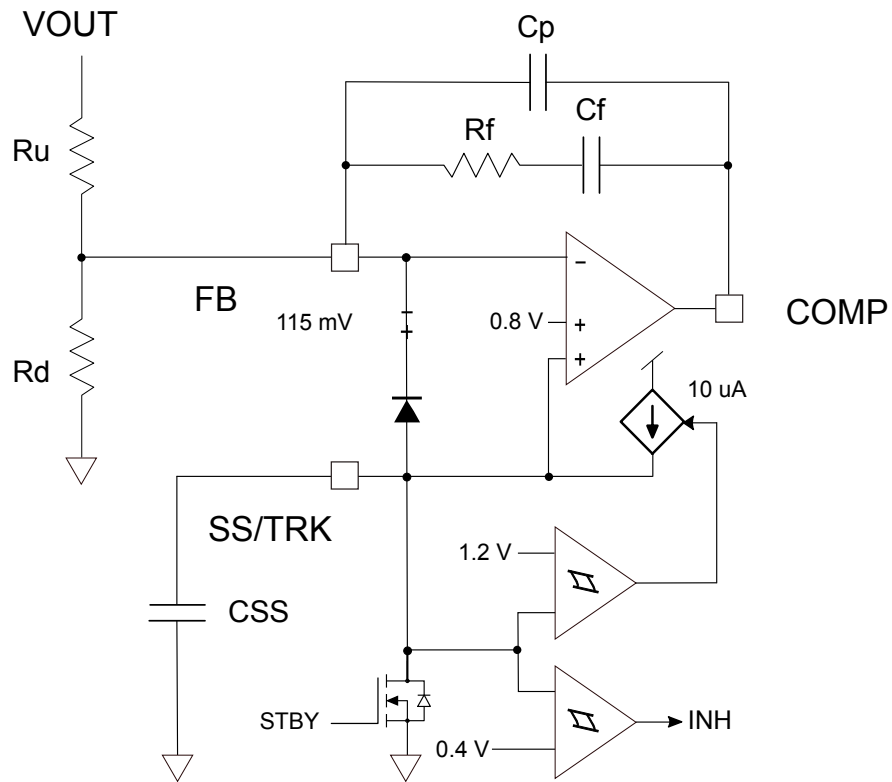
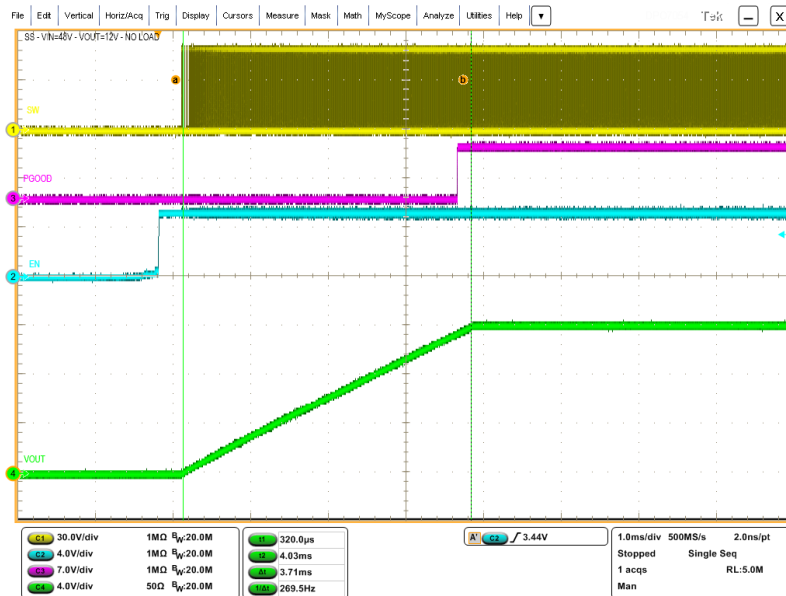


Figure 9. Soft-start phase



In the same way the device is able to track an external voltage source driving the SS/TRK pin in excess of the internal 10 µA typ current capability, like a simple voltage divider, to implement radiometric startup for multiple power rails suitable for digital ICs.

Figure 10. Schematic to implement input voltage tracking

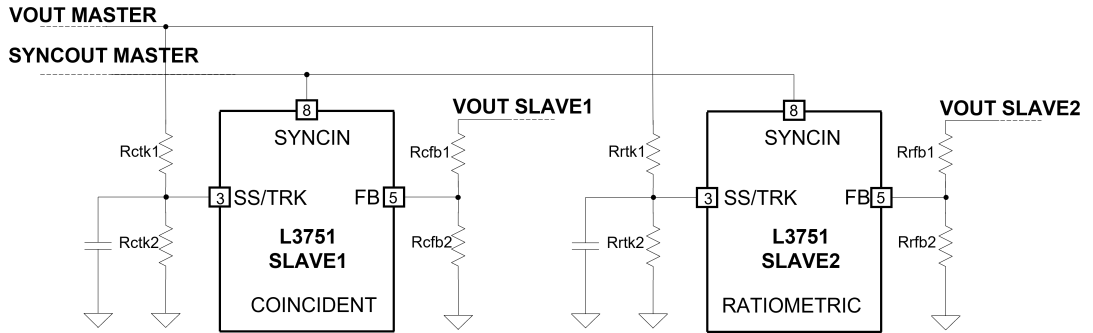
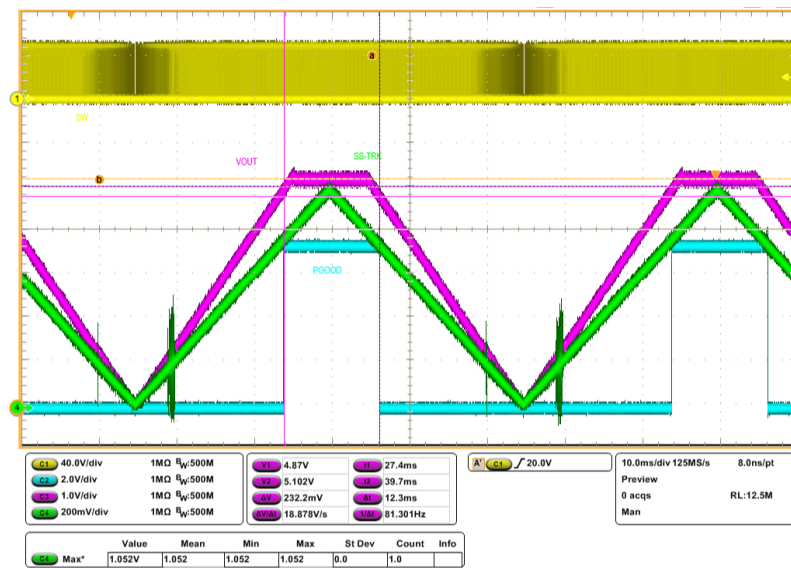


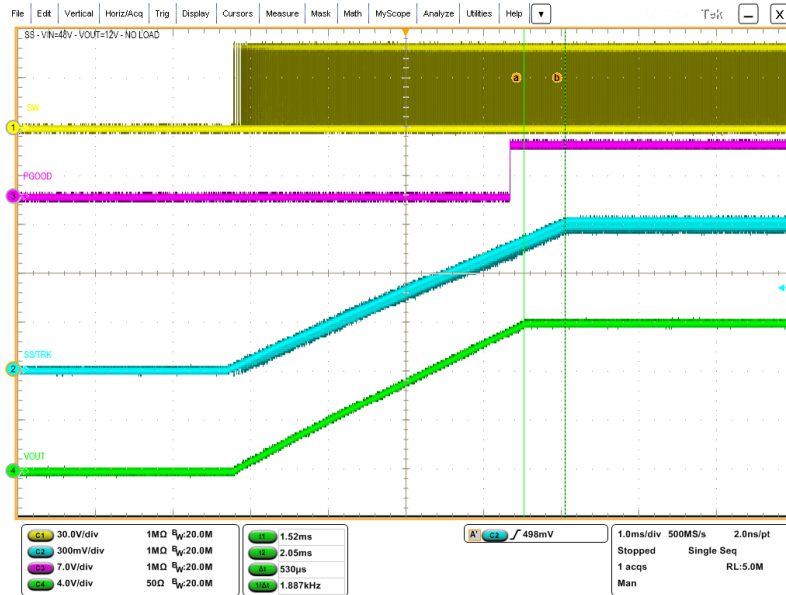
Figure 11. Input voltage tracking



After startup, the SS/TRK voltage is dynamically clamped 115 mV above the FB pin voltage in order to implement a partial soft-start, depending on the actual FB voltage, to recover from an abrupt load removal in overcurrent event.



**Figure 12. SS/TRK clampler operation**



## 6.4 Error amplifier

The error amplifier (EA) provides the error signal to be compared with the sawtooth to perform the pulse width modulation. Its non-inverting input is internally connected to a 0.8 V voltage reference, while its inverting input (FB) and output (COMP) are externally available for feedback and frequency compensation. In this device, the error amplifier is a voltage mode operational amplifier so with high DC gain and low output impedance.

The uncompensated error amplifier characteristics are the following:

**Table 8. Error amplifier characteristic**

Characteristic	Value
Non-inverting input voltage reference voltage	800 mV
Low frequency gain (A0)	95 dB
GBWP	6.5 MHz
Output voltage swing	0.3 to 3.3 V
Source / sink current capability	20 / 45 mA

In continuous conduction working mode (CCM), the transfer function of the power section has two poles due to the LC filter and one zero due to the ESR of the output capacitor. Different topologies of compensation networks can be used depending on the ESR value of the output capacitor.

If the zero introduced by the output capacitor helps to compensate the double pole of the LC filter, a type II compensation network can be used. Otherwise, a type III compensation network must be used (see Section xx Compensation network for details on the compensation network design).

Anyway, the methodology to compensate the loop is to introduce zeros to obtain a safe phase margin.

## 6.5 Embedded gate driver supply

The embedded gate driver power supply is the 7.5 V typ. LDO regulator output available on the VCC pin for the external compensation. Connect an mlcc capacitor value between 470 nF and 2.2  $\mu$ F for proper operation.

The typical regulator dropout voltage is 250 mV @  $V_{IN} = 6$  V,  $I_{VCC} = 20$  mA so the VCC voltage may drop at input voltage lower than 7.75 V. Be aware that the VCC drop at low input voltage may increase “not logic level MOSFET”  $R_{DS(ON)}$ , affecting nominal programmed OCP threshold and increasing switching / conduction losses. For operation compatible with low input voltage, select “logic level MOSFET” with guaranteed maximum  $V_{TH} = 4.5$  V.

The VCC regulator provides the gate current for direct low-side and floating high-side driving, through the bootstrap capacitor charge refresh. Make sure to select external MOSFETs in order that the total driving current consumption is smaller than VCC regulator minimum output current capability at the programmed switching frequency:

$$I_{DRV} = (Q_{GHS} + Q_{GLS}) \cdot f_{sw} \leq I_{VCC\ MIN} = 40mA \quad (4)$$

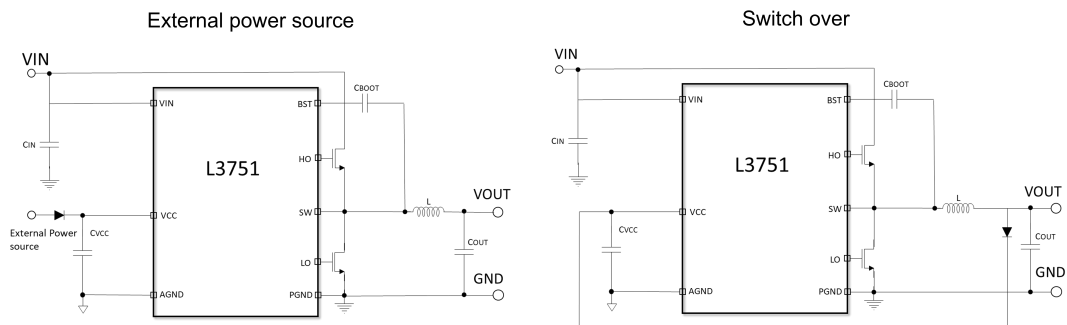
The internal LDO is turned off if an external voltage source drives the VCC higher than regulated LDO.

This function is useful to decrease the power dissipation of internal LDO and increase light load efficiency of the conversion. A higher VCC voltage also means a higher driving voltage for better  $R_{dson}$  and efficiency gain at high load.

Typically, the VCC can be upgrade by connecting, with an external diode, to an External Power Supply or directly to Vout if it is between 8 V and 13 V.

The external power supply at VCC pin must be provided/removed when Vin is present on L3751 pin.

**Figure 13. VCC power circuit**

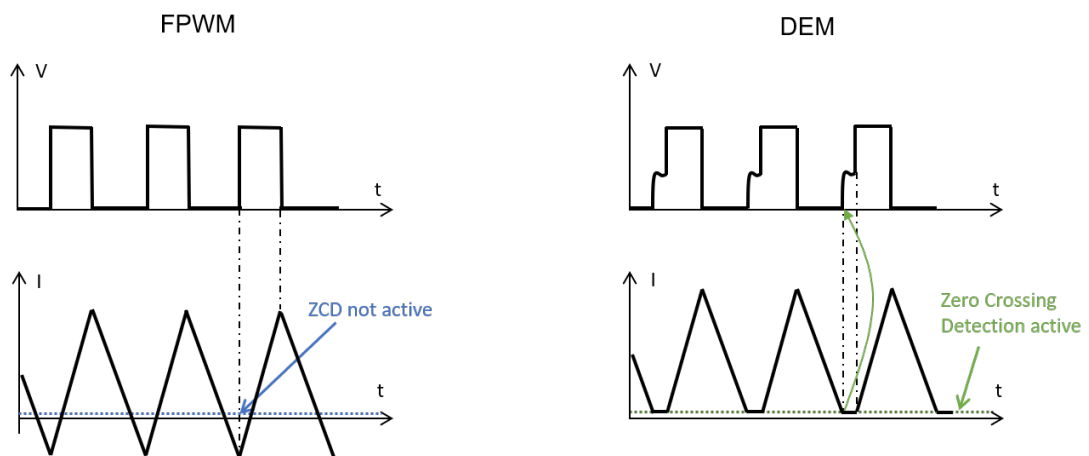


## 6.6 Light load operation

The device always implements diode emulation, so-called “DEM”, during soft-start to support pre-charged output capacitor at device startup.

The state of the SYNCIN pin at power-up determines the light load operation: low logic level selects DEM, high logic level or detected synchronization clock signal enables the forced PWM mode, so-called “FPWM”. In detail, the DEM to FPWM transition is implemented smoothly ramping the zero current detecting threshold (ZCD) from 0 V to 200 mV in 1000 clock cycles starting from the first PWM pulse from the loop.

**Figure 14. DEM vs. FPWM management in light load condition**



The DEM mode operates in DCM and pulse skipping at light load, maximizing the efficiency in these application conditions minimizing the conversion losses with controlled output voltage ripple.

The forced PWM (FPWM) over the load range makes the switching frequency constant and minimizes the output voltage ripple, suggested for low noise application like sensors or analog circuitry supply.

Figure 15. DEM to FPWM smooth transition in 1000 clk at powerup

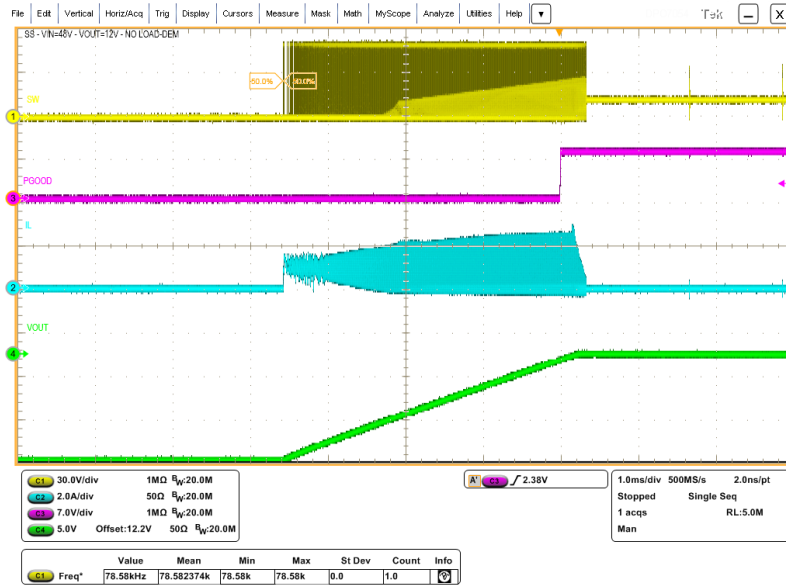


Figure 16. Efficiency typ. @ 240 KHz, V<sub>OUT</sub> = 5 V

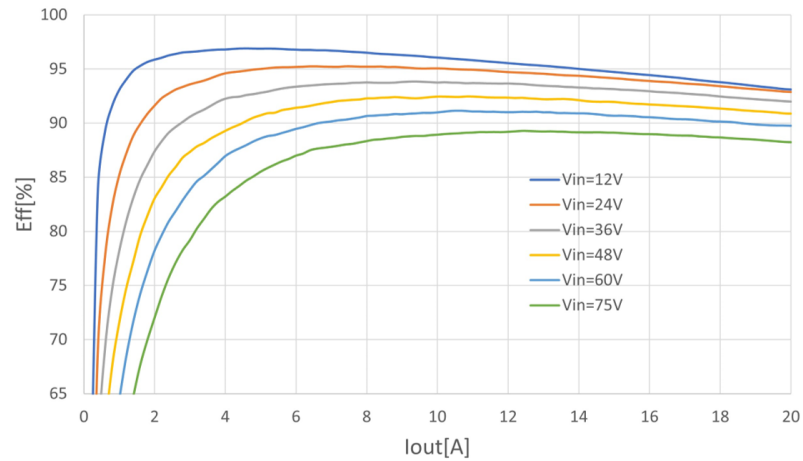


Figure 17. Efficiency typ. @ 240 KHz, V<sub>OUT</sub> = 12 V

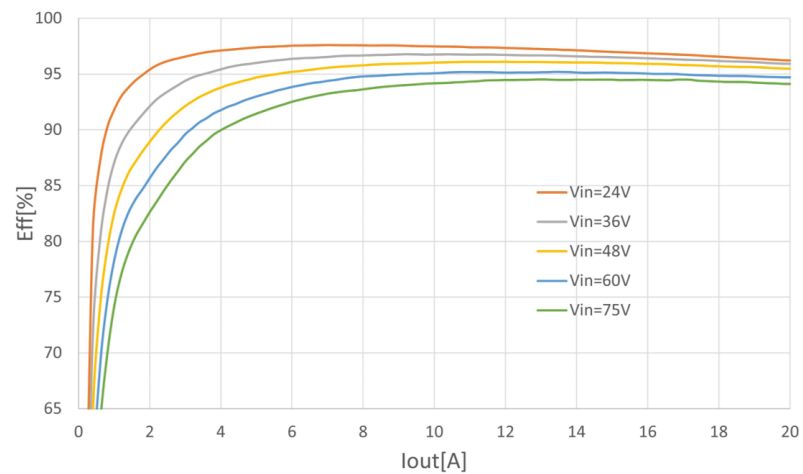


Figure 18. Efficiency typ. @ 240 KHz DEM vs. FPWM

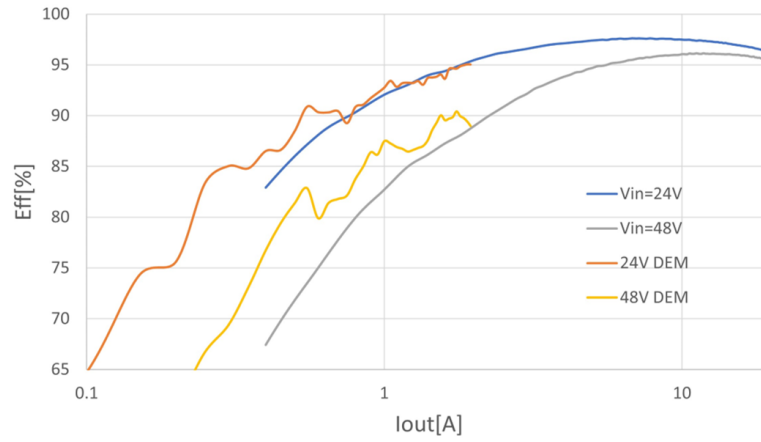


Figure 19. DEM output voltage ripple at zero load

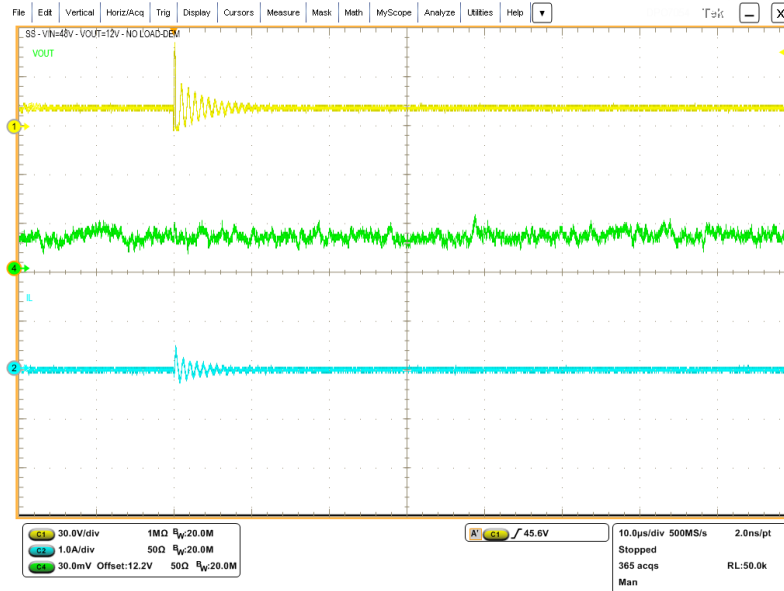
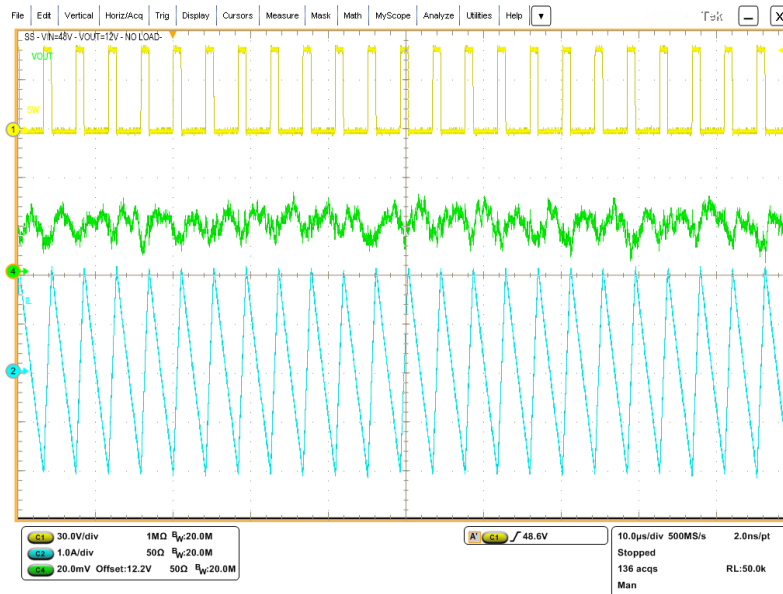


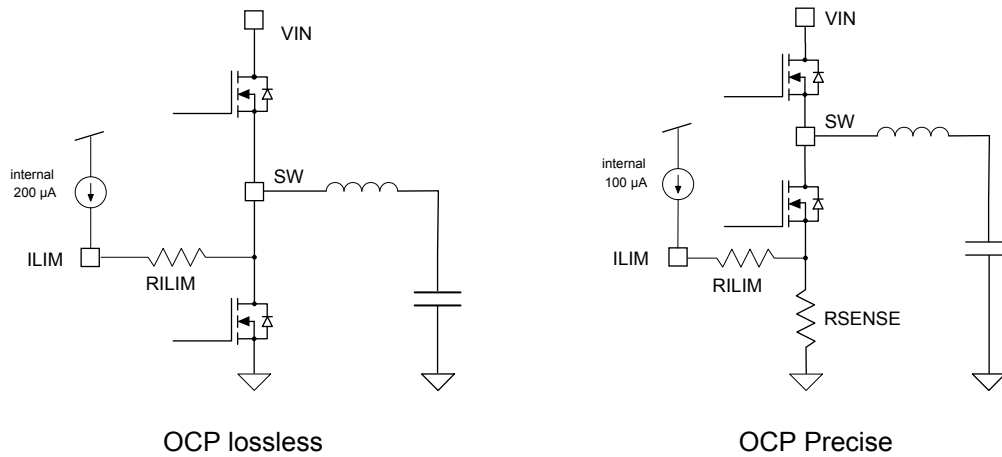
Figure 20. FPWM output voltage ripple at zero load



## 6.7 Overcurrent protection

The current protection circuitry features a constant current protection to handle an exceptional dynamic load request that can persist continuously for maximum 128 clock cycles. Within this time window, the device limits the DC output current accordingly with valley current threshold programmed value with  $R_{ILIM}$  resistor, as shown in the figure below.

Figure 21.  $R_{ILIM}$  resistor connection to define lossless and precise OCP setting



In case the overcurrent event is detected longer, the hiccup protection is triggered to limit the stress of the external power components in case of continuous short-circuit event: the switching activity is prevented for 8192 clock cycles and the SS capacitor is discharged for a new soft-start cycle.

Figure 22. Constant current in persistent short-circuit

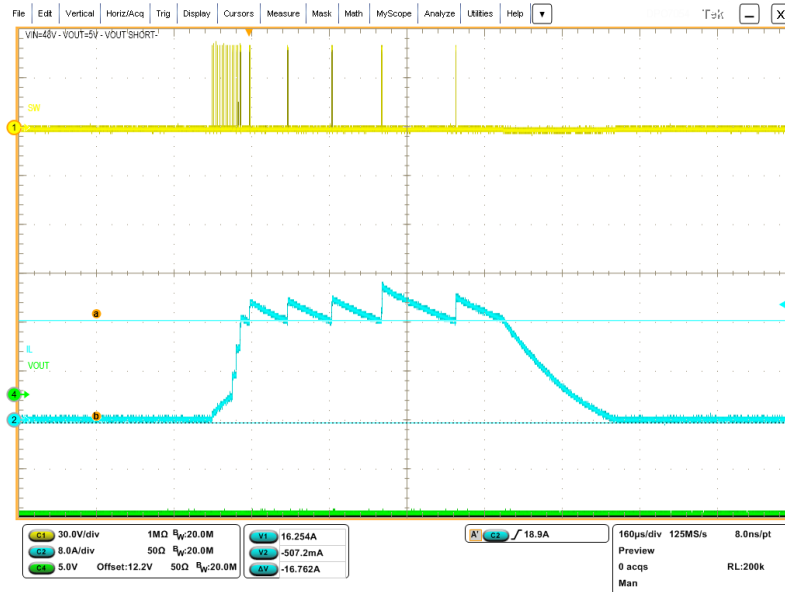
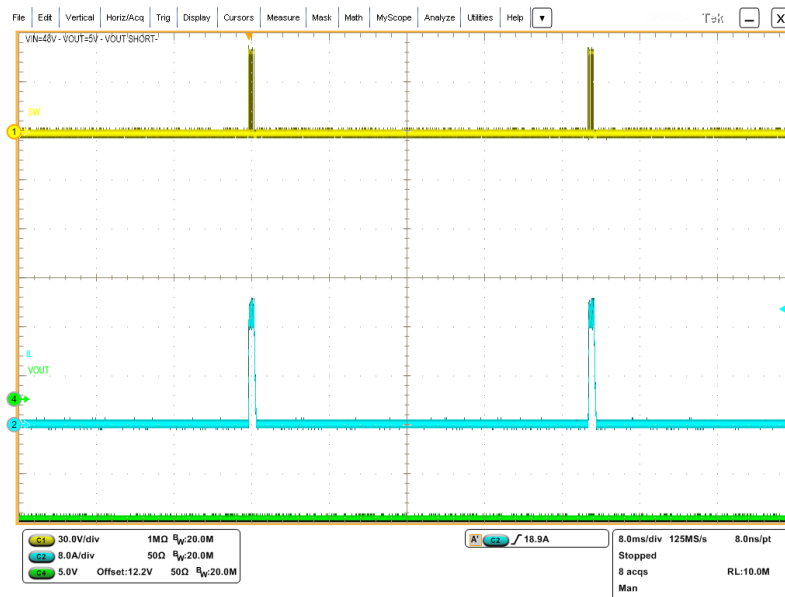


Figure 23. Hiccup in persistent short-circuit



The L3751 implements an improved pulse-by-pulse valley current sensing thanks to dedicated control logic for an effective current protection over the duty cycle range. The device supports programmable valley current monitoring across an optional sensing resistor for the best reading accuracy or across the on-state  $R_{SDON}$  of the low-side MOSFET to minimize the conduction losses, as shown in Figure 17.

The valley current threshold is easily programmed with series  $R_{ILIM}$  resistor connected from  $I_{LIM}$  pin to the selected sensing element (see Figure 17). As soon as the LO gate signal is driven high an internal generator source a constant current out of the  $I_{LIM}$  pin so the pin voltage is:

$$V_{ILIM}(t) = (R_{ILIM} + R_x) \cdot I_{ILIM} - R_x \cdot I_{VY}(t) \approx R_{ILIM} \cdot I_{ILIM} - R_x \cdot I_{VY}(t) \quad (5)$$

where  $R_x$  can be the low-side  $R_{SDON}$  or the shunt resistor. An internal comparator monitors the pin voltage and keeps the low LO signal high until it drops to  $V_{ILIM\_TH}$  threshold (-2 mV typ.)

$$I_{ILIM} = \begin{cases} 200\mu A & \text{at } T_J = 27^\circ C \text{ in case of } R_{DS(on)} \text{ lossless sensing} \\ 100\mu A & \text{at } T_J = 27^\circ C \text{ in case of precise sensing on shunt resistor} \end{cases} \quad (6)$$

Both levels compensated with the 4500 ppm/°C thermal coefficient.

As a consequence, assuming  $V_{ILIM} \approx 0$ , the  $R_{ILIM}$  value can be calculated as:

$$R_{ILIM} \approx \frac{R_x \cdot I_{VY\_MAX}}{I_{ILIM}} = \frac{R_x}{I_{ILIM}} \cdot \left( I_{O\_MAX} - \frac{\Delta I_L}{2} \right) \quad (7)$$

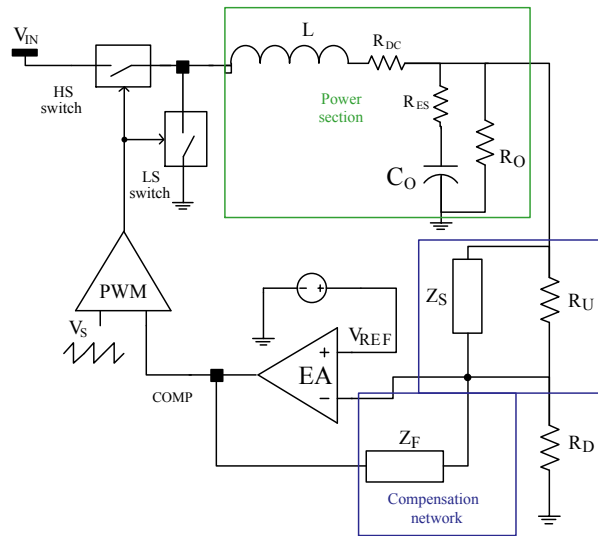
where the sensed inductor current  $I_{VY\_MAX}$  can be expressed in terms of  $I_{O\_MAX}$  DC output current and the inductor current ripple  $\Delta I_L$  for simplicity.

## 7 Closing the loop

### 7.1 Total transfer function

The compensation network assures stability and good dynamic performance over the application conditions. The loop of the L3751 is based on the voltage mode control. The embedded wide bandwidth operational amplifier can be considered ideal in the calculation of the compensator since its frequency response is much larger than designed system bandwidth.

**Figure 24. Voltage mode control loop**



The transfer function of the PWM modulator, from the error amplifier output (COMP pin) to the LX pin results in an almost constant gain, due to the voltage feedforward which generates a sawtooth with amplitude  $V_S$  directly proportional to the input voltage.

$$G_{PWM0} = \frac{V_{IN}}{V_S} = \frac{1}{K_{FF}} = 15 \quad (8)$$

The transfer function of the power section (i.e. the L-C filters and the output load) is:

$$G_{LC}(s) = \frac{R_O \parallel (R_O + 1/s \cdot C_O)}{R_O \parallel (R_O + 1/s \cdot C_O) + s \cdot C_O + R_{DC}} \quad (9)$$

given  $L$ ,  $R_{DC}$ ,  $C_O$ ,  $R_{ES}$  and  $R_O$  as defined in Figure 10.

For convenience, the  $G_{LC}$  can be written as:

$$G_{LC}(s) = G_{LC0} \cdot \frac{1 + \frac{s}{2\pi \cdot f_{ZESR}}}{1 + \frac{s}{2\pi \cdot Q \cdot f_{LC}} + \left(\frac{s}{2\pi \cdot f_{LC}}\right)^2} \quad \text{where } G_{LC0} = \frac{R_O}{R_O + R_{DC}} \approx 1 \quad (10)$$

$$f_{ZESR} = \frac{1}{2\pi \cdot C_O \cdot R_{ES}} \quad f_{LC} = \frac{1}{2\pi \cdot \sqrt{L \cdot C_O} \cdot \sqrt{\frac{R_O + R_{ES}}{R_O + R_{DC}}}} \approx \frac{1}{2\pi \cdot \sqrt{L \cdot C_O}} \quad (11)$$

$$Q = \frac{\sqrt{L \cdot C_O} \cdot \sqrt{R_O + R_{DC}} \sqrt{R_O + R_{ES}}}{L + C_O \cdot (R_O \cdot R_{DC} + R_O \cdot R_{ES} + R_{ES} \cdot R_{DC})} \approx \frac{\sqrt{L \cdot C_O} \cdot R_O}{L} = \sqrt{\frac{C_O}{L}} \cdot R_O \quad (12)$$

assuming the inductor and output capacitor parasitic resistance,  $R_{DC}$  and  $R_{ES}$ , negligible compared to  $R_O$ .



The total closed loop gain is:

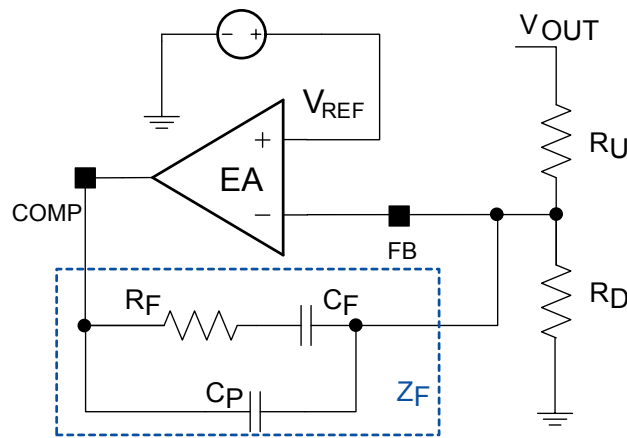
$$G_{LOOP}(s) = G_{PWM0} \cdot G_{LC}(s) \cdot G_{COMP}(s) \quad (13)$$

The implemented compensation networks represented with  $G_{COMP}(s)$  terms depend on the characteristics of the selected output capacitor, as explained in the following chapters.

## 7.2 Type II compensation network

If the equivalent series resistance (RES) of the output capacitor introduces a zero with a frequency inside the desired bandwidth (that is:  $2\pi \cdot R_{ES} \cdot C_O > 1 / BW$ ), this zero helps stabilize the loop. Electrolytic capacitors show non-negligible ESR ( $> 30 \text{ m}\Omega$  typically), so with this kind of output capacitor the type II network combined with the zero of the ESR allows the loop to be stabilized.

**Figure 25. Type II compensation network**



The type II compensation network transfer function, from  $V_{OUT}$  to COMP, is computed in the equation below:

$$G_{COMP II}(s) = -\frac{Z_F(s)}{R_U} = -1 \cdot \frac{1 + \frac{s}{2\pi \cdot f_{Z1}}}{\frac{s}{2\pi \cdot f_{P0}} \cdot \left(1 + \frac{s}{2\pi \cdot f_{P1HF}}\right)} \quad (14)$$

$$f_{Z1} = \frac{1}{2\pi \cdot R_F \cdot C_F} \quad f_{P0} = \frac{1}{2\pi \cdot (C_F + C_P) \cdot R_U} \quad f_{P1HF} = \frac{1}{2\pi \cdot R_F \cdot C_F \parallel C_P} \quad (15)$$

The following suggestions can be followed for a quite common compensation strategy, assuming that  $C_P \ll C_F$ .

$G_{LOOP}(s)$  in case of type II compensation network and electrolytic output capacitors can be written as follows at the at  $s = 2\pi \cdot f_{BW}$  to derive the  $R_F / R_U$  ratio as fixed:

$$G_{LOOP II}(s = 2\pi \cdot f_{BW}) \cong \frac{1}{K_{FF}} \cdot \frac{f_{LC}^2}{f_{ZESR}} \cdot \frac{R_F}{R_U} \cdot \frac{1}{f_{BW}} = 1 \quad (16)$$

After choosing the regulator bandwidth (typically  $f_{BW} < 0.2 \cdot f_{SW}$ ) and a value for  $R_U$ , usually between 1 k $\Omega$  and 50 k $\Omega$  in order to achieve  $C_F$  and  $C_P$  not comparable with parasitic capacitance of the board, the  $R_F$  required value is calculated as follows from the previous equation:

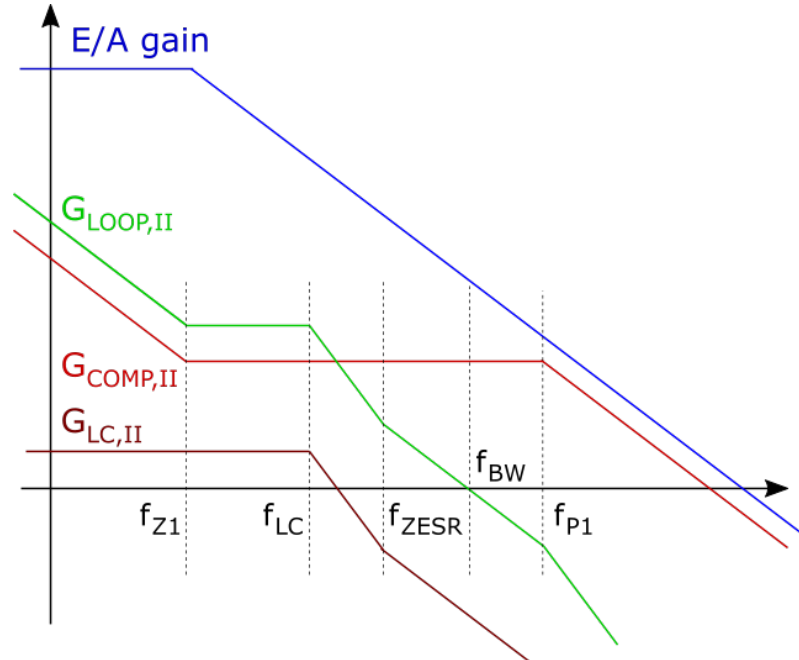
$$R_F = \frac{K_{FF} \cdot f_{ZESR} \cdot f_{BW}}{f_{LC}^2} \cdot R_U \quad (17)$$

Select  $C_F$  in order to place  $f_{Z1}$  below  $f_{LC}$  (typically  $0.1 \cdot f_{LC}$ ) and  $C_P$  to place  $f_{P1HF}$  at  $0.5 \cdot f_{SW}$

$$C_F = \frac{1}{2\pi \cdot R_F \cdot 0.1 \cdot f_{LC}} \quad C_P = \frac{1}{2\pi \cdot R_F \cdot 0.5 \cdot f_{SW}} \quad (18)$$

The resultant control loop and other transfer function gains are shown in the figure below. Type II compensation – Bode plot.

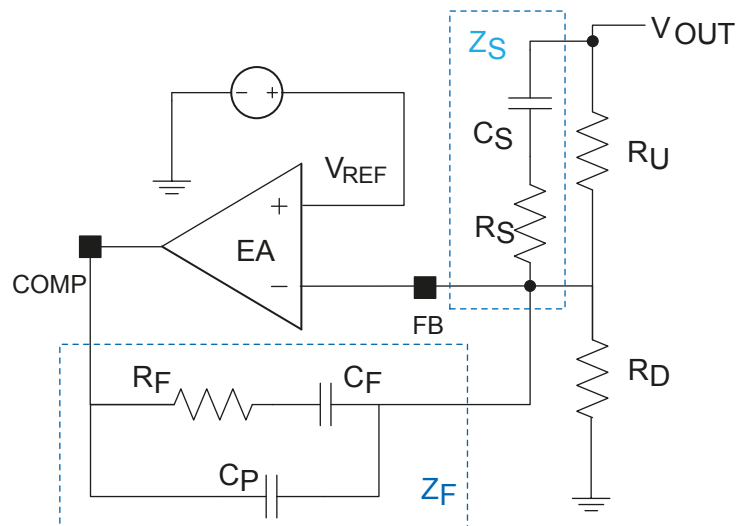
**Figure 26. Type II compensation - Bode plot**



### 7.3 Type III compensation network

If  $f_{ZESR}$  is higher than the target loop bandwidth, as usually happens if the output filter is based on MLCC ceramic capacitors, a type III compensation network must be designed.

**Figure 27. Type III compensation network**



The type III compensation network transfer function, from  $V_{OUT}$  to COMP, is computed in the equation below:

$$G_{COMPIII}(s) = -\frac{Z_F(s)}{R_U \parallel Z_F(s)} = -1 \quad (19)$$

$$\cdot \frac{\left(1 + \frac{s}{2\pi \cdot f_{Z1}}\right) \cdot \left(1 + \frac{s}{2\pi \cdot f_{Z2}}\right)}{\frac{s}{2\pi \cdot f_{P0}} \cdot \left(1 + \frac{s}{2\pi \cdot f_{P1HF}}\right) \cdot \left(1 + \frac{s}{2\pi \cdot f_{P2HF}}\right)}$$

In addition to the singularities of  $G_{COMPIII}(s)$ , shown in the previous section, one more zero and HF pole are present:

$$f_{Z2} = \frac{1}{2\pi \cdot (R_U + R_S) \cdot C_S} \quad f_{P2HF} = \frac{1}{2\pi \cdot R_S \cdot C_S} \quad (20)$$

The following suggestions can be followed for a quite common compensation strategy, assuming that  $C_P \ll C_F$  and  $R_S \ll R_U$ .

$G_{LOOP}(s)$  in case of type III compensation network and electrolytic output capacitors can be written as follows at the at  $s = 2\pi \cdot f_{BW}$  to derive the  $R_F / R_U$  ratio as fixed:

$$G_{LOOPIII}(s = 2\pi \cdot f_{BW}) \cong \frac{1}{K_{FF}} \cdot \frac{f_{LC}}{f_{BW}} \cdot \frac{R_F}{R_U} = 1 \quad (21)$$

After choosing the regulator bandwidth (typically  $f_{BW} < 0.2 \cdot f_{SW}$ ) and a value for  $R_U$ , usually between 1 kΩ and 50 kΩ in order to achieve  $C_F$  and  $C_P$  not comparable with parasitic capacitance of the board, the  $R_F$  required value is calculated as follows from the previous equation:

$$R_F = \frac{K_{FF} \cdot f_{BW}}{f_{LC}} \cdot R_U \quad (22)$$

Select  $C_F$  in order to place  $f_{Z1}$  below  $f_{LC}$  (typically  $0.1 \cdot f_{LC}$ ) and  $C_P$  to place  $f_{P1HF}$  at  $0.5 \cdot f_{SW}$ .

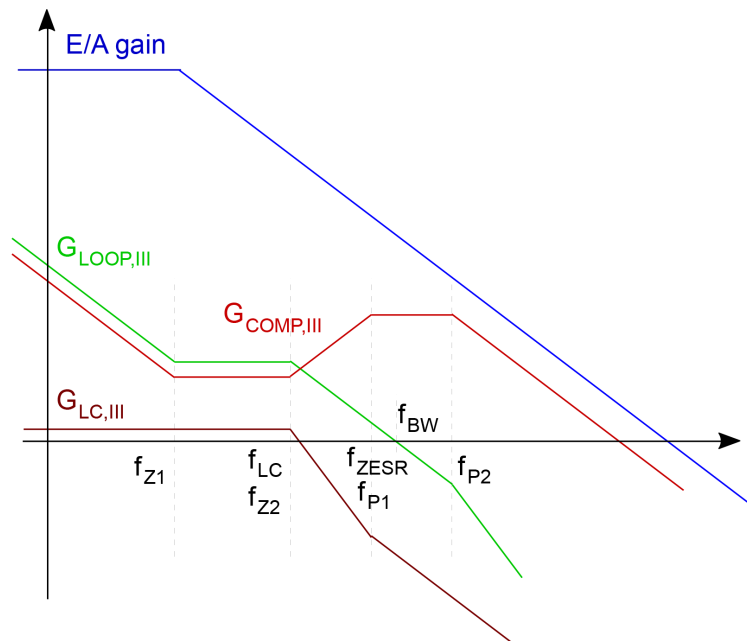
$$C_F = \frac{1}{2\pi \cdot R_F \cdot 0.1 \cdot f_{LC}} \quad C_P = \frac{1}{2\pi \cdot R_F \cdot 0.5 \cdot f_{SW}} \quad (23)$$

Select  $C_S$  in order to place  $f_{Z2}$  at  $f_{LC}$  and  $R_S$  to place  $f_{P2HF}$  at  $0.5 \cdot f_{SW}$ .

$$C_S = \frac{1}{2\pi \cdot R_U \cdot f_{LC}} \quad R_S = \frac{1}{2\pi \cdot C_S \cdot 0.5 \cdot f_{SW}} \quad (24)$$

The resultant control loop and other transfer function gains are shown in Figure 22. Type III compensation - Bode Plot

Figure 28. Type III compensation - Bode plot



## 8 Application notes

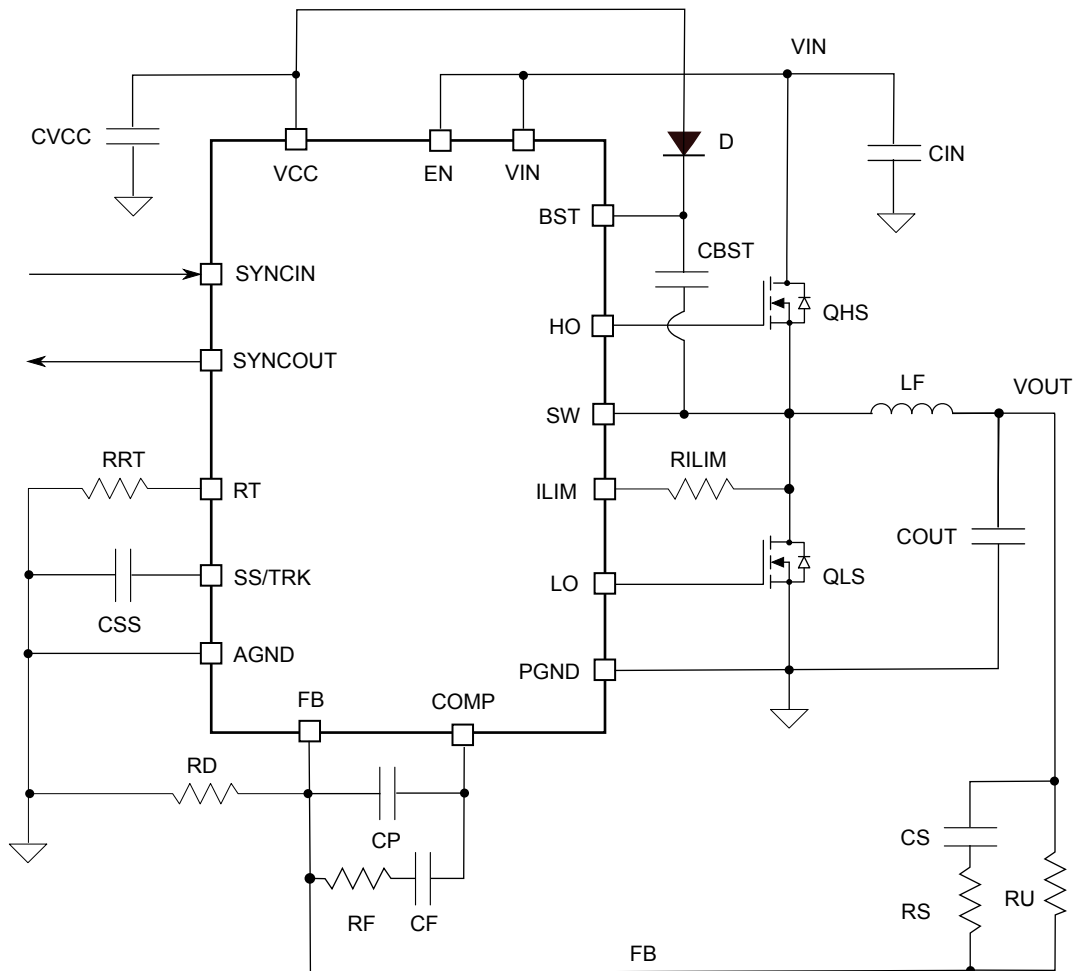
### 8.1 Output voltage divider

The error amplifier reference voltage is 0.85 V typical.

Referring to Figure 24 for Type II compensator and Figure 26 for type III, the output voltage is adjusted as follows:

$$V_{OUT} = 0.8 \cdot \left(1 + \frac{R_U}{R_D}\right) \quad (25)$$

Figure 29. L3751 application schematic



### 8.2 Synchronization (forced PWM)

Beating frequency noise is an issue when multiple switching regulators populate the same application board. The L3751 synchronization circuitry features the same switching frequency for a set of regulators simply connecting the SYNCOUT of the master to the SYNCIN of the slaves together, so preventing beating noise. The master device provides the synchronization signal to the others.

For proper synchronization of multiple regulators, all of them have to be configured with the same switching frequency (see Section 5.2), so the same resistor value connected at the RT pin. Alternatively, the SINCIN can be driven by an external clock signal in accordance with electrical parameters defined in Table 7. The external clock frequency range at SYNCIN pin is -20% to +50% of the programmed oscillator frequency with the RT resistor.

In order to minimize the RMS current flowing through the input filter and improve overall EMC performance, the L3751 device provides a phase shift of 180° between the master and the slaves. If more than two devices are synchronized, the phase shift is fixed and all slaves have a common 180° phase shift with respect to the master. Considering two L3751 operating synchronized which regulate the same output voltage (i.e.: operating with the same duty cycle), the input filter RMS current is minimized and is calculated as:

$$I_{RMS} = \begin{cases} \frac{I_{OUT}}{2} \cdot \sqrt{2D \cdot (1 - 2D)} & \text{if } D < 0.5 \\ \frac{I_{OUT}}{2} \cdot \sqrt{(2D - 1) \cdot (2 - 2D)} & \text{if } D > 0.5 \end{cases} \quad (26)$$

The graphical representation of the input RMS current of the input filter in the case of two devices with 0° phase shift (synchronized to an external signal) or 180° phase shift (synchronized connecting their SYNCH pins) regulating the same output voltage.

### 8.3 PCB board layout

The PCB board design is a crucial factor for the final application EMC and for the proper device operation in buck converter topology, which is critical for inherent high dv/dt pulsed current paths. The scenario gets even more complex for a controller with external MOSFETs because of additional gate-driving paths that are often internally optimized in a monolithic device.

Figure 30. Pulsed current paths in buck topology

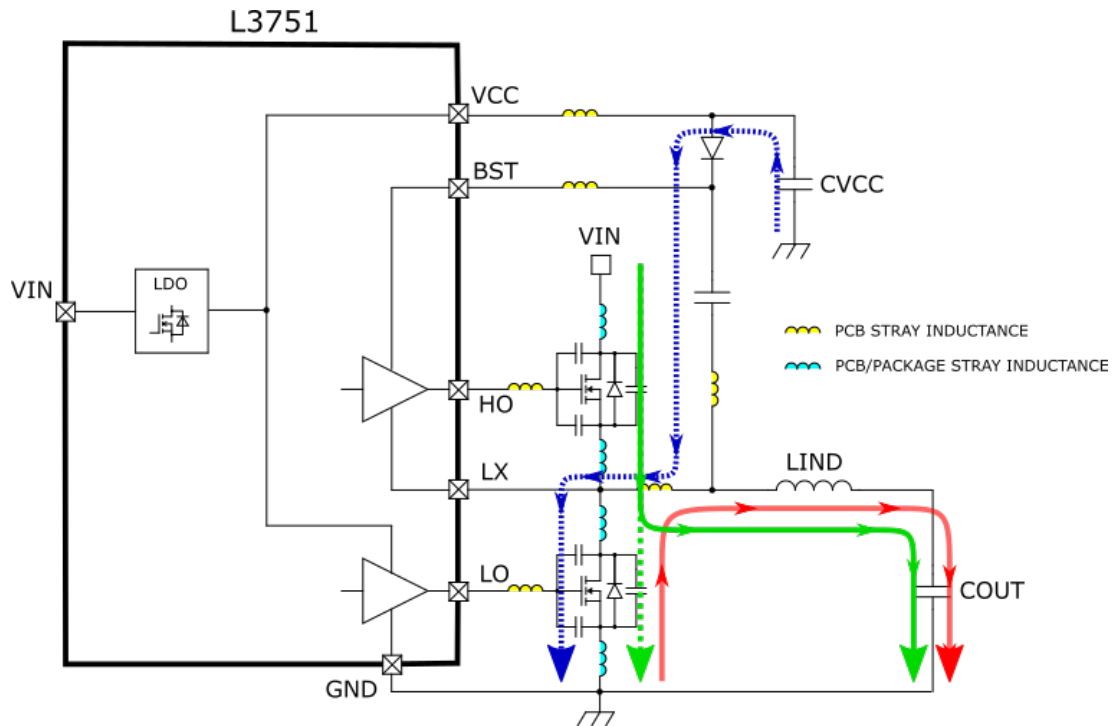


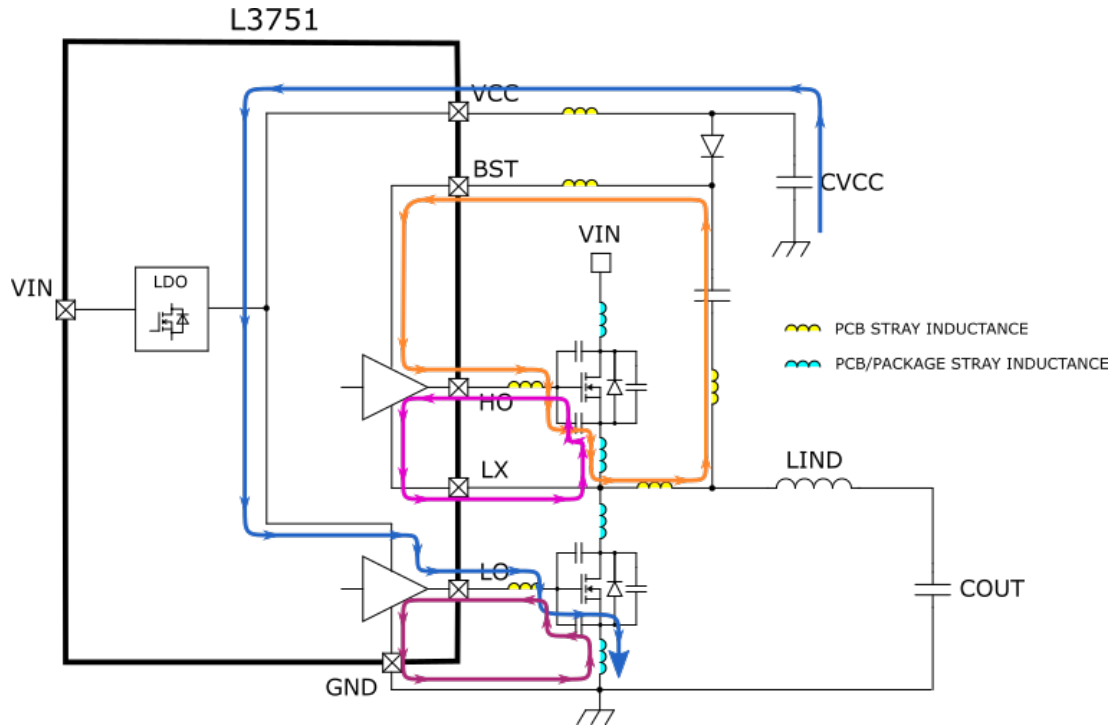
Figure 30 shows the current paths in buck topology: at TON inception, when the HS (“high-side switch”) is closed, an impulsive current, green-dotted trace, flows from VIN to the LS (“low-side switch”) diode to recover the majority gate charge in spatial zone; that is the  $Q_{rr}$  for the diode reverse recovery operation from forward biasing. This pulsed current level can be much higher than load current: the gate charge amount depends on the diode p-n junction and the peak current is limited only by parasitic. When the diode is reverse bias, the LX node rises and the HS current becomes the inductor current, so the output current ripple included, which is the green trace.

Contrary to the HS turn-off, the inductor current starts to flow through the LS body-diode during the deadtime and then through the LS, when enabled by the anti-cross conduction circuitry. At the same time, the blue-dotted trace current, flowing from VCC to the LX node grounded, restores the HS gate charge spent during TON on the bootstrap capacitor and compensates for the HS driver current consumption.

The quoted switched currents may generate voltage spikes caused by inductive parasitic components related to the PCB board traces and package bonding wires of the external power components.

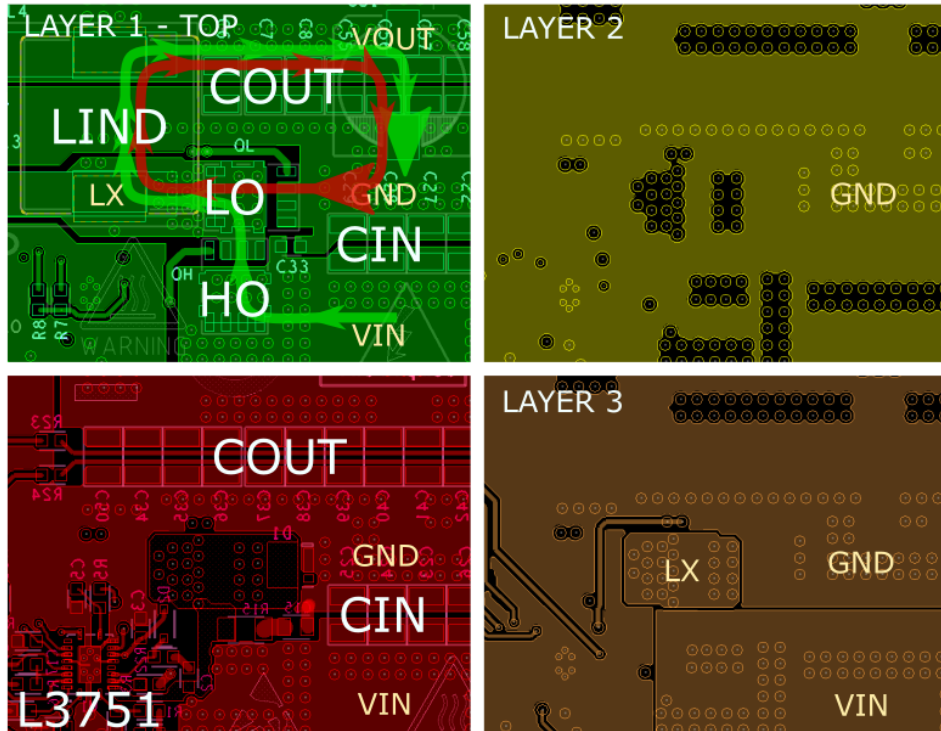
In addition to that described above, which applies to a monolithic device with power elements embedded, a controller with external MOSFETs like the L3751 has additional gate-driving loops for the external MOSFETs, as shown in Figure 31.

**Figure 31. High frequency gate-driving loops**



The orange and blue traces represent the turning-on paths for HS and LS respectively, whilst purple and dark red traces the external MOSFETs turning-off paths. All these loops operate at the switching frequency, high  $dv/dt$  with current capability limited by the internal MOSFETs of the drivers (few ohms).

Figure 32. Board layout example



Consequently, as anticipated at the beginning of the section, the external power component placing (Cin, Cboot, C<sub>vcc</sub>, diode and both power elements) and wire connection to minimize inductive parasitic components is critical for the device operation and EMC reduction. Figure 32 shows an example of optimized board layout in terms of component placing and wire trace design that keep the mentioned critical loops on the layer 1, preventing PCB via insertion in critical high frequency loops.



---

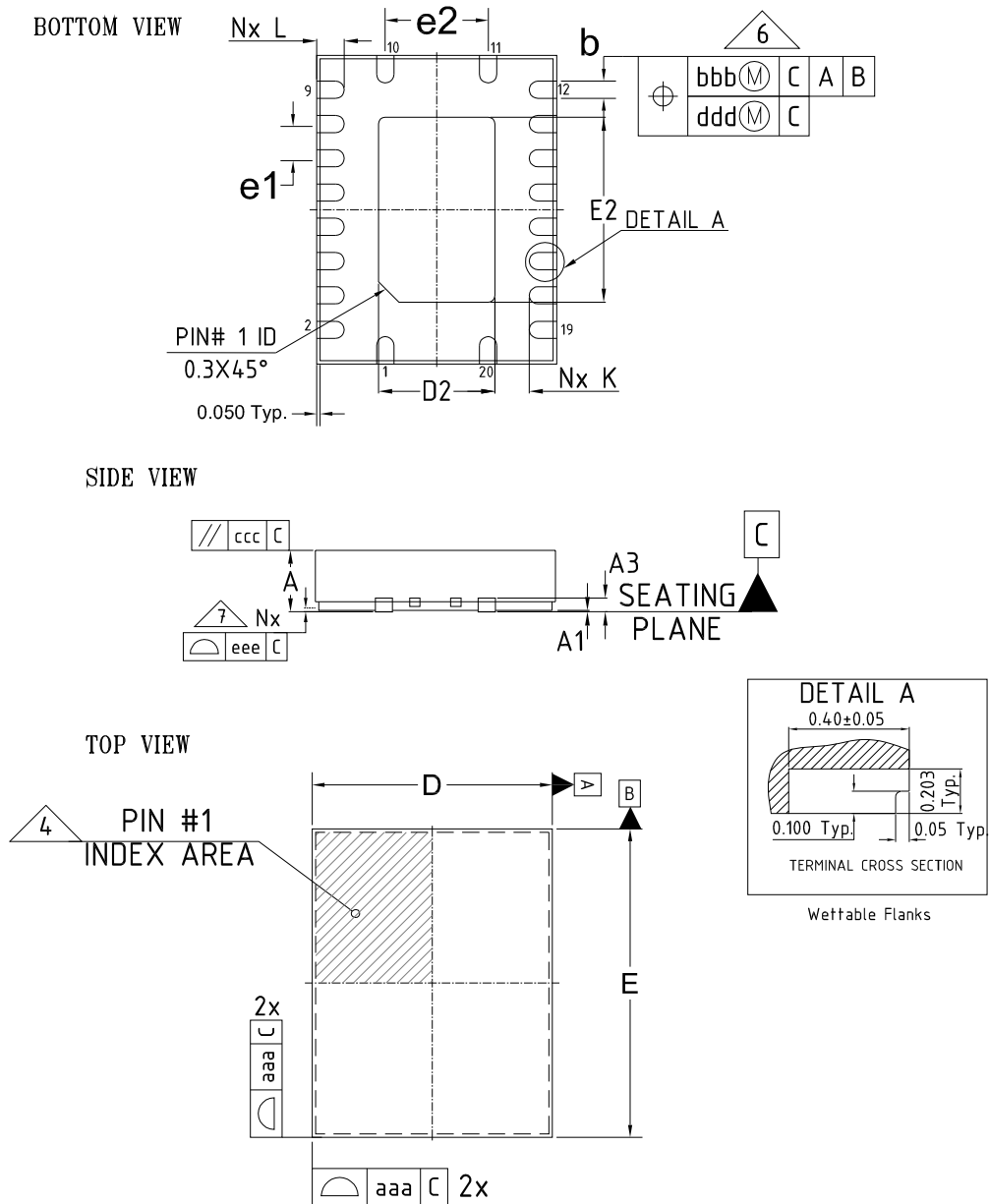
## 9 Package information

---

In order to meet environmental requirements, ST offers these devices in different grades of **ECOPACK** packages, depending on their level of environmental compliance. ECOPACK specifications, grade definitions and product status are available at: [www.st.com](http://www.st.com). ECOPACK is an ST trademark.

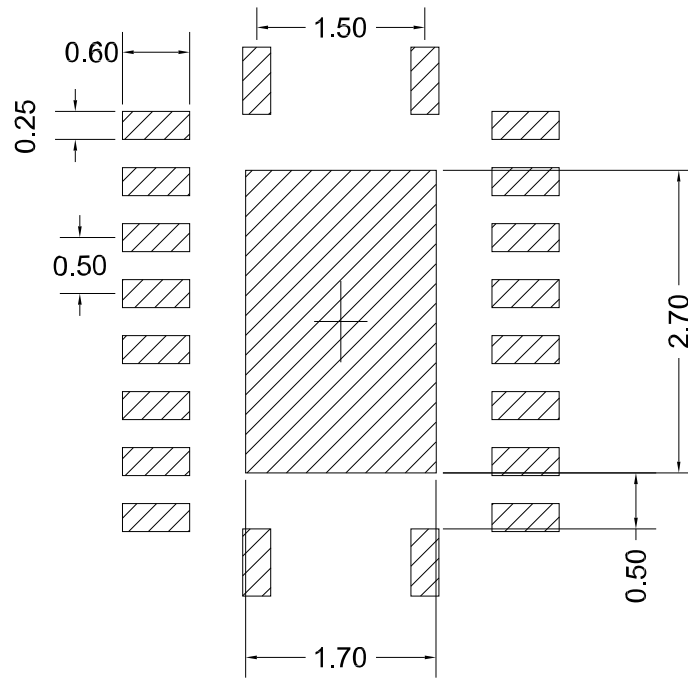
### 9.1 QFN20 (3.5 x 4.5 mm) package information

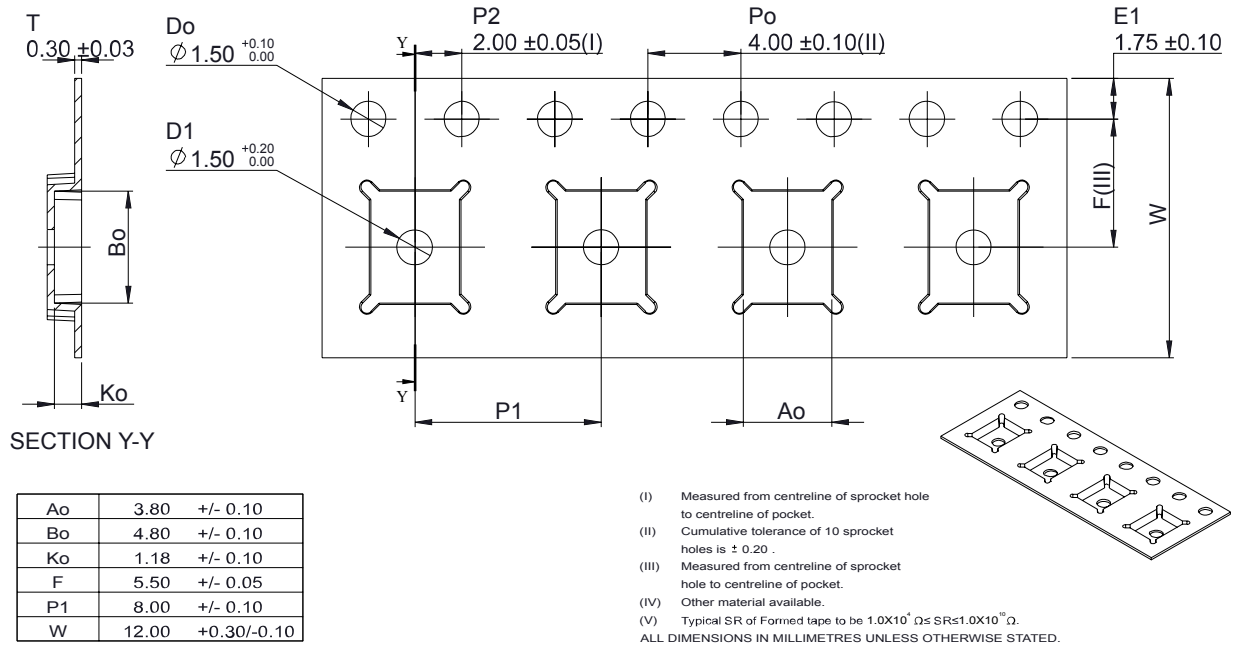
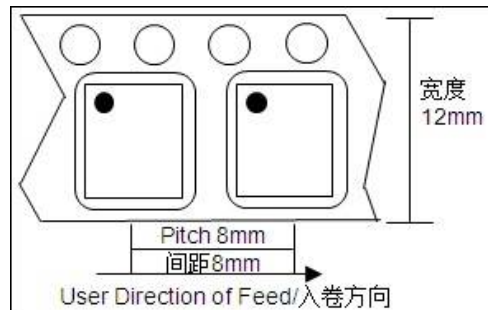
Figure 33. QFN20 (3.5 x 4.5 mm) package outline

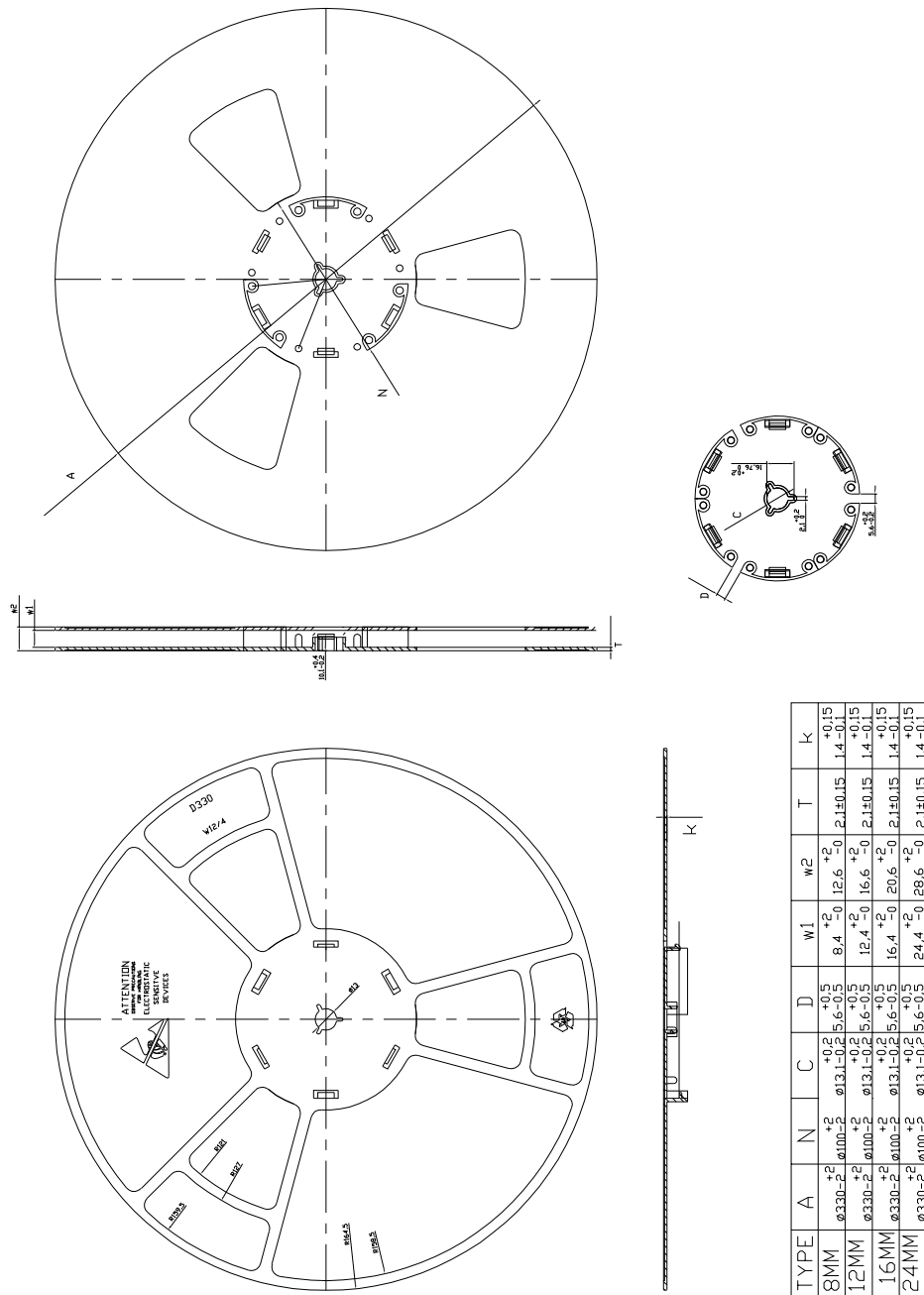


**Table 9. QFN20 (3.5 x 4.5 mm) mechanical data**

Dim.	mm		
	Min.	Typ.	Max.
A	0.80	0.90	1.00
A1	0.00	0.02	0.05
A3	0.203 Ref.		
b	0.20	0.25	0.30
D	3.50 BSC		
E	4.50 BSC		
e1	0.50 BSC		
e2	1.50 BSC		
D2	1.60	1.70	1.80
E2	2.60	2.70	2.80
K	0.20	-	-
L	0.30	0.40	0.50
N	20		
ND	2		
NE	8		
aaa	0.05		
bbb	0.10		
ccc	0.10		
ddd	0.05		
eee	0.08		

**Figure 34. QFN20 (3.5 x 4.5 mm) recommended footprint**


**9.2 QFN20 (3.5 x 4.5 mm) packing information**
**Figure 35. QFN20 (3.5 x 4.5 mm) tape drawing**

**Figure 36. QFN20 (3.5 x 4.5 mm) tape oriented**


**Figure 37. QFN20 (3.5 x 4.5 mm) reel dimensions**


## Revision history

**Table 10. Document revision history**

Date	Revision	Changes
08-Apr-2022	1	Initial release.
06-Dec-2022	2	Updated <a href="#">Table 1</a> . Pin description Updated <a href="#">Section 6.5</a> Embedded gate driver supply Added <a href="#">Figure 13</a> . VCC power circuite

## Contents

<b>1</b>	<b>Diagram</b> .....	<b>2</b>
<b>2</b>	<b>Pin configuration</b> .....	<b>3</b>
<b>3</b>	<b>Typical application circuit</b> .....	<b>5</b>
<b>4</b>	<b>Maximum ratings</b> .....	<b>7</b>
<b>5</b>	<b>Electrical characteristics</b> .....	<b>8</b>
<b>6</b>	<b>Functional description</b> .....	<b>12</b>
<b>6.1</b>	Precision enable .....	12
<b>6.2</b>	Oscillator and synchronization .....	13
<b>6.3</b>	Soft-start .....	14
<b>6.4</b>	Error amplifier .....	17
<b>6.5</b>	Embedded gate driver supply .....	17
<b>6.6</b>	Light load operation .....	18
<b>6.7</b>	Overcurrent protection .....	21
<b>7</b>	<b>Closing the loop</b> .....	<b>24</b>
<b>7.1</b>	Total transfer function .....	24
<b>7.2</b>	Type II compensation network .....	25
<b>7.3</b>	Type III compensation network .....	26
<b>8</b>	<b>Application notes</b> .....	<b>29</b>
<b>8.1</b>	Output voltage divider .....	29
<b>8.2</b>	Synchronization (forced PWM) .....	29
<b>8.3</b>	PCB board layout .....	30
<b>9</b>	<b>Package information</b> .....	<b>33</b>
<b>9.1</b>	QFN20 (3.5 x 4.5 mm) package information .....	34
<b>9.2</b>	QFN20 (3.5 x 4.5 mm) packing information .....	37
	<b>Revision history</b> .....	<b>39</b>



## List of tables

<b>Table 1.</b>	Pin description . . . . .	3
<b>Table 2.</b>	Schematic application components description . . . . .	6
<b>Table 3.</b>	Absolute maximum ratings . . . . .	7
<b>Table 4.</b>	Thermal data . . . . .	7
<b>Table 5.</b>	ESD performance . . . . .	7
<b>Table 6.</b>	Recommended operating conditions . . . . .	7
<b>Table 7.</b>	Electrical characteristics . . . . .	8
<b>Table 8.</b>	Error amplifier characteristic . . . . .	17
<b>Table 9.</b>	QFN20 (3.5 x 4.5 mm) mechanical data . . . . .	35
<b>Table 10.</b>	Document revision history . . . . .	39

## List of figures

<b>Figure 1.</b>	Simplified block diagram . . . . .	2
<b>Figure 2.</b>	QFN pin connection (top view) . . . . .	3
<b>Figure 3.</b>	Typical application. . . . .	5
<b>Figure 4.</b>	EN / UVLO resistor divider . . . . .	12
<b>Figure 5.</b>	$R_{RT}$ resistor value for $f_{SW}$ programming . . . . .	13
<b>Figure 6.</b>	Internal sawtooth ramp feedforward - voltage feed forward . . . . .	14
<b>Figure 7.</b>	Internal sawtooth ramp feedforward - Fsw adjusted by external resistor . . . . .	14
<b>Figure 8.</b>	Soft-start block diagram . . . . .	15
<b>Figure 9.</b>	Soft-start phase . . . . .	15
<b>Figure 10.</b>	Schematic to implement input voltage tracking . . . . .	16
<b>Figure 11.</b>	Input voltage tracking . . . . .	16
<b>Figure 12.</b>	SS/TRK clamper operation . . . . .	17
<b>Figure 13.</b>	VCC power circuit . . . . .	18
<b>Figure 14.</b>	DEM vs. FPWM management in light load condition . . . . .	18
<b>Figure 15.</b>	DEM to FPWM smooth transition in 1000 clks at powerup . . . . .	19
<b>Figure 16.</b>	Efficiency typ. @ 240 KHz, $V_{OUT} = 5 V$ . . . . .	19
<b>Figure 17.</b>	Efficiency typ. @ 240 KHz, $V_{OUT} = 12 V$ . . . . .	19
<b>Figure 18.</b>	Efficiency typ. @ 240 KHz DEM vs. FPWM . . . . .	20
<b>Figure 19.</b>	DEM output voltage ripple at zero load . . . . .	20
<b>Figure 20.</b>	FPWM output voltage ripple at zero load . . . . .	21
<b>Figure 21.</b>	$R_{LIM}$ resistor connection to define lossless and precise OCP setting . . . . .	21
<b>Figure 22.</b>	Constant current in persistent short-circuit . . . . .	22
<b>Figure 23.</b>	Hiccup in persistent short-circuit . . . . .	22
<b>Figure 24.</b>	Voltage mode control loop . . . . .	24
<b>Figure 25.</b>	Type II compensation network . . . . .	25
<b>Figure 26.</b>	Type II compensation - Bode plot . . . . .	26
<b>Figure 27.</b>	Type III compensation network . . . . .	26
<b>Figure 28.</b>	Type III compensation - Bode plot . . . . .	28
<b>Figure 29.</b>	L3751 application schematic . . . . .	29
<b>Figure 30.</b>	Pulsed current paths in buck topology . . . . .	30
<b>Figure 31.</b>	High frequency gate-driving loops . . . . .	31
<b>Figure 32.</b>	Board layout example . . . . .	32
<b>Figure 33.</b>	QFN20 (3.5 x 4.5 mm) package outline . . . . .	34
<b>Figure 34.</b>	QFN20 (3.5 x 4.5 mm) recommended footprint . . . . .	36
<b>Figure 35.</b>	QFN20 (3.5 x 4.5 mm) tape drawing . . . . .	37
<b>Figure 36.</b>	QFN20 (3.5 x 4.5 mm) tape oriented . . . . .	37
<b>Figure 37.</b>	QFN20 (3.5 x 4.5 mm) reel dimensions . . . . .	38

**IMPORTANT NOTICE – READ CAREFULLY**

STMicroelectronics NV and its subsidiaries (“ST”) reserve the right to make changes, corrections, enhancements, modifications, and improvements to ST products and/or to this document at any time without notice. Purchasers should obtain the latest relevant information on ST products before placing orders. ST products are sold pursuant to ST’s terms and conditions of sale in place at the time of order acknowledgment.

Purchasers are solely responsible for the choice, selection, and use of ST products and ST assumes no liability for application assistance or the design of purchasers’ products.

No license, express or implied, to any intellectual property right is granted by ST herein.

Resale of ST products with provisions different from the information set forth herein shall void any warranty granted by ST for such product.

ST and the ST logo are trademarks of ST. For additional information about ST trademarks, refer to [www.st.com/trademarks](http://www.st.com/trademarks). All other product or service names are the property of their respective owners.

Information in this document supersedes and replaces information previously supplied in any prior versions of this document.

© 2022 STMicroelectronics – All rights reserved