

Smart LED driver using 6LoWPAN Mesh network for outdoor street lighting

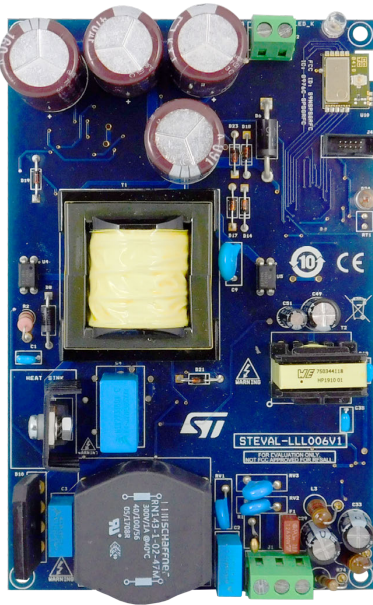

Features

- Intelligent power conversion stage based on the HVLED001A high voltage LED driver:
 - wide input voltage range: 90 – 300 V_{AC}
 - constant current output: 60-110 V / 0.7 A, with ±5% current regulation
 - high power factor > 0.97 and low THD <15% for entire line and load cycle in quasi resonant mode
 - peak overall efficiency (including auxiliary supply) at maximum load > 89%
 - various start-up, operating and low-power modes
 - open circuit, short-circuit, undervoltage and overvoltage circuit protection
- Digital and remote control section based on STM32 microcontroller:
 - wireless connectivity with embedded sub-1 GHz transceiver
 - can accept remote on, off and dimming commands
- Five levels of analog dimming
- Less than 0.5 W standby power consumption ensures compliance with EnergyStar norms
- RoHS compliant
- WEEE compliant

Description

The [STEVAL-LLL006V1](#) board is designed to help you evaluate high power LED lighting solutions with comprehensive power management and wireless connectivity.

The board integrates an intelligent power conversion stage thanks to the [HVLED001A](#) LED lighting controller with various operating modes, sensing and protection mechanisms, and highly efficient switching based on the [STP21N90K5](#) Power MOSFET. The board is able to convert a wide 90 - 300 V_{AC} input voltage range into a 60 - 110 V_{DC} output in constant current mode, with high power factor and low THD.

The on-board [STM32L071KZ](#) microcontroller is able to receive remote on, off and dimming commands via the embedded [SPSGRFC](#) sub-1 GHz transceiver module.

A data concentrator unit (DCU) and mobile Android application have been developed to help you explore the functionality of the evaluation board. The DCU consists of a NUCLEO-F401RE development platform, plus the X-NUCLEO-IDS01A4 for sub 1-GHz communication with the LED driver board and a X-NUCLEO-IDB05A1 board for Bluetooth communication with the mobile device.

The mobile application collects lighting nodes represented by the microcontroller and RF module on the evaluation board in a 6LoWPAN mesh network.

Summary table

Smart LED Driver using 6LoWPAN Mesh network for outdoor street lighting	STEVAL-LLL006V1
high voltage controller for LED lighting	HVLED001A
N-channel 900 V, 0.25 Ω typ., 18.5 A MDmesh K5 Power MOSFET	STP21N90K5
ultra-low-power ARM Cortex-M0+ MCU	STM32L071KZ
sub-1 GHz programmable transceiver module	SPSGRFC
VIPerPlus family: Low voltage energy saving fixed frequency high voltage converter	VIPER012LS

1 Block diagram

Figure 1. Block diagram

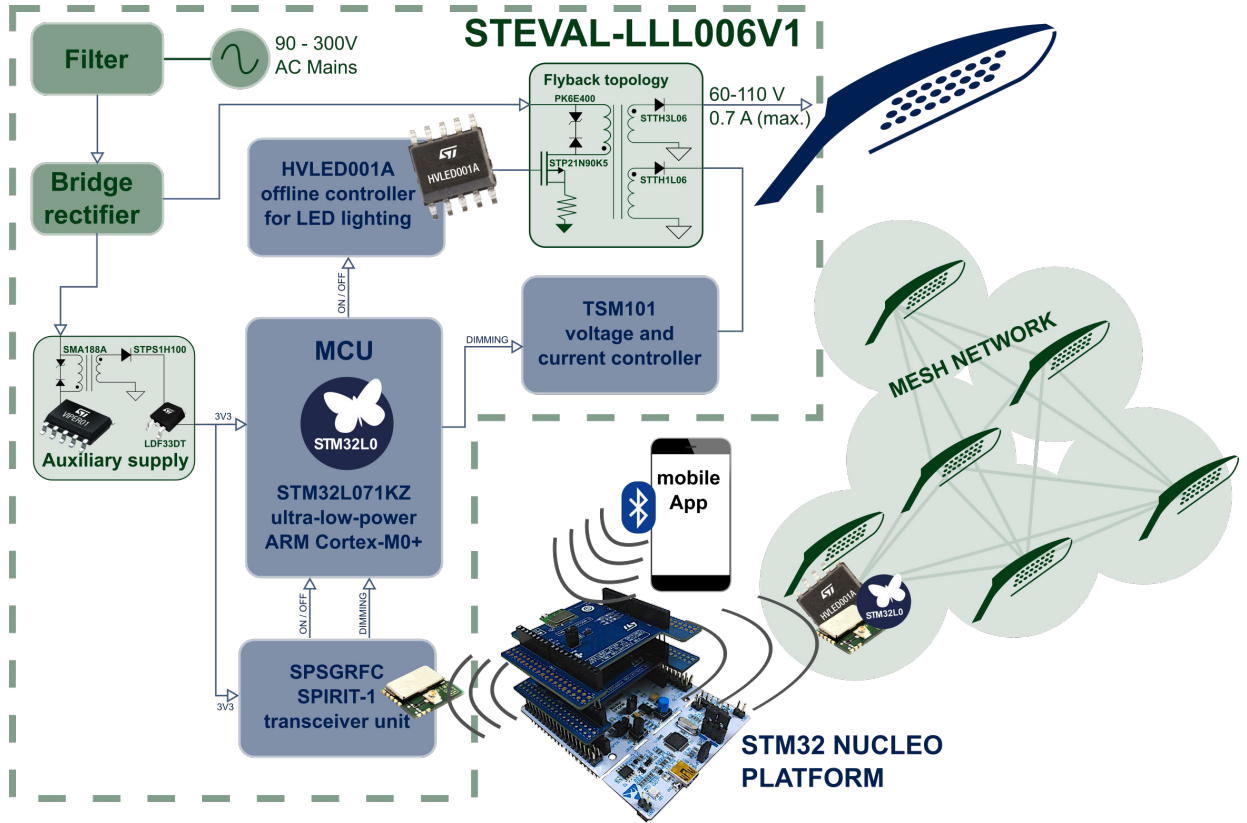

2 Schematic diagrams

Figure 2. STEVAL-LLL006V1 board schematic

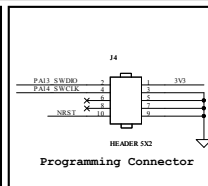
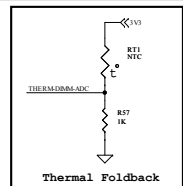
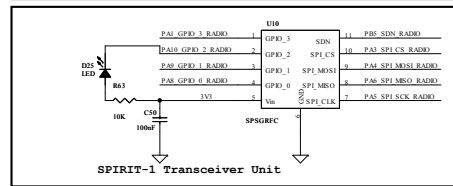
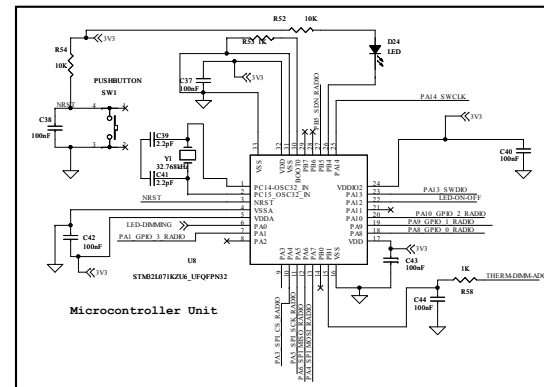
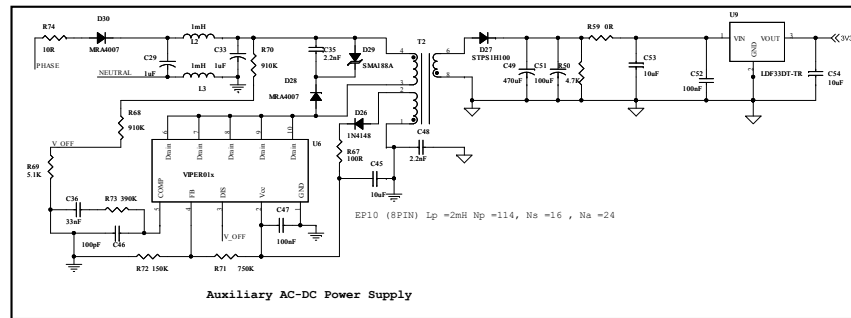
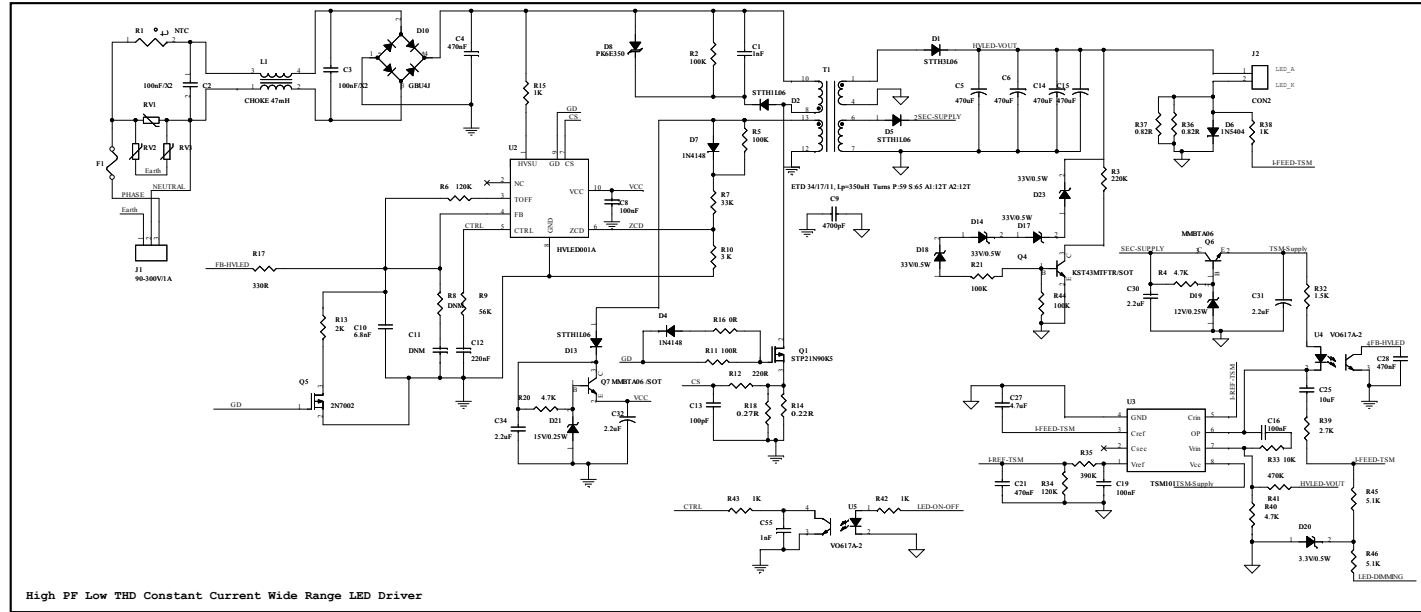

Revision history

Table 1. Document revision history

Date	Version	Changes
28-Jul-2019	1	Initial release.

IMPORTANT NOTICE – PLEASE READ CAREFULLY

STMicroelectronics NV and its subsidiaries (“ST”) reserve the right to make changes, corrections, enhancements, modifications, and improvements to ST products and/or to this document at any time without notice. Purchasers should obtain the latest relevant information on ST products before placing orders. ST products are sold pursuant to ST’s terms and conditions of sale in place at the time of order acknowledgement.

Purchasers are solely responsible for the choice, selection, and use of ST products and ST assumes no liability for application assistance or the design of Purchasers’ products.

No license, express or implied, to any intellectual property right is granted by ST herein.

Resale of ST products with provisions different from the information set forth herein shall void any warranty granted by ST for such product.

ST and the ST logo are trademarks of ST. For additional information about ST trademarks, please refer to www.st.com/trademarks. All other product or service names are the property of their respective owners.

Information in this document supersedes and replaces information previously supplied in any prior versions of this document.

© 2019 STMicroelectronics – All rights reserved