



250MHz, Rail-to-Rail Output CMOS Operational Amplifier

FEATURES

- **HIGH GAIN BANDWIDTH:250MHz**
- **RAIL-TO-RAIL OUTPUT**
- **1.5mV Typical Vos**
- **INPUT VOLTAGE RANGE: -0.2V to +3.9V**
with $V_s = 5V$
- **SUPPLY RANGE: +2.5V to +5.5V**
- **SPECIFIED UP TO +125°C**
- **Micro SIZE PACKAGES: SOT23-5**

APPLICATIONS

- **AUDIO ADC INPUT BUFFERS**
- **PHOTODIODE PREAMP**
- **HIGH-DENSITY SYSTEMS**
- **PORTABLE SYSTEMS**
- **DRIVING A/D CONVERTERS**

DESCRIPTION

The RS875X families of voltage-feedback (VFB) products offer low voltage operation, negative-rail input, rail-to-rail output, as well as excellent speed/power consumption ratio, providing an excellent bandwidth (250MHz) and slew rate of 180V/us. The op-amps are unity gain stable and feature an ultra-low input bias current.

These amplifiers set an industry-leading power-to-performance ratio for rail-to-rail amplifiers. The RS875X families of operational amplifiers are specified at the full temperature range of $-40^{\circ}C$ to $+125^{\circ}C$ under single or dual power supplies of 2.5V to 5.5V.

PIN CONFIGURATIONS

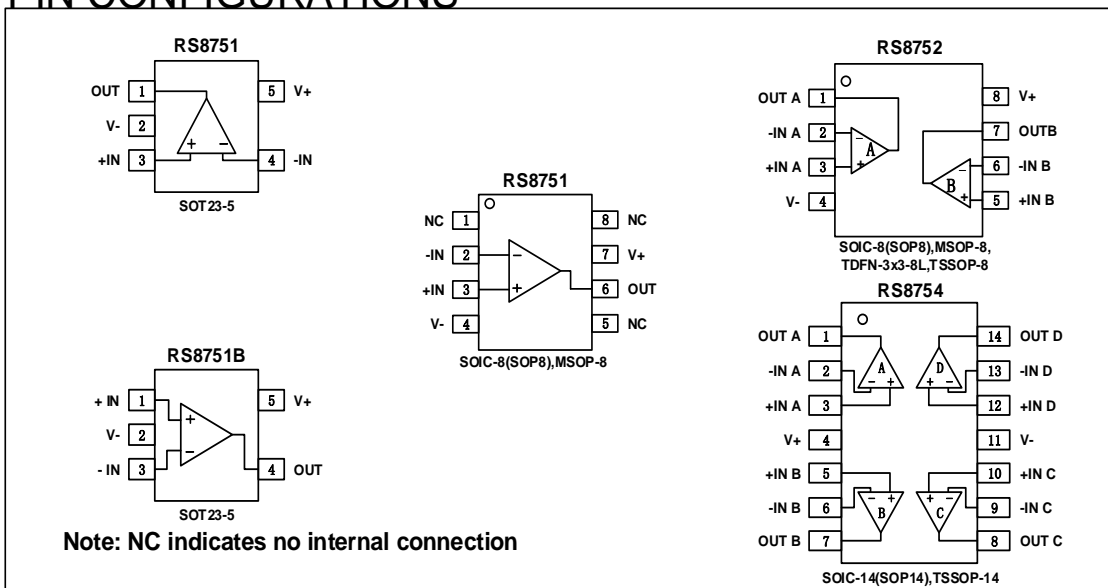

ABSOLUTE MAXIMUM RATINGS (1)

| | |
|---|----------------------|
| Supply Voltage, V+ to V-..... | 7.0V |
| Input Terminals, Voltage (2) | - 0.5 to (V+) + 0.5V |
| Current (2)..... | ±10mA |
| Storage Temperature | -65°C to +150°C |
| Operating Temperature | -40°C to +125°C |
| Junction Temperature..... | 150°C |
| Package Thermal Resistance @ TA = +25°C | |
| SOT23-5, SOT23-6..... | 200°C/W |
| MSOP-10, SOIC-8 ,TSSOP-8..... | 150°C/W |
| SOIC-14, TSSOP-14..... | 100°C/W |
| Lead Temperature (Soldering, 10s) | 260°C |
| ESD Susceptibility | |
| HBM | 5000V |
| MM | 400V |



ESD SENSITIVITY CAUTION

ESD damage can range from subtle performance degradation to complete device failure. Precision integrated circuits may be more susceptible to damage because very small parametric changes could cause the device not to meet its published specifications.

(1) Stresses above these ratings may cause permanent damage. Exposure to absolute maximum conditions for extended periods may degrade device reliability. These are stress ratings only, and functional operation of the device at these or any other conditions beyond those specified is not implied.

(2) Input terminals are diode-clamped to the power-supply rails. Input signals that can swing more than 0.5V beyond the supply rails should be current-limited to 10mA or less.

PACKAGE/ORDERING INFORMATION

| PRODUCT | ORDERING NUMBER | TEMPERATURE RANGE | PACKAGE LEAD | PACKAGE MARKING | PACKAGE OPTION |
|---------|-----------------|-------------------|----------------|-----------------|--------------------|
| RS8751 | RS8751XK | -40°C~125°C | SOIC-8(SOP8) | RS8751 | Tape and Reel,2500 |
| | RS8751XF | -40°C~125°C | SOT23-5 | 8751 | Tape and Reel,3000 |
| | RS8751BXF | -40°C~125°C | SOT23-5 | 8751B | Tape and Reel,3000 |
| | RS8751XM | -40°C~125°C | MSOP-8 | RS8751 | Tape and Reel,3000 |
| RS8752 | RS8752XK | -40°C~125°C | SOIC-8(SOP8) | RS8752 | Tape and Reel,2500 |
| | RS8752XM | -40°C~125°C | MSOP-8 | RS8752 | Tape and Reel,3000 |
| | RS8752XTDC8 | -40°C~125°C | TDFN-3x3-8L | RS8752 | Tape and Reel,3000 |
| | RS8752XQ | -40°C~125°C | TSSOP-8 | RS8752 | Tape and Reel,3000 |
| RS8754 | RS8754XP | -40°C~125°C | SOIC-14(SOP14) | RS8754 | Tape and Reel,2500 |
| | RS8754XQ | -40°C~125°C | TSSOP-14 | RS8754 | Tape and Reel,3000 |



RS8751, RS8752, RS8754

ELECTRICAL CHARACTERISTICS

(At TA = +25°C, VS = 5V, G = +2, RF = 1K Ω, and RL = 1KΩ connected to VS/2, VIN_CM =VS/2, unless otherwise noted.)

| PARAMETER | | CONDITIONS | RS8751,RS8752,RS8754 | | | UNITS |
|---------------------------|------------------------------|-----------------------------------|----------------------|------|------|--------|
| | | | MIN | TYP | MAX | |
| POWER SUPPLY | | | | | | |
| Vs | Operating Voltage Range | | 2.5 | | 5.5 | V |
| IQ | Quiescent Current/Amplifier | | | 2.9 | 3.5 | mA |
| PSRR | Power-Supply Rejection Ratio | Vs=2.5V to 5.5V, Vcm=(V-)+0.5V | 70 | 90 | | dB |
| INPUT | | | | | | |
| Vos | Input Offset Voltage | Vcm=Vs/2 | | ±1.5 | ±7.5 | mV |
| ΔVos/ΔT | Input Offset Voltage Drift | Vcm=Vs/2, -40°C ≤ TA ≤125°C | | 4 | | μV/°C |
| IB | Input Bias Current | | | 1 | 10 | pA |
| Ios | Input Offset Current | | | 1 | 10 | pA |
| Vcm | Common-Mode Voltage Range | Vs= 5V | -0.2 | | 3.9 | V |
| CMRR | Common-Mode Rejection Ratio | Vs= 5.5V, Vcm=-0.2V to 3.5V | 66 | 85 | | dB |
| OUTPUT | | | | | | |
| AOL | Open-Loop Voltage Gain | Vs=5.0V, RL=1KΩ, Vo=Vs-0.2V | 95 | 110 | | dB |
| | | Vs=5.0V, RL=150Ω, Vo=Vs-0.3V | 78 | 85 | | dB |
| | Output Swing From Rail | RL=1KΩ | | 23 | | mV |
| Iout | Output Current Source | | | 85 | | mA |
| Iout | Output Current Sink | | | 125 | | mA |
| FREQUENCY RESPONSE | | | | | | |
| | Small-Signal Bandwidth | VOUT=100mVpp,G=1 | | 250 | | MHz |
| | | VOUT=100mVpp,G=2 | | 130 | | MHz |
| | | VOUT=100mVpp,G=5 | | 33 | | MHz |
| | | VOUT=100mVpp,G=10 | | 15 | | MHz |
| SR | Slew Rate | | | 180 | | V/us |
| GBP | Gain-Bandwidth Product | | | 250 | | MHz |
| PM | Phase Margin | | | 62 | | ° |
| NOISE | | | | | | |
| enp-p | Input Voltage Noise | f = 0.1 Hz to 10 Hz | | 13 | | μVpp |
| en | Input Voltage Noise Density | f = 1 MHz | | 8 | | nV/√Hz |

TYPICAL CHARACTERISTICS

At $T_A = +25^\circ\text{C}$, $V_S = 5\text{V}$, $G = +2$, $R_F = 1\text{K}\Omega$, and $R_L = 1\text{K}\Omega$ connected to $V_S/2$, $V_{IN_CM} = V_S/2$, unless otherwise noted

Non-Inverting Small-Signal Frequency Response

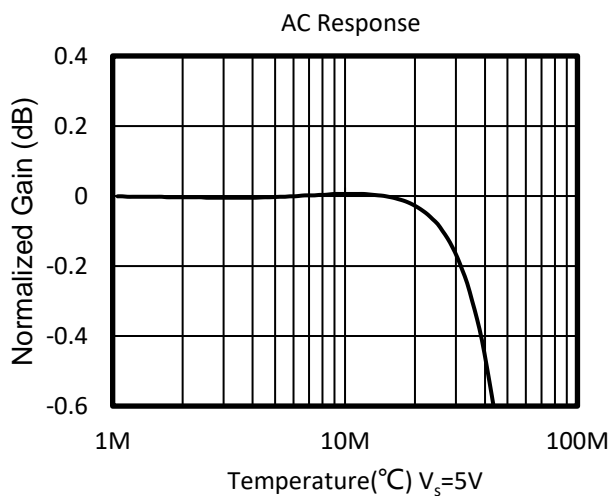
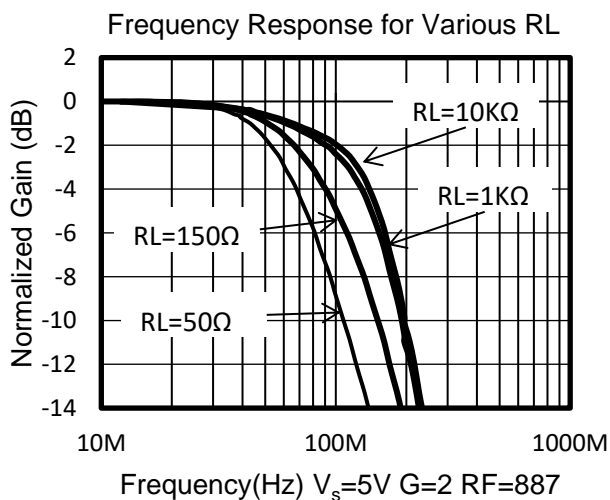
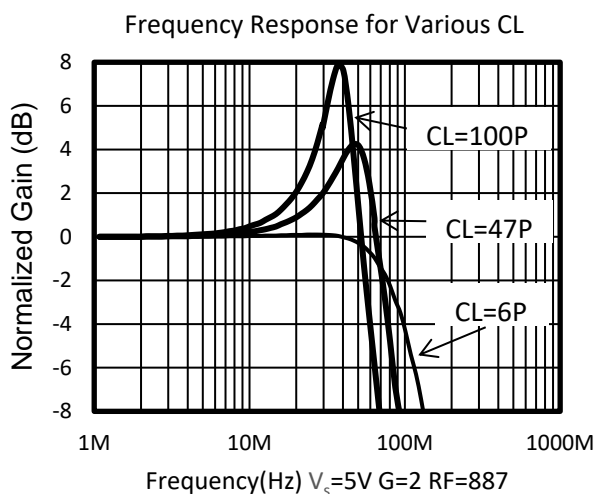
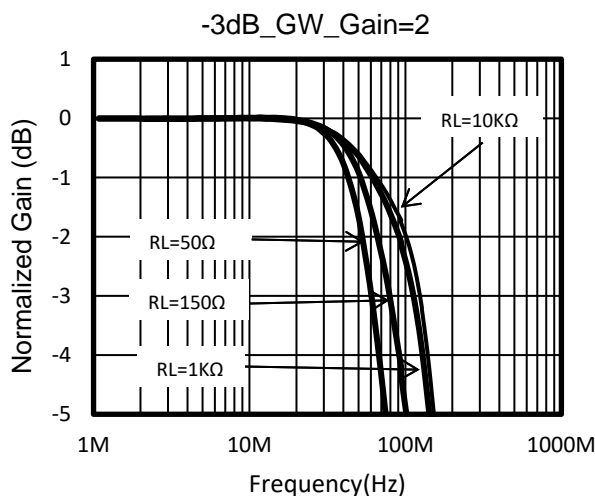
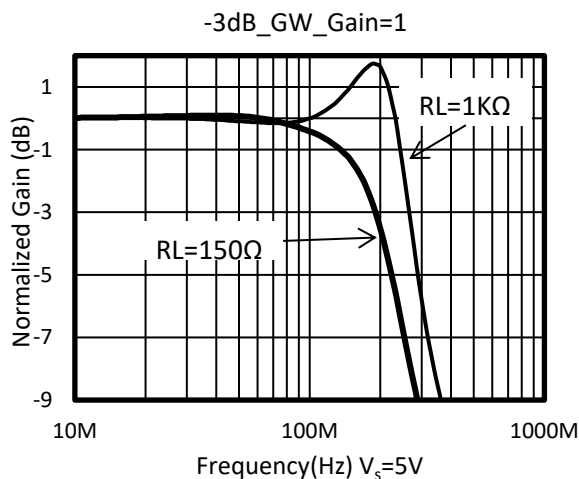
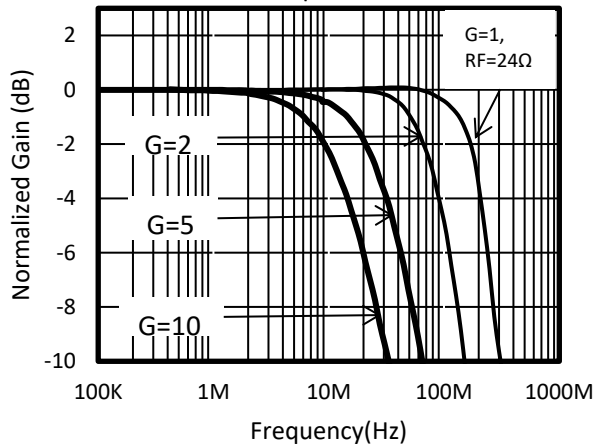



TYPICAL CHARACTERISTICS

At TA = +25°C, VS = 5V, G = +2, RF = 1K Ω, and RL = 1KΩ connected to VS/2, VIN_CM = VS/2, unless otherwise noted

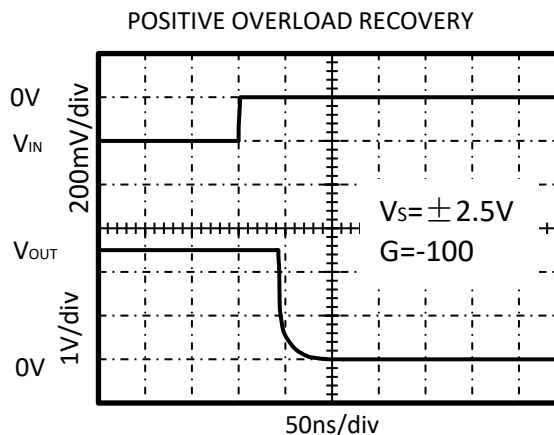
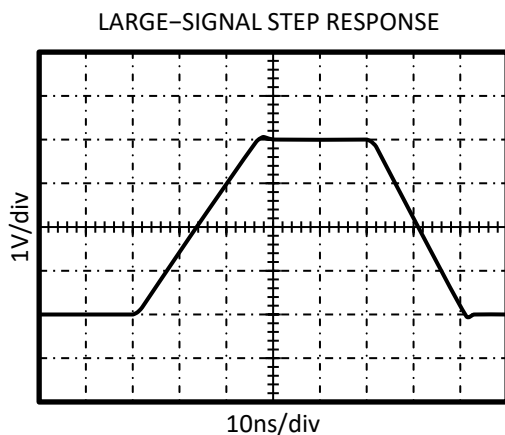
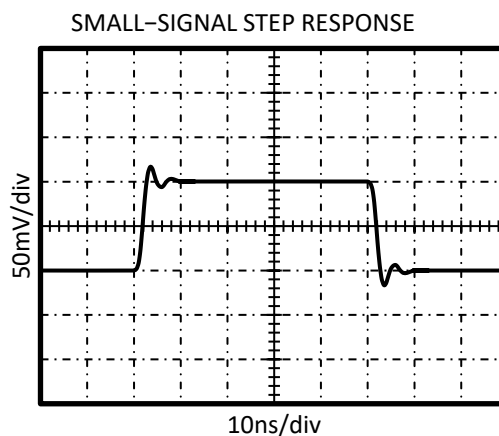
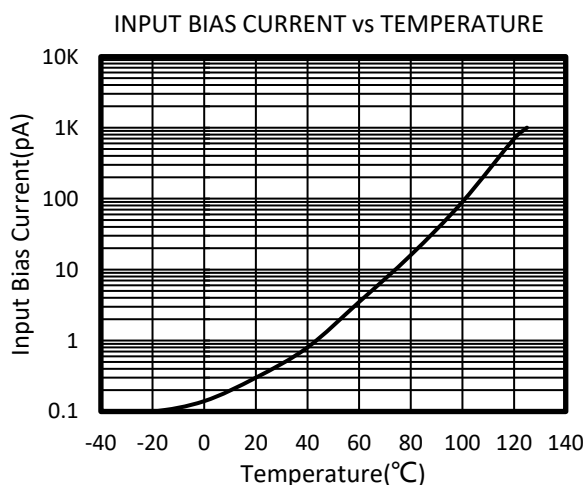
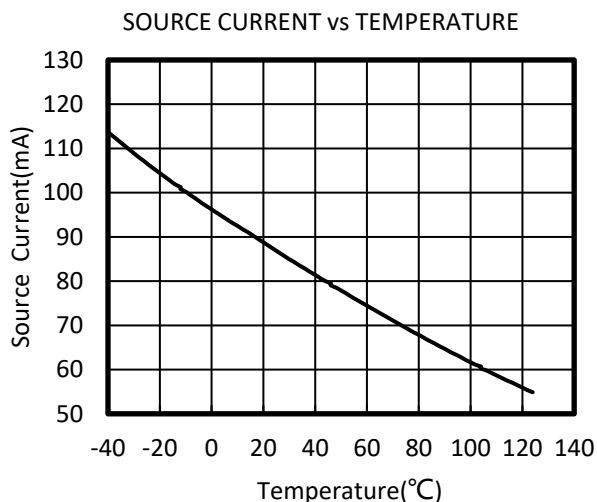
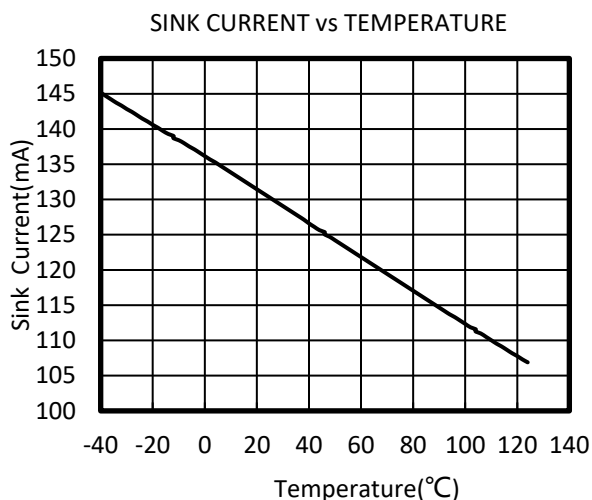

TYPICAL CHARACTERISTICS

At $T_A = +25^\circ\text{C}$, $V_S = 5\text{V}$, $G = +2$, $R_F = 1\text{K}\Omega$, and $R_L = 1\text{K}\Omega$ connected to $V_S/2$, $V_{IN_CM} = V_S/2$, unless otherwise noted

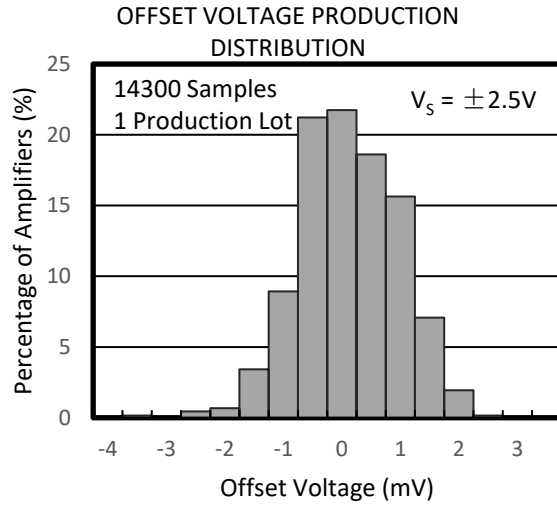
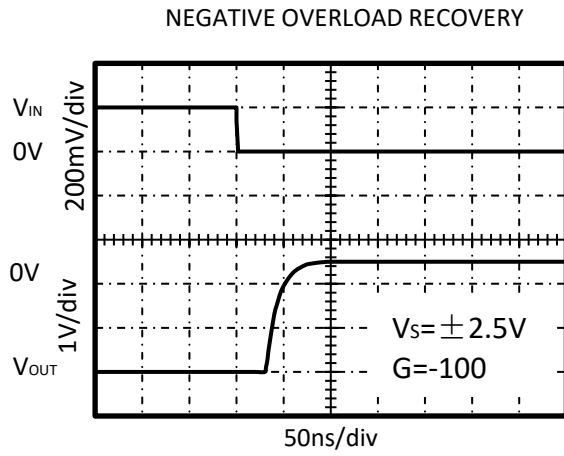

APPLICATION NOTES

The RS8751, RS8752, RS8754 are high precision, rail-to-rail operational amplifiers that can be run from a single-supply voltage 2.5V to 5.5V

($\pm 1.25V$ to $\pm 2.75V$). Supply voltages higher than 7V (absolute maximum) can permanently damage the amplifier.

Rail-to-rail input and output swing significantly increases dynamic range, especially in low-supply applications.

Good layout practice mandates use of a 0.1uF capacitor place closely across the supply pins.

LAYOUT GUIDELINS

Attention to good layout practices is always recommended. Keep traces short. When possible, use a PCB ground plane with surface-mount components placed as close to the device pins as possible. Place a 0.1uF capacitor closely across the supply pins.

These guidelines should be applied throughout the analog circuit to improve performance and provide benefits such as reducing the EMI susceptibility.

INSTRUMENTATION AMPLIFIER

In the three-op amp, instrumentation amplifier configuration shown in Figure2,

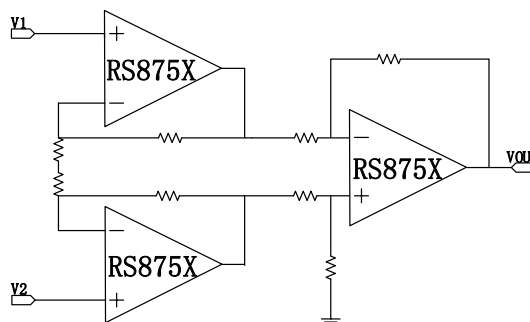

Figure2. Amplifier instrumentation amplifier

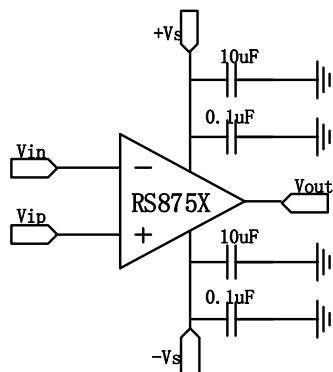
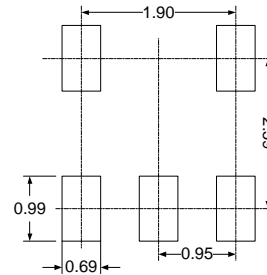
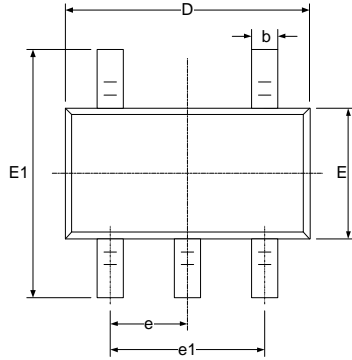

Figure1. Amplifier with Bypass Capacitors

PACKAGE OUTLINE DIMENSIONS

SOT23-5



RECOMMENDED LAND PATTERN (Unit: mm)

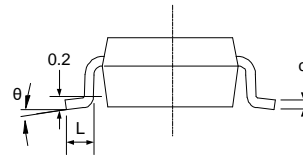
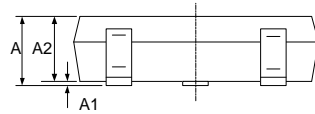

| Symbol | Dimensions In Millimeters | | Dimensions In Inches | |
|----------|---------------------------|-------|----------------------|-------|
| | Min | Max | Min | Max |
| A | 1.050 | 1.250 | 0.041 | 0.049 |
| A1 | 0.000 | 0.100 | 0.000 | 0.004 |
| A2 | 1.050 | 1.150 | 0.041 | 0.045 |
| b | 0.300 | 0.500 | 0.012 | 0.020 |
| c | 0.100 | 0.200 | 0.004 | 0.008 |
| D | 2.820 | 3.020 | 0.111 | 0.119 |
| E | 1.500 | 1.700 | 0.059 | 0.067 |
| E1 | 2.650 | 2.950 | 0.104 | 0.116 |
| e | 0.950(BSC) | | 0.037(BSC) | |
| e1 | 1.800 | 2.000 | 0.071 | 0.079 |
| L | 0.300 | 0.600 | 0.012 | 0.024 |
| θ | 0° | 8° | 0° | 8° |

MSOP-8

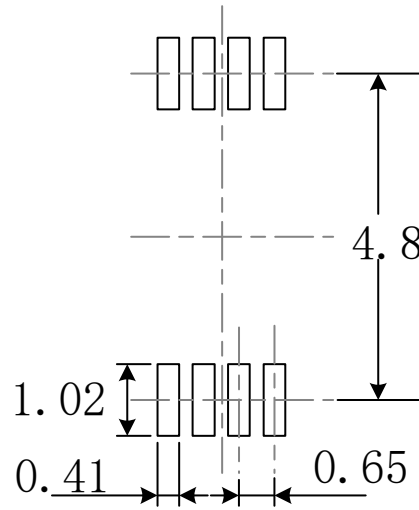
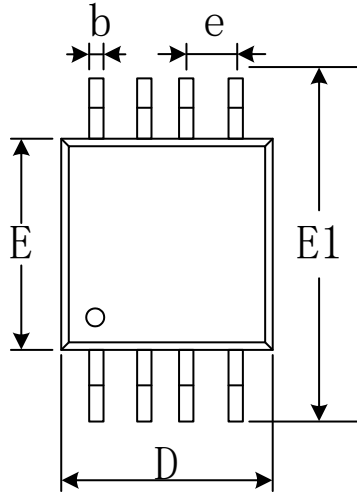

RECOMMENDED LAND PATTERN (Unit: mm)

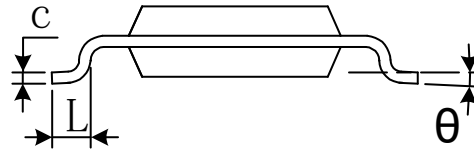
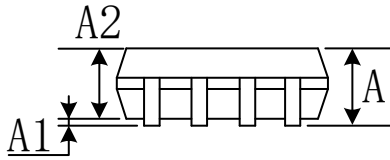

| Symbol | Dimensions In Millimeters | | Dimensions In Inches | |
|----------|---------------------------|-------|----------------------|-------|
| | Min | Max | Min | Max |
| A | 0.820 | 1.100 | 0.032 | 0.043 |
| A1 | 0.020 | 0.150 | 0.001 | 0.006 |
| A2 | 0.750 | 0.950 | 0.030 | 0.037 |
| b | 0.250 | 0.380 | 0.010 | 0.015 |
| c | 0.090 | 0.230 | 0.004 | 0.009 |
| D | 2.900 | 3.100 | 0.114 | 0.122 |
| e | 0.650(BSC) | | 0.026(BSC) | |
| E | 2.900 | 3.100 | 0.114 | 0.122 |
| E1 | 4.750 | 5.050 | 0.187 | 0.199 |
| L | 0.400 | 0.800 | 0.016 | 0.031 |
| θ | 0° | 6° | 0° | 6° |

TSSOP-8

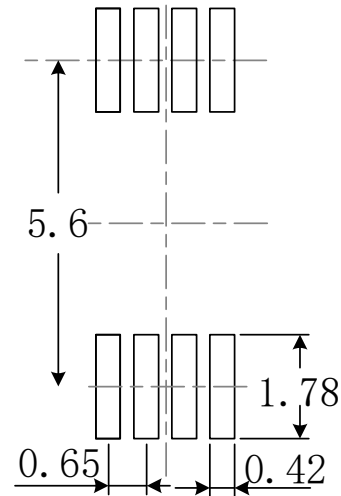
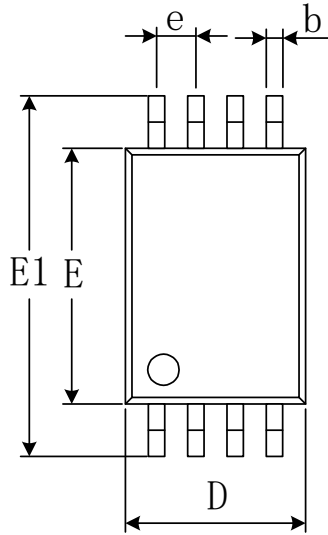

RECOMMENDED LAND PATTERN (Unit: mm)

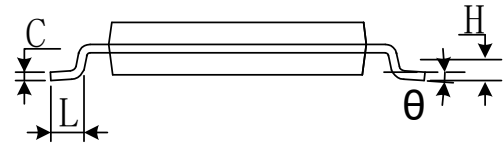
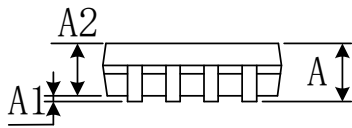

| Symbol | Dimensions In Millimeters | | Dimensions In Inches | |
|----------|---------------------------|-------|----------------------|-------|
| | Min | Max | Min | Max |
| A | | 1.200 | | 0.047 |
| A1 | 0.050 | 0.150 | 0.002 | 0.006 |
| A2 | 0.800 | 1.050 | 0.031 | 0.041 |
| b | 0.190 | 0.300 | 0.007 | 0.012 |
| c | 0.090 | 0.200 | 0.004 | 0.008 |
| D | 2.900 | 3.100 | 0.114 | 0.122 |
| E | 4.300 | 4.500 | 0.169 | 0.177 |
| E1 | 6.250 | 6.550 | 0.246 | 0.258 |
| e | 0.650(BSC) | | 0.026(BSC) | |
| L | 0.500 | 0.700 | 0.020 | 0.028 |
| H | 0.25(TYP) | | 0.01(TYP) | |
| θ | 1° | 7° | 1° | 7° |

TSSOP-14

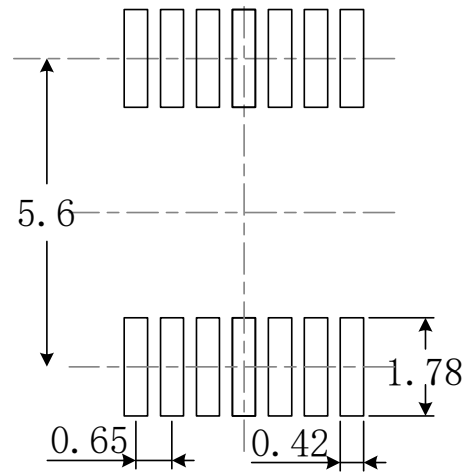
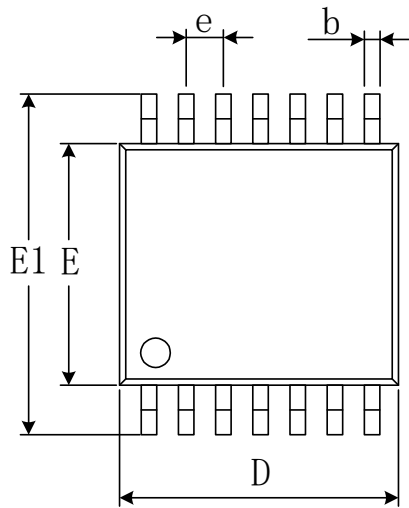

RECOMMENDED LAND PATTERN (Unit: mm)

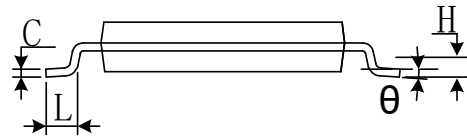
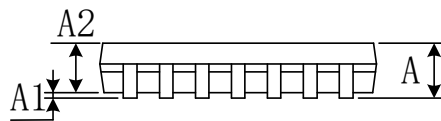

| Symbol | Dimensions In Millimeters | | Dimensions In Inches | |
|----------|---------------------------|-------|----------------------|-------|
| | Min | Max | Min | Max |
| A | | 1.200 | | 0.047 |
| A1 | 0.050 | 0.150 | 0.002 | 0.006 |
| A2 | 0.800 | 1.050 | 0.031 | 0.041 |
| b | 0.190 | 0.300 | 0.007 | 0.012 |
| c | 0.090 | 0.200 | 0.004 | 0.008 |
| D | 4.860 | 5.100 | 0.191 | 0.201 |
| E | 4.300 | 4.500 | 0.169 | 0.177 |
| E1 | 6.250 | 6.550 | 0.246 | 0.258 |
| e | 0.650(BSC) | | 0.026(BSC) | |
| L | 0.500 | 0.700 | 0.020 | 0.028 |
| H | 0.25(TYP) | | 0.01(TYP) | |
| θ | 1° | 7° | 1° | 7° |

SOIC-8(SOP8)

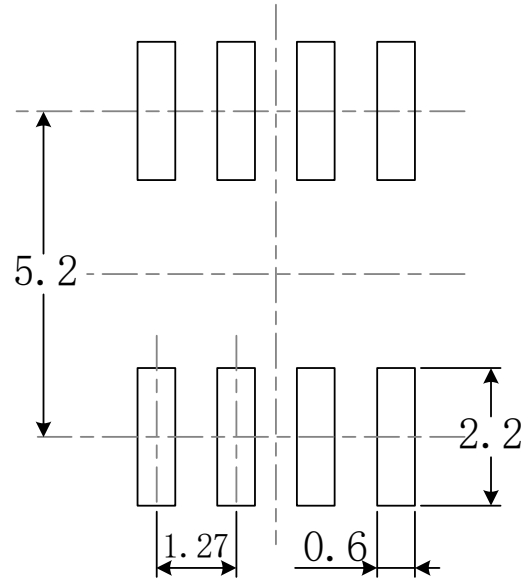
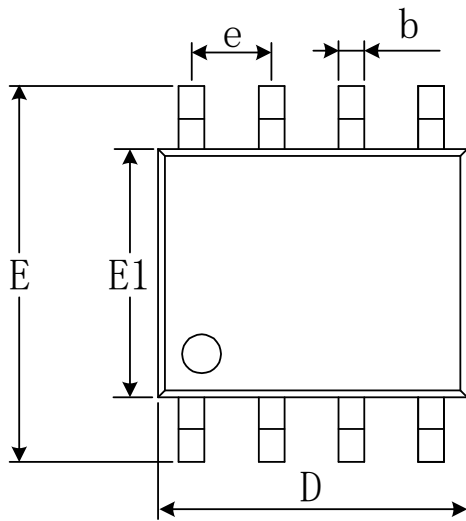

RECOMMENDED LAND PATTERN (Unit: mm)

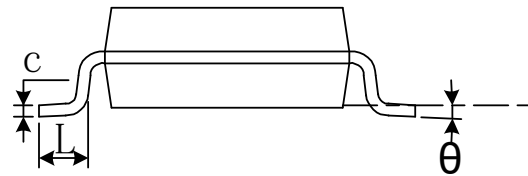
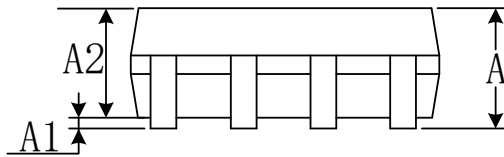

| Symbol | Dimensions In Millimeters | | Dimensions In Inches | |
|----------|---------------------------|-------|----------------------|-------|
| | Min | Max | Min | Max |
| A | 1.350 | 1.750 | 0.053 | 0.069 |
| A1 | 0.100 | 0.250 | 0.004 | 0.010 |
| A2 | 1.350 | 1.550 | 0.053 | 0.061 |
| b | 0.330 | 0.510 | 0.013 | 0.020 |
| c | 0.170 | 0.250 | 0.007 | 0.010 |
| D | 4.800 | 5.000 | 0.189 | 0.197 |
| e | 1.270(BSC) | | 0.050(BSC) | |
| E | 5.800 | 6.200 | 0.228 | 0.244 |
| E1 | 3.800 | 4.000 | 0.150 | 0.157 |
| L | 0.400 | 1.270 | 0.016 | 0.050 |
| θ | 0° | 8° | 0° | 8° |

SOIC-14(SOP14)

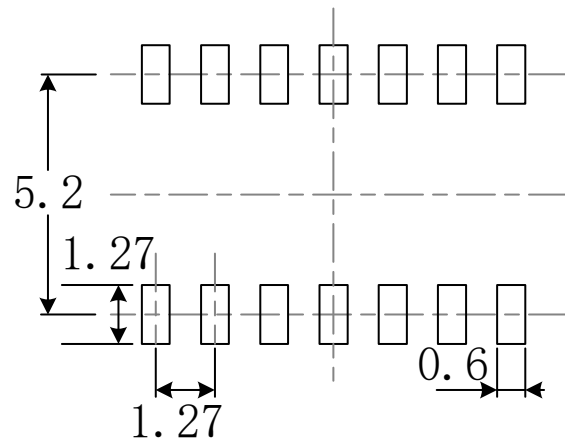
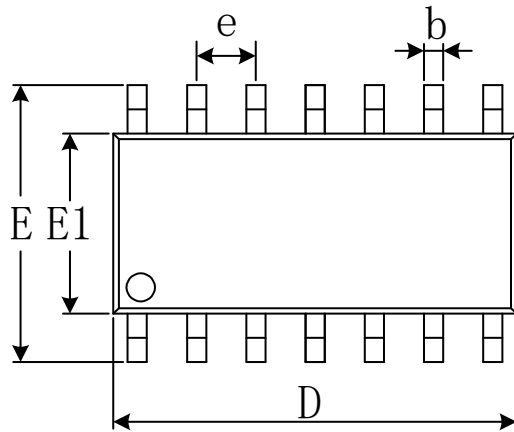

RECOMMENDED LAND PATTERN (Unit: mm)

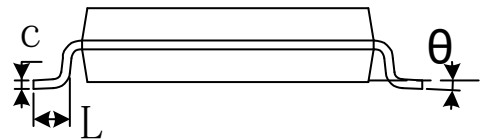
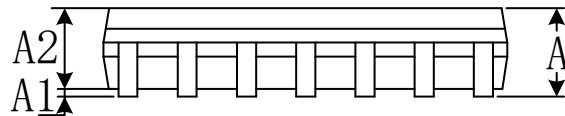

| Symbol | Dimensions In Millimeters | | Dimensions In Inches | |
|----------|---------------------------|-------|----------------------|-------|
| | Min | Max | Min | Max |
| A | 1.350 | 1.750 | 0.053 | 0.069 |
| A1 | 0.100 | 0.250 | 0.004 | 0.010 |
| A2 | 1.350 | 1.550 | 0.053 | 0.061 |
| b | 0.310 | 0.510 | 0.012 | 0.020 |
| c | 0.100 | 0.250 | 0.004 | 0.010 |
| D | 8.450 | 8.850 | 0.333 | 0.348 |
| e | 1.270(BSC) | | 0.050(BSC) | |
| E | 5.800 | 6.200 | 0.228 | 0.244 |
| E1 | 3.800 | 4.000 | 0.150 | 0.157 |
| L | 0.400 | 1.270 | 0.016 | 0.050 |
| θ | 0° | 8° | 0° | 8° |

TDFN-3x3-8L

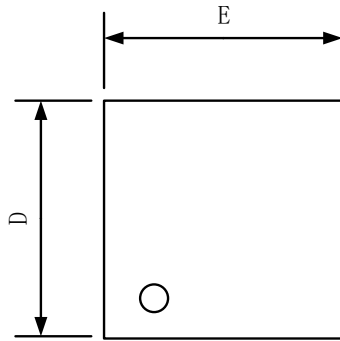

TOP VIEW

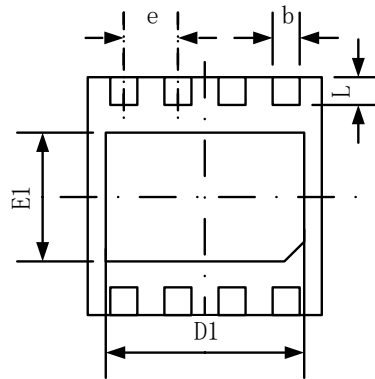

BOTTOM VIEW

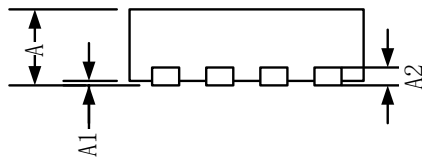

SIDE VIEW

| Symbol | Dimensions In Millimeters | | Dimensions In Inches | |
|--------|---------------------------|-------|----------------------|-------|
| | Min | Max | Min | Max |
| A | 0.700 | 0.800 | 0.028 | 0.031 |
| A1 | 0.000 | 0.050 | 0.000 | 0.002 |
| A2 | 0.203 | | 0.008 | |
| b | 0.300 | 0.400 | 0.012 | 0.016 |
| D | 2.900 | 3.100 | 0.114 | 0.122 |
| D1 | 2.510 | 2.610 | 0.099 | 0.103 |
| E | 2.900 | 3.100 | 0.114 | 0.122 |
| E1 | 1.550 | 1.650 | 0.061 | 0.065 |
| e | 0.650 TYP | | 0.026 TYP | |
| L | 0.350 | 0.450 | 0.014 | 0.018 |