

General Description

The MAX17231 evaluation kit (EV kit) is a fully assembled and tested application circuit board for the MAX17231 high-voltage, dual synchronous step-down controller with preboost. The EV kit is set up to provide 5V and 3.3V from an input voltage ranging from 3.5V to 36V. The preboost circuit maintains the 10V supply rail for input voltages below 10V. Each buck rail can deliver up to 5A load current. Various jumpers are provided to help evaluate features of the MAX17231 IC.

Features

- Dual, Synchronous Step-Down Controllers Operate at 180° Out-of-Phase to Reduce Switching Noise
- Preboost Controller to Maintain Operation with Low Supply Voltage
- 3.5V to 36V Wide Input Supply Range
- Buck Output Voltage: 5V and 3.3V Fixed or Adjustable Between 1V and 10V
- Current-Mode Controllers with Forced-PWM and Skip Modes
- Resistor-Configurable Frequency Between 1MHz and 2.2MHz
- Independent Enable Inputs
- 85% Peak Efficiency at 12V Input in Skip-Mode
- FSYNC Input and Power-Good Output
- Proven 4-Layer 2oz Copper PCB Layout
- Demonstrates 1937mil x 1702mil Solution Size
- Fully Assembled and Tested

EV Kit Contents

- MAX17231EV Kit Board

Ordering Information appears at end of data sheet.

Quick Start

Recommended Equipment

- MAX17231 EV Kit
- 3.5V to 36V, 20A power supply (the power supply should be capable of providing 20A at 3V input)
- Two voltmeters
- Two electronic loads capable of sinking 5A each

Procedure

The EV kit is fully assembled and tested. Follow the steps below to activate the board. **Caution: Do not turn on the power supply until all connections are completed.**

- 1) Verify that all jumpers are in their default configurations according to [Table 1](#).
- 2) Connect the positive and negative terminals of the power supply to the VBATF and PGND banana jacks, respectively.
- 3) Connect the positive terminal of the first electronic load to the VOUT1 banana jack. Connect the ground terminal of the electronic load to the corresponding PGND banana jack.
- 4) Connect the positive terminal of the second electronic load to the VOUT2 banana jack. Connect the ground terminal of the electronic load to the corresponding PGND banana jack.
- 5) Set the power-supply voltage to 14V.
- 6) Turn on the power supply.
- 7) Enable the electronic loads.
- 8) Verify that VOUT1 is approximately 5V.
- 9) Verify that VOUT2 is approximately 3.3V.

Table 1. Default Jumper Settings

JUMPER	DEFAULT SHUNT POSITION	FUNCTION
JU1, JU2	Installed	PGOOD_ pulls up to BIAS when OUT_ is in regulation.
JU3	Installed	Preboost on-indicator enabled.
JU5	1-4	Switches to EXTVCC. Internal regulator disabled.
JU6	1-2	Forced-PWM mode.
JU7, JU8, JU9	1-2	Buck outputs, preboost enabled.

Detailed Description of Hardware

The MAX17231 EV kit, which evaluates the MAX17231 high-voltage, dual synchronous step-down controller with preboost, can supply up to two rails. The EV kit includes two current-mode buck outputs that are fixed to 5V and 3.3V, or configurable from 1V to 10V with external resistor-dividers. The current capability is 5A per rail. Both outputs are current limited and can be controlled independently through their respective enable inputs EN_. The EV kit includes an external preboost, which enables full output functionality during undervoltage events. The EV kit also includes a 5V, 100mA internal linear regulator (BIAS), which powers the internal circuitry of the MAX16930.

Switching Frequency/External Synchronization

The EV kit switching frequency can be adjusted from 1MHz to 2.2MHz by changing the FOSC resistor R75. The EV kit can also be synchronized to an external clock by connecting the external clock signal to the FSYNC test point and AGND. Refer to the *Switching Frequency/External Synchronization* section in the MAX17231 IC data sheet for more details.

Buck Output Monitoring (PGOOD_)

The EV kit provides two power-good output test points (PGOOD1 and PGOOD2) to monitor the status of the two buck outputs (OUT1 and OUT2). Each PGOOD_ goes high (high impedance) when the corresponding regulator output voltage is in regulation. Each PGOOD_ goes low when the corresponding regulator output voltage drops below 15% (typ) or rises above 10% (typ) of its nominal regulated voltage.

To obtain a logic signal, pull up PGOOD_ to BIAS by installing shunts on JU1 and JU2.

Table 2. EXTVCC (JU5)

SHUNT POSITION	EXTVCC PIN	BIAS
1-2	Connected to VOUT2	Switches to EXTVCC. Internal regulator disabled.
1-3	Connected to PGND	Internal regulator enabled to generate BIAS supply.
1-4*	Connected to VOUT1	Switches to EXTVCC. Internal regulator disabled.

*Default configuration.

Table 3. Mode of Operation (JU6)

SHUNT POSITION	FSYNC PIN	MODE
1-2*	Connected to BIAS	Forced-PWM mode
2-3	Connected to AGND	Skip mode

*Default configuration.

EXTVCC Switchover Comparator

The internal linear regulator can be bypassed by connecting an external supply (3V to 5.2V) or the output of one of the buck converters to EXTVCC. BIAS internally switches to EXTVCC and the internal linear regulator turns off. If VEXTVCC drops below $V_{TH,EXTVCC} = 3V(\min)$, the internal regulator enables and switches back to BIAS.

Mode of Operation

The EV kit features jumper JU6 to configure the mode switch-control input. Drive FSYNC high (pins 1-2 of JU6) to enable forced-PWM mode. Drive FSYNC low (pins 2-3 of JU6) to enable skip mode under light loads.

Enable Control

The EV kit features jumpers JU7, JU8, and JU9 to independently control the digital enable inputs of the buck 1 controller, the buck 2 controller, and the boost controller, respectively. Connect the active-high input EN_ to VIN (pins 1-2) to enable the corresponding controller. Connect the EN_ pin to PGND (pins 2-3) to disable the corresponding controller. See [Table 4](#).

Setting the Output Voltage in Buck Converters

To externally adjust the output voltage OUT1 between 1V and 10V, remove R61. Connect a resistive divider from the output OUT1 to FB1 to AGND. Place appropriate resistors in positions R58 and R59 according to the following equation:

$$R58 = R59 \left[\left(\frac{V_{OUT1}}{V_{FB1}} \right) - 1 \right]$$

where $V_{FB1} = 1V$ (typ).

To externally adjust the output voltage OUT2 between 1V and 10V, remove R73. Connect a resistive divider from the output OUT2 to FB2 to AGND. Place appropriate resistors in positions R70 and R71 according to the following equation:

$$R70 = R71 \left[\left(\frac{V_{OUT2}}{V_{FB2}} \right) - 1 \right]$$

where $V_{FB2} = 1V$ (typ).

Preboost

The EV kit includes an asynchronous current-mode preboost with adjustable output. The boost converter output is called VIN since it powers the input supply pin of the device. This preboost can be used independently, but is ideally suited for applications that need to stay fully functional during input voltage dropouts typical for systems that have an input voltage that varies over a wide range and where the input voltage can drop below the output voltage.

Note: The preboost output (V_{IN}) automatically changes its slope compensation when $V_{IN} - V_{BATF}$ is near 5.3V to maintain optimum stability.

To externally adjust the boost output voltage (V_{IN}), place appropriate resistors in positions R78 and R79 according to the following equation:

$$R78 = R79 \left[\left(\frac{V_{VIN}}{V_{FB3}} \right) - 1 \right]$$

where $V_{FB3} = 1.25V$ (typ).

Evaluating the MAX17230 On the MAX17231 EV Kit

The MAX17231 EV kit can be modified to operate the MAX16931. The MAX17230 operates at a switching frequency of 400kHz, which requires a change in the following components:

- 1) Replace U1 with the MAX17230 IC.
- 2) Replace R75 (R_{FOSC}) with 80.6k Ω to achieve 400kHz switching frequency.
- 3) Replace the preboost inductor (L6) with a 2.2 μ H 15A inductor.
- 4) Replace the buck inductors (L4, L5) with a 6.8 μ H 7A inductor.

Contact Technical Support at www.maximintegrated.com/support for any further questions.

Table 4. Enable Control (JU7, JU8, JU9)

SHUNT POSITION	EN_ PIN	CONTROLLER_
1-2*	Connected to VIN	Enabled
2-3	Connected to PGND	Disabled

*Default configuration.

Component Suppliers

SUPPLIER	WEBSITE
Fairchild Semiconductor	www.fairchildsemi.com
Murata Electronics North America, Inc.	www.murata.com
NXP Semiconductors	www.nxp.com
Panasonic Corp.	www.panasonic.com
Stackpole Electronics	www.seielect.com
TDK Corp.	www.component.tdk.com
Taiyo Yuden	www.t-yuden.com
TT Electronics	www.ttelectronics.com
Vishay	www.vishay.com

Note: Indicate that you are using the MAX17231 when contacting these component suppliers.

MAX17231 EV Kit Bill of Materials

REF_DES	QTY	DESCRIPTION
BSTON, FSYNC, PGOOD1, PGOOD2	4	TEST POINT; PIN DIA=0.1IN; TOTAL LENGTH=0.3IN; BOARD HOLE=0.04IN; RED; PHOSPHOR BRONZE WIRE SILVER PLATE FINISH;
C2-C4, C33, C41	5	CAPACITOR; SMT (0603); CERAMIC CHIP; 0.1UF; 50V; TOL=10%; TG=-55 DEGC TO +125 DEGC; TC=X7R;
C5, C48-C51, C53-C55, C74	9	CAPACITOR; SMT (1210); CERAMIC CHIP; 4.7UF; 50V; TOL=10%; TG=-55 DEGC TO +125 DEGC; TC=X7R; AUTO
C34, C35, C42, C43	4	CAPACITOR; SMT (1210); CERAMIC; 47UF; 10V; TOL=10%; MODEL=GRM SERIES; TG=-55 DEGC TO +125 DEGC; TC=X7R
C36, C44	2	CAPACITOR; SMT (0402); CERAMIC CHIP; 4700PF; 50V; TOL=10%; TG=-55 DEGC TO +125 DEGC; TC=X7R-
C37	1	CAPACITOR; SMT (0402); CERAMIC CHIP; 22PF; 50V; TOL=5%; TG=-55 DEGC TO +125 DEGC; TC=C0G
C39	1	CAPACITOR; SMT (1206); CERAMIC CHIP; 6.8UF; 16V; TOL=10%; TG=-55 DEGC TO +125 DEGC; TC=X7R
C40	1	CAPACITOR; SMT (0603); CERAMIC CHIP; 2.2UF; 10V; TOL=10%; TG=-55 DEGC TO +125 DEGC; TC=X7R
C45	1	CAPACITOR; SMT (0402); CERAMIC CHIP; 10PF; 50V; TOL=2%; TG=-55 DEGC TO +125 DEGC; TC=C0G
C46	1	CAPACITOR; SMT (CASE_F); ALUMINUM-ELECTROLYTIC; 150UF; 35V; TOL=20%; TG=-55 DEGC TO +105 DEGC; AUTO
C47	1	CAPACITOR; SMT (CASE_G); ALUMINUM-ELECTROLYTIC; 270UF; 35V; TOL=20%; TG=-55 DEGC TO +105 DEGC; AUTO
C57	1	CAPACITOR; SMT (0603); CERAMIC CHIP; 0.022UF; 50V; TOL=10%; TG=-55 DEGC TO +125 DEGC; TC=X7R
D1, D2	2	DIODE; SCH; SMT (SOD-128); PIV=40V; IF=5A
D7, D12	2	DIODE; SCH; SMT (SOT-23); PIV=30V; IF=0.2A
D16	1	DIODE; SCH; SMT (SOT-1289); PIV=45V; IF=15A
JU1-JU3	3	CONNECTOR; MALE; THROUGH HOLE; BREAKAWAY; STRAIGHT; 2PINS
JU5	1	CONNECTOR; MALE; THROUGH HOLE; BREAKAWAY; STRAIGHT; 4PINS
JU6-JU9	4	CONNECTOR; MALE; THROUGH HOLE; BREAKAWAY; STRAIGHT; 3PINS
L4, L5	2	INDUCTOR; SMT; SHIELDED; 2.2UH; TOL=+-20%; 9A
L6	1	INDUCTOR; SMT; SHIELDED; 0.47UH; TOL=+-20%; 17.5A
Q8-Q11	4	TRAN; N-CHANNEL POWER TRENCH MOSFET; NCH; MLP8-EP; PD-(24W); I-(18A); V-(40V)
Q12	1	TRAN; N-CHANNEL 40-V (D-S) MOSFET; NCH; SO-8; PD-(41.7W); I-(30A); V-(40V)
R1-R3	3	RESISTOR; 0603; 1K OHM; 5%; 200PPM; 0.10W; THICK FILM
R5, R52-R54, R61, R64-R66, R73, R82	10	RESISTOR; 0603; 0 OHM; 0%; JUMPER; 0.1W; THICK FILM
R55, R67	2	RESISTOR; 2010; 0.012 OHM; 1%; 100PPM; 1W; THICK FILM
R62	1	RESISTOR, 0603, 22.1KOHMS, 1%,100PPM, 0.1W, THICK FILM
R63	1	RESISTOR; 0603; 1 OHM; 5%; 200PPM; 0.1W; THICK FILM
R74	1	RESISTOR; 0603; 14K OHM; 1%; 100PPM; 0.1W; THICK FILM

MAX17231 EV Kit Bill of Materials (Continued)

REF_DES	QTY	DESCRIPTION
R75	1	RESISTOR; 0603; 15.4K OHM; 1%; 100PPM; 0.1W; THICK FILM
R76	1	RESISTOR; 0603; 100K; 1%; 100PPM; 0.10W; THICK FILM
R77	1	RESISTOR; 2728; 0.005 OHM; 1%; 25PPM; 4W; METAL FOIL
R78	1	RESISTOR; 0603; 140K OHM; 1%; 100PPM; 0.1W; THICK FILM
R79, R81	2	RESISTOR; 0603; 20K OHM; 1%; 100PPM; 0.1W; THICK FILM
R80	1	RESISTOR; 0603; 133K OHM; 1%; 100PPM; 0.10W; THICK FILM
R95-R97	3	RESISTOR; 0603; 51.1K; 1%; 100PPM; 0.10W; THICK FILM
SU1-SU8	8	TEST POINT; JUMPER; STR; TOTAL LENGTH=0.24IN; BLACK; INSULATION=PBT;PHOSPHOR BRONZE CONTACT=GOLD PLATED
U1	1	EVKIT PART-IC; 2MHZ; 36V; DUAL BUCK WITH PREBOOST AND 20UA QUIESCENT CURRENT; TQFN40-EP
X1	1	CONNECTOR; MALE; PANELMOUNT; BANANA JACK; STRAIGHT; 1PIN
X4	1	CONNECTOR; MALE; PANELMOUNT; BANANA JACK; STRAIGHT; 1PIN
X5, X9, X11	3	CONNECTOR; MALE; PANELMOUNT; BANANA JACK; STRAIGHT; 1PIN
X6	1	TEST POINT; PIN DIA=0.1IN; TOTAL LENGTH=0.3IN; BOARD HOLE=0.04IN; BLACK; PHOSPHOR BRONZE WIRE SILVER PLATE FINISH;
X8	1	CONNECTOR; MALE; PANELMOUNT; BANANA JACK; STRAIGHT; 1PIN
X10	1	CONNECTOR; MALE; PANELMOUNT; BANANA JACK; STRAIGHT; 1PIN
X22	1	CONNECTOR; MALE; PANELMOUNT; BANANA JACK; STRAIGHT; 1PIN
C1, C6-C10, C56, C60, C61	0	PACKAGE OUTLINE 0603 NON-POLAR CAPACITOR
L1	0	PACKAGE OUTLINE 1806 INDUCTOR
VIN, PGND, VBAT, VBATF, VOUT1, VOUT2	0	EVK KIT PARTS; MAXIM PAD; WIRE; NATURAL; SOLID; WEICO WIRE; SOFT DRAWN BUS TYPE-S; 20AWG
R4, R58, R59, R70, R71	0	PACKAGE OUTLINE 0603 RESISTOR
X3, X7	0	EVK KIT PARTS; MAXIM PAD; WIRE; NATURAL; SOLID; WEICO WIRE; SOFT DRAWN BUS TYPE-S; 20AWG
PCB	1	PCB Board:MAX17231 EVALUATION KIT

MAX17231 EV Kit PCB Layout Diagrams (continued)

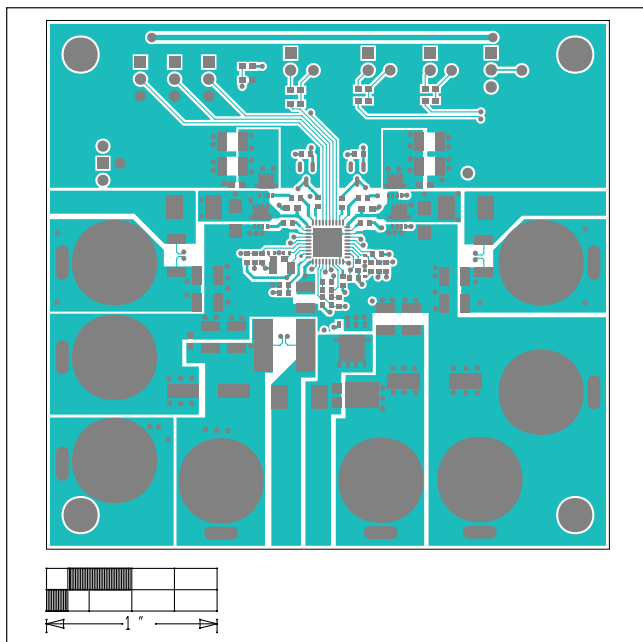

MAX17231 EV Kit—Top

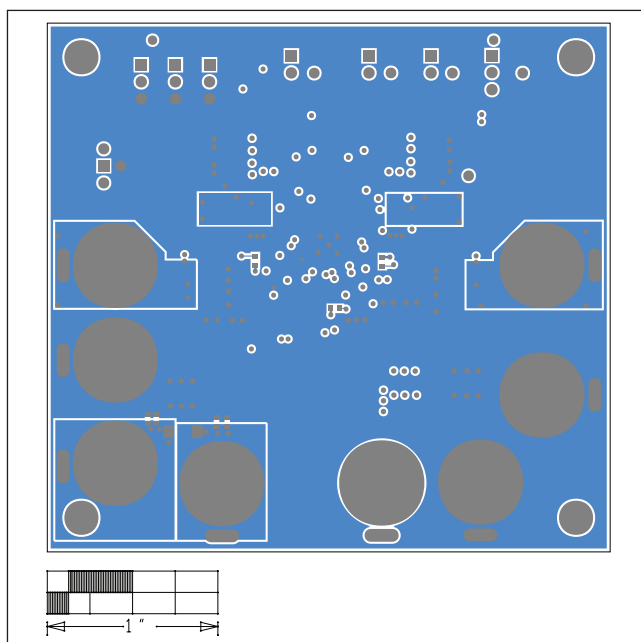

MAX17231 EV Kit—Bottom

MAX17231 EV Kit Schematic

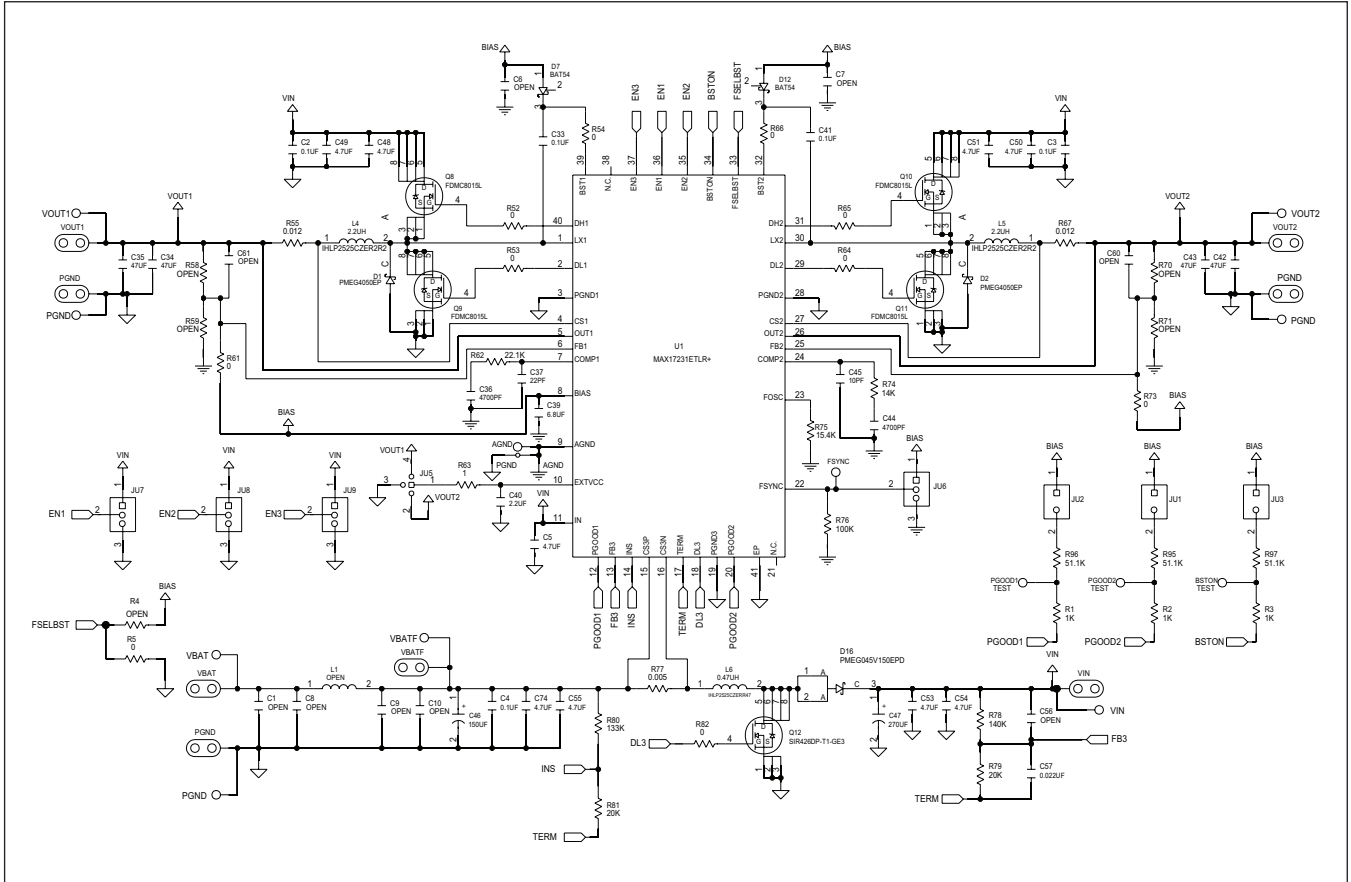

MAX17231 EV Kit Minimal Component Schematic

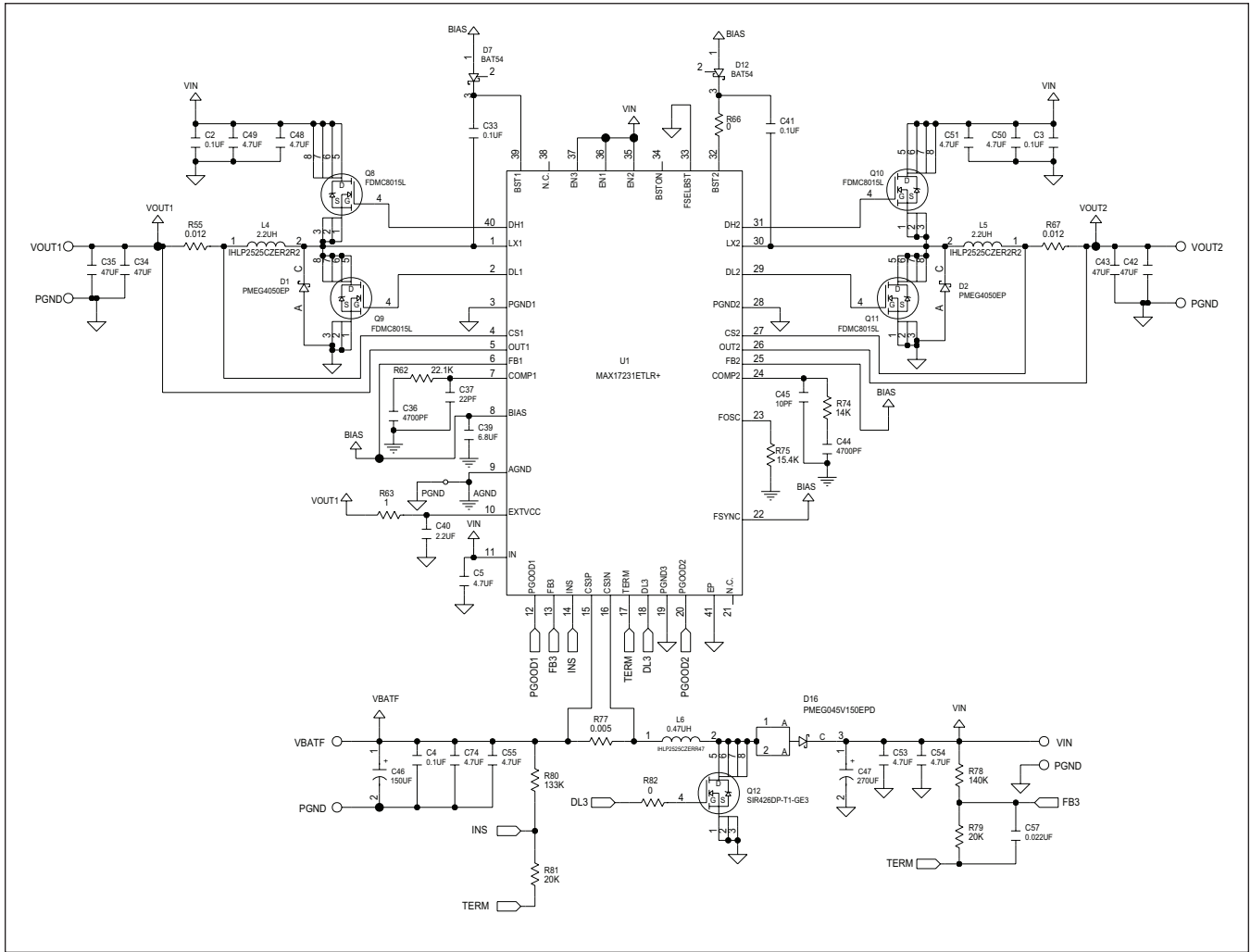

Ordering Information

PART	TYPE
MAX17231EVKIT#	EV Kit

#Denotes RoHS compliant.

Revision History

REVISION NUMBER	REVISION DATE	DESCRIPTION	PAGES CHANGED
0	5/17	Initial release	—

For pricing, delivery, and ordering information, please contact Maxim Direct at 1-888-629-4642, or visit Maxim Integrated's website at www.maximintegrated.com.

Maxim Integrated cannot assume responsibility for use of any circuitry other than circuitry entirely embodied in a Maxim Integrated product. No circuit patent licenses are implied. Maxim Integrated reserves the right to change the circuitry and specifications without notice at any time.