

LOC		DIST		REVISIONS				DATE	APPD
ZONE	LTR	DESCRIPTION	DATE	APPD					
G	14	P	F	B	REV & REDRAWN PER 0720-0040-93	3-17-93	DA P		

METRIC
 DIMENSIONS LISTED IN mm [INCHES]

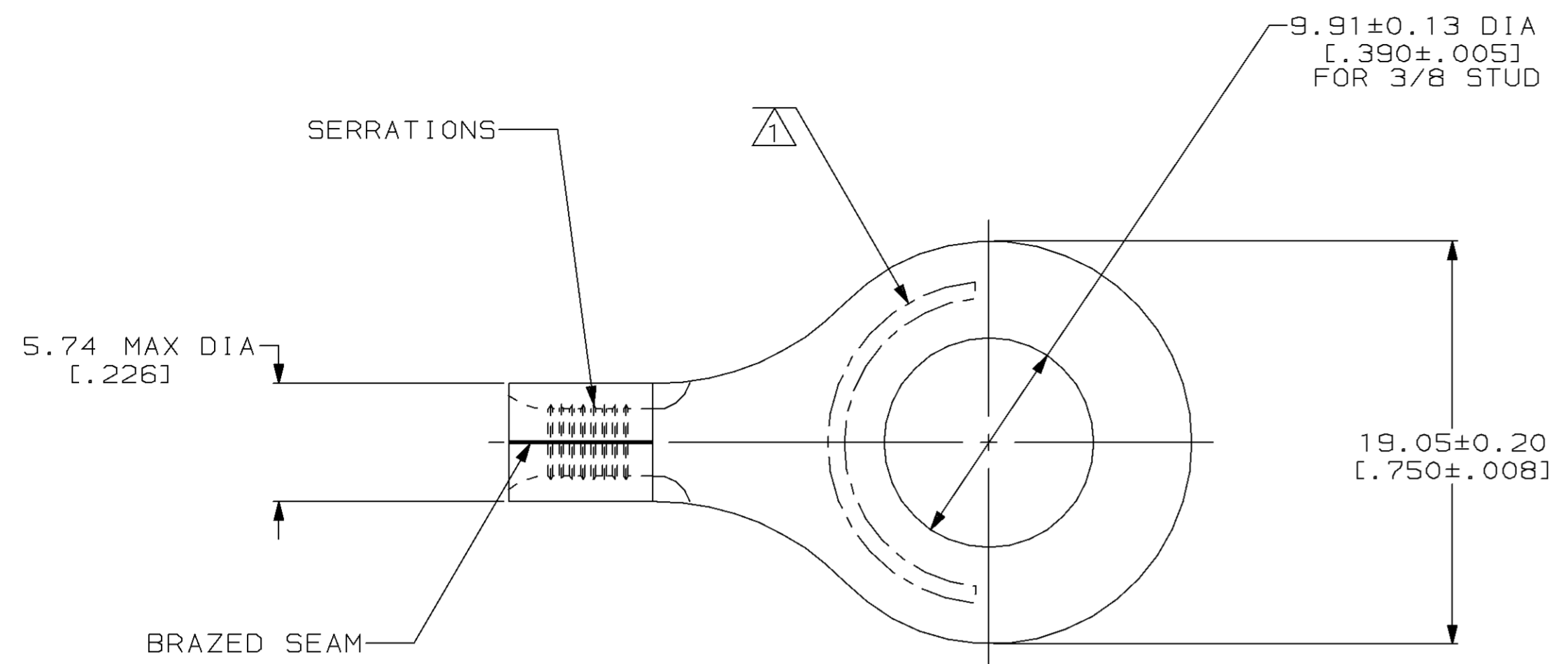

AMP WIRE RANGE	UL E13288 Listed
16-14HD AWG SOLID OR STRANDED	16-14HD AWG STRANDED
SR LR7189 Certified	MILITARY P/N AND CLASS
16-14HD AWG SOLID OR STRANDED	NOT APPLICABLE

① STAMP AMP 16-14HD* APPROX AS SHOWN

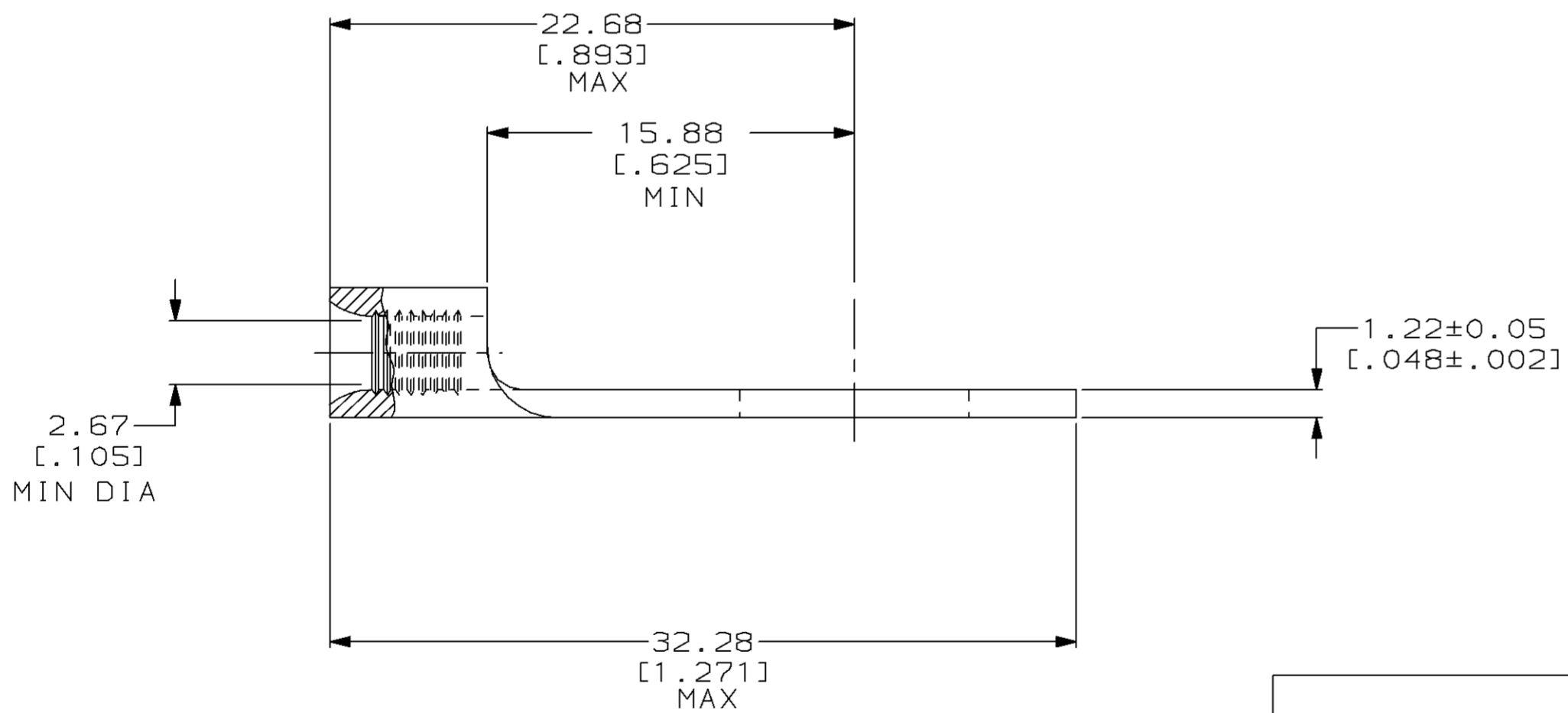

AMP INCORPORATED CUSTOMER SERVICE SYSTEMS		MAX RECOMMENDED OPERATING TEMPERATURE: 170°C MAX	DO NOT SCALE PRINT. UNLESS SPECIFIED DIMENSIONS IN mm [INCHES] TOLERANCES ON: 2 PLC DEC ± - 3 PLC DEC ± - ANGLES ± -	DR 3-17-93 TA BRINKMAN	AMP AMP Incorporated Harrisburg, PA 17105-3608		
FOR ADDITIONAL PRODUCT INFORMATION OR COPIES OF DRAWINGS AND TECHNICAL DOCUMENTS	PRODUCT INFORMATION CENTER 1-800-522-6752	VOLTAGE RATING: NOT APPLICABLE	MATERIAL COPPER PER ASTM B-152 ANNEALED	CHK 3-17-93 DA PATTERSON	NAME TERMINAL, RING TONGUE, HEAVY DUTY, SOLISTRAND™		
FOR APPLICATION TOOLING INFORMATION	TOOLING ASSISTANCE CENTER 1-800-722-1111	WIRE CROSS SECTIONAL AREA RANGE: 1.04-2.62mm ² [2,050-5,180] CIR MILS SOLID OR STRANDED	FINISH TIN PLATE 0.00254 [0.00100] MIN THK PER MIL-T-10727	APPD 3-17-93 DE MILLER	SIZE ③ 00779	CAGE CODE 00779	DRAWING NO ③=327732
FOR ORDER ENTRY	1-800-526-5142	THIS DRAWING IS A CONTROLLED DOCUMENT FOR AMP INCORPORATED. IT IS SUBJECT TO CHANGE AND THE CONTROLLING ENGINEERING ORGANIZATION SHOULD BE CONTACTED FOR THE LATEST REVISION.		APPD 3-17-93 JL MECKLEY	SCALE 4:1		SHEET 1 OF 1