

6 Watt

- 2:1 Input Range
- SIP-8 Plastic Case
- Operating Temperature -40 °C to +90 °C
- Single and Dual Outputs
- 1500 VDC Isolation, 3000 VDC Option
- Remote Control Option
- 3 Year Warranty

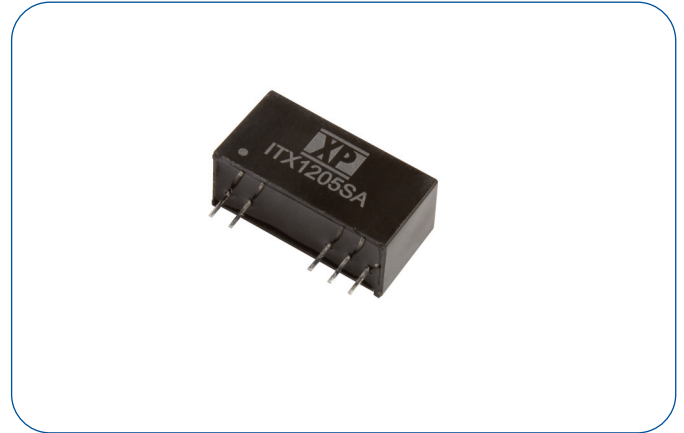

Dimensions:

ITX:
0.86 x 0.44 x 0.36" (21.85 x 11.1 x 9.2 mm)

Models & Ratings

Input Voltage	Output Voltage	Output Current	Input Current ⁽³⁾		Maximum Capacitive Load	Efficiency	Model Number ^(1,2)
			No Load	Full Load			
4.5-9 V	3.3 V	1300 mA	105 mA	1114 mA	6600 µF	77%	ITX0503SA
	5.0 V	1200 mA	105 mA	1481 mA	3300 µF	81%	ITX0505SA
	9.0 V	666 mA	105 mA	1445 mA	2000 µF	83%	ITX0509SA
	12.0 V	500 mA	105 mA	1428 mA	1600 µF	84%	ITX0512SA
	15.0 V	400 mA	105 mA	1428 mA	1400 µF	84%	ITX0515SA
	24.0 V	250 mA	105 mA	1428 mA	680 µF	84%	ITX0524SA
	±5.0 V	±600 mA	105 mA	1481 mA	±2000 µF	81%	ITX0505S
	±12.0 V	±250 mA	105 mA	1428 mA	±900 µF	84%	ITX0512S
9-18 V	3.3 V	1300 mA	55 mA	458 mA	6600 µF	78%	ITX1203SA
	5.0 V	1200 mA	55 mA	602 mA	3300 µF	83%	ITX1205SA
	9.0 V	666 mA	55 mA	595 mA	2000 µF	84%	ITX1209SA
	12.0 V	500 mA	55 mA	588 mA	1600 µF	85%	ITX1212SA
	15.0 V	400 mA	55 mA	588 mA	1400 µF	85%	ITX1215SA
	24.0 V	250 mA	55 mA	595 mA	680 µF	84%	ITX1224SA
	±5.0 V	±600 mA	55 mA	609 mA	±2000 µF	82%	ITX1205S
	±12.0 V	±250 mA	55 mA	595 mA	±900 µF	84%	ITX1212S
18-36 V	3.3 V	1300 mA	30 mA	229 mA	6600 µF	78%	ITX2403SA
	5.0 V	1200 mA	30 mA	301 mA	3300 µF	83%	ITX2405SA
	9.0 V	666 mA	30 mA	294 mA	2000 µF	85%	ITX2409SA
	12.0 V	500 mA	30 mA	294 mA	1600 µF	85%	ITX2412SA
	15.0 V	400 mA	30 mA	290 mA	1400 µF	86%	ITX2415SA
	24.0 V	250 mA	30 mA	294 mA	680 µF	85%	ITX2424SA
	±5.0 V	±600 mA	30 mA	304 mA	±2000 µF	82%	ITX2405S
	±12.0 V	±250 mA	30 mA	297 mA	±900 µF	84%	ITX2412S
36-75 V	3.3 V	1300 mA	15 mA	114 mA	6600 µF	78%	ITX4803SA
	5.0 V	1200 mA	15 mA	152 mA	3300 µF	82%	ITX4805SA
	9.0 V	666 mA	15 mA	148 mA	2000 µF	84%	ITX4809SA
	12.0 V	500 mA	15 mA	147 mA	1600 µF	85%	ITX4812SA
	15.0 V	400 mA	15 mA	145 mA	1400 µF	86%	ITX4815SA
	24.0 V	250 mA	15 mA	148 mA	680 µF	84%	ITX4824SA
	±5.0 V	±600 mA	15 mA	152 mA	±2000 µF	82%	ITX4805S
	±12.0 V	±250 mA	15 mA	147 mA	±900 µF	85%	ITX4812S
±15.0 V	±200 mA	15 mA	147 mA	±660 µF	85%	ITX4815S	

Notes

1. For optional 3000 VDC isolation add suffix '-H' to end of part number e.g. ITX1205SA-H.
2. For optional remote control add suffix '-R' to end of part number e.g. ITX2412S-HR.
3. Input currents measured at nominal input voltage.

Input

Characteristic	Minimum	Typical	Maximum	Units	Notes & Conditions
Input Voltage Range	4.5		9	VDC	5 V nominal
	9		18	VDC	12 V nominal
	18		36	VDC	24 V nominal
	36		75	VDC	48 V nominal
Input Current					See Models and Ratings table
Input Reflected Ripple			30	mA pk-pk	Through 12 μ H inductor and 47 μ F capacitor
Input Surge			15	VDC for 100 ms	5 V models
			25	VDC for 100 ms	12 V models
			50	VDC for 100 ms	24 V models
			100	VDC for 100 ms	48 V models
Input Filter	Capacitor				

Output

Characteristic	Minimum	Typical	Maximum	Units	Notes & Conditions
Output Voltage					See Models and Ratings table
Output Voltage Balance			± 2	%	Dual output models
Initial Set Accuracy			± 1	%	
Minimum Load	0			A	
Line Regulation			± 0.2	%	
Load Regulation			± 1	%	From 0-100%
Cross Regulation			± 5.0	%	Dual output models when one load is varied between 25% and 100% and the other is fixed at 100% load
Start Up Delay		30		ms	
Ripple and Noise			75	mV pk-pk	20 MHz bandwidth, measured using 0.1 μ F capacitor
Transient Response			3	% deviation	Recovery to within 1% in 500 μ s for a 25% load change (5% max. deviation for 3.3 & 5 V models)
Short Circuit Protection					Continuous, with auto recovery
Maximum Capacitive Load					See Models and Ratings table
Temperature Coefficient			0.02	%/°C	
Remote On/Off	Optional by adding suffix -R to model number. Output off: 2-4 mA via 1K Ω resistor into pin 3 with respect to -Vin. Output on: Open or high impedance.				

General

Characteristic	Minimum	Typical	Maximum	Units	Notes & Conditions
Efficiency					See Models and Ratings table
Isolation: Input to Output			1500	VDC	For optional high isolation versions, 3000 VDC input to output add suffix -H to model number
Switching Frequency	0.1		1.5	MHz	Variable
Isolation Resistance	10 ⁹			Ω	
Isolation Capacitance			50	pF	Input to output
Power Density			44	Win ³	
Mean Time Between Failure	770			kHrs	MIL-HDBK-217F, +25 °C GB
Weight		0.011 (4.8)		lb (g)	

Environmental

Characteristic	Minimum	Typical	Maximum	Units	Notes & Conditions
Operating Temperature	-40		+90	°C	Derate from 100% load at +65 °C to 20% load at 90 °C, for all models except 5 V and ± 5 V models: derate from 100% load at 55 °C to 20% load at 90 °C)
Storage Temperature	-55		+125	°C	
Case Temperature			+105	°C	
Operating Humidity			95	% RH	Non-condensing
Cooling					Natural convection

EMC: Emissions

Phenomenon	Standard	Test Level	Notes & Conditions
Conducted	EN55022	Class A	See Application Note
Radiated	EN55022	Class A	

EMC: Immunity

Phenomenon	Standard	Test Level	Criteria	Notes & Conditions
ESD Immunity	EN61000-4-2	3	B	
Radiated Immunity	EN61000-4-3	20 V/m	A	
EFT/Burst	EN61000-4-4	3	B	External input capacitor required, 330 μ F/100 V
Surge	EN61000-4-5	2	B	External input capacitor required, 330 μ F/100 V
Conducted Immunity	EN61000-4-6	3 V rms	A	
Magnetic Fields	EN61000-4-8	1 A/m	A	

Safety Approvals

Safety Agency	Safety Standard	Notes & Conditions
UL	UL60950-1, UL62368-1	
CSA	CAN/CSA C22.2 No.60950-1	
CE	Meets all applicable directives	
UKCA	Meets all applicable legislation	

Mechanical Details

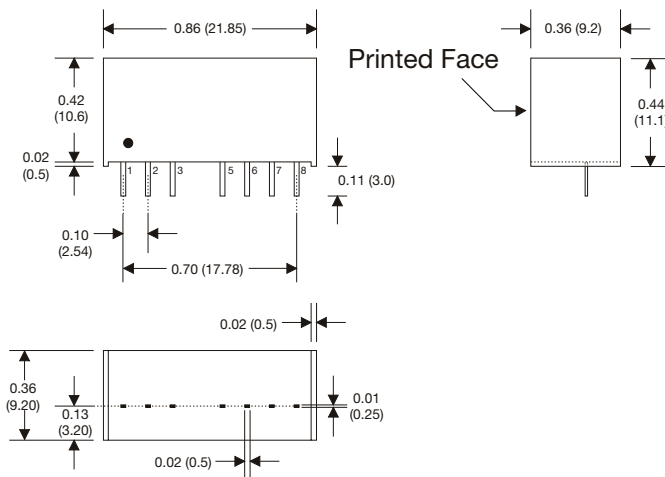

PIN CONNECTIONS		
Pin	Single	Dual
1	-Vin	-Vin
2	+Vin	+Vin
3	N.P.	N.C.
5	N.P.	N.C.
6	+Vout	+Vout
7	-Vout	Common
8	N.C.	-Vout

PIN CONNECTIONS		
Pin	Single -R	Dual -R
1	-Vin	-Vin
2	+Vin	+Vin
3	Remote On/Off	Remote On/Off
5	N.C.	N.C.
6	+Vout	+Vout
7	-Vout	Common
8	N.C.	-Vout

Notes

1. All dimensions are in inches (mm)
2. Weight: 0.011 lbs (4.8 g) typical.
3. Pin diameter: 0.02 \pm 0.002 (0.5 \pm 0.005)
4. Pin pitch and length tolerance: \pm 0.014 (\pm 0.35)
5. Case tolerance: \pm 0.02 (\pm 0.5)

Application Note

EMI Filter

Input filter components (C1,C2,C3,C4,C5, L) are used to help meet conducted emissions requirement for the module.

These components should be mounted as close as possible to the module; and all leads should be minimized to decrease radiated noise.

	C1	C2 & C3*	L	C4 & C5*
ITX05	220 μ F/100V	22 μ F/25 V	10 μ H	220 pF/3 kV
ITX12	-	10 μ F/50 V	10 μ H	220 pF/3 kV
ITX24	-	10 μ F/50 V	10 μ H	220 pF/3 kV
ITX48	-	2.2 μ F/100 V	15 μ H	220 pF/3 kV

* C2, C3, C4 & C5 are multilayer ceramic capacitors.

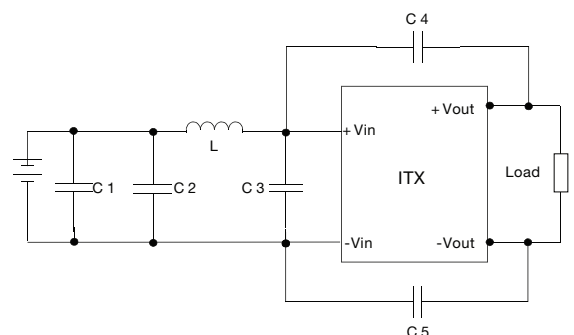

Mouser Electronics

Authorized Distributor

Click to View Pricing, Inventory, Delivery & Lifecycle Information:

[XP Power:](#)

[ITX0515SA](#) [ITX0512S](#) [ITX1209SA](#) [ITX0505SA](#) [ITX4809SA](#) [ITX1215S](#) [ITX0503SA](#) [ITX0505S](#) [ITX0509SA](#)
[ITX4805S](#) [ITX2415SA](#) [ITX2424SA](#) [ITX4812SA](#) [ITX1215SA](#) [ITX2405S](#) [ITX4815S](#) [ITX4803SA](#) [ITX2409SA](#)
[ITX2415S](#) [ITX4805SA](#) [ITX0515S](#) [ITX2412SA](#) [ITX1203SA](#) [ITX1205S](#) [ITX2412S](#) [ITX1212S](#) [ITX4815SA](#) [ITX1205SA](#)
[ITX0524SA](#) [ITX4812S](#) [ITX1212SA](#) [ITX0512SA](#) [ITX2405SA](#) [ITX1224SA](#) [ITX4824SA](#) [ITX2403SA](#)