



Buffers or feet in black Plioprene

- 50 to + 125°C

type	article number	pack
------	----------------	------

Buffers

12-1086 TPE	0146 0010 010	100
12-1310 TPE	0146 0020 010	100

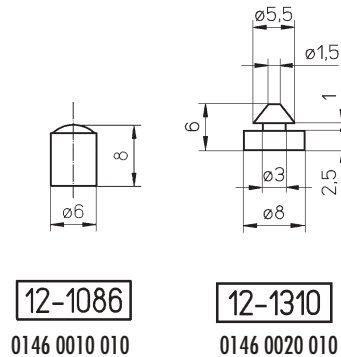

Special grommet in black Plioprene

- 50 to + 125°C

type	article number	pack
------	----------------	------

Special grommet

12-1017 TPE	0146 0310 010	100
12-1431 TPE	0146 0330 010	100

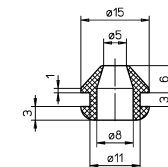
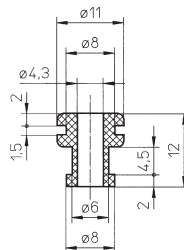

Special grommet

12-1428 TPE	0146 0401 010	100
-------------	---------------	-----

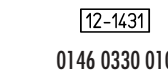
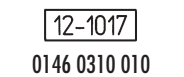

12-1431
0146 0330 010

Special oval grommet

DO 19/27/33/3 TPE	0144 0351 010	100
-------------------	---------------	-----

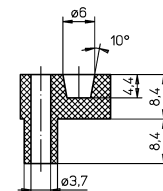
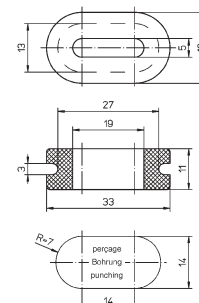
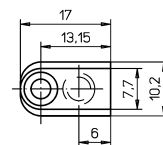

12-1428
0146 0401 010

DO 19/27/33/3 TPE
0144 0351 010

Bushes in Plioprene very flexible, black

- 40 to + 70°C

type	article number	pack
------	----------------	------

Wire protector grommets

12-387 TPE	0146 0110 010	100
12-407 TPE	0146 0120 010	100

These bushes can be easily applied with our sleeve expanders KX1 and KX2. (see page D1/1).

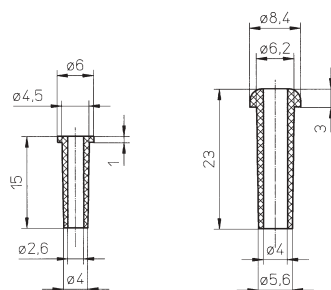

RS 136-7893
12-387
0146 0110 010

RS 136-7900
12-407
0146 0120 010



		Pages du catalogue Catalogue pages Katalogseite	Densité Density Dichte	Sh A	Retrait longitudinal Längsschrumpfung longitudinal shrink	Point de fusion Schmelzpunkt Melting point	Température d'utilisation Einsatztemperatur Operating temp. range	Temp. de rétreint Schrumpftemperatur Shrink temp.	Résistance à la rupture Zugfestigkeit tensile strength at break	Allongement à la rupture Reißeohmung Ultimate elongation	Résist. à basse temp. Kältebeständigkeit Low temper. resistance
			g/cm ³	Sh A	%	°C	°C	°C	MPa	%	°C
HELAVIA	Qual. 3490/3435	A1/1 A2/1		40 ±5			≤ +90		> 8	600	-30
SILAVIA	Qual. 2412	A1/3 A2/2		40 ±5			≤ +200		> 7	600	-80
PLIO-SUPER	Qual. 9923	A3/1 A3/2	1,30	90 ±3			≤ +90		24	300	≥ -20
PLIO-HT	Qual. 9861	A3/5-6	1,30	80 ±5			+105 continuous		20	300	-40 (selon norme ASTM)
PLIO-BT	Qual. 9863	A3/5-6	1,22	75 ±5			≤ +70		> 15	400	-55 aux chocs
PLIO INDUS.	Qual. 9832	A3/7	1,23	85 ±5			≤ +60		> 22,5	350	-20
PLIO-R & R-VJ	Qual. 9901	A4/1	1,3	97 ±3	20 to 30		-20 to +90	+120	20	250	
PLIOFINE	SAM	A4/4			≤ 15			+90/100	> 12	> 200	
	B	A4/7	≤ 1,0		≤ -10			115	20	≥ 200	
	B-EX	A4/9	≤ 1,35		≤ -5			+90	15	≥ 300	
	BX-VJ	A4/11	≤ 1,35					≤ -10%	12,7		
AD-UL3	A4/12	≤ 1,35			≤ +5-10			12	≥ 300		
PLIOSPIRE	Qual. PVC 9921	A5	1,30			+100	-15 to +80		25	300	
	Qual. PTFE		2,20			+325	-200 to +260		20	300	
	Qual. PA 6 BK (010)		1,08			+215	-40 to +120		35	240	
	Qual. PP BK (010)		0,92			+160	-40 to +90		30	500	
	Qual. PE NL (018)		0,90			+112	-50 to +85		12	550	
	Qual. PE BK (010)		0,95			+112	-50 to +85		12	550	
Qual. PE WH (001)	0,97			+112	-50 to +75		12	400			
PLIOSIL	PET	A6	1,38			260	-50 to +130 +220 peak		25	28	
ELECTROFLEX	normal BK (010)	A7/1					-20 to +60		2 to 7,5	85 to 100	
	calor BU (002)						-10 to +90		2 to 7,5	85 to 100	
	oil GH (003)						-20 to +60		11,8	285	
POLYFLEX	PA 6	A7/3				continuous -40 to +120 +150 peak		40-70			
HELAVIA	Polychloroprène Nitrile EPDM	A20		40 to 60			≤ +120		> 6	> 500	≥ -30
PLIOPRENE	TPE	A21	1,0	60 ±5			-50 to +125		> 4,5	> 300	
	TPE extra flexible		0,9	40-45			-40 to +70		8	600	
PLIO	PVC 9542	A22/1.5		60 ±5			≤ +70		10	> 400	-30
	PVC 9641	A22/10&11	1,2	70 ±5			≤ +75		13	350	-25
DM	PA 6	A22/20	1,13				+70 continuous +120 peak		50	45	-20
PLIO	PA6.6 PE - PP	A22/6	1,14				-40 to +110 +180 peak		65	300	-40
	PE - PP	A22/30	0,90				-40 to +85 +120 peak		28	12	
PLIOBORD	PE standard	A23/1	0,92				-50 to +85		> 12	> 550	-50
	PE non flammable		0,97				-50 to +75		> 10	> 600	
A 720	A 720	A23/2-3					+105 continuous	+130			-55
SI-303	Silicone	A23/2-3	1,17				-70 to +250			> 400	
PLIOPLAST	PLIOPLAST 15	A23/4							> 2,8	> 150	
	PLIOPLAST 18							> 3,5	> 250		
	PLIOPLAST 25						-18 to +80		> 5,4	> 175	



		Pages du catalogue Catalogue pages Katalogseite	Résistivité transversale Durchgangswiderstand Volume resistivity	Constante diélectrique Dielektrischer Faktor Dielectric constant	Rigidité diélectrique Durchschlagfestigkeit Dielectric strenght	tenue à la flamme Brandverhalten Flame resistance	Corrosivité Korrosion Corrosion	Absorption d'eau Wasseraufnahme Water Absorption	Indice d'oxygène Sauerstoffindex Limiting oxygen index (LOI)
			Ohm x cm		kV/mm			%	%
HELAVIA	Qual. 3490/3437	A1/1 A2/1	> 4 x 10 ⁹		> 13	UL 94-V0/M3			28
SILAVIA	Qual. 2412	A1/3 A2/2	10 ¹⁵		18				
PLIO-SUPER	Qual. 9923	A3/1 A3/2	to 20°C : 3x10 ¹²		20	UL94-V2			
PLIO-HT	Qual. 9861	A3/5-6			> 20	UL94-V0			
PLIO-BT	Qual. 9863	A3/5-6							
PLIO INDUS.	Qual. 9832	A3/7	to 20°C : 1x10 ¹³		> 20				
PLIO-R & R-VJ	Qual. 9901	A4/1	10 ¹²		20	UL94-V0		0,2	
PLIOFINE	SAM	A4/4	> 10 ¹⁴		> 20	VW-UL 224 self-extinguishing except transparent		≤ 0,2	
	B	A4/7	10 ¹⁵		25		≤ 0,5		
	B-EX	A4/9	10 ¹⁴		20		≤ 0,5		
	BX-VJ	A4/11	10 ¹⁴		20		≤ 0,5		
	AD-UL3	A4/12	10 ¹⁰		16		≤ 1,0		
PLIOSPIRE	Qual. PVC 9921	A5		4	20	UL94-V0 HB		0	0,1
	Qual. PTFE			2,0	50			2	
	Qual. PA 6 BK (010)			3,7	16		< 0,1		
	Qual. PP BK (010)			2,5	> 25		< 0,1		
	Qual. PE NL (018)			2,2	> 25		< 0,1		
	Qual. PE BK (010)			2,2	> 25	UL94-V2	< 0,1		
Qual. PE WH (001)		2,2	> 25		< 0,1				
PLIOSIL	PET	A6				UL94-V2			27,5
ELECTROFLEX	normal BK (010) calor BU (002) oil GH (003)	A7/1			4 4 4	UL94-V0 UL94-V0			
POLVFLEX	PA 6	A7/3	10 ¹²						
HELAVIA	Polychloroprène Nitrile EPDM	A20	> 4x10 ⁸		> 13				
PLIOPRENE	PLIOPRENE TPE	A21	9 x 10 ¹⁴		35				
	PLIOPRENE TPE extra souple		10 ¹⁴		30				
PLIO	PVC 9542	A22/1.5	10 ¹³		> 20	UL94-HB			
	PVC 9641	A22/10 & 11							
DM	PA 6	A22/20	10 ¹³	3,2	50	UL94-V2		2,5	
PLIO	PA6.6 PE - PP	A22/6	10 ¹⁴		26	UL94-V2		2,5	
	PE - PP	A22/30	10 ¹⁶		> 20			< 0,1	
PLIOBORD	PE standard	A23/1	10 ¹⁷	2,2	60	-		< 0,1	
	PE non flammable		10 ¹⁷	2,2	60	UL94-V2	< 0,1		
A 720	A 720	A23/2-3			30		Nulle T° lim. util.		
SI-303	Silicone	A23/2-3	10 ¹⁵	2,9	16				
PLIOPLAST	PLIOPLAST 15	A23/4				self-extinguishing	1		
	PLIOPLAST 18		1						
	PLIOPLAST 25		1						