



PRODUCT NUMBER: 2517-2-01-50-00-00-07-0

www.mill-max.com
DATA SHEET

2517-X-01-XX-00-00-07-0
Swage mount in .064 hole

Basic Part Number	Board Thickness	Length V
25XX-1	.031	.062
25XX-2	.062	.094
25XX-3	.094	.125
25XX-4	.125	.156

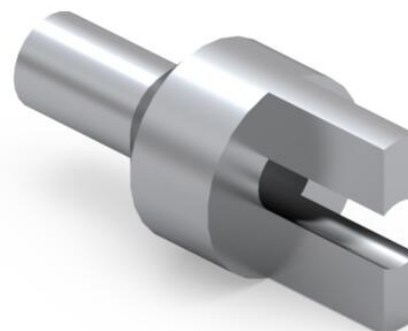

2517-2-01-50-00-00-07-0 SPECIFICATIONS

General Info	
Description¹:	Slotted Terminal Pin
Mounting Feature:	Swage Mount
Mounting Hole:	.064" (1,626mm)
Packaging:	Packaged in Bulk
RoHS:	No
Product Lifecycle²:	Active

Materials	
Shell	
Material	Brass Alloy
Plating⁴:	(60/40 Tin/Lead)
Shell	300 - 500 μ" Electro-Solder

Technical Specs	
Operating Temperature Range⁵:	- 55/+125° C
Current Rating⁶:	Application Specific

NOTES:

1. Standard Tolerances:
Lengths +/- .005" (0,13)
Diameters: +/- .002" (0,051)
Angles: +/- 2°
2. Part is Active and in Production, No Scheduled Obsolescence
3. Brass Alloy 360 per ASTM B 16, or 385 per ASTM B455
4. ELECTRO-SOLDER (60/40) per ASTM B 579, SC2, Bright finish; NICKEL per ASTM B 689, Type 2 (Bright)
5. Per IEC 60512-11-(4,-9,-10,-12)
6. Current rating is typically a measured function of the female socket/connector. The amount of current a solid, male, brass pin can tolerate is a direct relation of the heat displaced based on current and the ability of neighboring components to handle displaced heat.

ADDITIONAL NOTES AND SPECIFICATIONS

In the interest of improved design, quality and performance , Mill-Max reserves the right to make changes in its specifications without prior notice. Specifications and tolerances are provided wherever possible. The tolerance on dimensions of critical to function features is typically held tighter than the stated standard tolerances, such as press-fits, holes and lengths affecting the coplanarity of SMT products. Due to the wide variety of interconnects Mill-Max offers, the specific tolerances vary from product to product. If you need information regarding the tolerance of a particular part, please contact Technical Services.

RELATED LINKS AND DOCUMENTS

Engineering Notebook: (<https://www.mill-max.com/engineering-notebooks/introduction-to-swage-assembly>)

Environmental Compliance: (<https://www.mill-max.com/rohs>)