

CW-RCS Series WiFi 6/6E/7 Right-Angle Whip Antenna

The ANT-W63-CW-RCS is a compact monopole whip antenna designed for WiFi 6/WiFi 6E/WiFi 7 applications in the 2.4 GHz, 5 GHz and 6 GHz bands.

The ANT-W63-CW-RCS is a right-angle whip antenna with a length of only 54 mm and may be used with metallic and non-metallic enclosures. The right-angle rotating design of the ANT-W63-CW-RCS antenna allows for the antenna to be positioned for optimum performance.

The antenna connects via an SMA plug (male pin) or RP-SMA plug (female socket) connector.



ANT-W63-CW-RCS-SMA shown

Features

- Performance at 2.4 GHz to 2.5 GHz
 - VSWR: ≤ 2.2
 - Peak Gain: 7.7 dBi
 - Efficiency: 42%
- Performance at 5.925 GHz to 7.125 GHz
 - VSWR: ≤ 2.7
 - Peak Gain: 6.0 dBi
 - Efficiency: 71%
- Compact size
 - 54.0 mm x \varnothing 9.4 mm
- Rotating base allows for optimal positioning
- SMA plug (male pin) or RP-SMA plug (female socket)

Applications

- WiFi/WLAN coverage
 - WiFi 7 (802.11be)
 - WiFi 6E (802.11ax)
 - WiFi 6 (802.11ax)
 - WiFi 5 (802.11ac)
 - WiFi 4 (802.11n)
 - 802.11b/g
- 2.4 GHz ISM applications
 - Bluetooth®
 - ZigBee®
- U-NII bands 1-8
- Internet of Things (IoT) devices
- Smart Home networking
- Sensing and remote monitoring

Ordering Information

Part Number	Description
ANT-W63-CW-RCS-SMA	WiFi 6/WiFi 6E/WiFi 7 right-angle whip antenna with SMA plug (male pin)
ANT-W63-CW-RCS-RPS	WiFi 6/WiFi 6E/WiFi 7 right-angle whip antenna with RP-SMA plug (female socket)

Available from Linx Technologies and select distributors and representatives.

Table 1. Electrical Specifications

Parameter	ISM/WiFi	WiFi/U-NII 1-3	WiFi 6E/U-NI 4-8
Frequency Range	2400 MHz to 2485 MHz	5150 MHz to 5850 MHz	5925 MHz to 7125 MHz
VSWR (max.)	2.2	2.2	2.7
Peak Gain (dBi)	7.7	5.4	6.0
Average Gain (dBi)	-4.4	-1.6	-1.9
Efficiency (%)	42%	72%	71%
Impedance	50 Ω		
Wavelength	1/4-wave		
Electrical Type	Monopole		
Radiation	Omnidirectional		
Polarization	Linear		
Max Power	5 W		

Electrical specifications and plots measured in free space.

Table 2. Mechanical Specifications

Parameter	Value
Connection	SMA plug (male pin), RP-SMA plug (female socket)
Dimensions	54.0 mm x Ø9.4 mm (2.13 in x Ø0.37 in)
Weight	8.4 g (0.30 oz)
Operating Temp. Range	-20 °C to +85 °C

Product Dimensions

Figure 1 provides dimensions for the ANT-W63-CW-RCS-ccc series antenna.

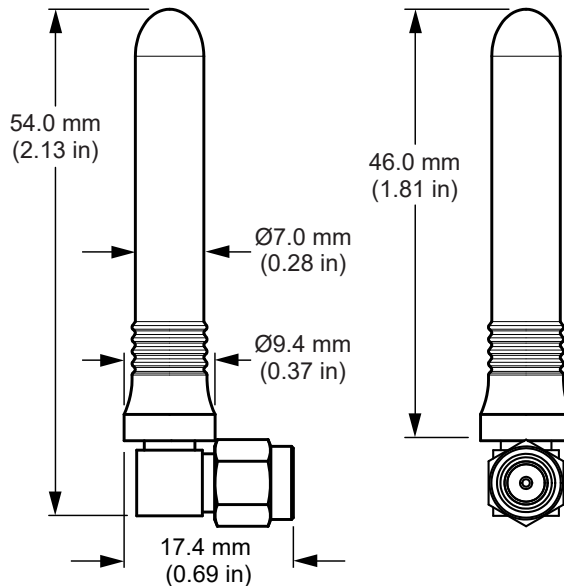

Figure 1. ANT-W63-CW-RCS-ccc Antenna Dimensions

Packaging Information

The ANT-W63-CW-RCS series antenna is individually packaged in a sealed plastic bag in quantities of 100 pcs. Bags are packaged in cartons. Distribution channels may offer alternative packaging options.

Antenna Orientation

The ANT-W63-CW-RCS-ccc antenna is characterized in two antenna orientations as shown in Figure 2. The antenna in a free space orientation characterizes use of an antenna attached to an enclosure-mounted connector which is connected by cable to a printed circuit board. Characterization at the edge of the ground plane (102 mm x 102 mm) provides insight into antenna performance when attached to a connector on a metal enclosure. The two orientations represent the most common end-product use case.

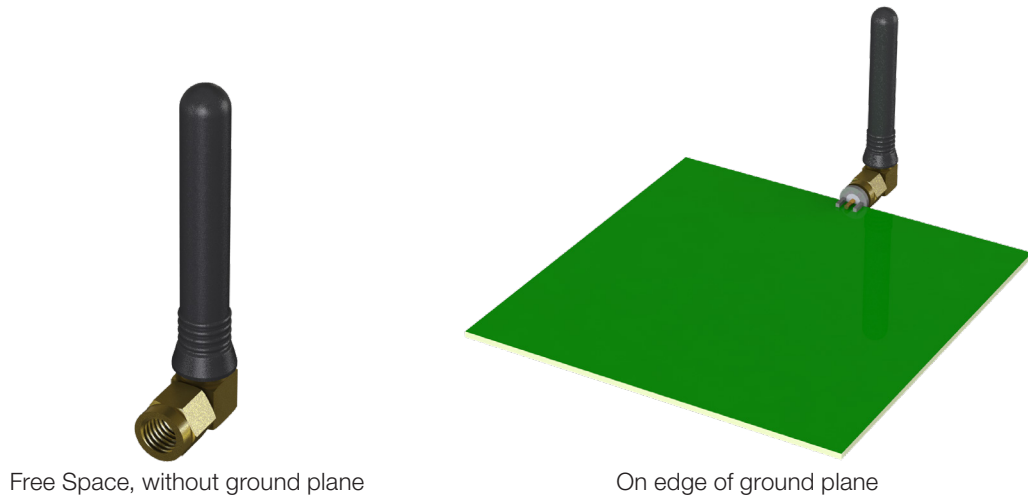

Figure 2. ANT-W63-CW-RCS-ccc Test Orientation

Free Space, No Ground Plane

The charts on the following pages represent data taken with the antenna in Free Space, as shown in Figure 3.



Figure 3. ANT-W63-CW-RCS-ccc, No Ground Plane (Free Space)

VSWR

Figure 4 provides the voltage standing wave ratio (VSWR) across the antenna bandwidth. VSWR describes the power reflected from the antenna back to the radio. A lower VSWR value indicates better antenna performance at a given frequency. Reflected power is also shown on the right-side vertical axis as a gauge of the percentage of transmitter power reflected back from the antenna.

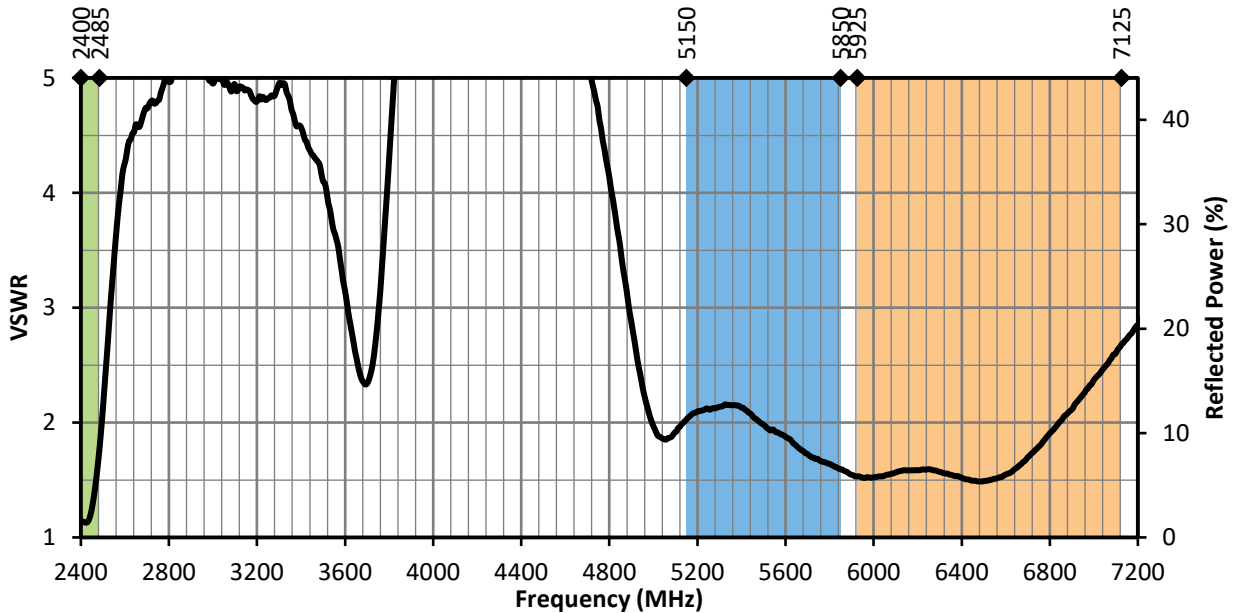

Figure 4. ANT-W63-CW-RCS-ccc Antenna VSWR, Free Space

Return Loss

Return loss (Figure 5), represents the loss in power at the antenna due to reflected signals. Like VSWR, a lower return loss value indicates better antenna performance at a given frequency.

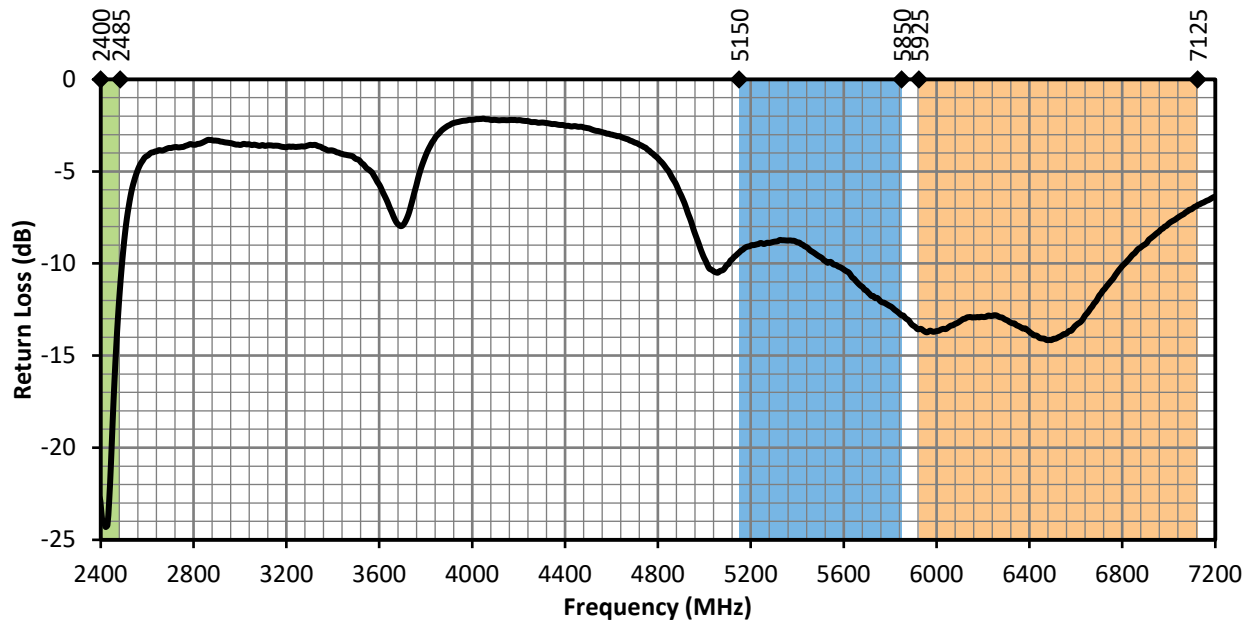

Figure 5. ANT-W63-CW-RCS-ccc Return Loss, Free Space

Peak Gain

The peak gain across the antenna bandwidth is shown in Figure 6. Peak gain represents the maximum antenna input power concentration across 3-dimensional space, and therefore peak performance at a given frequency, but does not consider any directionality in the gain pattern.

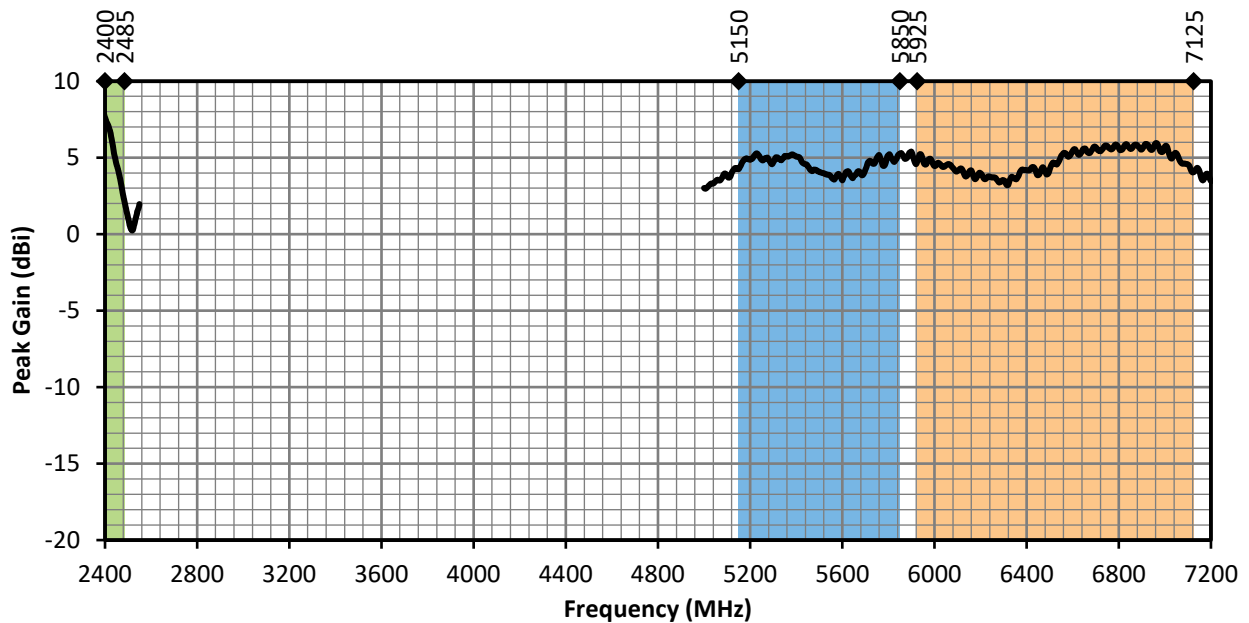

Figure 6. ANT-W63-CW-RCS-ccc Peak Gain, Free Space

Average Gain

Average gain (Figure 7), is the average of all antenna gain in 3-dimensional space at each frequency, providing an indication of overall performance without expressing antenna directionality.

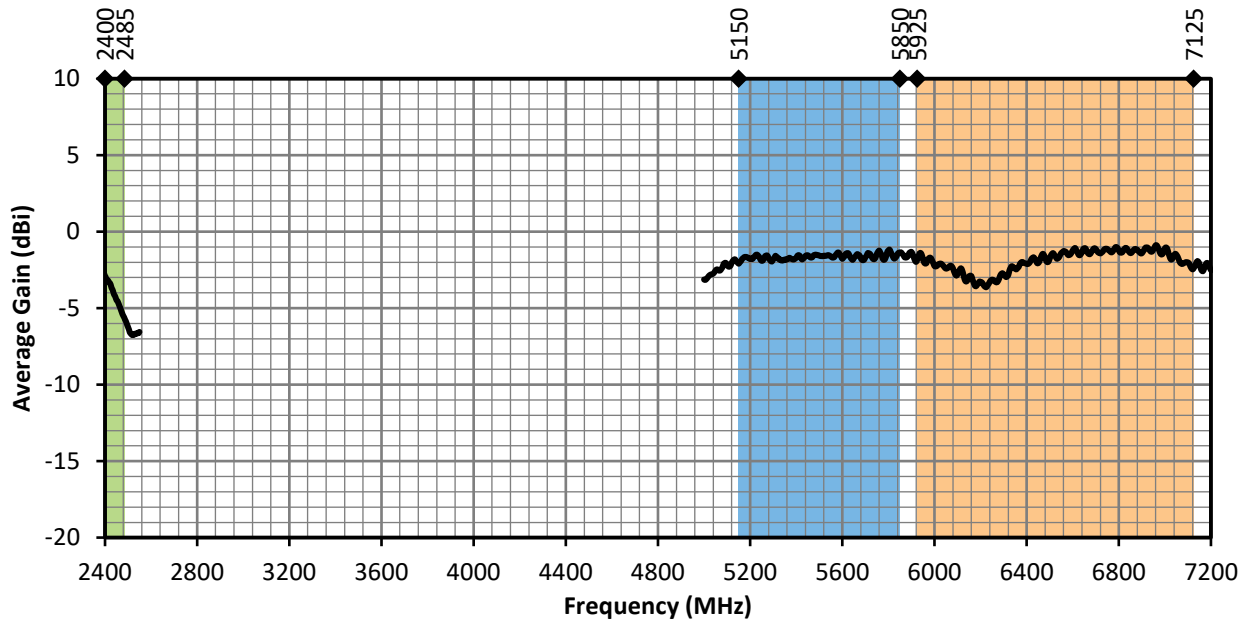

Figure 7. ANT-W63-CW-RCS-ccc Antenna Average Gain, Free Space

Radiation Efficiency

Radiation efficiency (Figure 8), shows the ratio of power delivered to the antenna relative to the power radiated at the antenna, expressed as a percentage, where a higher percentage indicates better performance at a given frequency.

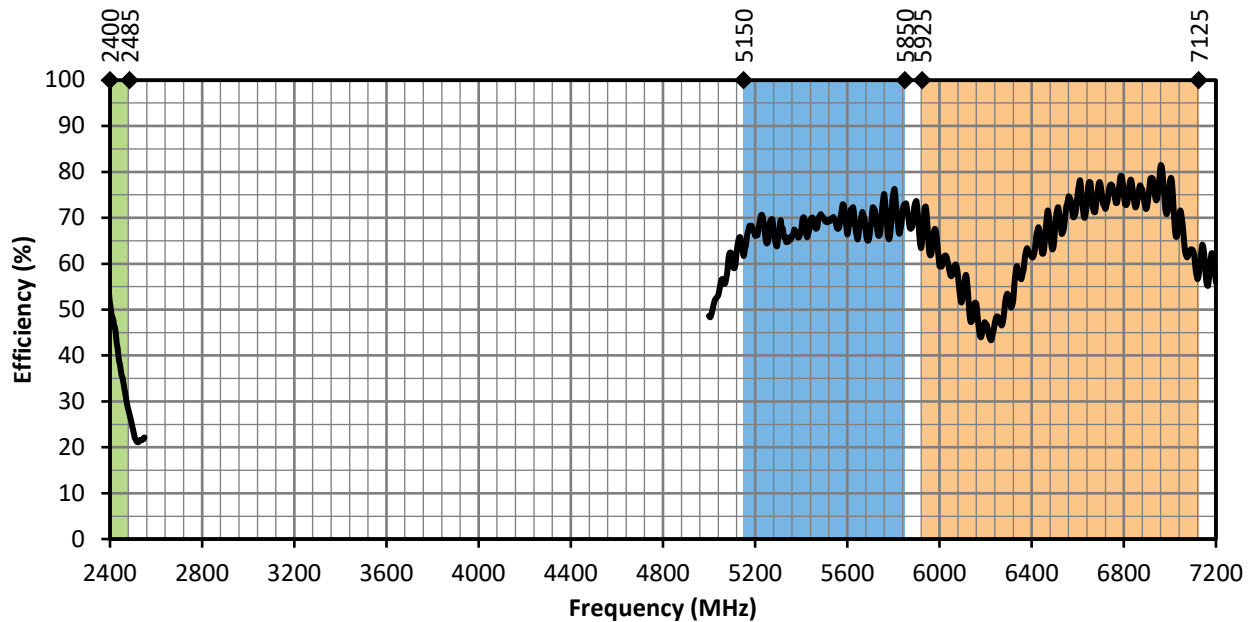

Figure 8. ANT-W63-CW-RCS-ccc Antenna Radiation Efficiency, Free Space

Radiation Patterns

Radiation patterns provide information about the directionality and 3-dimensional gain performance of the antenna by plotting gain at specific frequencies in three orthogonal planes. Antenna radiation patterns are shown in Figure 9 using polar plots covering 360 degrees. The antenna graphic at the top of the page provides reference to the plane of the column of plots below it. Note: when viewed with typical PDF viewing software, zooming into radiation patterns is possible to reveal fine detail.

Radiation Patterns - Free Space



2400 MHz to 2485 MHz (2450 MHz)

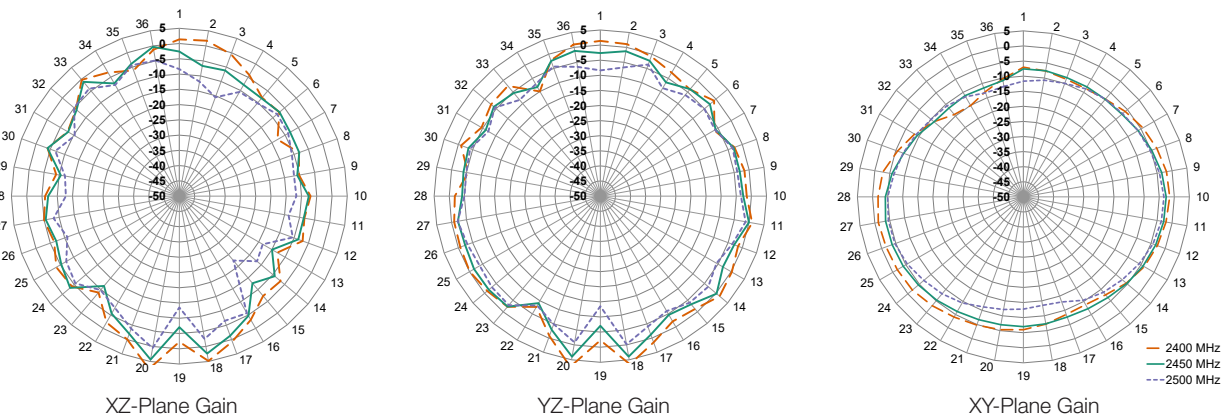

5150 MHz to 5850 MHz (5500 MHz)

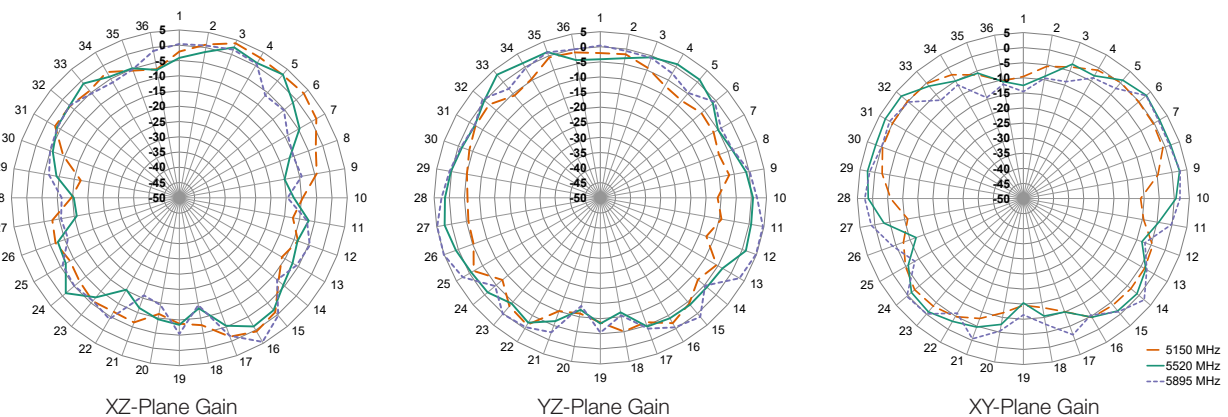

Radiation Patterns - Free Space

5925 MHz to 7125 MHz (6500 MHz)

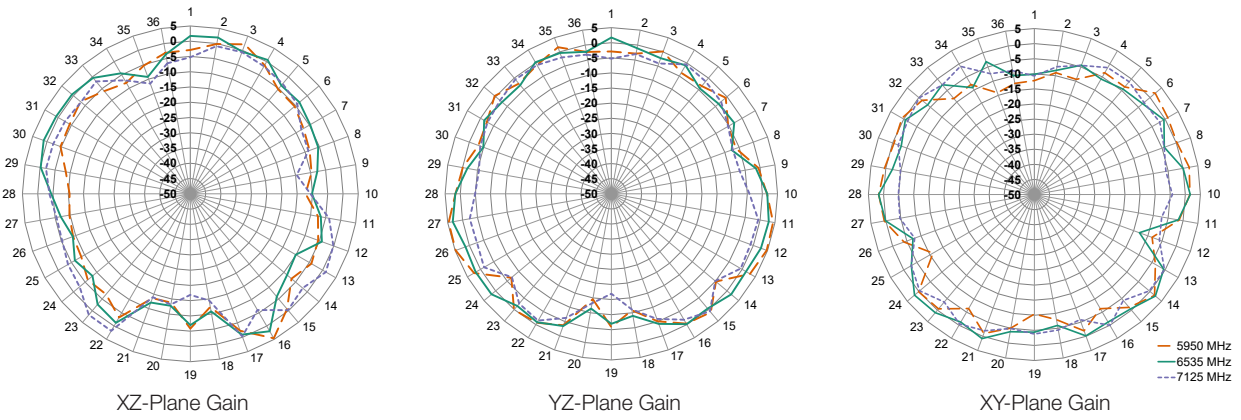

Figure 9. ANT-W63-CW-RCS-ccc Radiation Patterns, Free Space

Edge of Ground Plane

The charts on the following pages represent data taken with the antenna oriented at the edge of the ground plane, as shown in Figure 10.

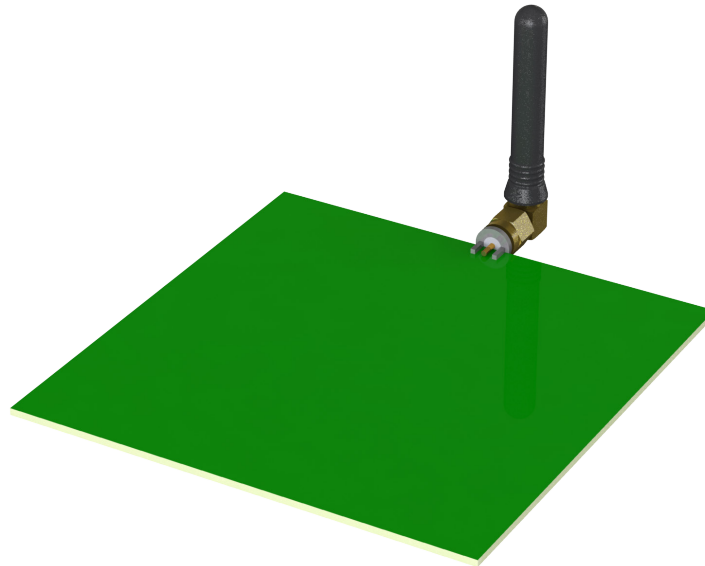

Figure 10. ANT-W63-CW-RCS-ccc on Edge of Ground Plane

VSWR

Figure 11 provides the voltage standing wave ratio (VSWR) across the antenna bandwidth. VSWR describes the power reflected from the antenna back to the radio. A lower VSWR value indicates better antenna performance at a given frequency. Reflected power is also shown on the right-side vertical axis as a gauge of the percentage of transmitter power reflected back from the antenna.

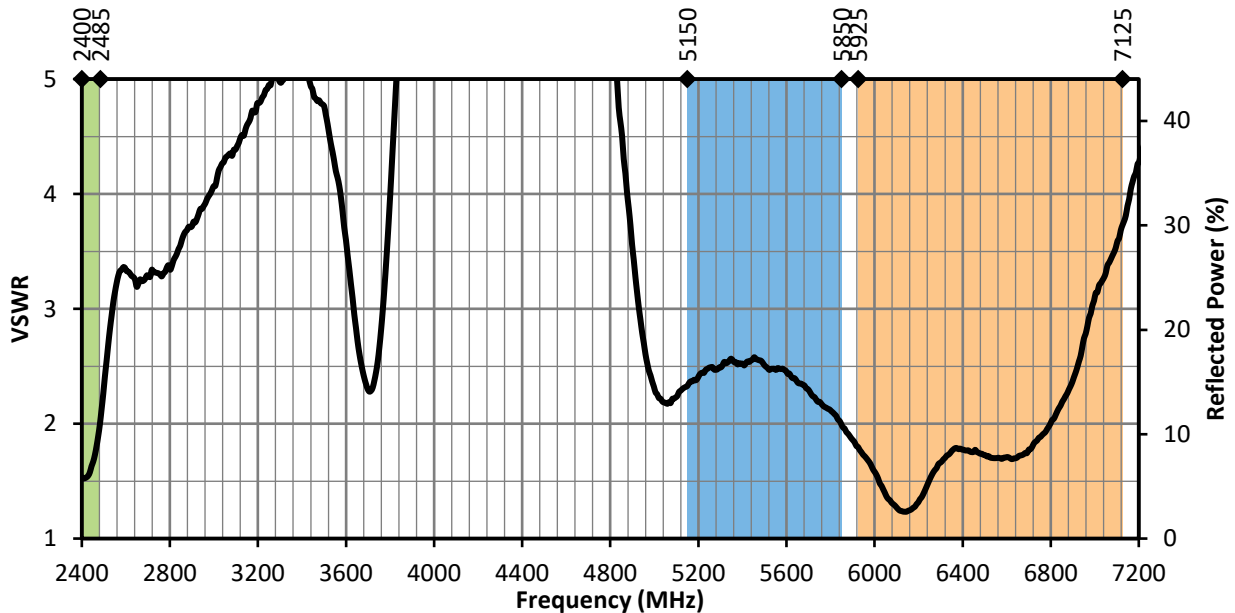

Figure 11. ANT-W63-CW-RCS-ccc VSWR, on Edge of Ground Plane

Return Loss

Return loss (Figure 12), represents the loss in power at the antenna due to reflected signals. Like VSWR, a lower return loss value indicates better antenna performance at a given frequency.

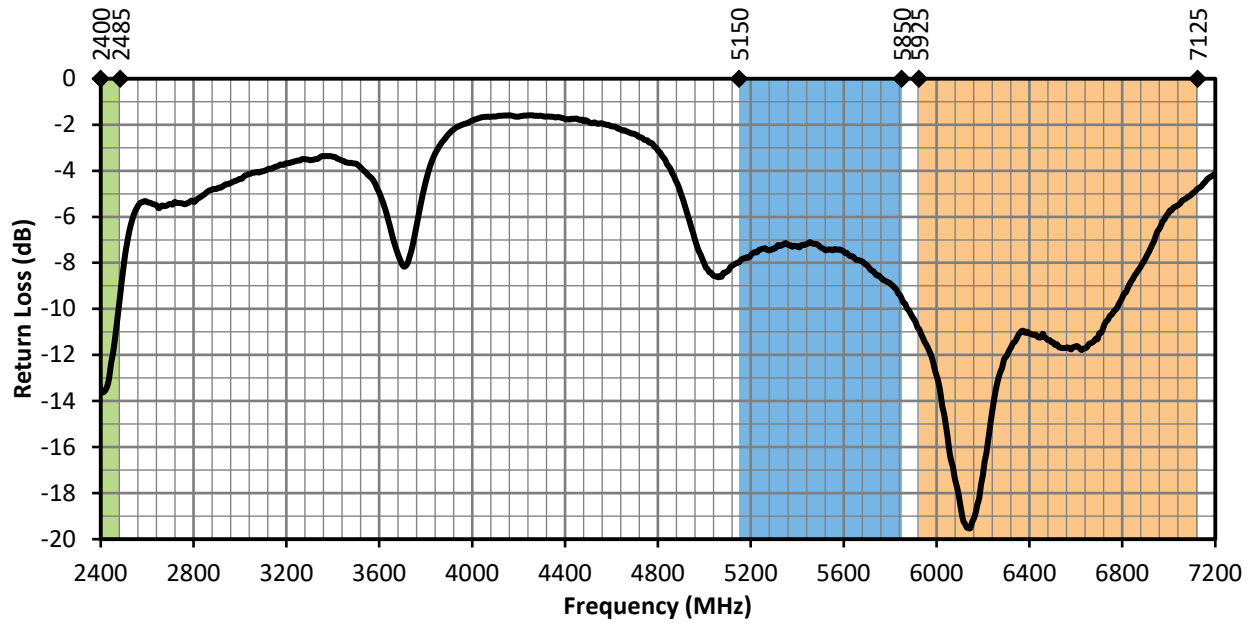

Figure 12. ANT-W63-CW-RCS-ccc Return Loss, on Edge of Ground Plane

Peak Gain

The peak gain across the antenna bandwidth is shown in Figure 13. Peak gain represents the maximum antenna input power concentration across 3-dimensional space, and therefore peak performance at a given frequency, but does not consider any directionality in the gain pattern.

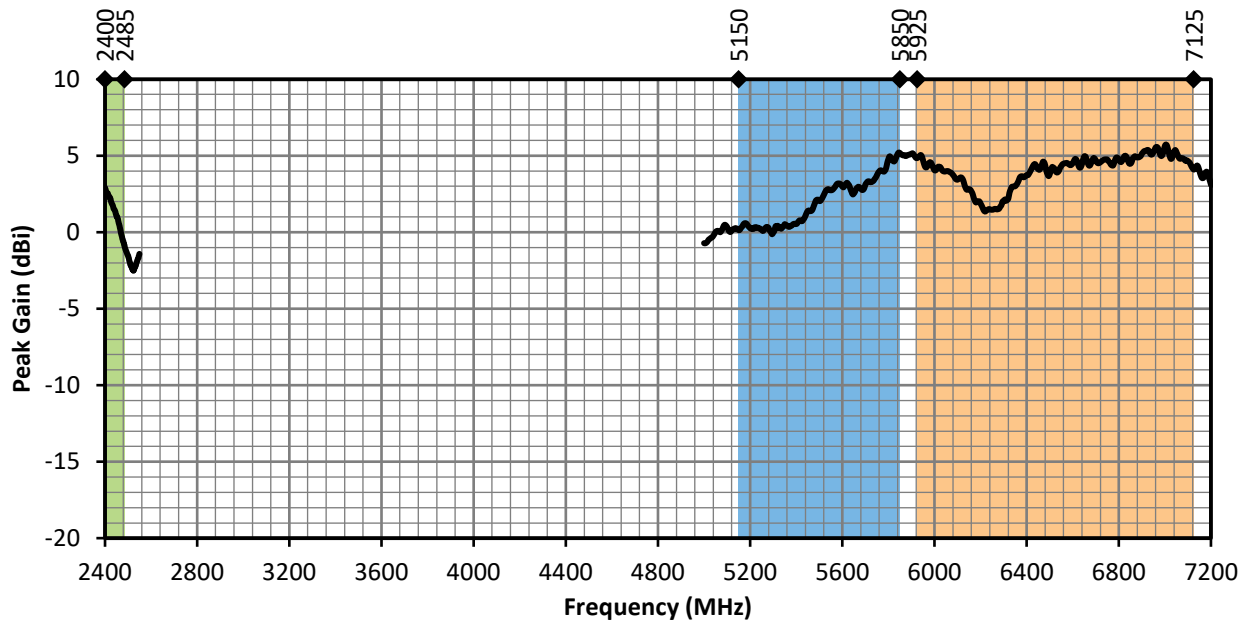

Figure 13. ANT-W63-CW-RCS-ccc Peak Gain, on Edge of Ground Plane

Average Gain

Average gain (Figure 16), is the average of all antenna gain in 3-dimensional space at each frequency, providing an indication of overall performance without expressing antenna directionality.

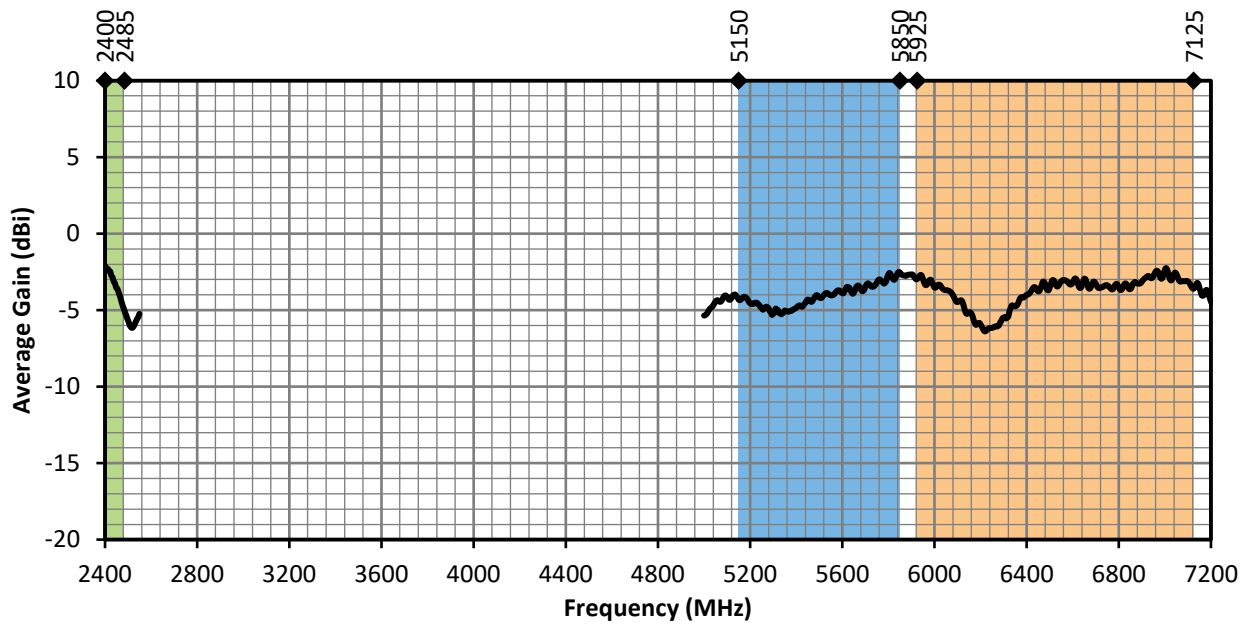

Figure 14. ANT-W63-CW-RCS-ccc Antenna Average Gain, on Edge of Ground Plane

Radiation Efficiency

Radiation efficiency (Figure 15), shows the ratio of power delivered to the antenna relative to the power radiated at the antenna, expressed as a percentage, where a higher percentage indicates better performance at a given frequency.

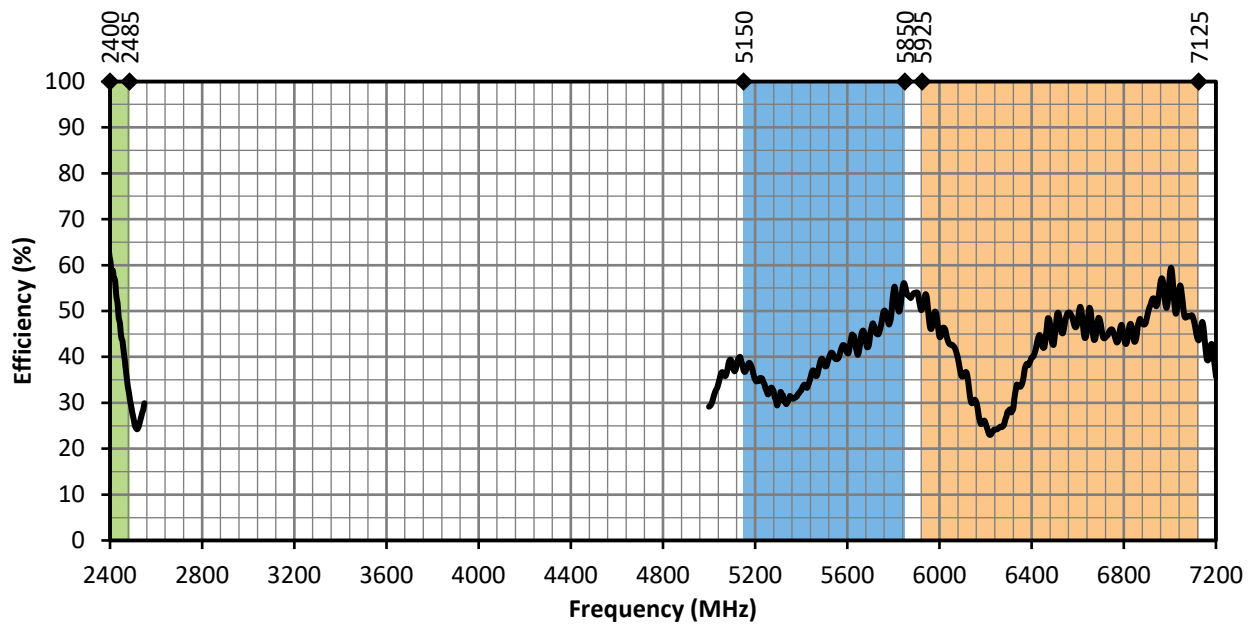
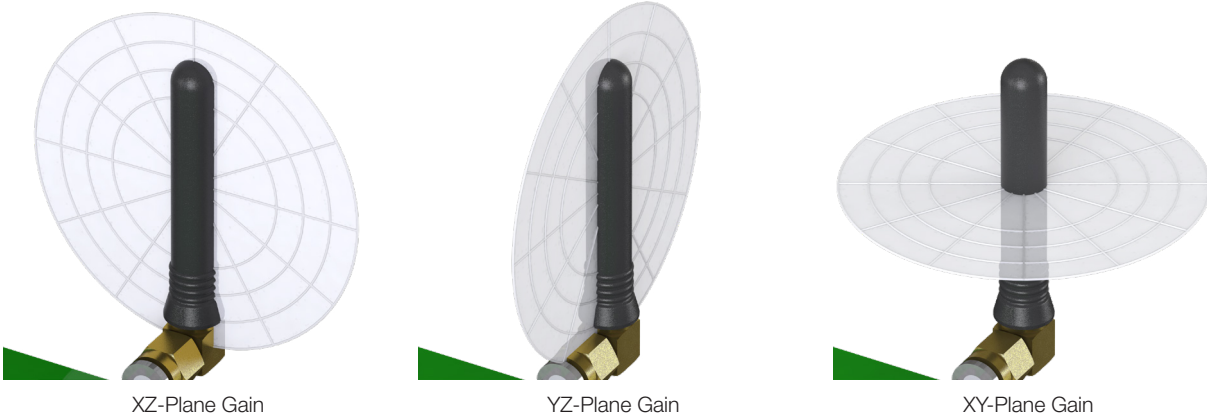

Figure 15. ANT-W63-CW-RCS-ccc Antenna Efficiency, on Edge of Ground Plane

Radiation Patterns

Radiation patterns provide information about the directionality and 3-dimensional gain performance of the antenna by plotting gain at specific frequencies in three orthogonal planes. Antenna radiation patterns for an Edge of Ground Plane orientation are shown in Figure 16 using polar plots covering 360 degrees. The antenna graphic at the top of the page provides reference to the plane of the column of plots below it. Note: when viewed with typical PDF viewing software, zooming into radiation patterns is possible to reveal fine detail.

Radiation Patterns - Edge of Ground Plane



2400 MHz to 2485 MHz (2450 MHz)

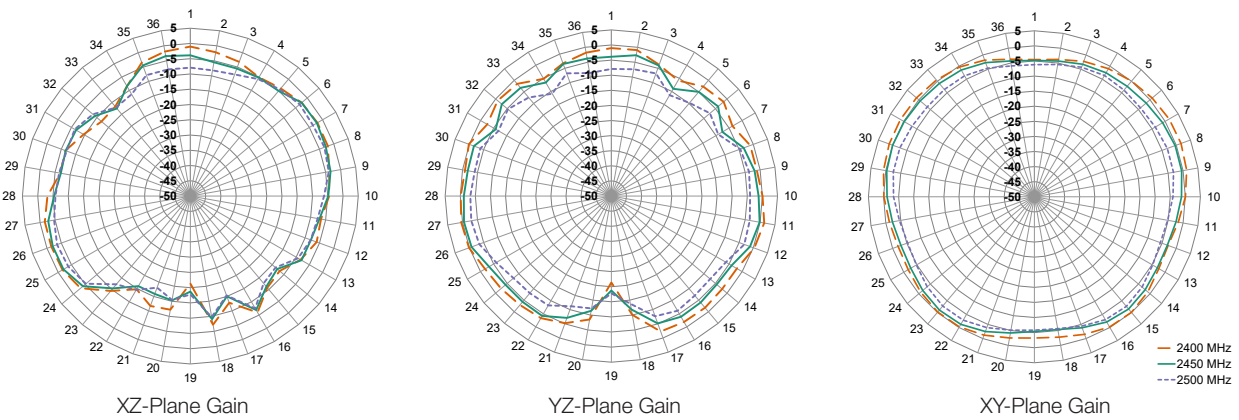

5150 MHz to 5850 MHz (5500 MHz)

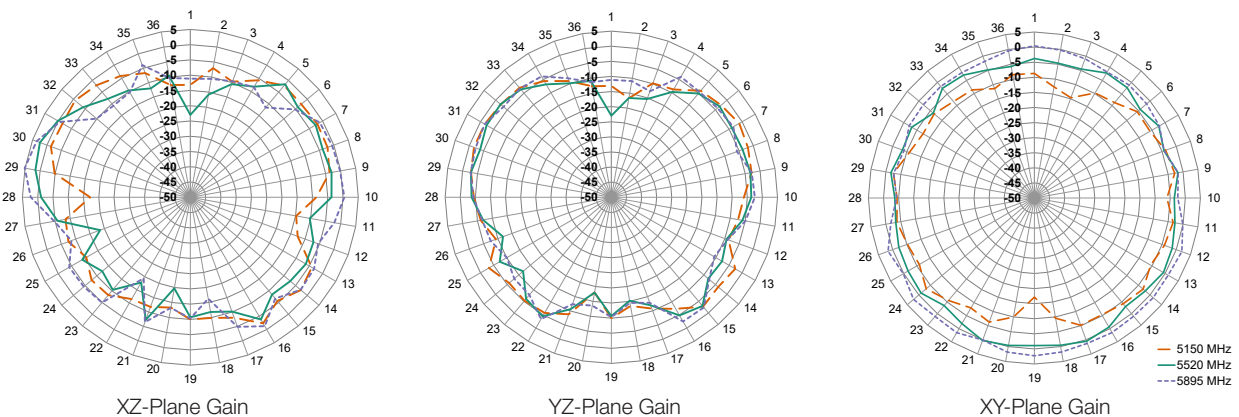

Radiation Patterns - Edge of Ground Plane

5925 MHz to 7125 MHz (6500 MHz)

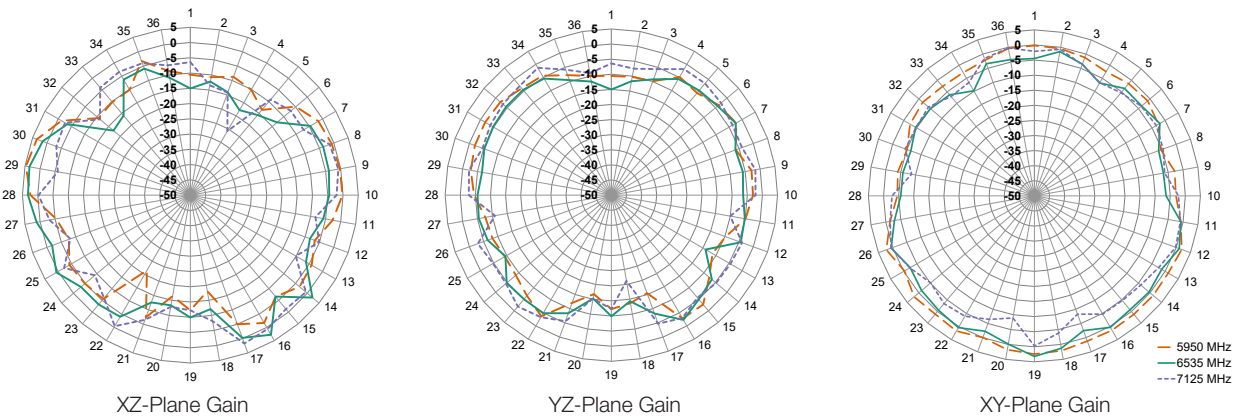

Figure 16. Radiation Patterns for ANT-W63-CW-RCS-ccc, on Edge of Ground Plane

Website: <http://linxtechnologies.com>
Linx Offices: 159 Ort Lane, Merlin, OR, US 97532
Phone: +1 (541) 471-6256
E-MAIL: info@linxtechnologies.com

Linx Technologies reserves the right to make changes to the product(s) or information contained herein without notice. No liability is assumed as a result of their use or application. No rights under any patent accompany the sale of any such product(s) or information.

Wireless Made Simple is a registered trademark of Linx Acquisitions LLC. Other product and brand names may be trademarks or registered trademarks of their respective owners.

Copyright © 2022 Linx Technologies

All Rights Reserved

Doc# DS22262-267ANT Replaces (DS22260-267ANT)

