

PRODUCT NUMBER
75915-YXXXLF

RoHS COMPATIBLE, SEE NOTE 6
OPTIONAL LETTER.
G: HIGH TEMPERATURE BLACK PRODUCT.
H: HIGH TEMPERATURE GREY PRODUCT.
NUMBER OF POSITIONS: 02 TO 50.
PLATING CODE
3= 0.76µm GOLD ON CONTACT AREA.
2µm MIN MATTE TIN ON TAIL.
4= 2µm MIN MATTE TIN FULL PLATED

8= 0.38µm GOLD ON CONTACT AREA.
2µm MIN MATTE TIN ON TAIL.
1.27µm Ni MIN UNDERPLATING

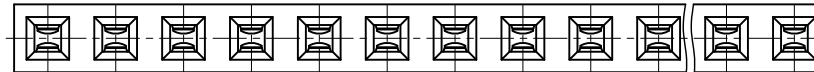

NOTES:

- 1 - HOUSING MAT'L: THERMOPLASTIC GLASS FILLED FLAME RETARDANT PER UL 94 V-0.
LOW TEMPERATURE: COLOR BLUE.
HIGH TEMPERATURE: COLOR GREY OR BLACK.
- 2 - TERMINAL MATERIAL: PHOSPHOR BRONZE.
- 3 - 2 UP TO 4 POSITIONS PRODUCT PACKED IN PLASTIC BOX.
5 UP TO 50 POSITIONS PRODUCT PACKED IN TUBE.
- 4 - TO DETERMINE DIMENSIONS:
N = NUMBER OF POSITIONS
EXAMPLE: 8 POS: (N x 2.54) - 0.08 = 20.24 mm
- 5 - RoHS COMPATIBLE PRODUCT SPECIFICATIONS
 - a - PLATING:
- "LF" MEANS THE PRODUCT IS LEAD-FREE,
2µm MINIMUM MATTE TIN OVER 1.27µm
MINIMUM NICKEL UNDERPLATE.
 - b - MANUFACTURING PROCESS COMPATIBILITY
- THE HOUSING WILL WITHSTAND EXPOSURE TO
260°C ±5°C SOLDER BATH TEMPERATURE FOR
5 SECONDS IN A WAVE SOLDER APPLICATION
WITH A 1.6mm MIN THICK CIRCUIT BOARD.
 - c - LABELING:
- MEETS PACKAGING SPECS AS PER GS-14-920
 - d - LEGAL STATEMENT: SEE GS-47-0004
- 6 - HOLE PATTERN SEE NEXT SHEET.

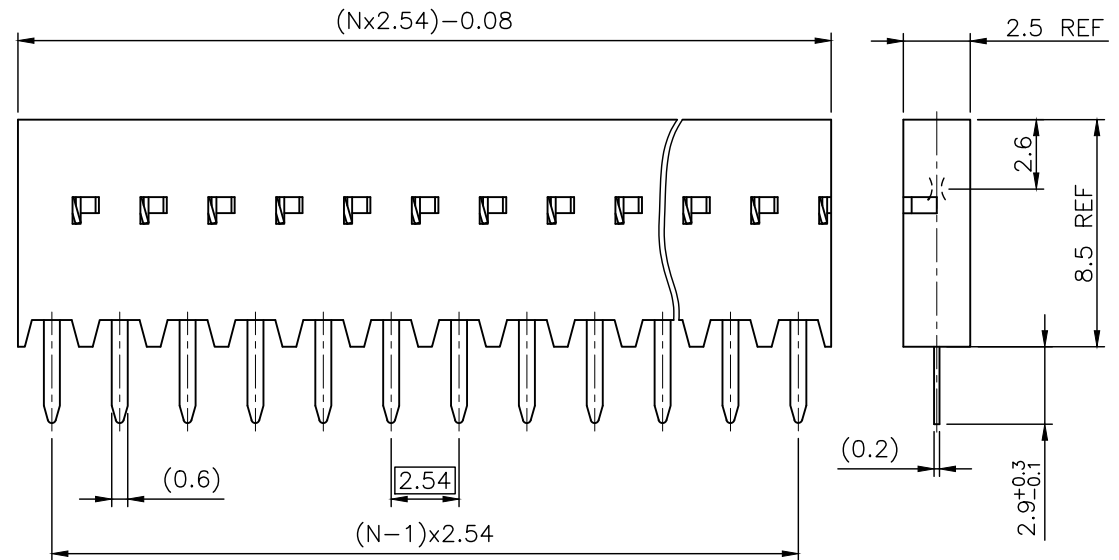

mat'l. code SEE NOTE 1				surface ISO 1302 ✓		tolerance ISO 406 ISO 1101		projection mm		product family DUBOX	
ltr	ecn no	dr	date	tolerances unless otherwise specified		±0.3		mm		title BtB RECEPT. VERT SR TMT	
AD	F06-0204	DLE	06.06.20	angles		linear		scale 5:1		dwg no 75915	
AE	F07-0109	DLE	07.01.16	±2'						sheet 1 of 2	
AF	F09-0030	LMU	09.03.16							size A3	
AG	B-19123	LMU	14.10.21	dr	D.LEGRAND	96.04.01				drawing	
AH	F-45668	DDE	22.08.17	engr	P.NIZZI	96.04.01				type CUSTOMER	
				chr	D.LEGRAND	96.04.01					
AC	F06-0150	DLE	06.03.17	appd	P.NIZZI	96.04.01					
sheet	revision	AH	D								
index	sheet	1	2								

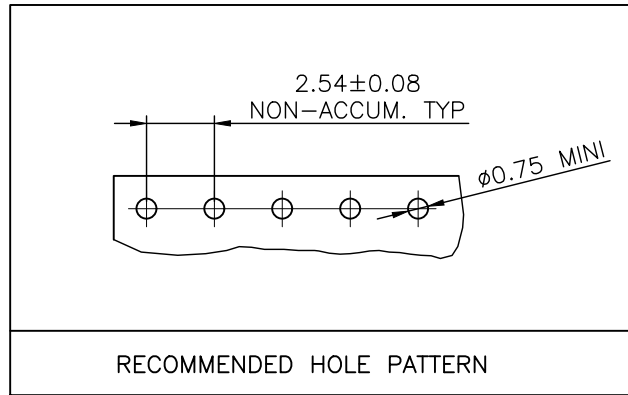

FCI
FCIconnect.com

Copyright FCI

mat'l. code		surface		tolerance		projection		product family	
SEE SHEET 1		ISO 1302 ✓		ISO 406 ISO 1101				DUBOX	
ltr	ecn no	dr	date	tolerances unless otherwise specified				title	
A	F04-0347	DLE	04.09.23	angles	linear	±0.3		BtB RECEPT. VERT SR TMT	
B	F05-0230	DLE	05.08.08			mm			
C	F06-0204	DLE	06.06.20	±2°		scale N/A			
D	F07-0109	DLE	07.01.16	dr		D.LEGRAND 04.09.23			
				engr		P.NIZZI 04.09.23		dwg no	
				chr		D.LEGRAND 04.09.23		sheet 2 of - size	
				appd		P.NIZZI 04.09.23		75915 A4	
sheet index		revision sheet						type CUSTOMER Drawing	

