

# AS85049/79 90° EMI/RFI Environmental Backshell



AS85049

### CONNECTOR DESIGNATOR:

<b>H</b>	MIL-DTL-38999, Series III and IV EN3645
----------	--

**Finish**  
*N* = Electroless Nickel      *X* = Aluminum, Nickel Fluorocarbon Polymer  
*W* = 1,000 Hr. Cadmium Olive Drab      *Z* = Aluminum, Zinc-Nickel, Black over Electroless Nickel

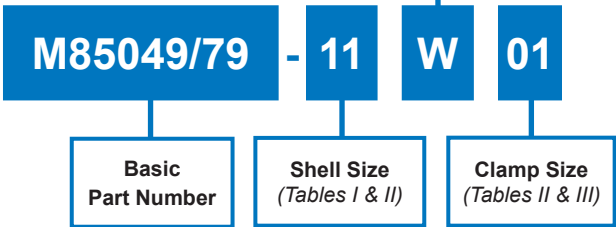
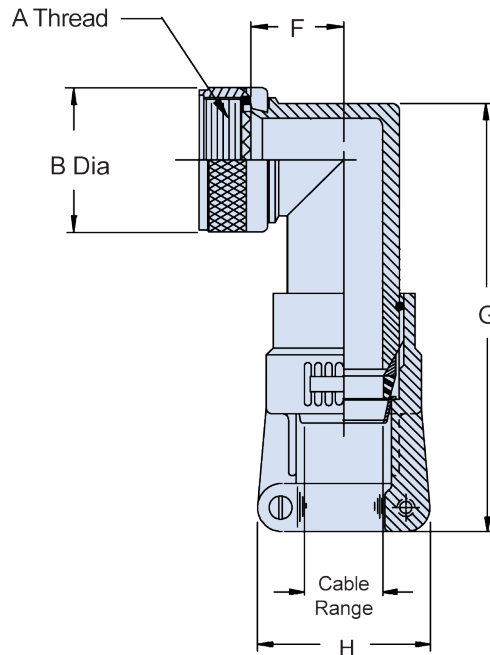

TABLE I: Shell Size, Thread and Dimensions		
Shell Size	A Thread Class 2B	B Dia Max
09	M12 X 1 - 6H	.750 (19.1)
11	M15 X 1 - 6H	.850 (21.6)
13	M18 X 1 - 6H	1.000 (25.4)
15	M22 X 1 - 6H	1.150 (29.2)
17	M25 X 1 - 6H	1.250 (31.8)
19	M28 X 1 - 6H	1.400 (35.6)
21	M31 X 1 - 6H	1.550 (39.4)
23	M34 X 1 - 6H	1.650 (41.9)
25	M37 X 1 - 6H	1.850 (47.0)

TABLE II: Shell Size, Clamp Size and Dimensions				
Shell Size	Clamp Size		F ±.156 (4.0)	G ±.188 (4.8)
	Min	Max		
09	01	02	.532 (13.5)	3.267 (83.0)
11	01	03	.627 (15.9)	3.387 (86.0)
13	02	04	.642 (16.3)	3.407 (86.5)
15	02	05	.719 (18.3)	3.477 (88.3)
17	02	06	.774 (19.7)	3.567 (90.6)
19	03	07	.854 (21.7)	3.737 (94.9)
21	03	08	.899 (22.8)	3.737 (94.9)
23	03	09	1.009 (25.6)	3.847 (97.7)
25	04	10	1.024 (26.0)	3.847 (97.7)



- ### APPLICATION NOTES
- For complete dimensions see the applicable Military Specification.
  - Metric dimensions (mm) are in parentheses.
  - Cable Range is defined as the accommodation range for the wire bundle or cable. Dimensions shown are not intended for inspection criteria.

TABLE III: Clamp Size, Cable Range and Dimensions			
Clamp Size	Cable Range		H Max
	Min	Max	
01	.062 (1.6)	.125 (3.2)	.800 (20.3)
02	.125 (3.2)	.250 (6.4)	1.000 (25.4)
03	.250 (6.4)	.375 (9.5)	1.100 (27.9)
04	.375 (9.5)	.500 (12.7)	1.200 (30.5)
05	.500 (12.7)	.625 (15.9)	1.250 (31.8)
06	.625 (15.9)	.750 (19.1)	1.400 (35.6)
07	.750 (19.1)	.875 (22.2)	1.500 (38.1)
08	.875 (22.2)	1.000 (25.4)	1.650 (41.9)
09	1.000 (25.4)	1.125 (28.6)	1.750 (44.5)
10	1.125 (28.6)	1.250 (31.8)	1.900 (48.3)

Dimensions in inches (millimeters) and are subject to change without notice.

© 2013 Glenair, Inc.

Mil-Spec Backshells

U.S. CAGE Code 06324

Rev. 07.05.22

Printed in U.S.A.

**GLENAIR, INC. • 1211 AIR WAY • GLENDALE, CA 91201-2497 • 818-247-6000 • FAX 818-500-9912**  
**www.glenair.com B-93 E-Mail: sales@glenair.com**

B