

Tip Jacks

APPLICATION • Connection to test equipment • Power supplies • Electrical instruments



Insulated Standard

SPECIFICATIONS:

Contact: Phosphor bronze per QQ-B-750

Finish: Bright tin

Body: Nylon 6/6 per ASTM D4066

Hardware: Nickel plated nut (unassembled)

Body Thread Stripping Torque: 4.0 lb. in.
(4.5 kg. cm.)

Panel Thickness: Up to .437 (11.10)

RATINGS

Current: 10 amps

Breakdown Voltage: 5700 Vrms minimum +

Contact Resistance: 0.010 ohms maximum

Contact-To-Panel C: 2 pF nominal

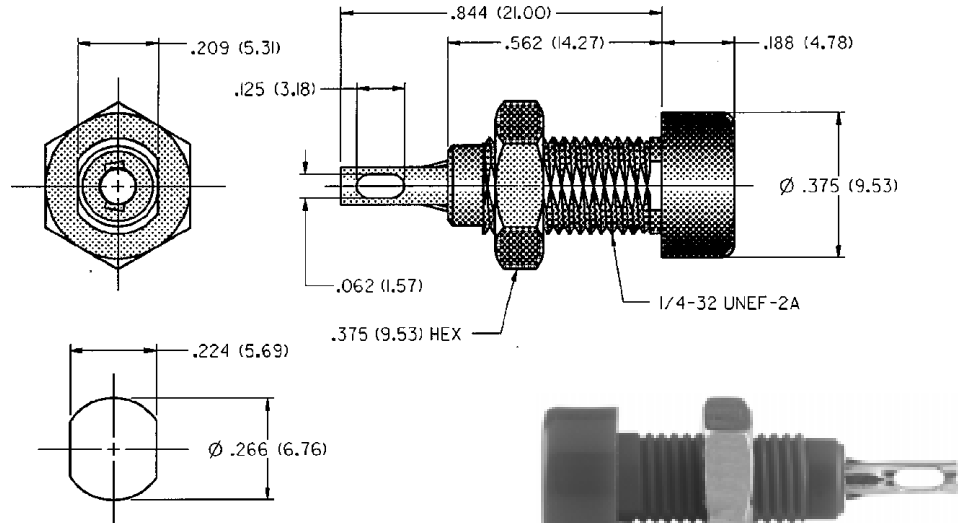

MOUNTING HOLE LAYOUT

For Standard Tip Plug: .080 (2.00) Diameter

FEATURES:

- Formed contact with slotted terminal
- Hex socket head .188 (4.77) for ease in mounting
- Nylon UL approved for self extinguishing

BRIGHT TIN PLATING			
PART NO.	COLOR	PART NO.	COLOR
105-0801-001	White	105-0804-001	Green
105-0802-001	Red	105-0807-001	Yellow
105-0803-001	Black	105-0810-001	Blue