

1206 Multilayer Ferrite Chip Bead

ACML-1206



RoHS
Compliant



3.2 x 1.6 x 0.9mm

FEATURES:

- Multilayer monolithic construction yields high reliability
- Nickel barrier terminations provide excellent solder heat resistance
- Suitable for flow and RoHS reflow soldering

APPLICATIONS:

- Video equipment, audio equipment
- Automotive electrical equipment
- Communication equipment
- OA equipment and other

STANDARD SPECIFICATIONS:

PARAMETERS

ABRACON P/N:	ACML-1206
Operating temperature:	-55°C to + 125°C
Storage temperature:	-55°C to + 125°C

Part No.	Z (Ω) ± 25%	Z Test Freq.	RDC (Ω)	Ir (mA)
		(MHz)	(max)	(max)
ACML-1206-19	19	100	0.05	2000
ACML-1206-26	26	100	0.05	2000
ACML-1206-31	31	100	0.05	2000
ACML-1206-36	36	100	0.05	2000
ACML-1206-66	60	100	0.08	1000
ACML-1206-80	80	100	0.08	1000
ACML-1206-100	100	100	0.10	1000
ACML-1206-120	120	100	0.10	600
ACML-1206-150	150	100	0.15	600
ACML-1206-180	180	100	0.15	600
ACML-1206-300	300	100	0.20	600
ACML-1206-390	390	100	0.20	600
ACML-1206-500	500	100	0.30	600
ACML-1206-600	600	100	0.30	600
ACML-1206-750	750	100	0.30	600
ACML-1206-1000	1000	50	0.40	500
ACML-1206-1200	1200	50	0.50	300
ACML-1206-1500	1500	50	0.60	200
ACML-1206-2000	2000	50	0.70	200
ACML-1206-2500	2500	50	0.70	200
ACML-1206-3000	3000	50	1.00	200

Test Conditions and equipments

Z: HP4291 Impedance Analyzer, 100MHz or 50MHz, 50mV

DCR: HP4263A LCR meter

Ir: Electric Power Supplier, Electric Current Meter, Thermometer. ΔT ≤ 20°C

Unless otherwise specified

Temperature : Ordinary Temperature (5 to 35°C)

Humidity : Ordinary Humidity (25 to 85% RH)

OPTIONS AND PART IDENTIFICATION:

(Left blank if standard)

ACML-1206- -

Impedance Code

Please refer to
Electrical Spec table

Packaging

T: Tape and Reel (3kpcs / reel)

ABRACON IS
ISO 9001:2008
CERTIFIED



ABRACON
CORPORATION

Visit www.abracon.com for Terms & Conditions of Sale

Revised: 10.27.11

30332 Esperanza, Rancho Santa Margarita, California 92688

tel 949-546-8000 | fax 949-546-8001 | www.abracon.com

1206 Multilayer Ferrite Chip Bead

ACML-1206



RoHS
Compliant



3.2 x 1.6 x 0.9mm

OUTLINE DRAWING:

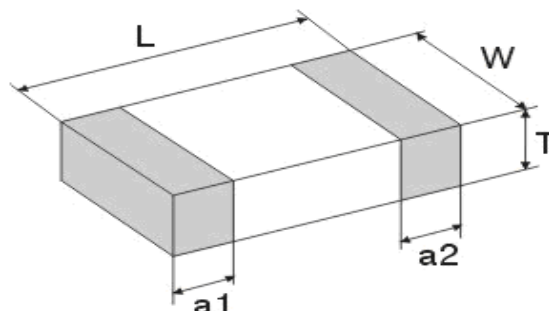

Dimension: mm [inch]

Series	L	W	T	a1,a2
ACML-1206	3.20±0.20	1.60±0.20	0.90±0.20	0.50±0.30
	[0.126±0.008]	[0.063±0.008]	[0.035±0.008]	[0.02±0.012]

REFLOW PROFILE:

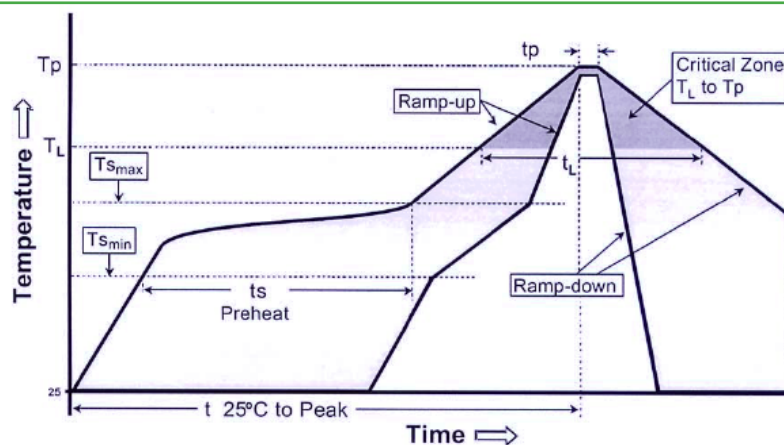

Profile Feature	Lead-Free Assembly
Average Ramp-Up Rate (T _{smax} to T _p)	3°C /second max.
Preheat - Temperature Min (T _{smin}) - Temperature Max (T _{smax}) - Time (t _{smin} to t _{smax}) min to t _{smax})	150 °C 200 °C 60-180 seconds
Time maintained above: - Temperature (T _L) - Time (t _L)	217 °C 60-150 seconds
Peak/Classification Temperature (T _p) Peak/Classification Time (T _p)	260 °C 3-4 seconds
Time within 5 °C of actual Peak Temperature (t _p)	20-40 seconds
Ramp-Down Rate	6°C/second max.
Time 25 °C to Peak Temperature	8 minutes max.

1206 Multilayer Ferrite Chip Bead

ACML-1206



RoHS
Compliant



3.2 x 1.6 x 0.9mm

OUTLINE DRAWING:

T: 3,000pcs / reel

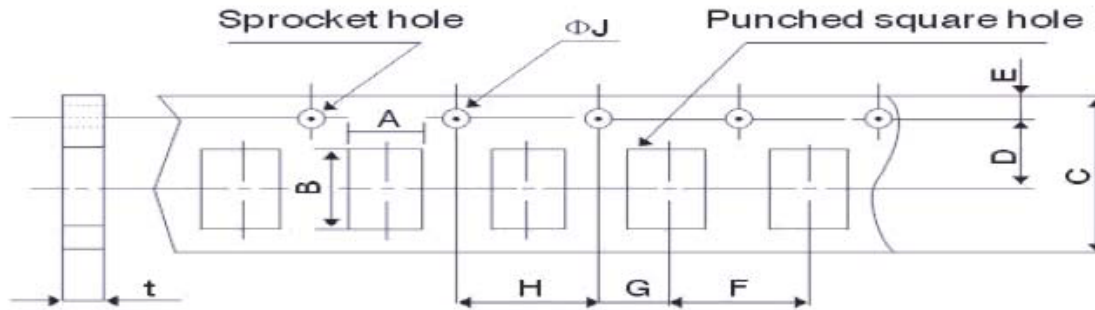

Codes	A	B	C	D	E	F	G	H	ΦJ	t(max)
ACML-1206	2.0±0.2	3.6±0.2	8.0±0.3	3.5±0.05	1.75±0.1	4.0±0.1	2.0±0.05	4.0±0.1	1.5+0.1/-0	2.0±0.05

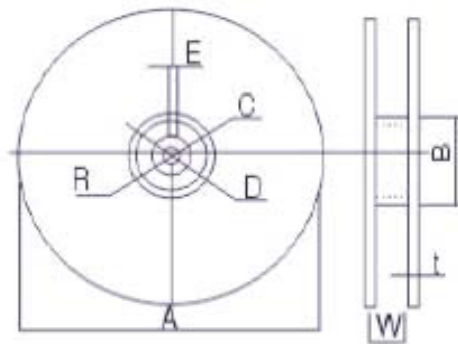

A	178±2
B	60±2
C	13.0±0.5
D	21.0±0.8
E	2.0±0.5
W	10.0±1.15
t	1.2±0.2
R	1.0±0.25

6.1 Peeling strength of cover tape

0.3~0.7N (30gf~70gf)

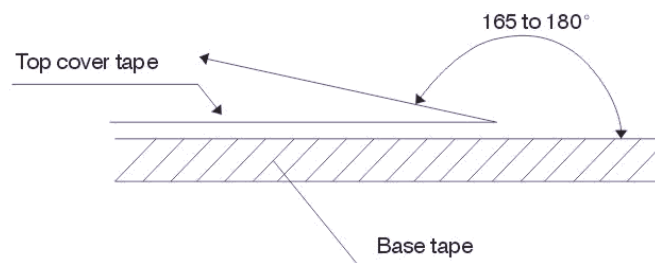

Test condition:

- 1) peel angle: 165°~180° vs. carrier tape.
- 2) peel speed: 300 mm/min±10%.

Dimension: mm

ATTENTION: Abracon Corporation's products are COTS – Commercial-Off-The-Shelf products; suitable for Commercial, Industrial and, where designated, Automotive Applications. Abracon's products are not specifically designed for Military, Aviation, Aerospace, Life-dependant Medical applications or any application requiring high reliability where component failure could result in loss of life and/or property. For applications requiring high reliability and/or presenting an extreme operating environment, written consent and authorization from Abracon Corporation is required. Please contact Abracon Corporation for more information.

ABRACON IS
ISO 9001:2008
CERTIFIED



Visit www.abracon.com for Terms & Conditions of Sale
30332 Esperanza, Rancho Santa Margarita, California 92688
tel 949-546-8000 | fax 949-546-8001 | www.abracon.com

Revised: 10.27.11

Mouser Electronics

Authorized Distributor

Click to View Pricing, Inventory, Delivery & Lifecycle Information:

[ABRACON:](#)

[ACML-1206-600-T](#) [ACML-1206-80-T](#)