

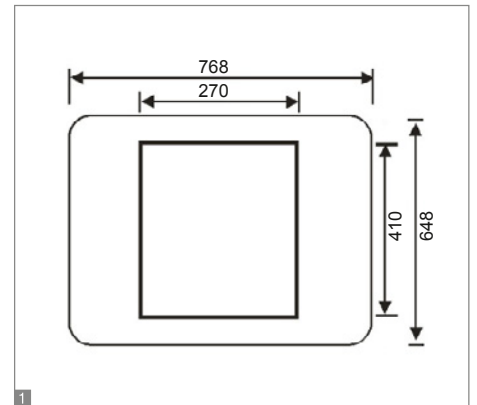

Weighing table

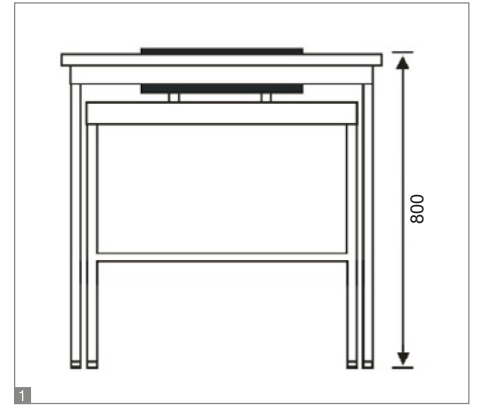

Features

The KERN YPS-03 weighing table has been constructed to absorb vibrations and oscillations, which would otherwise distort the weighing result.

The YPS-03 weighing table consists of:

- a heavy, polished granite slab (34 kg) and is positioned on absorbing rubber components and is used as a surface on which to stand the analytical balance
- a work table, the work surface of which surrounds the slab and offers many storage options. The sturdy powder-coated steel frame has four height-adjustable feet, which can be used to accurately level the weighing table if the floor is at all uneven
- You can work in an ergonomic way at the weighing table whether you are in a standing or seated position. The inlet on the front of the table offers enough space for you to sit down and operate the scale without touching the weighing table.

Technical data

- All surfaces are easy and hygienic to clean
- Suitable for all KERN analytical balances with total dimensions $\leq W \times D$ 270×410 mm
- Total dimensions $W \times D \times H$ 768×648×800 mm (Height adjustable)
- Dimensions granite slab, $W \times D \times H$ 270×410×115 mm
- Net weight approx. 62 kg

Ready for shipping in 2 working days. Dispatch complete on pallet. Please ask for dimensions, gross weight, shipping costs

STANDARD



KERN Pictograms

 Internal adjusting: Quick setting up of the balance's accuracy with internal adjusting weight (motordriven)	 GLP/ISO log: The balance displays serial number, user ID, weight, date and time, regardless of a printer connection	 Suspended weighing: Load support with hook on the underside of the balance
 Adjusting program CAL: For quick setting up of the balance's accuracy. External adjusting weight required	 GLP/ISO log: With weight, date and time. Only with KERN printers	 Battery operation: Ready for battery operation. The battery type is specified for each device
 Memory: Balance memory capacity, e.g. for article data, weighing data, tare weights, PLU etc.	 Piece counting: Reference quantities selectable. Display can be switched from piece to weight	 Rechargeable battery pack: Rechargeable set
 Alibi memory: Secure, electronic archiving of weighing results, complying with the 2014/31/EU standard.	 Recipe level A: The weights of the recipe ingredients can be added together and the total weight of the recipe can be printed out	 Universal mains adapter: with universal input and optional input socket adapters for A) EU, GB B) EU, GB, CH, USA C) EU, GB, CH, USA, AUS
 Data interface RS-232: To connect the balance to a printer, PC or network	 Recipe level B: Internal memory for complete recipes with name and target value of the recipe ingredients. User guidance through display	 Mains adapter: 230V/50Hz in standard version for EU. On request GB, USA or AUS version available
 RS-485 data interface: To connect the balance to a printer, PC or other peripherals. Suitable for data transfer over large distances. Network in bus topology is possible	 Recipe level C: Internal memory for complete recipes with name and target value of the recipe ingredients. User guidance through display, multiplier function, adjustment of recipe when dosages are exceeded or barcode recognition	 Power supply: Integrated in balance. 230V/50Hz standard EU. More standards e.g. GB, USA or AUS on request
 USB data interface: To connect the balance to a printer, PC or other peripherals	 Totalising level A: The weights of similar items can be added together and the total can be printed out	 Weighing principle: Strain gauges Electrical resistor on an elastic deforming body
 Bluetooth* data interface: To transfer data from the balance to a printer, PC or other peripherals	 Percentage determination: Determining the deviation in % from the target value (100 %)	 Weighing principle: Tuning fork A resonating body is electromagnetically excited, causing it to oscillate
 WLAN data interface: To transfer data from the balance to a printer, PC or other peripherals	 Weighing units: Can be switched to e.g. nonmetric units at the touch of a key. See balance model. Please refer to KERN's website for more details	 Weighing principle: Electromagnetic force compensation Coil inside a permanent magnet. For the most accurate weighings
 Control outputs (optocoupler, digital I/O): To connect relays, signal lamps, valves, etc.	 Weighing with tolerance range: (Check-weighing) Upper and lower limiting can be programmed individually, e.g. for sorting and dosing. The process is supported by an audible or visual signal, see the relevant model	 Weighing principle: Single cell technology Advanced version of the force compensation principle with the highest level of precision
 Interface for second balance: For direct connection of a second balance	 Hold function: (Animal weighing program) When the weighing conditions are unstable, a stable weight is calculated as an average value	 Verification possible: The time required for verification is specified in the pictogram +3 DAYS
 Network interface: For connecting the scale to an Ethernet network	 Protection against dust and water splashes IPxx: The type of protection is shown in the pictogram.	 DAkkS calibration possible (DKD): The time required for DAkkS calibration is shown in days in the pictogram +3 DAYS
 Wireless data transfer: between the weighing unit and the evaluation unit using an integrated radio module	 Stainless steel: The balance is protected against corrosion	 Package shipment: The time required for internal shipping preparations is shown in days in the pictogram 1 DAY
 KERN Communication Protocol (KCP): It is a standardized interface command set for KERN balances and other instruments, which allows retrieving and controlling all relevant parameters and functions of the device. KERN devices featuring KCP are thus easily integrated with computers, industrial controllers and other digital systems		 Pallet shipment: The time required for internal shipping preparations is shown in days in the pictogram 2 DAYS

KERN – Precision is our business

To ensure the high precision of your balance KERN offers you the the appropriate test weight in the international OIML error limit classes E1-M3 from 1 mg - 2500 kg. In combination with a DAkkS calibration certificate the best pre-requisite for proper balance calibration.

The KERN DAkkS calibration laboratory today is one of the most modern and best-equipped DAkkS calibration laboratories for balances, test weights and force-measurement in Europe.

Thanks to the high level of automation, we can carry out DAkkS calibration of balances, test weights and force-measuring devices 24 hours a day, 7 days a week.

Range of services:

- DAkkS calibration of balances with a maximum load of up to 50 t
- DAkkS calibration of weights in the range of 1 mg – 2500 kg
- Volume determination and measuring of magnetic susceptibility (magnetic characteristics) for test weights
- Database supported management of checking equipment and reminder service
- Calibration of force-measuring devices
- DAkkS calibration certificates in the following languages DE, GB, FR, IT, ES, NL, PL
- Conformity evaluation and reverification of balances and test weights

Your KERN specialist dealer: