

CHIP COILS (CHIP INDUCTORS) LQW18AN□□□□00□ REFERENCE SPECIFICATION

1. Scope

This reference specification applies to chip coils (chip inductors) LQW18AN_00 series for general electronic equipment.

2. Part Numbering

(Ex.)

LQ	W	18	A	N	2N2	D	0	0	D
Product ID	Structure	Dimension (L × W)	Application and characteristic	Category	Inductance	Tolerance	Performance	Electrode specification	Packaging D: taping *B: bulk

*B: Bulk packing is also available (taping condition: however, products without reels are put in plastic bags).

3. Part Number and Rating

Operating temperature range	-55°C to +125°C
Storage temperature range	-55°C to +125°C

Customer Part number	Murata Part number	Inductance		Q (Min.)	DC resistance (Ω max.)	Self-resonant frequency (MHz min.)	Rated current (mA)
		Nominal value (nH)	Tolerance				
	LQW18AN2N2D00D	2.2	D: ±0.5 nH	16	0.042	6000	700
	LQW18AN3N6C00D	3.6	C: ±0.2 nH	25	0.059	6000	850
	LQW18AN3N6D00D	3.6	D: ±0.5 nH	25	0.059	6000	850
	LQW18AN3N9C00D	3.9	C: ±0.2 nH	35	0.059	6000	850
	LQW18AN3N9D00D	3.9	D: ±0.5 nH	35	0.059	6000	850
	LQW18AN4N3C00D	4.3	C: ±0.2 nH	35	0.059	6000	850
	LQW18AN4N3D00D	4.3	D: ±0.5 nH	35	0.059	6000	850
	LQW18AN4N7D00D	4.7	D: ±0.5 nH	35	0.059	6000	850
	LQW18AN5N6C00D	5.6	C: ±0.2 nH	35	0.082	6000	750
	LQW18AN5N6D00D	5.6	D: ±0.5 nH	35	0.082	6000	750
	LQW18AN6N2C00D	6.2	C: ±0.2 nH	35	0.082	6000	750
	LQW18AN6N2D00D	6.2	D: ±0.5 nH	35	0.082	6000	750
	LQW18AN6N8C00D	6.8	C: ±0.2 nH	35	0.082	6000	750
	LQW18AN6N8D00D	6.8	D: ±0.5 nH	35	0.082	6000	750
	LQW18AN7N5C00D	7.5	C: ±0.2 nH	35	0.082	6000	750
	LQW18AN7N5D00D	7.5	D: ±0.5 nH	35	0.082	6000	750
	LQW18AN8N2C00D	8.2	C: ±0.2 nH	35	0.11	6000	650
	LQW18AN8N2D00D	8.2	D: ±0.5 nH	35	0.11	6000	650
	LQW18AN8N7C00D	8.7	C: ±0.2 nH	35	0.11	6000	650
	LQW18AN8N7D00D	8.7	D: ±0.5 nH	35	0.11	6000	650
	LQW18AN9N1C00D	9.1	C: ±0.2 nH	35	0.11	6000	650
	LQW18AN9N1D00D	9.1	D: ±0.5 nH	35	0.11	6000	650
	LQW18AN9N5D00D	9.5	D: ±0.5 nH	35	0.11	6000	650
	LQW18AN10NG00D	10	G: ±2%	35	0.11	6000	650
	LQW18AN10NJ00D	10	J: ±5%	35	0.11	6000	650
	LQW18AN11NG00D	11	G: ±2%	35	0.11	6000	650
	LQW18AN11NJ00D	11	J: ±5%	35	0.11	6000	650
	LQW18AN12NG00D	12	G: ±2%	35	0.13	6000	600
	LQW18AN12NJ00D	12	J: ±5%	35	0.13	6000	600
	LQW18AN13NG00D	13	G: ±2%	35	0.13	6000	600
	LQW18AN13NJ00D	13	J: ±5%	35	0.13	6000	600

Customer Part number	Murata Part number	Inductance		Q (Min.)	DC resistance (Ω max.)	Self-resonant frequency (MHz min.)	Rated current (mA)
		Nominal value (nH)	Tolerance				
	LQW18AN15NG00D	15	G: $\pm 2\%$	40	0.13	6000	600
	LQW18AN15NJ00D	15	J: $\pm 5\%$	40	0.13	6000	600
	LQW18AN16NG00D	16	G: $\pm 2\%$	40	0.16	5500	550
	LQW18AN16NJ00D	16	J: $\pm 5\%$	40	0.16	5500	550
	LQW18AN18NG00D	18	G: $\pm 2\%$	40	0.16	5500	550
	LQW18AN18NJ00D	18	J: $\pm 5\%$	40	0.16	5500	550
	LQW18AN20NG00D	20	G: $\pm 2\%$	40	0.16	4900	550
	LQW18AN20NJ00D	20	J: $\pm 5\%$	40	0.16	4900	550
	LQW18AN22NG00D	22	G: $\pm 2\%$	40	0.17	4600	500
	LQW18AN22NJ00D	22	J: $\pm 5\%$	40	0.17	4600	500
	LQW18AN24NG00D	24	G: $\pm 2\%$	40	0.21	3800	500
	LQW18AN24NJ00D	24	J: $\pm 5\%$	40	0.21	3800	500
	LQW18AN27NG00D	27	G: $\pm 2\%$	40	0.21	3700	440
	LQW18AN27NJ00D	27	J: $\pm 5\%$	40	0.21	3700	440
	LQW18AN30NG00D	30	G: $\pm 2\%$	40	0.23	3300	420
	LQW18AN30NJ00D	30	J: $\pm 5\%$	40	0.23	3300	420
	LQW18AN33NG00D	33	G: $\pm 2\%$	40	0.23	3200	420
	LQW18AN33NJ00D	33	J: $\pm 5\%$	40	0.23	3200	420
	LQW18AN36NG00D	36	G: $\pm 2\%$	40	0.26	2900	400
	LQW18AN36NJ00D	36	J: $\pm 5\%$	40	0.26	2900	400
	LQW18AN39NG00D	39	G: $\pm 2\%$	40	0.26	2800	400
	LQW18AN39NJ00D	39	J: $\pm 5\%$	40	0.26	2800	400
	LQW18AN43NG00D	43	G: $\pm 2\%$	40	0.29	2700	380
	LQW18AN43NJ00D	43	J: $\pm 5\%$	40	0.29	2700	380
	LQW18AN47NG00D	47	G: $\pm 2\%$	38	0.29	2600	380
	LQW18AN47NJ00D	47	J: $\pm 5\%$	38	0.29	2600	380
	LQW18AN51NG00D	51	G: $\pm 2\%$	38	0.33	2500	370
	LQW18AN51NJ00D	51	J: $\pm 5\%$	38	0.33	2500	370
	LQW18AN56NG00D	56	G: $\pm 2\%$	38	0.35	2400	360
	LQW18AN56NJ00D	56	J: $\pm 5\%$	38	0.35	2400	360
	LQW18AN62NG00D	62	G: $\pm 2\%$	38	0.51	2300	280
	LQW18AN62NJ00D	62	J: $\pm 5\%$	38	0.51	2300	280
	LQW18AN68NG00D	68	G: $\pm 2\%$	38	0.38	2200	340
	LQW18AN68NJ00D	68	J: $\pm 5\%$	38	0.38	2200	340
	LQW18AN72NG00D	72	G: $\pm 2\%$	34	0.56	2100	270
	LQW18AN72NJ00D	72	J: $\pm 5\%$	34	0.56	2100	270
	LQW18AN75NG00D	75	G: $\pm 2\%$	34	0.56	2050	270
	LQW18AN75NJ00D	75	J: $\pm 5\%$	34	0.56	2050	270
	LQW18AN82NG00D	82	G: $\pm 2\%$	34	0.60	2000	250
	LQW18AN82NJ00D	82	J: $\pm 5\%$	34	0.60	2000	250
	LQW18AN91NG00D	91	G: $\pm 2\%$	34	0.64	1900	230
	LQW18AN91NJ00D	91	J: $\pm 5\%$	34	0.64	1900	230
	LQW18ANR10G00D	100	G: $\pm 2\%$	34	0.68	1800	220
	LQW18ANR10J00D	100	J: $\pm 5\%$	34	0.68	1800	220
	LQW18ANR11G00D	110	G: $\pm 2\%$	32	1.2	1700	200
	LQW18ANR11J00D	110	J: $\pm 5\%$	32	1.2	1700	200

Customer Part number	Murata Part number	Inductance		Q (Min.)	DC resistance (Ω max.)	Self-resonant frequency (MHz min.)	Rated current (mA)
		Nominal value (nH)	Tolerance				
	LQW18ANR12G00D	120	G: $\pm 2\%$	32	1.3	1600	180
	LQW18ANR12J00D	120	J: $\pm 5\%$	32	1.3	1600	180
	LQW18ANR13G00D	130	G: $\pm 2\%$	32	1.4	1450	170
	LQW18ANR13J00D	130	J: $\pm 5\%$	32	1.4	1450	170
	LQW18ANR15G00D	150	G: $\pm 2\%$	32	1.5	1400	160
	LQW18ANR15J00D	150	J: $\pm 5\%$	32	1.5	1400	160
	LQW18ANR16G00D	160	G: $\pm 2\%$	32	2.1	1350	150
	LQW18ANR16J00D	160	J: $\pm 5\%$	32	2.1	1350	150
	LQW18ANR18G00D	180	G: $\pm 2\%$	25	2.2	1300	140
	LQW18ANR18J00D	180	J: $\pm 5\%$	25	2.2	1300	140
	LQW18ANR20G00D	200	G: $\pm 2\%$	25	2.4	1250	120
	LQW18ANR20J00D	200	J: $\pm 5\%$	25	2.4	1250	120
	LQW18ANR22G00D	220	G: $\pm 2\%$	25	2.5	1200	120
	LQW18ANR22J00D	220	J: $\pm 5\%$	25	2.5	1200	120
	LQW18ANR27G00D	270	G: $\pm 2\%$	30	3.4	960	110
	LQW18ANR27J00D	270	J: $\pm 5\%$	30	3.4	960	110
	LQW18ANR33G00D	330	G: $\pm 2\%$	30	5.5	800	85
	LQW18ANR33J00D	330	J: $\pm 5\%$	30	5.5	800	85
	LQW18ANR39G00D	390	G: $\pm 2\%$	30	6.2	800	80
	LQW18ANR39J00D	390	J: $\pm 5\%$	30	6.2	800	80
	LQW18ANR47G00D	470	G: $\pm 2\%$	30	7.0	700	75
	LQW18ANR47J00D	470	J: $\pm 5\%$	30	7.0	700	75

4. Testing Conditions

Unless otherwise specified	Temperature: ordinary temperature (15°C to 35°C) Humidity: ordinary humidity [25% to 85% (RH)]
In case of doubt	Temperature: 20°C \pm 2°C Humidity: 60% to 70% (RH) Atmospheric pressure: 86 kPa to 106 kPa

5. Appearance and Dimensions

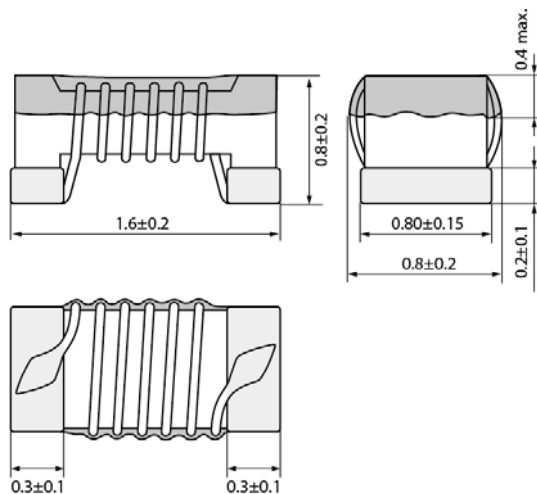

(in mm)

Unit mass (typical value): 0.003 g

6. Marking

No marking.

7. Electrical Performance

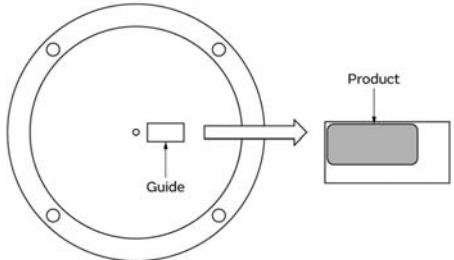
No.	Item	Specification	Test method												
7.1	Inductance	Meet chapter 3 ratings.	Measuring equipment: Keysight E4991A or the equivalent Measuring frequency: <table border="1" data-bbox="927 461 1430 636"> <tr> <td>Inductance</td> <td colspan="2">100 MHz</td> </tr> <tr> <td rowspan="4">Q</td> <td>250 MHz</td> <td>2.2 nH to 39 nH</td> </tr> <tr> <td>200 MHz</td> <td>43 nH to 68 nH</td> </tr> <tr> <td>150 MHz</td> <td>72 nH to 160 nH</td> </tr> <tr> <td>100 MHz</td> <td>180 nH to 470 nH</td> </tr> </table> Measuring conditions: Measurement signal level: Approx. 0 dBm Measurement terminal distance: 1.0 mm Electrical length: 10.0 mm Measuring fixture: Keysight 16197A Position the chip coil under test as shown in the measuring example below and connect it to the electrode by applying weight.	Inductance	100 MHz		Q	250 MHz	2.2 nH to 39 nH	200 MHz	43 nH to 68 nH	150 MHz	72 nH to 160 nH	100 MHz	180 nH to 470 nH
Inductance	100 MHz														
Q	250 MHz	2.2 nH to 39 nH													
	200 MHz	43 nH to 68 nH													
	150 MHz	72 nH to 160 nH													
	100 MHz	180 nH to 470 nH													
7.2	Q	Meet chapter 3 ratings.	Measurement example:  Measuring method: see "Electrical performance: Measuring method for inductance/Q" in the chapter "14. Appendix".												
7.3	DC resistance	Meet chapter 3 ratings.	Measuring equipment: digital multimeter												
7.4	Self-resonant frequency	Meet chapter 3 ratings.	Measuring equipment: Keysight N5230A or the equivalent												
7.5	Rated current	Product temperature rise: 20°C max. Inductance change rate: within ±10%	Apply the rated current specified in chapter 3.												

8. Mechanical Performance

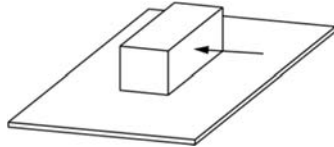
No.	Item	Specification	Test method
8.1	Shear test	No significant mechanical damage or no sign of electrode peeling off shall be observed.	Test substrate: glass-epoxy substrate Force application direction:  Applying force: 5 N Holding time: 5 s±1 s

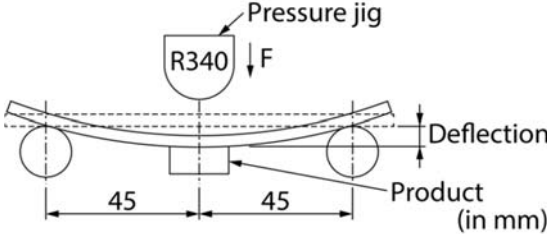
No.	Item	Specification	Test method
8.2	Bending test	No significant mechanical damage or no sign of electrode peeling off shall be observed.	<p>Test substrate: glass-epoxy substrate (100mm × 40 mm × 1.6 mm) Pressurizing speed: 1 mm/s Deflection: 2 mm Holding time: 30 s</p> 
8.3	Vibration	Appearance shall have no significant mechanical damage.	<p>Oscillation frequency: 10 Hz to 55 Hz to 10 Hz, for approx. 1 min Total amplitude: 1.5 mm Test time: 3 directions perpendicular to each other, 2 h for each direction (6 h in total)</p>
8.4	Solderability	90% or more of the outer electrode shall be covered with new solder seamlessly.	<p>Flux: immersed in ethanol solution [including an activator with a chlorine conversion value of 0.06(wt)%] with a rosin content of 25(wt)% for 5 s to 10 s. Solder: Sn-3.0Ag-0.5Cu solder Pre-heating: 150°C±10°C/60 s to 90 s Solder temperature: 240°C±5°C Immersion time: 3 s±1 s</p>
8.5	Resistance to soldering heat	Appearance: No significant mechanical damage shall be observed. Inductance change rate: within ±5%	<p>Flux: immersed in ethanol solution [including an activator with a chlorine conversion value of 0.06(wt)%] with a rosin content of 25(wt)% for 5 s to 10 s. Solder: Sn-3.0Ag-0.5Cu solder Pre-heating: 150°C±10°C/60 s to 90 s Solder temperature: 270°C±5°C Immersion time: 10 s±1 s Post-treatment: left at a room condition for 24 h±2 h</p>

9. Environmental Performance

The product is soldered on a substrate for test.

No.	Item	Specification	Test method
9.1	Heat resistance	Appearance: No significant mechanical damage shall be observed. Inductance change rate: within ±5% Q change rate: within ±20%	<p>Temperature: 125°C±2°C Test time: 1000 h (+48 h, -0 h) Post-treatment: left at a room condition for 24 h±2 h</p>
9.2	Cold resistance	Appearance: No significant mechanical damage shall be observed. Inductance change rate: within ±5% Q change rate: within ±20%	<p>Temperature: -55°C±2°C Test time: 1000 h (+48 h, -0 h) Post-treatment: left at a room condition for 24 h±2 h</p>
9.3	Humidity	Appearance: No significant mechanical damage shall be observed. Inductance change rate: within ±5% Q change rate: within ±20%	<p>Temperature: 40°C±2°C Humidity: 90% (RH) to 95% (RH) Test time: 1000 h (+48 h, -0 h) Post-treatment: left at a room condition for 24 h±2 h</p>
9.4	Temperature cycle	Appearance: No significant mechanical damage shall be observed. Inductance change rate: within ±5% Q change rate: within ±20%	<p>Single cycle conditions: Step 1: -55°C±2°C/30 min±3 min Step 2: ordinary temperature/10 min to 15 min Step 3: +125°C±2°C/30 min±3 min Step 4: ordinary temperature/10 min to 15 min Number of testing: 10 cycles Post-treatment: left at a room condition for 24 h±2 h</p>

10. Specification of Packaging

10.1 Appearance and dimensions of tape (8 mm width/paper tape)

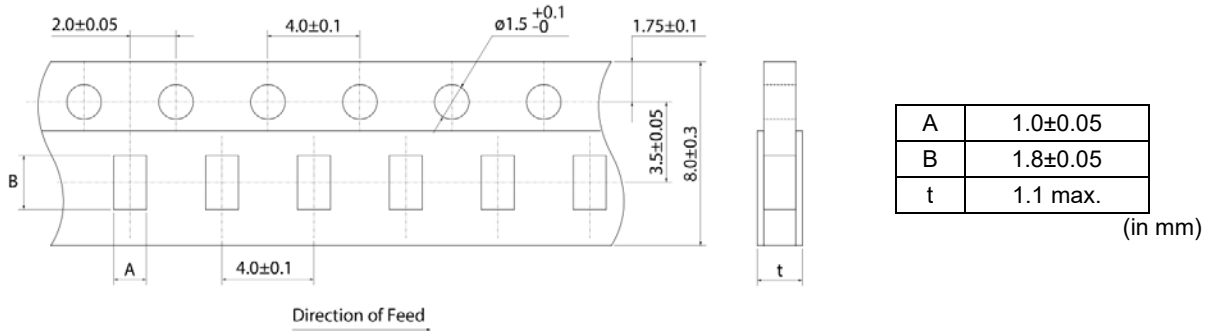

10.2 Taping specifications

Packing quantity (Standard quantity)	4000 pcs/reel
Packing method	The products are placed in embossed cavities of a base tape and sealed by a top tape and a bottom tape.
Feed hole position	The feed holes on the base tape are on the right side when the top tape is pulled toward the user.
Joint	The base tape and the top tape are seamless.
Number of missing products	Number of missing products within 0.1% of the number per reel or 1 pc., whichever is greater, and are not continuous. The specified quantity per reel is kept.

10.3 Break down force of tape

Break down force of top tape	5 N min.
Break down force of bottom tape	5 N min.

10.4 Peeling off force of top tape

Speed of peeling off	300 mm/min
Peeling off force	0.1 N to 0.6 N (The lower limit is for typical value.)

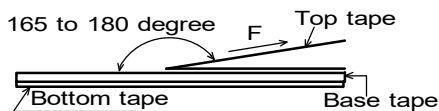

10.5 Dimensions of leader section, trailer section and reel

A vacant section is provided in the leader (start) section and trailer (end) section of the tape for the product. The leader section is further provided with an area consisting only of the top tape. (See the diagram below.)

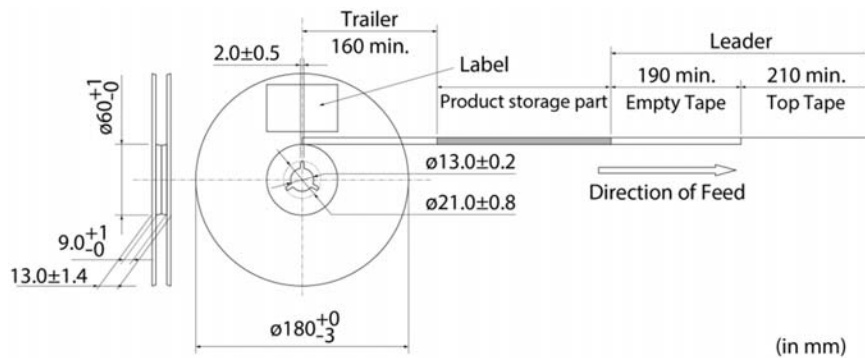

10.6 Marking for reel

Customer part number, Murata part number, inspection number (*1), RoHS marking (*2), quantity, etc.

<p>*1 Expression of inspection No.:</p> <table style="width: 100%; text-align: center; border-collapse: collapse;"> <tr> <td style="border: 1px solid black; padding: 2px;">□□</td> <td style="border: 1px solid black; padding: 2px;">○○○○</td> <td style="border: 1px solid black; padding: 2px;">◇◇◇◇</td> </tr> <tr> <td style="border: none;">(1)</td> <td style="border: none;">(2)</td> <td style="border: none;">(3)</td> </tr> </table>	□□	○○○○	◇◇◇◇	(1)	(2)	(3)	<p>(1) Factory code (2) Date First digit: year/last digit of year Second digit: month/Jan. to Sep.→1 to 9, Oct. to Dec.→O, N, D Third, Fourth digit: day (3) Serial No.</p>
□□	○○○○	◇◇◇◇					
(1)	(2)	(3)					
<p>*2 Expression of RoHS marking:</p> <p>ROHS- $\frac{Y}{(1)}$ $\frac{(\Delta)}{(2)}$</p>	<p>(1) RoHS regulation conformity (2) Murata classification number</p>						

10.7 Marking on outer box (corrugated box)

Customer name, purchasing order number, customer part number, Murata part number, RoHS marking (*2), quantity, etc.

10.8 Specification of outer box

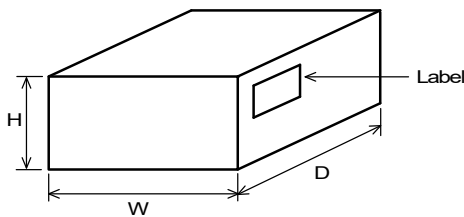

Dimensions of outer box (mm)			Standard reel quantity in outer box (reel)
W	D	H	
186	186	93	5
* Above outer box size is typical. It depends on a quantity of an order.			

11. ⚠Caution

<p>Restricted applications</p>	<p>Please contact us before using our products for the applications listed below which require especially high reliability for the prevention of defects which might directly cause damage to the third party's life, body or property.</p> <table style="width: 100%; border: none;"> <tr> <td style="width: 50%; padding: 2px;">(1) Aircraft equipment</td> <td style="width: 50%; padding: 2px;">(6) Transportation equipment (vehicles, trains, ships, etc.)</td> </tr> <tr> <td style="padding: 2px;">(2) Aerospace equipment</td> <td style="padding: 2px;">(7) Traffic signal equipment</td> </tr> <tr> <td style="padding: 2px;">(3) Undersea equipment</td> <td style="padding: 2px;">(8) Disaster/crime prevention equipment</td> </tr> <tr> <td style="padding: 2px;">(4) Power plant control equipment</td> <td style="padding: 2px;">(9) Data-processing equipment</td> </tr> <tr> <td style="padding: 2px;">(5) Medical equipment</td> <td style="padding: 2px;">(10) Applications of similar complexity and/or reliability requirements to the applications listed in the above</td> </tr> </table>	(1) Aircraft equipment	(6) Transportation equipment (vehicles, trains, ships, etc.)	(2) Aerospace equipment	(7) Traffic signal equipment	(3) Undersea equipment	(8) Disaster/crime prevention equipment	(4) Power plant control equipment	(9) Data-processing equipment	(5) Medical equipment	(10) Applications of similar complexity and/or reliability requirements to the applications listed in the above
(1) Aircraft equipment	(6) Transportation equipment (vehicles, trains, ships, etc.)										
(2) Aerospace equipment	(7) Traffic signal equipment										
(3) Undersea equipment	(8) Disaster/crime prevention equipment										
(4) Power plant control equipment	(9) Data-processing equipment										
(5) Medical equipment	(10) Applications of similar complexity and/or reliability requirements to the applications listed in the above										

12. Precautions for Use

This product is for use only with reflow soldering. It is designed to be mounted by soldering. If you want to use other mounting method, for example, using a conductive adhesive, please consult us beforehand.

12.1 Land dimensions

The following diagram shows the recommended land dimensions for reflow soldering.

The land dimensions are designed in consideration of electrical characteristics and mountability. Use of other land dimensions may preclude achievement of performance. In some cases, it may result in poor solderability, including positional shift. If you use other land pattern, consider it adequately.

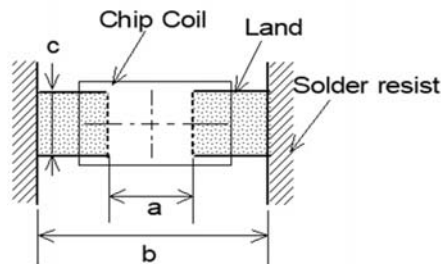

a	0.6 to 0.8
b	1.9 to 2.0
c	0.7 to 1.0
(in mm)	

12.2 Flux and solder used

Flux	<ul style="list-style-type: none"> Use a rosin-based flux that includes an activator with a chlorine conversion value of 0.06(wt)% to 0.1(wt)%. Do not use a highly acidic flux with a halide content exceeding 0.2(wt)% (chlorine conversion value). Do not use a water-soluble flux.
Solder	<ul style="list-style-type: none"> Use Sn-3.0Ag-0.5Cu solder. Standard thickness of solder paste: 100 μm to 150 μm

If you want to use a flux other than the above, please consult our technical department.

12.3 Soldering conditions (reflow)

- Pre-heating should be in such a way that the temperature difference between solder and product surface is limited to 150°C max. Cooling into solvent after soldering also should be in such a way that the temperature difference is limited to 100°C max. Insufficient pre-heating may cause cracks on the product, resulting in the deterioration of product quality.
- Standard soldering profile and the limit soldering profile is as follows. The excessive limit soldering conditions may cause leaching of the electrode and/or resulting in the deterioration of product quality.

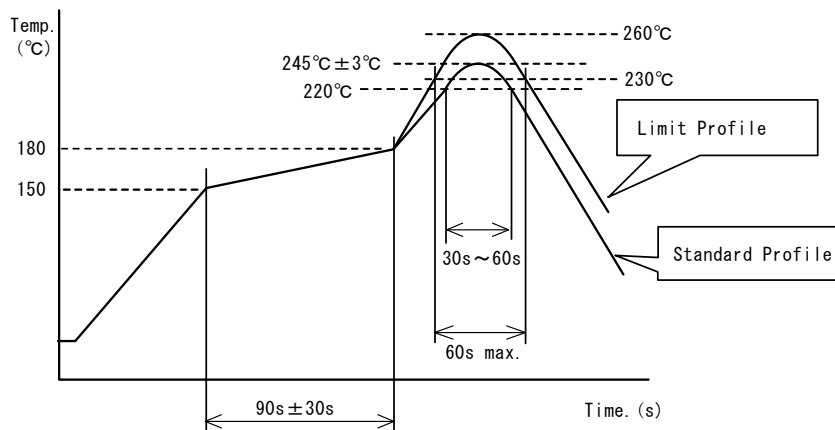

	Standard profile	Limit profile
Pre-heating	150°C to 180°C/90 s ± 30 s	150°C to 180°C/90 s ± 30 s
Heating	Above 220°C/30 s to 60 s	Above 230°C/60 s max.
Peak temperature	245°C ± 3°C	260°C/10 s
Number of reflow cycles	2 times	2 times

12.4 Reworking with soldering iron

The following requirements must be met to rework a soldered product using a soldering iron.

Item	Requirement
Pre-heating	150°C/approx. 1 min
Tip temperature of soldering iron	350°C max.
Power consumption of soldering iron	80 W max.
Tip diameter of soldering iron	ø3 mm max.
Soldering time	3 s (+1 s, -0 s)
Number of reworking operations	2 times max.

* Avoid a direct contact of the tip of the soldering iron with the product. Such a direction contact may cause cracks in the ceramic body due to thermal shock.

12.5 Solder volume

Solder shall be used not to increase the volume too much.

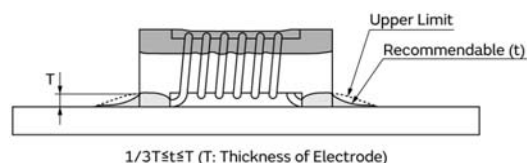

An increased solder volume increases mechanical stress on the product. Exceeding solder volume may cause the failure of mechanical or electrical performance.

12.6 Product's location

The following shall be considered when designing and laying out PCBs.

(1) PCB shall be designed so that products are not subject to mechanical stress due to warping the board.

[Products direction]

Products shall be located in the sideways direction (length: $a < b$) to the mechanical stress.

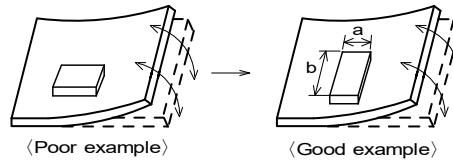

(2) Components location on PCB separation

It is effective to implement the following measures, to reduce stress in separating the board.

It is best to implement all of the following three measures; however, implement as many measures as possible to reduce stress.

Contents of measures	Stress level
(1) Turn the mounting direction of the component parallel to the board separation surface.	$A > D^{*1}$
(2) Add slits in the board separation part.	$A > B$
(3) Keep the mounting position of the component away from the board separation surface.	$A > C$
*1 $A > D$ is valid when stress is added vertically to the perforation as with hand separation. If a cutting disc is used, stress will be diagonal to the PCB, therefore $A > D$ is invalid.	

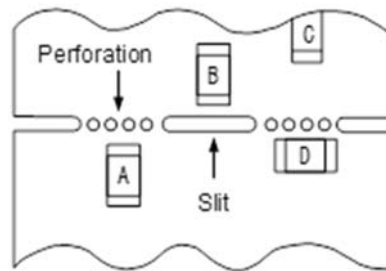

(3) Mounting components near screw holes

When a component is mounted near a screw hole, it may be affected by the board deflection that occurs during the tightening of the screw.

Mount the component in a position as far away from the screw holes as possible.

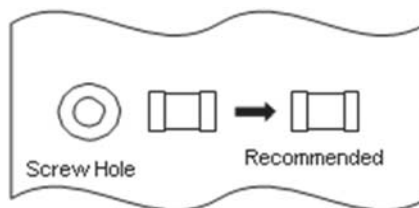

12.7 Handling of substrate

After mounting products on a substrate, do not apply any stress to the product caused by bending or twisting to the substrate when cropping the substrate, inserting and removing a connector from the substrate or tightening screw to the substrate. Excessive mechanical stress may cause cracking in the product.

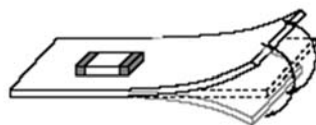

Bending



Twisting

12.8 Cleaning

The product shall be cleaned under the following conditions.

- (1) The cleaning temperature shall be 60°C max. If isopropyl alcohol (IPA) is used, the cleaning temperature shall be 40°C max.
- (2) Perform ultrasonic cleaning under the following conditions. Exercise caution to prevent resonance phenomenon in mounted products and the PCB.

Item	Requirement
Power	20 W/L max.
Time	5 min max.
Frequency	28 kHz to 40 kHz

- (3) Cleaner

Alcohol-based cleaner: IPA

Aqueous agent: PINE ALPHA ST-100S

- (4) There shall be no residual flux or residual cleaner. When using aqueous agent, rinse the product with deionized water adequately and completely dry it so that no cleaner is left.

* For other cleaning, consult our technical department.

12.9 Storage and transportation

Storage period	Use the product within 12 months after delivery. If you do not use the product for more than 12 months, check solderability before using it.
Storage conditions	<ul style="list-style-type: none"> • The products shall be stored in a room not subject to rapid changes in temperature and humidity. The recommended temperature range is -10°C to +40°C. The recommended relative humidity range is 15% to 85%. • Keeping the product in corrosive gases, such as sulfur, chlorine gas or acid, oxidizes the electrode, resulting in poor solderability or corrosion of the coil wire of the product. • Do not keep products in bulk packaging. Doing so may cause collision between the products or between the products and other products, resulting in core chipping or wire breakage. • Do not place the products directly on the floor; they should be placed on a palette so that they are not affected by humidity or dust. • Avoid keeping the products in a place exposed to direct sunlight, heat or vibration.
Transportation	Excessive vibration and impact reduces the reliability of the products. Exercise caution when handling the products.

12.10 Resin coating

The inductance value may change due to high cure-stress of resin to be used for coating/molding products.

A wire breakage issue may occur by mechanical stress caused by the resin, amount/cured shape of resin, or operating condition etc. Some resin contains some impurities or chloride possible to generate chlorine by hydrolysis under some operating condition may cause corrosion of wire of coil, leading to wire breakage.

So, please pay your careful attention when you select resin in case of coating/molding the products with the resin.

Prior to use the coating resin, please make sure no reliability issue is observed by evaluating products mounted on your board.

12.11 Handling of product

- Sharp material such as a pair of tweezers or other material such as bristles of cleaning brush, shall not be touched to the winding portion to prevent the breaking of wire.
- Mechanical shock should not be applied to the products mounted on the board to prevent the breaking of the core.

12.12 Handling with mounting equipment

- With some types of mounting equipment, a support pin pushes up the product from the bottom of the base (paper) tape when the product is sucked with the pick-up nozzle.
When using this type of equipment, detach the support pin to prevent the breaking of wire on the product.
- In some cases, the laser recognition function of the mounting equipment may not recognize this product correctly. Please contact us when using laser recognition. (There is no problem with the permeation and reflection type.)

13. ⚠Note

- (1) Please make sure that your product has been evaluated in view of your specifications with our product being mounted to your product.
- (2) You are requested not to use our product deviating from the reference specifications.
- (3) The contents of this reference specification are subject to change without advance notice. Please approve our product specifications or transact the approval sheet for product specifications before ordering.

14. Appendix

Electrical performance: Measuring method for inductance/Q (Q measurement is applicable only when the Q value is included in the rating table.)

Perform measurement using the method described below. (Perform correction for the error deriving from the measuring terminal.)

(1) Residual elements and stray elements of the measuring terminal can be expressed by the F parameter for the 2-pole terminal as shown in the figure below.

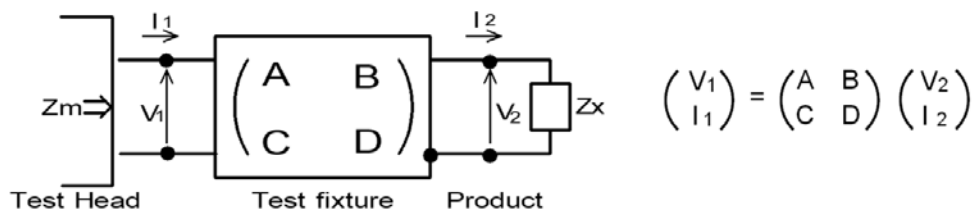

(2) The product's impedance value (Z_x) and measured impedance value (Z_m) can be expressed as shown below, by using the respective current and voltage for input/output.

$$Z_m = \frac{V_1}{I_1} \quad Z_x = \frac{V_2}{I_2}$$

(3) Thus, the relationship between the product's impedance value (Z_x) and measured impedance value (Z_m) is as follows.

$Z_x = \alpha \frac{Z_m - \beta}{1 - Z_m \Gamma}$	<p>Here,</p> <p>$\alpha = D/A = 1$</p> <p>$\beta = B/D = Z_{sm} - (1 - Y_{om} Z_{sm}) Z_{ss}$</p> <p>$\Gamma = C/A = Y_{om}$</p> <p>$Z_{sm}$: measured impedance of short chip</p> <p>Z_{ss}: residual impedance of short chip (0.771 nH)</p> <p>Y_{om}: measured admittance when measuring terminal is open</p>
---	--

(4) Calculate inductance L_x and Q_x using the equations shown below.

$L_x = \frac{\text{Im}(Z_x)}{2\pi f}$	<p>L_x: inductance of chip coil</p> <p>Q_x: Q of chip coil</p> <p>f: measuring frequency</p>
$Q_x = \frac{\text{Im}(Z_x)}{\text{Re}(Z_x)}$	

Mouser Electronics

Authorized Distributor

Click to View Pricing, Inventory, Delivery & Lifecycle Information:

Murata:

[LQW18AN10NG00D](#) [LQW18AN10NJ00D](#) [LQW18AN11NG00D](#) [LQW18AN11NJ00D](#) [LQW18AN12NG00D](#)
[LQW18AN12NJ00D](#) [LQW18AN13NG00D](#) [LQW18AN13NJ00D](#) [LQW18AN15NG00D](#) [LQW18AN15NJ00D](#)
[LQW18AN16NG00D](#) [LQW18AN16NJ00D](#) [LQW18AN18NG00D](#) [LQW18AN18NJ00D](#) [LQW18AN20NG00D](#)
[LQW18AN20NJ00D](#) [LQW18AN22NG00D](#) [LQW18AN22NJ00D](#) [LQW18AN24NG00D](#) [LQW18AN24NJ00D](#)
[LQW18AN27NG00D](#) [LQW18AN27NJ00D](#) [LQW18AN2N2D00D](#) [LQW18AN30NG00D](#) [LQW18AN30NJ00D](#)
[LQW18AN33NG00D](#) [LQW18AN33NJ00D](#) [LQW18AN36NG00D](#) [LQW18AN36NJ00D](#) [LQW18AN39NG00D](#)
[LQW18AN39NJ00D](#) [LQW18AN3N6C00D](#) [LQW18AN3N6D00D](#) [LQW18AN3N9C00D](#) [LQW18AN3N9D00D](#)
[LQW18AN43NG00D](#) [LQW18AN43NJ00D](#) [LQW18AN47NG00D](#) [LQW18AN47NJ00D](#) [LQW18AN4N3C00D](#)
[LQW18AN4N3D00D](#) [LQW18AN4N7D00D](#) [LQW18AN51NG00D](#) [LQW18AN51NJ00D](#) [LQW18AN56NG00D](#)
[LQW18AN56NJ00D](#) [LQW18AN5N6C00D](#) [LQW18AN5N6D00D](#) [LQW18AN62NG00D](#) [LQW18AN62NJ00D](#)
[LQW18AN68NG00D](#) [LQW18AN68NJ00D](#) [LQW18AN6N2C00D](#) [LQW18AN6N2D00D](#) [LQW18AN6N8C00D](#)
[LQW18AN6N8D00D](#) [LQW18AN72NG00D](#) [LQW18AN72NJ00D](#) [LQW18AN75NG00D](#) [LQW18AN75NJ00D](#)
[LQW18AN7N5D00D](#) [LQW18AN82NG00D](#) [LQW18AN82NJ00D](#) [LQW18AN8N2D00D](#) [LQW18AN8N7D00D](#)
[LQW18AN91NG00D](#) [LQW18AN91NJ00D](#) [LQW18AN9N1D00D](#) [LQW18AN9N5D00D](#) [LQW18ANR10G00D](#)
[LQW18ANR10J00D](#) [LQW18ANR11G00D](#) [LQW18ANR11J00D](#) [LQW18ANR12G00D](#) [LQW18ANR12J00D](#)
[LQW18ANR13G00D](#) [LQW18ANR13J00D](#) [LQW18ANR15G00D](#) [LQW18ANR15J00D](#) [LQW18ANR16G00D](#)
[LQW18ANR16J00D](#) [LQW18ANR18G00D](#) [LQW18ANR18J00D](#) [LQW18ANR20G00D](#) [LQW18ANR20J00D](#)
[LQW18ANR22G00D](#) [LQW18ANR22J00D](#) [LQW18ANR27G00D](#) [LQW18ANR27J00D](#) [LQW18ANR33G00D](#)
[LQW18ANR33J00D](#) [LQW18ANR39G00D](#) [LQW18ANR39J00D](#) [LQW18ANR47G00D](#) [LQW18ANR47J00D](#)
[LQW18AN9N1C00D](#) [LQW18AN8N7C00D](#) [LQW18AN7N5C00D](#) [LQW18AN8N2C00D](#)