

# Product Specification

## A087/ Low Profile Stainless Steel Base and Stud Levelling Foot Range

- Materials**
- Base** Stainless Steel type
- 303 with Inset Nitrile Rubber Pad
- Stud** Stainless Steel type
- 303



Part No.	Thread Size D1 (mm)	Thread Length L (mm)	Base Diameter D2 (mm)	Overall Height H (mm)	Max Load (kg)
A087 / 001	M12	75	55	102	750
A087 / 002	M12	125	55	152	750
A087 / 003	M12	150	55	177	750
A087 / 004	M16	75	65	108	1250
A087 / 005	M16	125	65	158	1250
A087 / 006	M16	150	65	183	1250

A087 / 010	M20	125	75	166	1750
A087 / 011	M20	150	75	191	1750
A087 / 012	M20	200	75	241	1750
A087 / 016	M24	125	100	177	2500
A087 / 017	M24	150	100	202	2500
A087 / 018	M24	200	100	252	2500

Dimensions are approximate

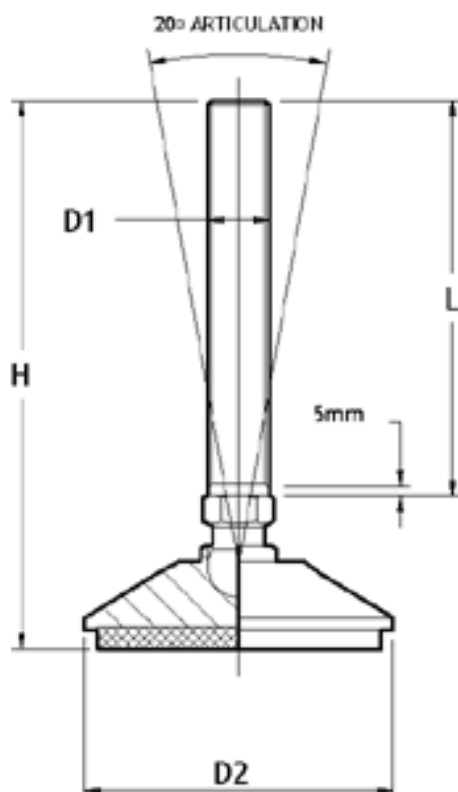

### General

The Levelling Feet are suitable for use in a wide range of Industries such as:-

Food Processing,  
Medical, Dairy,  
Electronic, Laser  
Robotics and Laboratory  
Machinery/Equipment.

### Applications include:-

Conveyors, Weighing  
Machines, Food, Drink  
and Pharmaceutical  
Processing Equipment,  
Packaging Machinery,  
Heavy Duty Machine  
Tools and Special

Purpose Machines.

**Options  
Available**

**Hygienic Seal:**

Provides a flexible cover over the ball and socket arrangement.