

Datasheet

Art.No. 07.313.2655.0

Partition

Partition plate for DIN rail terminal block type WT 2,5 - WT 10, color gray



Art.No.	07.313.2655.0
EAN	4049088168024
Order unit	10 pieces

Approvals

Technical data

General

Colour	Grey
Type of end plate	No
Type of partition	Yes
Thickness	2 mm
Snap in	Yes
Inflammability class of insulation material acc. with UL94	V0

Accessories

Type of end plate	No
Type of partition	Yes
Colour	Grey
Thickness	2 mm
Snap in	Yes
Inflammability class of insulation material acc. with UL94	V0

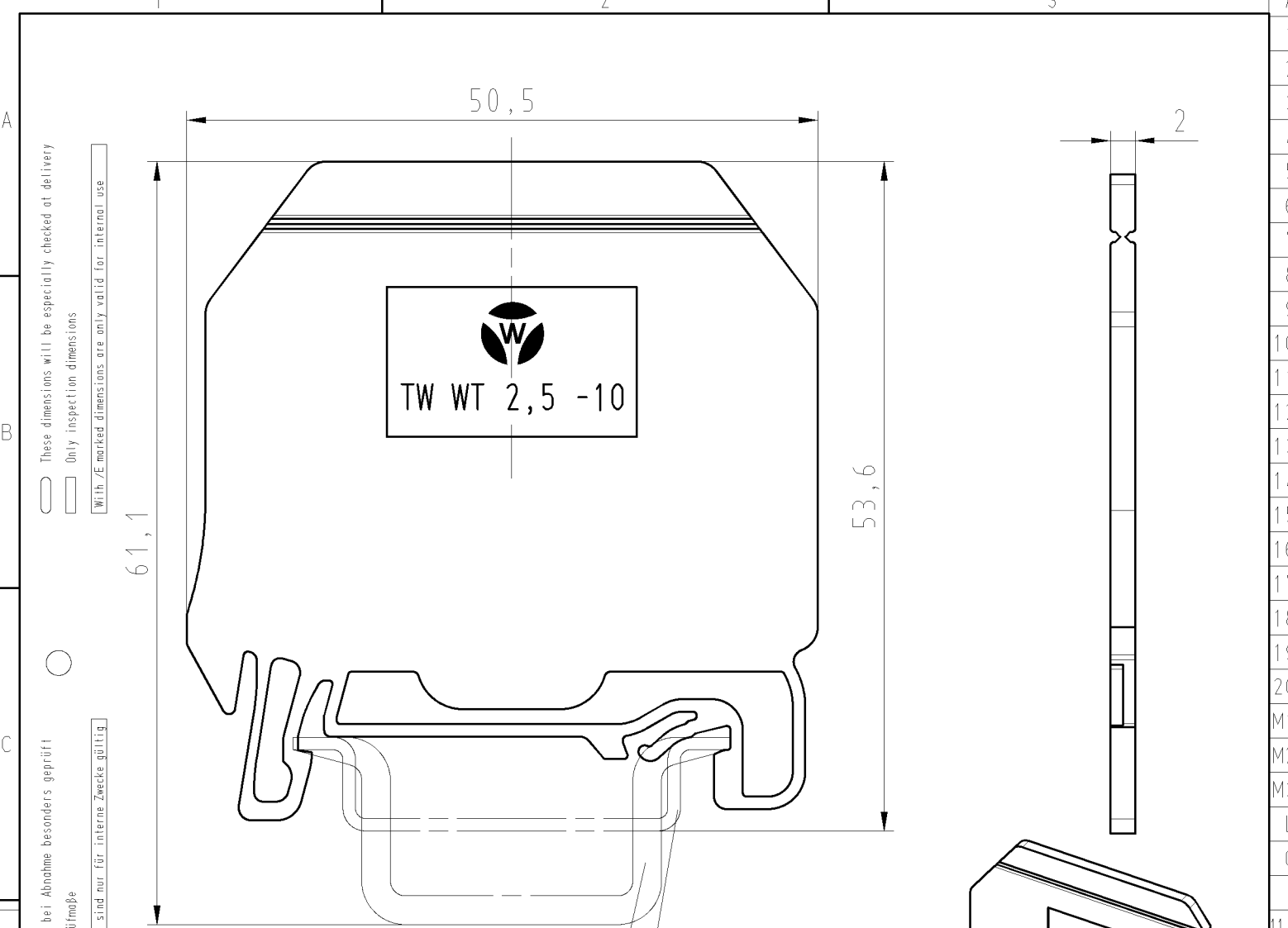

These dimensions will be especially checked at delivery
 Only inspection dimensions
 With /E marked dimensions are only valid for internal use

Diese Maße werden bei Abnahme besonders geprüft
 Ausschließlich Prüfmaße
 Mit /E gekennzeichnete Maße sind nur für interne Zwecke gültig

Hutschiene EN 60715-35x7,5
 mounting rail EN 60715-35x7,5

Hutschiene EN 60715-35x15
 mounting rail EN 60715-35x15

M/scale 1:1

Weitere Daten siehe Katalog further data see catalog	Teile-Nr. part-no.	Farbe color	Type type
	07.313.2655.0	grau, ähnl. RAL 7032 grey, similar to RAL 7032	W WT 2,5 - 10 GR
	07.313.2655.1	schwarz, ähnl. RAL 9005 black, similar to RAL 9005	W WT 2,5 - 10 SW

Tolerierung Size ISO 14405 (Tolerance system Size ISO 14405)
 (This ISO-standard describes the envelope principle. According to the envelope principle the deviations of form and parallelism are limited by the size tolerances).

ja/yes Stoffverbots- und Deklarationsliste nach UU-TQM-05/03 ist einzuhalten.
 Conformity with Wieland document UU-TQM-05/03 (list of prohibited / declarable hazardous substances) to be declared!

Freitoleranz nach General tolerance
 CAD - Zeichnung, keine manuellen Änderungen CAD - drawing, no manual modifications allowed
 1. Verwendung: - First Use:
 Blatt: 1 von 1 Sheet: 1 of 1

Werkstoff/Material 2013 Tag/Date Name gezeichnet drawn 14.01 Eller geprüft checked - - Normgepr. Stand. check - -	Zeichnung Nr./Drawing No. T 07.313.2655.0 01K	Index
Maße in mm/Dimensions are in mm		

Vol. 2694 mm³ Ofl./Surf. 5976 mm² Ersatz für/Replacement for: -	Type wieland Elektrische Verbindungen	Benennung/Title TRENNWAND_2_5_10 partition plate für/for WT 2,5 - 10
Index Datum / Blatt Date / Sheet Änderung/Revision		

A 1 2 3 4 5 6 7 8 9 10 11 12 13 14 15 16 17 18 19 20 M1 M2 M3 L G i 11.1 12.1 1.1 073132655001K_2 CADW3070 U0016728 2013-01-15 11:04:14 1.000