

Air preparation unit, 2-part, Series NL4-ACD

0821300500

General series information
AVENTICS Series NL4 Air Preparation Units

- The AVENTICS Series NL maintenance units are suitable for all areas: as individual components or as assembled maintenance units, for centralized or decentralized compressed air preparation, in compact or powerful versions, for use in high or low temperatures. This line offers a complete, customizable compressed air preparation technology. It includes an option to combine every component in the Series to achieve the desired function, making it possible to adjust the components precisely to the application requirements.

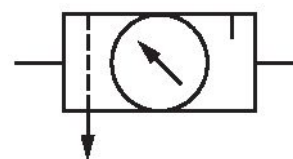

Technical data

Industry
Parts

Reservoir

Port

Nominal flow Qn

Filter porosity

Condensate drain

Pressure gauge

Working pressure min.

Working pressure max

Min. ambient temperature

Max. ambient temperature

Regulation range min.

Regulation range max.

Industrial

Air preparation units

Filter pressure regulator

Lubricator

reservoir, polycarbonate, without protective guard

G 1/2

5000 l/min

5 µm

semi-automatic, open without pressure

with pressure gauge

1.5 bar

16 bar

-10 °C

60 °C

0.5 bar

10 bar

Lock type	not lockable
Type	2-part
Type	Can be assembled into blocks
Pressure supply	single
Mounting orientation	vertical
Regulator type	Diaphragm-type pressure regulator
Regulator function	with relieving air exhaust
Filter element	exchangeable
Filter reservoir volume	50 cm ³
Max. achievable compressed air class acc. to ISO 8573-1:2010	6 : 7 : -
Lubricator reservoir volume	125 cm ³
Type of filling	Manual oil filling
Medium	Compressed air Neutral gases
Weight	1.73 kg

Material

Housing material	Die cast zinc
Seal material	Acrylonitrile butadiene rubber
Material front plate	Acrylonitrile butadiene styrene
Material threaded bushing	Die cast zinc
Material reservoir	Polycarbonate
Material filter insert	Polyethylene
Part No.	0821300500

Technical information

The pressure dew point must be at least 15 °C under ambient and medium temperature and may not exceed 3 °C .

Note: Polycarbonate reservoirs are susceptible to solvents, supplementary information can be found at "Customer information".

A change in the flow direction (from air supply on the left to air supply on the right) occurs by rotating installation by 180° about the vertical axis. Please see the operating instructions for further details.

Also suitable for separation of fluid oil or water due to the design.

Nominal flow Q_n with secondary pressure p₂ = 6 bar at Δp = 1 bar

Metal protective guard can be retrofitted for all polycarbonate reservoirs

Dimensions

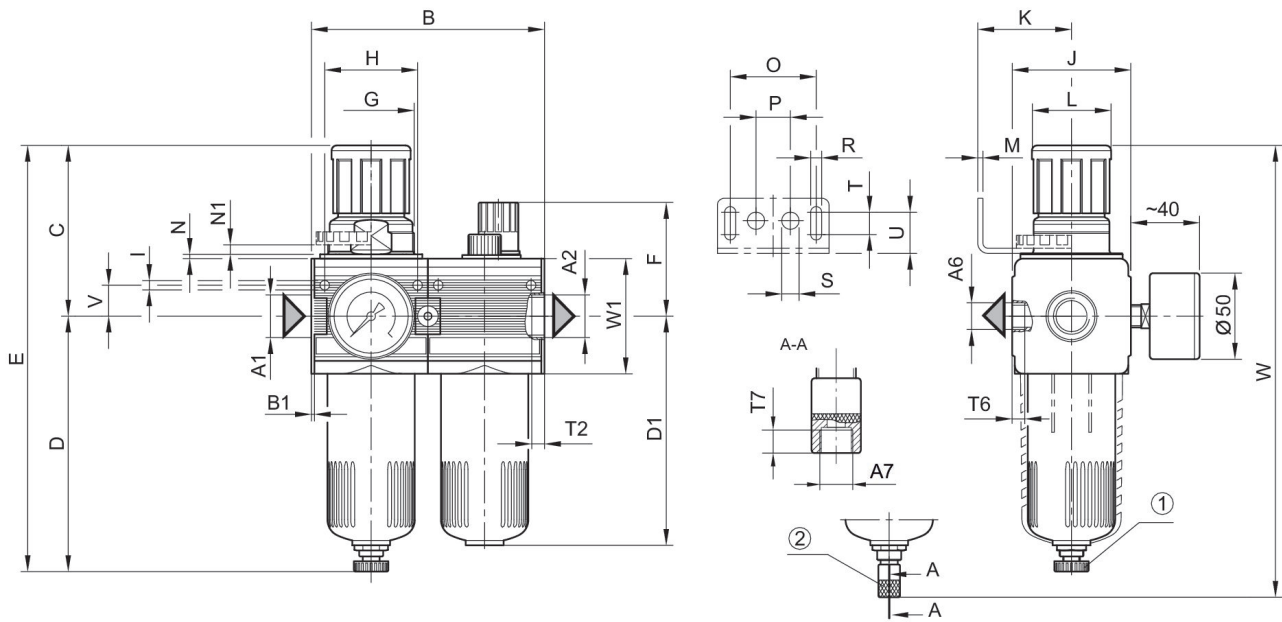

A1 = input A2 = output
A7 = condensate drain
1) Semi-automatic condensate drain 2) fully automatic condensate drain

Dimensions in mm

Part No.	A1	A2	A6	A7	B	B1	C	D	D1
0821300500	G 1/2	G 1/2	G 1/4	G 1/8	135.6	1.8	100.5	147	132
0821300503	G 1/2	G 1/2	G 1/4	G 1/8	135.6	1.8	100.5	147	132
0821300501	G 1/2	G 1/2	G 1/4	G 1/8	135.6	1.8	100.5	147	132
0821300504	G 1/2	G 1/2	G 1/4	G 1/8	135.6	1.8	100.5	147	132
0821300502	G 1/2	G 1/2	G 1/4	G 1/8	135.6	1.8	100.5	147	132
0821300505	G 1/2	G 1/2	G 1/4	G 1/8	135.6	1.8	100.5	147	132
0821300530	G 3/4	G 3/4	G 1/4	G 1/8	135.6	1.8	100.5	147	132
0821300533	G 3/4	G 3/4	G 1/4	G 1/8	135.6	1.8	100.5	147	132
0821300531	G 3/4	G 3/4	G 1/4	G 1/8	135.6	1.8	100.5	147	132
0821300534	G 3/4	G 3/4	G 1/4	G 1/8	135.6	1.8	100.5	147	132
0821300532	G 3/4	G 3/4	G 1/4	G 1/8	135.6	1.8	100.5	147	132
0821300535	G 3/4	G 3/4	G 1/4	G 1/8	135.6	1.8	100.5	147	132

Part No.	E	F	G	H	I	J	K	L	M
0821300500	247.5	65	M50x1,5	54	5.5	69	54.5	46	3
0821300503	247.5	65	M50x1,5	54	5.5	69	54.5	46	3
0821300501	247.5	65	M50x1,5	54	5.5	69	54.5	46	3
0821300504	247.5	65	M50x1,5	54	5.5	69	54.5	46	3
0821300502	247.5	65	M50x1,5	54	5.5	69	54.5	46	3
0821300505	247.5	65	M50x1,5	54	5.5	69	54.5	46	3
0821300530	247.5	65	M50x1,5	54	5.5	69	54.5	46	3

Part No.	E	F	G	H	I	J	K	L	M
0821300533	247.5	65	M50x1,5	54	5.5	69	54.5	46	3
0821300531	247.5	65	M50x1,5	54	5.5	69	54.5	46	3
0821300534	247.5	65	M50x1,5	54	5.5	69	54.5	46	3
0821300532	247.5	65	M50x1,5	54	5.5	69	54.5	46	3
0821300535	247.5	65	M50x1,5	54	5.5	69	54.5	46	3

Part No.	N	N1	O	P	R	S	T	T2	T6
0821300500	3	5.5	50	20	6.4	10	13	13	7
0821300503	3	5.5	50	20	6.4	10	13	13	7
0821300501	3	5.5	50	20	6.4	10	13	13	7
0821300504	3	5.5	50	20	6.4	10	13	13	7
0821300502	3	5.5	50	20	6.4	10	13	13	7
0821300505	3	5.5	50	20	6.4	10	13	13	7
0821300530	3	5.5	50	20	6.4	10	13	13	7
0821300533	3	5.5	50	20	6.4	10	13	13	7
0821300531	3	5.5	50	20	6.4	10	13	13	7
0821300534	3	5.5	50	20	6.4	10	13	13	7
0821300532	3	5.5	50	20	6.4	10	13	13	7
0821300535	3	5.5	50	20	6.4	10	13	13	7

Part No.	T7	U	V	W	W1
0821300500	8.5	24	18	262.5	67
0821300503	8.5	24	18	262.5	67
0821300501	8.5	24	18	262.5	67
0821300504	8.5	24	18	262.5	67
0821300502	8.5	24	18	262.5	67
0821300505	8.5	24	18	262.5	67
0821300530	8.5	24	18	262.5	67
0821300533	8.5	24	18	262.5	67
0821300531	8.5	24	18	262.5	67
0821300534	8.5	24	18	262.5	67
0821300532	8.5	24	18	262.5	67
0821300535	8.5	24	18	262.5	67

Flow rate characteristic, $p_2 = 0,05 - 7$ bar

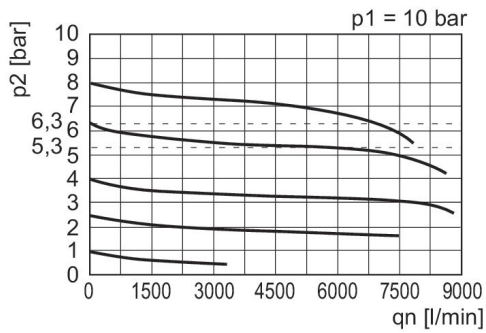

p_1 = Working pressure p_2 = Secondary pressure q_n = Nominal flow

minimum flow rate curve (flow rate necessary for the correct functioning of the lubricator)

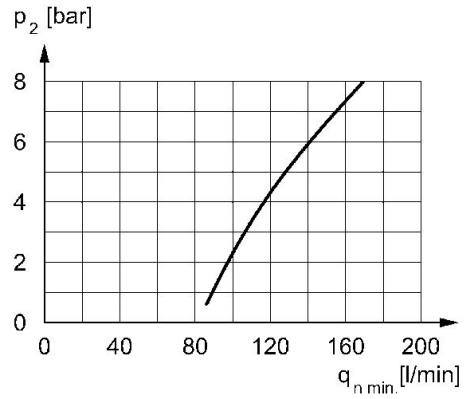

p_1 = operating pressure p_2 = secondary pressure q_n = nominal flow $q_{n \text{ min.}}$ = min. nominal flow