

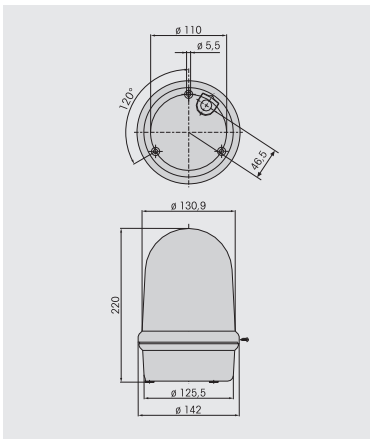

Plastic bracket (accessory)



Flange for tube mounting and wire guard (accessories)



- Extremely high light intensity of more than 185 cd
- Intense double flash with low power consumption
- High flash power from two consecutive flashes
- High impact resistance to 20 Joules

TECHNICAL SPECIFICATIONS:

Life duration up to 50,000 hrs

Dimensions (Diameter x Height):	142 mm x 220 mm
Housing:	PC/ABS-Blend
Dome:	PC, transparent
Fixing:	Base mounting, bracket mounting (accessory), tube mounting (accessory)
Connection:	Screwable conn. with wire protection max. 2.5 mm ² Contact protection according to VDE
Cable entry:	Cable diameter 5 - 7 mm
Life duration:	up to 50,000 hrs
Duty cycle:	100 % ED

ORDER SPECIFICATIONS:

Voltage	24 V [≡]	115-230 V [~]
Current consumption	< 150 mA	< 100 mA
red	280 150 55	280 150 60
yellow	280 350 55	280 350 60
clear	280 450 55	280 450 60

Available: 1st Quarter 2010 (115-230 V version).

ACCESSORIES:

Plastic bracket for wall mounting	975 883 06
Flange for tube mounting max. 25.3 mm	975 883 02
Wire guard	975 883 08



Two consecutive flashes generate brilliant signal

