

Product Specification

深圳市臺華達科技有限公司

SHENZHENSHI THD Electronics Co., Ltd.

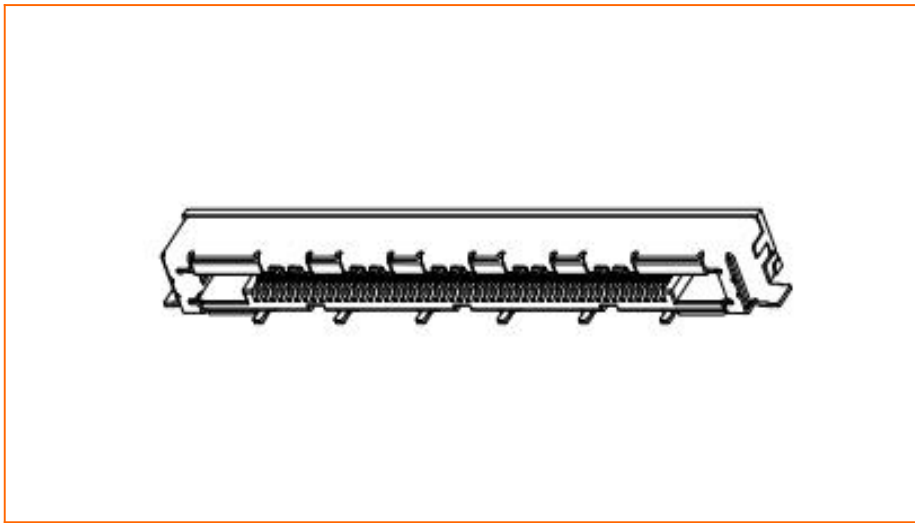

Product.No

THD-LVDS – 51R – GF

Pitch=0.5mm LVDS Connector (Front-Flip Lower Contact)

A	Release
Rev.	Description
Approved Signatures	
■Prepared By : JIM	■Date: 2012.05.24
■Checked By : JIM	■Date: 2012.05.24
■Approved By : 黄德进	■Date: 2012.05.24

■ Scope

This specification covers the 0.5mm Pitch LVDS Connector **THDLVDS** series.

■ Ordering information

THD-LVDS - 51 R - GF

① ② ③ ④

①	Series name : THDLVDS	④	Plating : GF= 1μ"~3μ" Gold Flash G3= 3μ" Gold over Nickel G5= 5μ" Gold over Nickel SN= Tin(Lead Free) over Nickel
②	Number of contacts : 51		
③	PIN		

■ Rating

Item	Standard
Voltage Rating(Max.)	250V AC
Current Rating(Max.)	0.5A DC
Operating Temperature Range	-25°C ~ +85°C (Including terminal temperature rise)

■ Material

Housing	Actuator	Terminal	Solder pin	SHELL
L.C.P (UL94V-0)	L.C.P (UL94V-0)	Copper alloy	Copper alloy	Copper alloy

■ Performance

Item	Test Condition	Specification	
Contact Resistance	Mate applicable FPC and measure by dry circuit, 20mV Max, 1mA.	30 mΩ Max.	
Insulation Resistance	Mate applicable FPC and apply 500V DC between adjacent terminal or ground.	100 MΩ Min.	
Dielectric Strength	Mate applicable FPC, apply 250V AC(rms) for 1 minute between adjacent terminal or ground.	No Breakdown	
FPC Retention Force	Insert the actuator, pull the FPC at a rate of 25±3mm per minute.	Per pin 0.08N MAX.	
Terminal Retention Force	Apply axial pull out force at the rate of 25±3 mm/minute on the terminal assembled in the housing.	Per pin x 0.1Kgf {0.8N} Min.	
Vibration	Mate connectors and subject to the following vibration conditions, for period of 2 hours in each of 3 mutually perpendicular axes, passing DC 1mA during the test. Amplitude : 1.5mm P-P Frequency : 10~55~10 Hz in 1 minute. Duration : 2 hours in each of X,Y,Z axes.	Appearance	No Damage
		Contact Resistance	100 mΩ Max.
		Discontinuity	1 μsec Max.
Shock	Mate applicable FPC and subject to the following shock conditions. 3 times of shocks shall be applied for each 6 directions along 3 mutually perpendicular axes, passing DC 1 mA current during the test. Peak value : 490m/s ² {50G}	Appearance	No Damage
		Contact Resistance	100 mΩ Max.
		Discontinuity	1 μsec Max.
Salt Spray	Mate applicable FPC and expose to the following salt mist conditions. Upon completion of the exposure period, salt deposits shall be removed by a gentle wash or dip in running water, after which the specified measurements shall be performed. NaCl solution Concentration : 5 ± 1% Spray time : 48 ± 4 hours Ambient temperature : 35 ± 2°C	Appearance	No Damage
		Contact Resistance	100 mΩ Max.

Item	Test Condition	Specification	
Heat Resistance	Mate applicable FPC and expose to 85±2°C for 96 hours. Upon completion of the exposure period, the test specimens shall be conditioned at ambient room conditions for 1 to 2 hours, after which the specified measurements shall be performed.	Appearance	No Damage
		Contact Resistance	100 mΩ Max.
Cold Resistance	Mate applicable FPC and expose to -40±2°C for 96 hours. Upon completion of the exposure period, the test specimens shall be conditioned at ambient room conditions for 1 to 2 hours, after which the specified measurements shall be performed.	Appearance	No Damage
		Contact Resistance	100 mΩ Max.
Humidity	Mate applicable FPC and expose to 60 ± 2°C, relative humidity 90 to 95% for 96 hours. Upon completion of the exposure period, the test specimens shall be conditioned at ambient room conditions for 1 to 2 hours, after which the specified measurements shall be performed.	Appearance	No Damage
		Contact Resistance	100 mΩ Max.
		Dielectric Strength	No Breakdown
		Insulation Resistance	50 MΩ Min.
Temperature Rise	Mate applicable FPC and measure the temperature rise of contact when the maximum AC rated current is passed.	Temperature rise	30°C Max.
Temperature Cycling	Mate applicable FPC and subject to the following conditions for 5 cycles. Upon completion of the exposure period, the test specimens shall be conditioned at ambient room conditions for 1 to 2 hours, after which the specified measurements shall be performed. 1 cycle a) -55±3°C 30minutes b) +85±3°C 30minutes (Transit time shall be with in 3 minutes)	Appearance	No Damage
		Contact Resistance	100 mΩ Max.
Solderability	Tip of solder tails and fitting nails into the molten solder (held at 245±5°C) up to 0.1mm from the bottom of the housing for 3±0.5 seconds.	Solder Wetting	95% of immersed area must show no voids, pin holes.
Resistance to Soldering	When reflowing refer to Infrared reflow condition <u>Soldering iron method</u> 0.2mm from terminal tip and fitting nail tip. Soldering time : 5 seconds Max. Solder temperature : 370~400°C	Appearance	No Damage

■ Recommended Temperature Profile

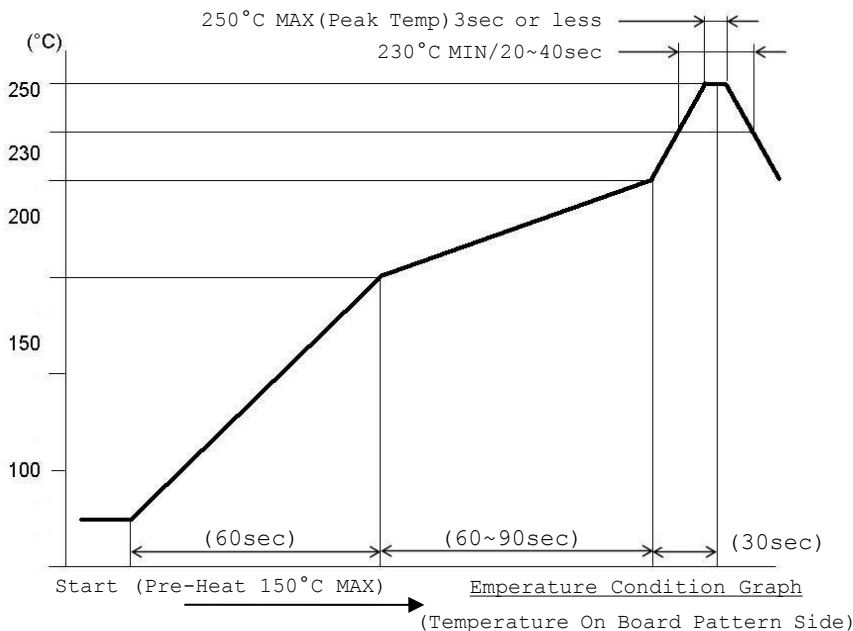

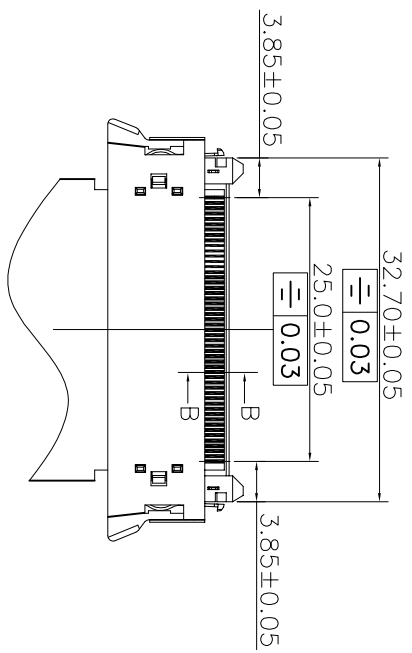
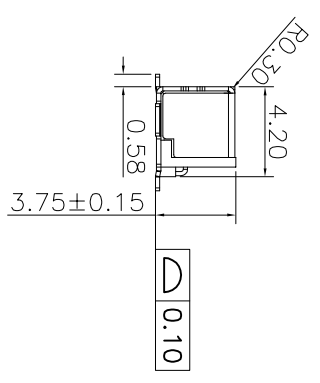
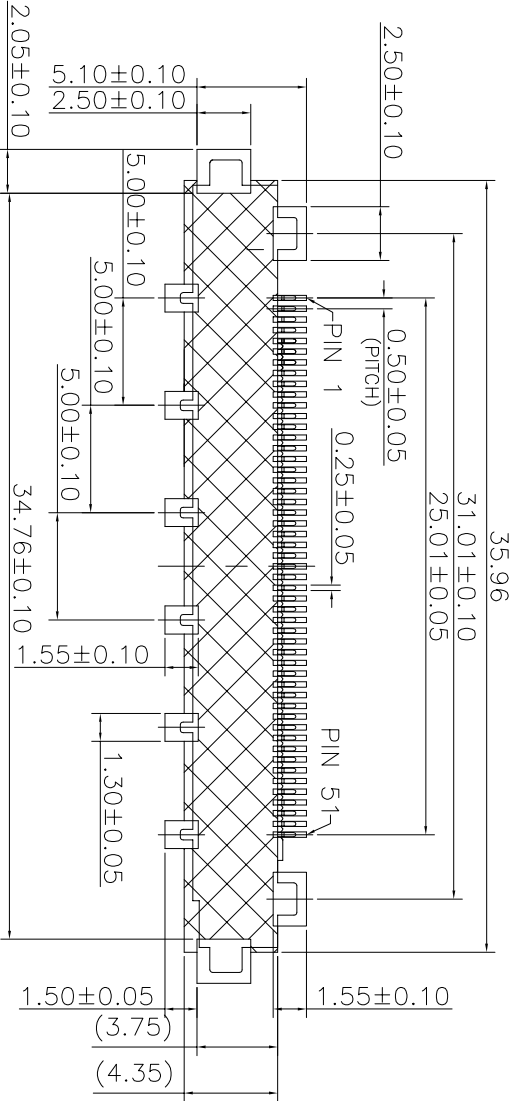
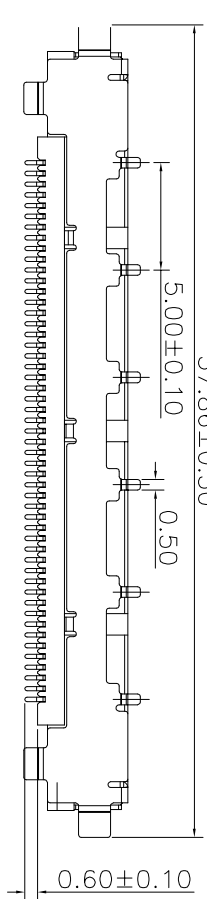
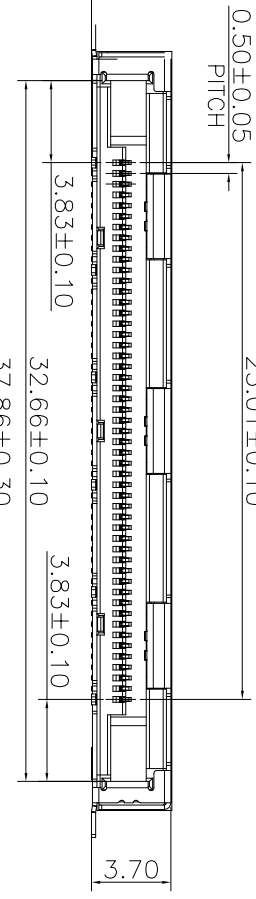
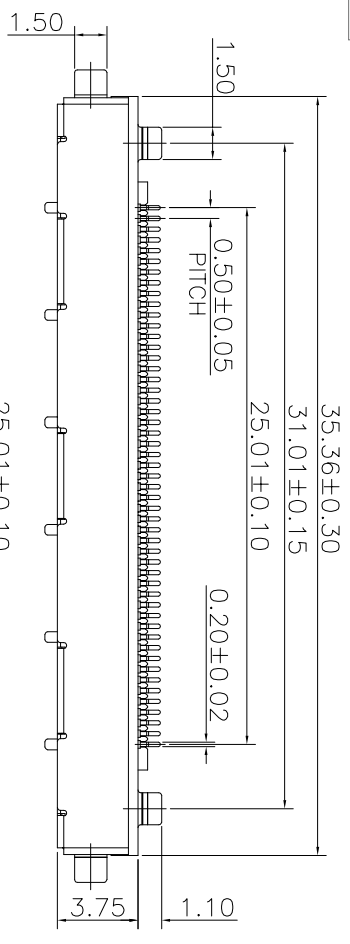

RECOMMENDED LVDS FFC DIM.

SECTION B-B

- NOTES:
- 1.HOUSING: LCP HIGH-TEMP THERMOPLASTIC UL94V-0 COLOR:BLACK
 - 2.TERMINAL:PHOSPHOR BRONZE
 - PLATING:50U" MIN NICKEL ALL OVER 100U"MIN Tin ON SOLDER AREA
 - 1U"GOLD FLASH ON CONTACT AREA
 - 3.SHELL:STAINLESS STEEL
 - PLATING:100~150U" TIN(LEAD FREE)
 - OVERALL 50~100U" NICKEL UNDER PLATED.

- 4.SPECIFICATION:
- CURRENT RATING: 0.5A 50V AC/DC
 - CONTACT RESISTANCE: 40mΩ MAX
 - INSULATION RESISTANCE: 100MΩ AT 500V DC
 - OPERATING TEMPERATURE RANGE: -55°C~+85°C
 - WITHSTANDING VOLTAGE: 250V AC/minute
- 5.CODING INFORMATION: THD-LVDS-51R-GF

NO. OF CONTACTS
0.5PITCH 3.75H R/A SMT Connector
TAIHUADA CONNECTOR SERIES

RECOMMEND P.C.B LAYOUT

CUSTOMER 深圳市壹華達科技有限公司 SHENZHENSHI THD TECHNOLOGY CO., LTD.		DRAWN: Kavin CHECKED: 胡文 APPROVED: 黃德進	PART NO.: THD-LVDS-51R-GF TITLE: 0.5PITCH 3.75H LVDS CONTACT R/A SMT CONN.
GENERAL TOLERANCE UNLESS OTHERWISE SPECIFIED XX ±0.25 XXX ±0.20 XXXX ±0.15 ANG. ±2°		DATE: 2012.04.30 SHEET: 1/2 UNIT: mm SCALE: 1:1 SIZE: A4 REV: X1	SHEET: 1/2 UNIT: mm SCALE: 1:1 SIZE: A4 REV: X1
REV.	REVISIONS	CHK	DATE

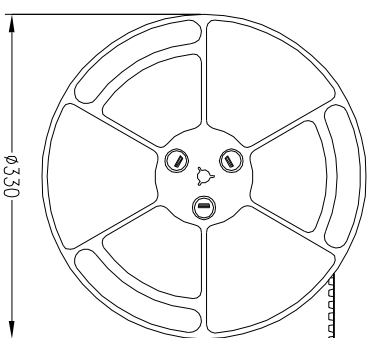
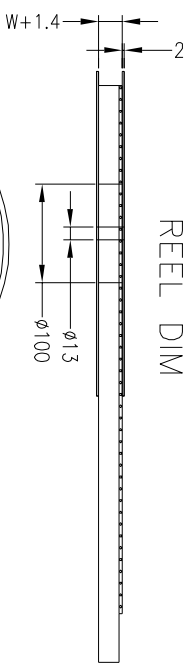
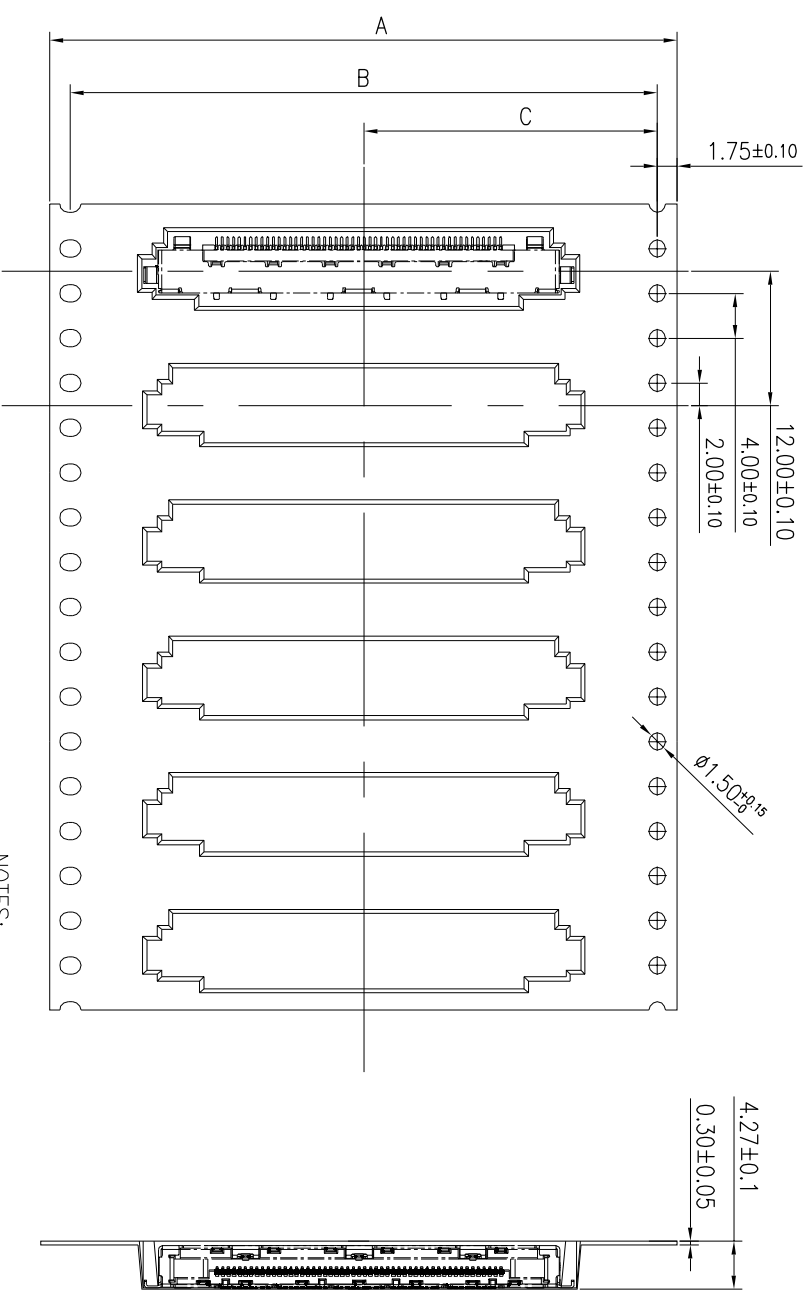
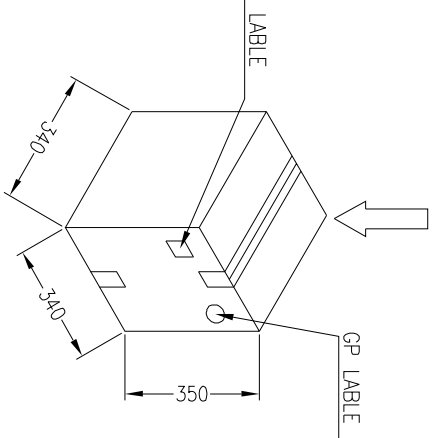
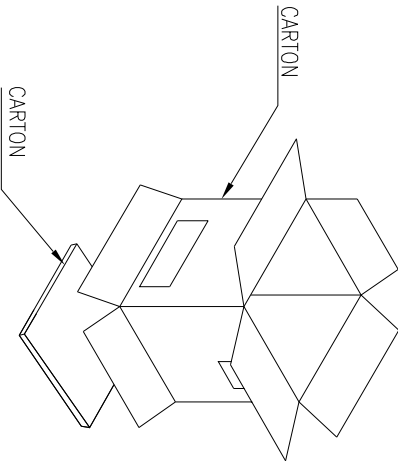
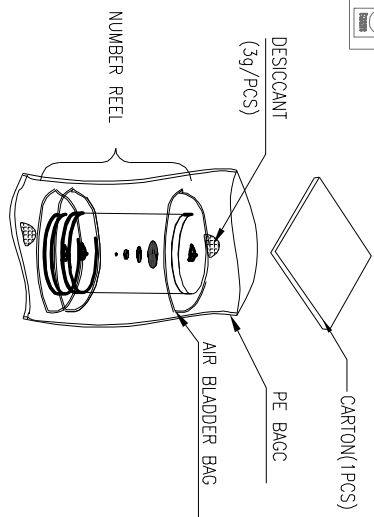

数量16PCS

NOTES:

1. Component load per 13" reel: 1000 pcs
2. Material: white conductive polystyrene alloy.
3. Thickness: 0.4±0.05mm
4. All dimensions meet EIA-481-C requirements

No. of	DIM			REEL (CARTON)	SUM(PCS)
Contacts	A	B	C	5	5000
THD-LVDS-51R-GF	56	26.25	52.5	5	5000

<p>CUSTOMER</p> <p>深圳市臺華達科技有限公司 SHENZHENSHI THD ELECTRONICS CO., LTD.</p>		<p>GENERAL TOLERANCE UNLESS OTHERWISE SPECIFIED</p> <p>OTHERWISE SPECIFIED</p> <p>2012.04.30</p> <p>2012.04.30</p> <p>2012.04.30</p>	
<p>DRAWN: Kavin</p> <p>CHECKED: 胡文</p> <p>APPROVED: 黃繼進</p>		<p>PART NO. THD-LVDS-51R-GF</p> <p>TITLE: 0.5PITCH 3.75H LVDS CONTACT R/A SMT CONN.</p> <p>CONTACT R/A SMT CONN.</p>	
REV.	REVISIONS	CHK	DATE

A B C D E F G H I J

2 3 4 5 6 7 8 9 0

A B C D E F G H I J