

## 32K x 8 Power-Switched and Reprogrammable PROM

### Features

- 5V  $\pm$ 10% VCC, commercial, industrial and military
- Windowed Packages available for re-programmability
- OTP (One-Time-Programmable) Packages available
- High speed
  - 25 ns (commercial)
  - 35 ns (military)
- CMOS for optimum speed/power
- Slim 300-mil package available
- Direct replacement for Cypress PROMs
- Direct replacement for bipolar PROMs
- EPROM technology 100% programmable
- Low power
  - 715 mW (military)
  - 660 mW (commercial)
- Super Low standby power
  - 165 mW when deselected
- TTL-compatible I/O

### General Description

The QP7C271 is a high-performance 32,768-word by 8-bit CMOS PROM. When disabled ( $CE_{BAR}$  HIGH), the QP7C271 automatically powers down into a low-power stand-by mode. The QP7C271 is packaged in the 300-mil slim package. The QP7C271 is available in a hermetic package equipped with an erasure window to provide for re-programmability. When exposed to UV light, the PROM is erased and can be reprogrammed. The memory cells utilize proven EPROM floating gate technology and byte-wide intelligent programming algorithms.

The QP7C271 offers the advantage of lower power, superior performance, and programming yield. The EPROM cell requires only 12.5V for the super voltage, and low current requirements allow for gang programming. The EPROM cells allow each memory location to be tested 100% because each location is written into, erased, and repeatedly exercised prior to encapsulation. Each PROM is also tested for AC performance to guarantee that after customer programming, the product will meet DC and AC specification limits.

Reading the QP7C271 is accomplished by placing active LOW signals on  $CS_{1BAR}$  and  $CE_{BAR}$ , and an active HIGH on  $CS_2$ . The contents of the memory location addressed by the address lines (A0 – A14) will become available on the output lines (O0 – O7).

The device is available in windowed hermetic package (Erasable when exposed to UV light) and is also available in non-windowed OTP (One-Time-Programmable) hermetic or plastic packages.

---

*QP Semiconductor products are not authorized for use in any space applications. The inclusion of QP Semiconductor products in space applications implies that the space application manufacturer assumes all risk of such use and in doing so indemnifies QP Semiconductor against all charges.*

---

# Connection Diagrams

	CerDIP/PDIP/Cerpack 28 Lead	LLCC/LCC/PLCC
<p><b>QP7C271</b></p> <p>Hermetic Packages available in both Erasable (Windowed) and OTP – One-Time-Programmable (Non-Windowed) versions.</p> <p>Molded Plastic Packages (PDIP/PLCC) are only available as OTP (Non-Windowed).</p>		

# Block Diagram

QP7C271

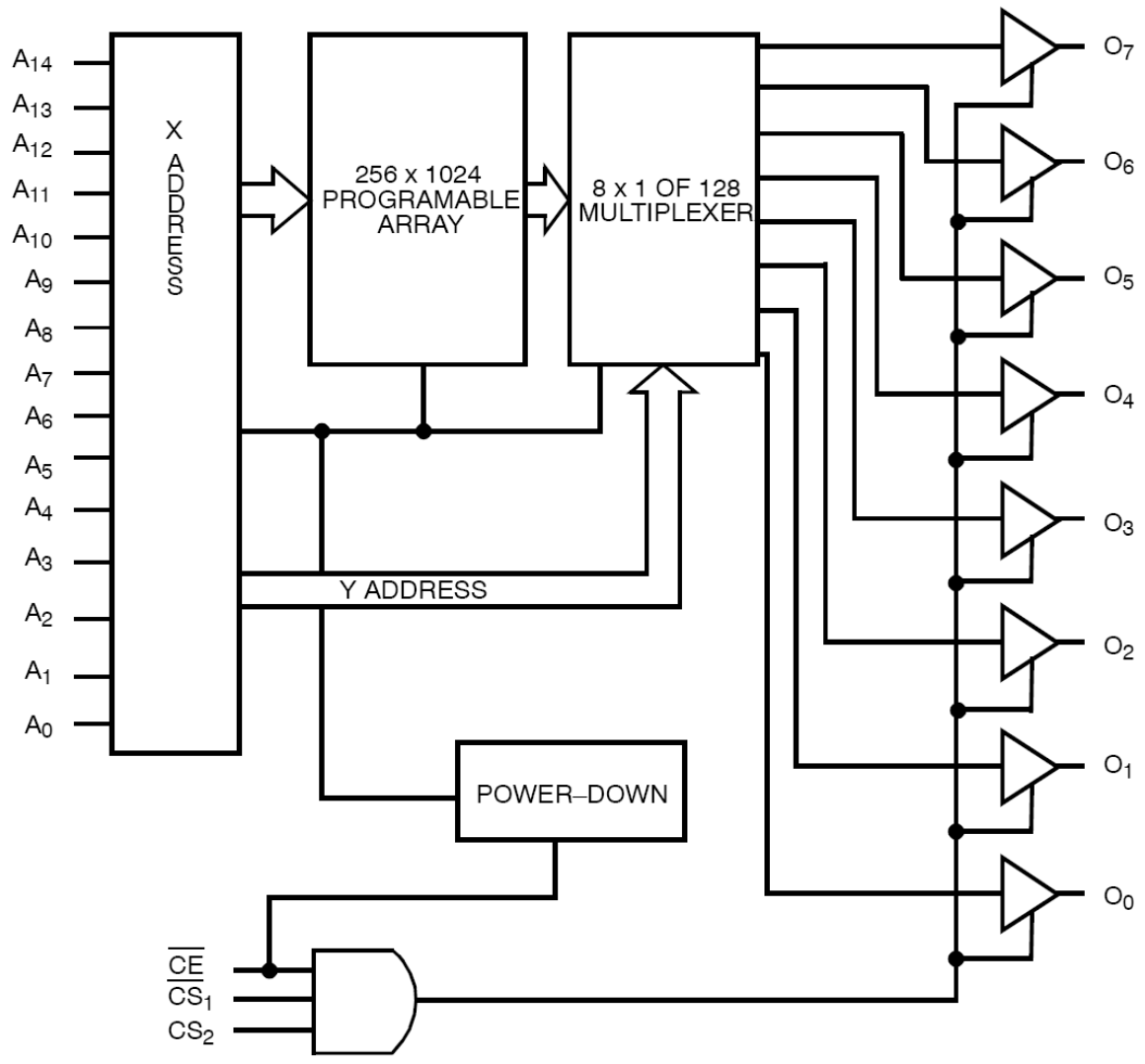

## Absolute Maximum Ratings

Stresses above the AMR may cause permanent damage, extended operation at AMR may degrade performance and affect reliability

Condition	Units	Notes
Supply Voltage to Ground	-0.5 to 7.0 Volts	/1
DC Voltage Applied to Outputs in High Z State	-0.5 to 7.0 Volts	/1
DC Input Voltage	-3.0V to 7.0 Volts	/1
DC Program Voltage	13.0 Volts	
UV Exposure	7258 W <sub>SEC</sub> /cm <sup>2</sup>	
Storage Temperature	-65 to +155 °C	
Ambient Temperature with Power Applied	-55 to +125 °C	/2
Junction Temperature	150 °C	/3 /4

## Recommended Operating Conditions

Condition		Units	Notes
Supply Voltage Range	4.5 to 5.5	Volts DC	5V ± 10%
Case Operating Range (T <sub>c</sub> )	-0C to +70	°C	Commercial
Case Operating Range (T <sub>c</sub> ) /2	-40C to +85	°C	Industrial
Case Operating Range (T <sub>c</sub> ) /2	-55 to +125	°C	Military

### Notes:

Apply to Absolute Maximum, Recommended Operating Conditions and Electrical Performance Characteristics.

/1 – The Voltage on any input or I/O pin cannot exceed the power pin during power-up.

/2 – T<sub>A</sub> is the “instant on” case temperature.

/3– Applies to all versions, but is critical for molded plastic products. T<sub>j</sub> above listed limits can activate mold compound flame retardant.

/4 – Maximum T<sub>J</sub> is not to be exceeded.

/5 – V<sub>CC</sub> 4.5 to 5.5 Volts

/6 – For Test Purposes, not more than one output at a time should be shorted. Short circuit test duration should not exceed 30 seconds.

### TABLE I – ELECTRICAL PERFORMANCE CHARACTERISTICS

Test	Symbol	Conditions /5 Case Operating Range (°C)	Min	Max	Unit
Output Voltage High	V <sub>OH</sub>	V <sub>CC</sub> = 4.5V, I <sub>OH</sub> = -2.0mA	2.4		V
Output Voltage Low	V <sub>OL</sub>	Commercial		0.4	V
		Military/Industrial		0.4	V
Input High Voltage	V <sub>IH</sub>	Guaranteed Input logical High for all inputs	2.0	V <sub>CC</sub>	V
Input Low Voltage	V <sub>IL</sub>	Guaranteed Input logical Low for all inputs		0.8	V
Input Load Current	I <sub>IX</sub>	GND ≤ V <sub>OUT</sub> ≤ V <sub>CC</sub>	-10	10	µA
Output Leakage Current	I <sub>OZ</sub>	GND ≤ V <sub>IN</sub> ≤ V <sub>CC</sub> Output Disabled	-40	40	µA
Output Short Circuit Current /6	I <sub>OS</sub>	V <sub>CC</sub> = 5.5V, V <sub>OUT</sub> = GND	-20	-90	mA
Operating Supply Current	I <sub>CC</sub>	V <sub>CC</sub> = 5.5V, I <sub>OUT</sub> = 0 mA, V <sub>in</sub> = 2.0V, C <sub>E<sub>BAR</sub></sub> = V <sub>IL</sub>			
		Commercial		120	mA
		Military/Industrial		130	mA
Standby Supply Current	I <sub>SB</sub>	V <sub>CC</sub> = 5.5V, I <sub>OUT</sub> = 0 mA, C <sub>E<sub>BAR</sub></sub> = V <sub>IH</sub>			
		Commercial		30	mA
		Military/Industrial		40	mA
Programming Supply Voltage	V <sub>PP</sub>		12	13	V
Programming Supply Current	I <sub>PP</sub>			50	mA

**TABLE I – ELECTRICAL PERFORMANCE CHARACTERISTICS**

Test	Symbol	Conditions /5 Case Operating Range (°C)	Min	Max	Unit
Input High Programming Voltage	$V_{IHP}$		3.0		V
Input Low Programming Voltage	$V_{ILP}$			0.4	V
Input Capacitance	$C_{IN}$	$T_A=25^{\circ}\text{C}$ , $f=1\text{MHz}$ , $V_{CC}=5.0\text{V}$		10	pF
Output Capacitance	$C_{OUT}$	$T_A=25^{\circ}\text{C}$ , $f=1\text{MHz}$ , $V_{CC}=5.0\text{V}$		10	pF
Address to Output Valid	$t_{AA}$	QP7C271 -25		25	nS
		QP7C271 -30		30	nS
		QP7C271 -35		35	nS
		QP7C271 -45		45	nS
		QP7C271 -55		55	nS
Chip Select Inactive to High Z	$t_{HZCS}$	QP7C271 -25		12	nS
		QP7C271 -30		20	nS
		QP7C271 -35		25	nS
		QP7C271 -45		30	nS
		QP7C271 -55		30	nS
Chip Select Active to Output	$t_{ACS}$	QP7C271 -25		12	nS
		QP7C271 -30		20	nS
		QP7C271 -35		25	nS
		QP7C271 -45		30	nS
		QP7C271 -55		30	nS
Chip Enable Inactive to High Z ( $CE_{BAR}$ Only)	$t_{HZCE}$	QP7C271 -25		12	nS
		QP7C271 -30		35	nS
		QP7C271 -35		40	nS
		QP7C271 -45		50	nS
		QP7C271 -55		60	nS
Chip Enable Active to Output Valid ( $CE_{BAR}$ Only)	$t_{ACE}$	QP7C271 -25		30	nS
		QP7C271 -30		35	nS
		QP7C271 -35		40	nS
		QP7C271 -45		50	nS
		QP7C271 -55		60	nS
Chip Enable Active to Power Up	$t_{PU}$		0		nS

**TABLE I – ELECTRICAL PERFORMANCE CHARACTERISTICS**

Test	Symbol	Conditions /5 Case Operating Range (°C)	Min	Max	Unit
Chip Enable Active to Power Down	$t_{PU}$	QP7C271 -25		30	nS
		QP7C271 -30		35	nS
		QP7C271 -35		40	nS
		QP7C271 -45		50	nS
		QP7C271 -55		60	nS
Output Hold from Address Change	$t_{OH}$		0		nS

**AC Test Loads**

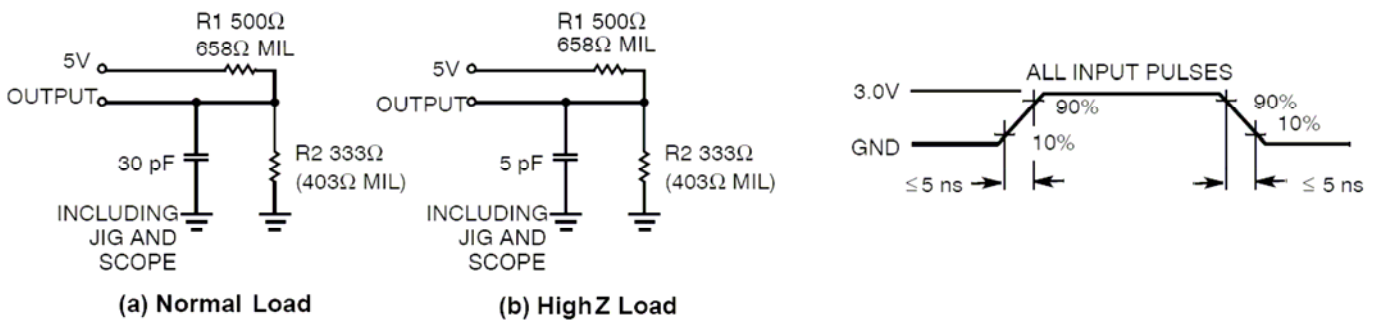

Equivalent to: THÉVENIN EQUIVALENT

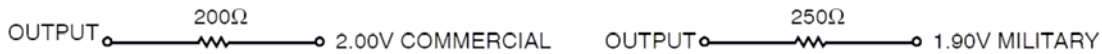

**Waveforms**

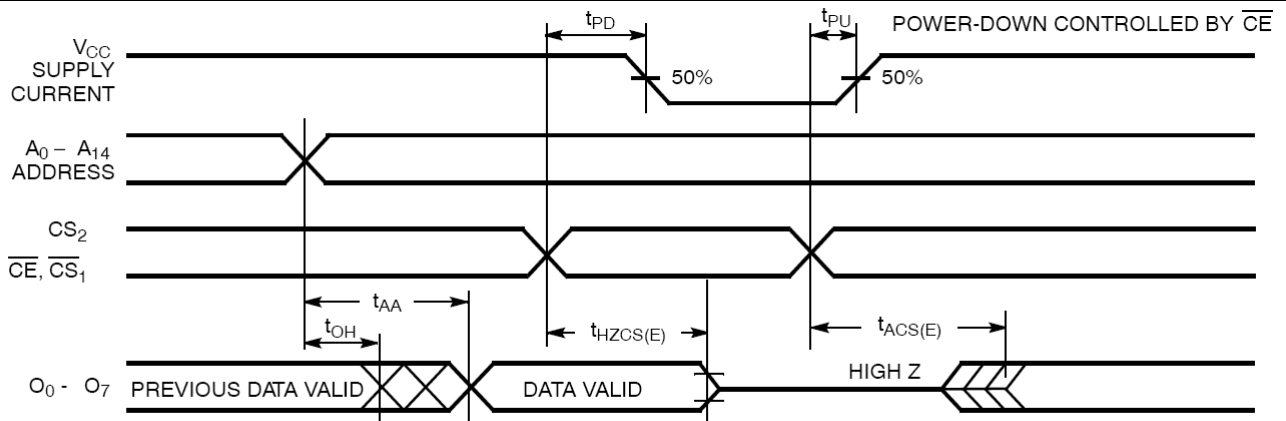

$CS_2$  and  $\overline{CS}_1$  are used on the QP7C271.

Mode Selection Read or Output Disable Program	Pin Function /7 /8				
	$A_{14}-A_0$	$CE_{BAR}$ VFY	$CS_2$ PGM	$CS_{1BAR}$ $V_{PP}$	$O_7-O_0$ $D_7-D_0$
Read	$A_{14}-A_0$	$V_{IL}$	$V_{IH}$	$V_{IL}$	$O_7-O_0$
Power Down	$A_{14}-A_0$	$V_{IH}$	X	X	High Z
Output Disable	$A_{14}-A_0$	X	$V_{IL}$	X	High Z
Output Disable	$A_{14}-A_0$	X	X	$V_{IH}$	High Z
Program	$A_{14}-A_0$	$V_{IHP}$	$V_{ILP}$	$V_{PP}$	$D_7-D_0$
Program Verify	$A_{14}-A_0$	$V_{ILP}$	$V_{IHP} / V_{ILP}$	$V_{PP}$	$O_7-O_0$
Program Inhibit	$A_{14}-A_0$	$V_{IHP}$	$V_{IHP}$	$V_{PP}$	High Z
Blank Check	$A_{14}-A_0$	$V_{ILP}$	$V_{IHP} / V_{ILP}$	$V_{PP}$	$O_7-O_0$

/7 – X = "Don't Care", but not to exceed VCC +5%

/8 –  $V_{PP}$  should be tied to VCC  $\pm 5\%$  in read mode.

### Erase Characteristics:

Wavelengths of light less than 4000 Angstroms begin to erase these PROMs. For this reason, an opaque label should be placed over the window if the PROM is exposed to sunlight or fluorescent lighting for extended periods of time.

The recommended dose of ultraviolet light for erasure is a wavelength of 2537 Angstroms for a minimum dose (UV intensity x exposure time of 25 Wsec/cm<sup>2</sup>. For an ultraviolet lamp with a 12 mW/cm<sup>2</sup> power rating, the exposure time would be approximately 35 minutes. These PROMs need to be within 1 inch of the lamp during erasure. Permanent damage may result if the PROM is exposed to high-intensity UV light for an extended period of time.

7258 Wsec/cm<sup>2</sup> is the recommended maximum dosage.

### Programming Information:

The QP7C271 programs using the same programming algorithm as Cypress 7C271. A variety of programming equipment currently supports the Cypress Algorithm. QP Semiconductor has verified that the devices program on Data I/O Unisite and on a programmer supplied by EETools.

### Ordering Information

Temp Range	$t_{AA}$ ns	Part Number	Package	Mil-Std-1835	Generic
Commercial	25	QP7C271-25JC	32-Lead PLCC	-	Commercial
Commercial	25	QP7C271-25PC	28-Lead 300-mil Plastic DIP	-	Commercial
Commercial	25	QP7C271-25WC	28-Lead 300-mil Windowed CerDIP	GDIP4-T28	Commercial
Commercial	30	QP7C271-30JC	32-Lead PLCC	-	Commercial
Commercial	30	QP7C271-30PC	28-Lead 300-mil Plastic DIP	-	Commercial
Commercial	30	QP7C271-30WC	28-Lead 300-mil Windowed CerDIP	GDIP4-T28	Commercial
Commercial	35	QP7C271-35JC	32-Lead PLCC	-	Commercial
Commercial	35	QP7C271-35PC	28-Lead 300-mil Plastic DIP	-	Commercial
Commercial	35	QP7C271-35WC	28-Lead 300-mil Windowed CerDIP	GDIP4-T28	Commercial
Commercial	45	QP7C271-45JC	32-Lead PLCC	-	Commercial
Commercial	45	QP7C271-45PC	28-Lead 300-mil Plastic DIP	-	Commercial
Commercial	45	QP7C271-45WC	28-Lead 300-mil Windowed CerDIP	GDIP4-T28	Commercial
Commercial	55	QP7C271-55JC	32-Lead PLCC	-	Commercial
Commercial	55	QP7C271-55PC	28-Lead 300-mil Plastic DIP	-	Commercial
Commercial	55	QP7C271-55WC	28-Lead 300-mil Windowed CerDIP	GDIP4-T28	Commercial
Industrial	25	QP7C271-25JI	32-Lead PLCC	-	Industrial
Industrial	25	QP7C271-25PI	28-Lead 300-mil Plastic DIP	-	Industrial
Industrial	25	QP7C271-25WI	28-Lead 300-mil Windowed CerDIP	GDIP4-T28	Industrial

Temp Range	t <sub>AA</sub> ns	Part Number	Package	Mil-Std-1835	Generic
Industrial	30	QP7C271-30JI	32-Lead PLCC	-	Industrial
Industrial	30	QP7C271-30PI	28-Lead 300-mil Plastic DIP	-	Industrial
Industrial	30	QP7C271-30WI	28-Lead 300-mil Windowed CerDIP	GDIP4-T28	Industrial
Industrial	35	QP7C271-35JI	32-Lead PLCC	-	Industrial
Industrial	35	QP7C271-35PI	28-Lead 300-mil Plastic DIP	-	Industrial
Industrial	35	QP7C271-35WI	28-Lead 300-mil Windowed CerDIP	GDIP4-T28	Industrial
Industrial	45	QP7C271-45JI	32-Lead PLCC	-	Industrial
Industrial	45	QP7C271-45PI	28-Lead 300-mil Plastic DIP	-	Industrial
Industrial	45	QP7C271-45WI	28-Lead 300-mil Windowed CerDIP	GDIP4-T28	Industrial
Industrial	55	QP7C271-55JI	32-Lead PLCC	-	Industrial
Industrial	55	QP7C271-55PI	28-Lead 300-mil Plastic DIP	-	Industrial
Industrial	55	QP7C271-55WI	28-Lead 300-mil Windowed CerDIP	GDIP4-T28	Industrial
Military	35	5962-8981703XA	28-Lead 300-mil Windowed CerDIP	GDIP4-T28	Military
Military	35	5962-8981703YA	28-Lead Windowed Flatpack	GDIP2-F28	Military
Military	35	5962-8981703ZA	32-Lead Windowed LCC	CQCC1-N32	Military
Military	35	5962-9316603MXA	28-Lead 300-mil CerDIP	GDIP4-T28	Military
Military	35	5962-9316603MYA	28-Lead Flatpack	GDIP2-F28	Military
Military	35	5962-9316603MZA	32-Lead LCC	CQCC1-N32	Military
Military	35	QP7C271-35DMB	28-Lead 300-mil CerDIP	GDIP4-T28	Military
Military	35	QP7C271-35KMB	28-Lead Flatpack	GDIP2-F28	Military
Military	35	QP7C271-35LMB	32-Lead LCC	CQCC1-N32	Military
Military	35	QP7C271-35QMB	32-Lead Windowed LCC	CQCC1-N32	Military
Military	35	QP7C271-35TMB	28-Lead Windowed Flatpack	GDIP2-F28	Military
Military	35	QP7C271-35WMB	28-Lead 300-mil Windowed CerDIP	GDIP4-T28	Military
Military	45	5962-8981702XA	28-Lead 300-mil Windowed CerDIP	GDIP4-T28	Military
Military	45	5962-8981702YA	28-Lead Windowed Flatpack	GDIP2-F28	Military
Military	45	5962-8981702ZA	32-Lead Windowed LCC	CQCC1-N32	Military
Military	45	5962-9316602MXA	28-Lead 300-mil CerDIP	GDIP4-T28	Military
Military	45	5962-9316602MYA	28-Lead Flatpack	GDIP2-F28	Military
Military	45	5962-9316602MZA	32-Lead LCC	CQCC1-N32	Military
Military	45	QP7C271-45DMB	28-Lead 300-mil CerDIP	GDIP4-T28	Military
Military	45	QP7C271-45KMB	28-Lead Flatpack	GDIP2-F28	Military
Military	45	QP7C271-45LMB	32-Lead LCC	CQCC1-N32	Military
Military	45	QP7C271-45QMB	32-Lead Windowed LCC	CQCC1-N32	Military
Military	45	QP7C271-45TMB	28-Lead Windowed Flatpack	GDIP2-F28	Military
Military	45	QP7C271-45WMB	28-Lead 300-mil Windowed CerDIP	GDIP4-T28	Military
Military	55	5962-8981701XA	28-Lead 300-mil Windowed CerDIP	GDIP4-T28	Military
Military	55	5962-8981701YA	28-Lead Windowed Flatpack	GDIP2-F28	Military
Military	55	5962-8981701ZA	32-Lead Windowed LCC	CQCC1-N32	Military
Military	55	5962-9316601MXA	28-Lead 300-mil CerDIP	GDIP4-T28	Military
Military	55	5962-9316601MYA	28-Lead Flatpack	GDIP2-F28	Military
Military	55	5962-9316601MZA	32-Lead LCC	CQCC1-N32	Military
Military	55	QP7C271-55DMB	28-Lead 300-mil CerDIP	GDIP4-T28	Military
Military	55	QP7C271-55KMB	28-Lead Flatpack	GDIP2-F28	Military
Military	55	QP7C271-55LMB	32-Lead LCC	CQCC1-N32	Military
Military	55	QP7C271-55QMB	32-Lead Windowed LCC	CQCC1-N32	Military
Military	55	QP7C271-55TMB	28-Lead Windowed Flatpack	GDIP2-F28	Military
Military	55	QP7C271-55WMB	28-Lead 300-mil Windowed CerDIP	GDIP4-T28	Military

\* denotes Lead Free Lead Finish

In addition to those products listed above, QP Semiconductor supports Industrial Temperature Range, Source Control Drawing (SCD), and custom package development for this product family.



**Notes:**

Package outline information and specifications are defined by Mil-Std-1835 package dimension requirements.

Products manufactured by QP Semiconductor are compliant to the assembly, burn-in, test and quality conformance requirements of Test Methods 5004 & 5005 of Mil-Std-883 for Class B or Q devices as appropriate. The appropriate DSCC Detail Specifications define the electrical test requirements for each device.

The listed drawings, Mil-PRF-38535, Mil-Std-883 and Mil-Std-1835 are available online at <http://www.dscclia.mil/>

Additional information is available at our website <http://www.qpsemi.com>