

# Magnetic field sensor for pneumatic cylinders BIM-UNR-AP6X W/M

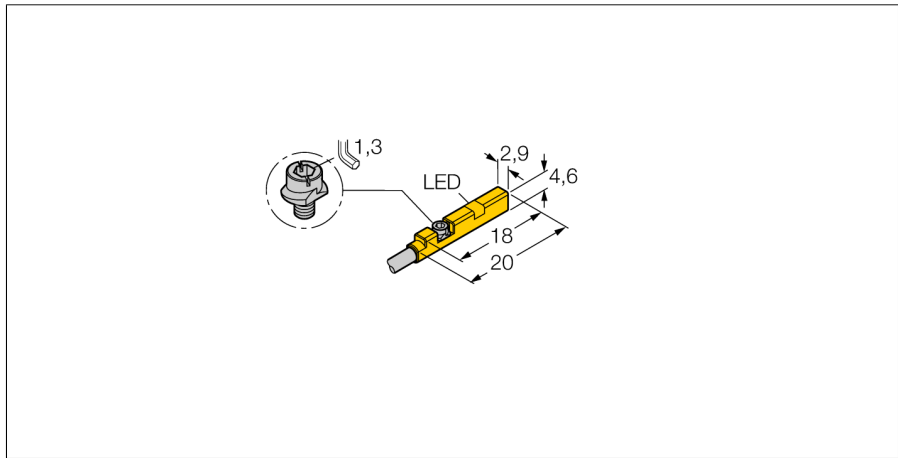

- For C-groove cylinders without mounting accessories
- Optional accessories for mounting on other cylindrical housings.
- One-hand mounting possible
- Stable mounting
- Magneto-resistive sensor
- DC 3-wire, 11...30 VDC
- NO contact, PNP output
- Cable connection

### Wiring Diagram

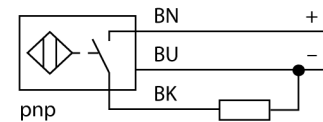

### Functional principle

Magnetic field sensors are activated by magnetic fields and are used, in particular, for the detection of the piston position in pneumatic cylinders. As magnetic fields can permeate non-magnetizable metals, they detect a permanent magnet attached to the piston through the aluminium cylinder wall.

### Derating Curve

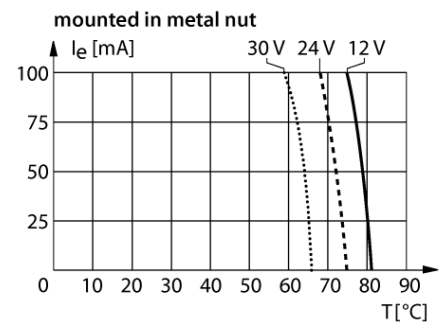
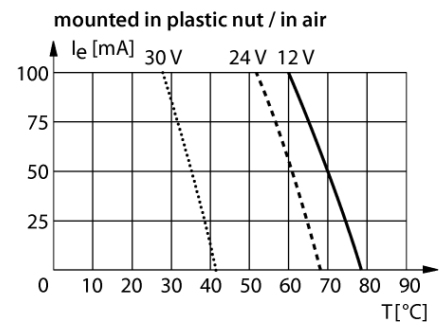

<b>Type designation</b>	BIM-UNR-AP6X W/M
Ident-No.	4685842
Ident-No (TUSA)	S4685842
<b>Pass speed</b>	≤ 3 m/s
Repeatability	≥ ± 0.3 mm
Temperature drift	≤ 0.3 mm
Hysteresis	≤ 1 mm
Ambient temperature	-25...+70 °C
<b>Operating voltage</b>	11...30 VDC
Residual ripple	≤ 10 % U <sub>s</sub>
DC rated operational current	≤ 100 mA
No-load current I <sub>0</sub>	≤ 15 mA
Residual current	≤ 0.1 mA
Isolation test voltage	≤ 0.5 kV
Short-circuit protection	yes/ Cyclic
Voltage drop at I <sub>0</sub>	≤ 1.8 V
Wire breakage/Reverse polarity protection	yes/ Complete
Output function	3-wire, NO contact, PNP
Switching frequency	0.3 kHz
<b>Design</b>	Rectangular, UNR
Dimensions	18 x 2.9 x 4.6 mm
Housing material	Plastic, PP
Active area material	Plastic, PP
Tightening torque fixing screw	0.2 Nm
Electrical connection	Cable
Cable quality	2mm, Gray, Lif9Y-11Y, PUR, 2
Cable cross section	3 x 0.08 mm <sup>2</sup>
Litz wire	40x0.05mm
Vibration resistance	55 Hz (1 mm)
Shock resistance	30 g (11 ms)
Protection class	IP67
MTTF	2283 years acc. to SN 29500 (Ed. 99) 40 °C
Mounting on the following profiles	.
Cylindrical design	
<b>Switching state</b>	LED yellow
Included in delivery	cable clip

# Magnetic field sensor for pneumatic cylinders BIM-UNR-AP6X W/M

**TURCK**  
*works*

Industrial  
Automation

## Mounting instructions/Description

## Mounting instructions

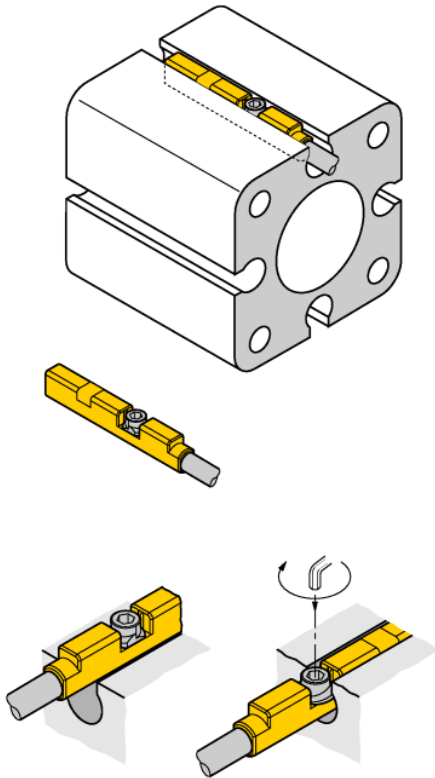

The sensor is mounted in the groove from above. Mount the sensors as follows using the patented wing screw: The wing screw features a left-hand female thread. Two small plastic lips keep the screw in position, ready-to-install. Turn the screw clockwise. The screw moves out of the thread and hits the upper grooves with the wings. The sensor is thus pressed down and locked. Use a 1.5 mm Allen key to fasten the screw with a quarter turn. A fixing torque of 0.2 Nm is sufficient for safe mounting without damaging the cylinder. Cable clips are included in the scope of delivery. They enable smooth cable routing in the groove. Mounting accessories for other cylinder sizes have to be ordered separately.