



Base/bracket mounting



Tube mounting - tube and base for tube (accessories)

- Extremely high light intensity of more than 105 cd
- Intense double flash with low power consumption
- Generates a high signal effect thanks to two consecutive flashes

Life duration up to 50,000 hrs

TECHNICAL SPECIFICATIONS:

Dimensions (Diameter x Height):	100 mm x 138.5 mm (Base/Bracket Mounting) 100 mm x 200 mm (Tube Mounting)
Housing:	PC/ABS-Blend
Dome:	PC, transparent
Fixing:	Base mounting, bracket mounting (accessory), tube mounting (accessory)
Cable entry:	Cable diameter 5-7 mm
Connection:	Screwable conn. with wire protection max. 2.5 mm ² Contact protection according to VDE
Light output:	up to 105 cd (clear)
Voltage:	24 V _{DC} , 115-230 V _{AC}
Current consumption:	< 100 mA

ORDER SPECIFICATIONS:

Base Mounting/Bracket Mounting

Voltage	24 V _{DC}	115-230 V _{AC}
red	829 120 55	829 120 68
yellow	829 320 55	829 320 68
clear	829 420 55	829 420 68

Tube Mounting

Voltage	24 V _{DC}	115-230 V _{AC}
red	829 127 55	829 127 68
yellow	829 327 55	829 327 68
clear	829 427 55	829 427 68

Available: 1st Quarter 2010 (115-230 V version).

ACCESSORIES:

Plastic bracket for wall mounting	975 826 05
Wire guard, galvanised, for base mounting	975 826 03
Tube Ø 25 mm, all anodized aluminium, 100 mm long	975 845 10
Base for tube, plastic	975 840 90
Base for tube, metal	975 840 91

(see page 26)

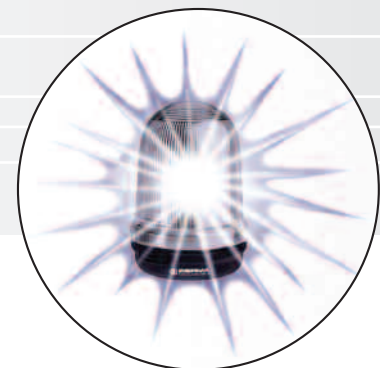

Attention-grabbing LED Double Flash with a life duration of up to 50,000 hours

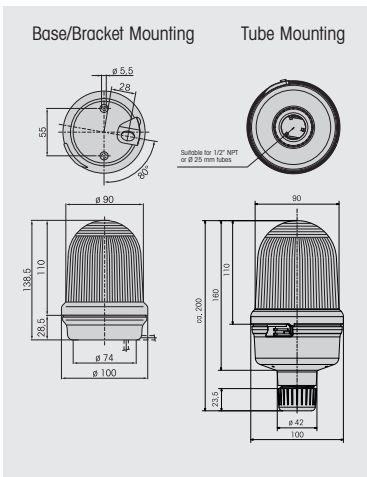

In preparation

Base/Bracket Mounting: 200g, 235g

Tube Mounting: 235g

IP 65

+50°C / -20°C

105