

### Features

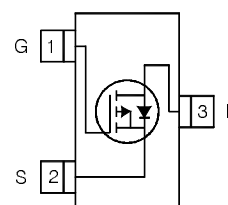
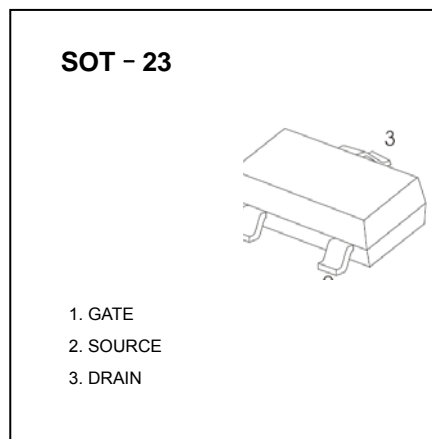
- $V_{DS} (V) = -20V$
- $I_D = 2A$
- $R_{DS(ON)} < 135m\Omega$  ( $V_{GS} = -4.5V$ )
- $R_{DS(ON)} < 236m\Omega$  ( $V_{GS} = -2.5V$ )
- Industry-standard pinout
- Compatible with existing Surface Mount Techniques
- RoHS compliant

### Application(s)

- System/Load Switch

### Benefits

- Multi-vendor compatibility
- Easier manufacturing
- Environmentally friendly
- Increased reliability



### Absolute Maximum Ratings

Symbol	Parameter		Units
$V_{DS}$	Drain-Source Voltage	-20	V
$I_D @ T_A = 25^\circ C$	Continuous Drain Current, $V_{GS} @ -10V$	-2.6	A
$I_D @ T_A = 70^\circ C$	Continuous Drain Current, $V_{GS} @ -10V$	-2.1	
$I_{DM}$	Pulsed Drain Current	-11	
$P_D @ T_A = 25^\circ C$	Maximum Power Dissipation	1.3	W
$P_D @ T_A = 70^\circ C$	Maximum Power Dissipation	0.80	
	Linear Derating Factor	0.01	W/°C
$V_{GS}$	Gate-to-Source Voltage	$\pm 12$	V
$T_J, T_{STG}$	Junction and Storage Temperature Range	-55 to + 150	°C

### Thermal Resistance

Symbol	Parameter	Typ.	Max.	Units
$R_{\theta JA}$	Junction-to-Ambient <sup>③</sup>		100	°C/W
$R_{\theta JA}$	Junction-to-Ambient ( $t < 10s$ ) <sup>④</sup>		99	

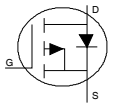
#### Notes:

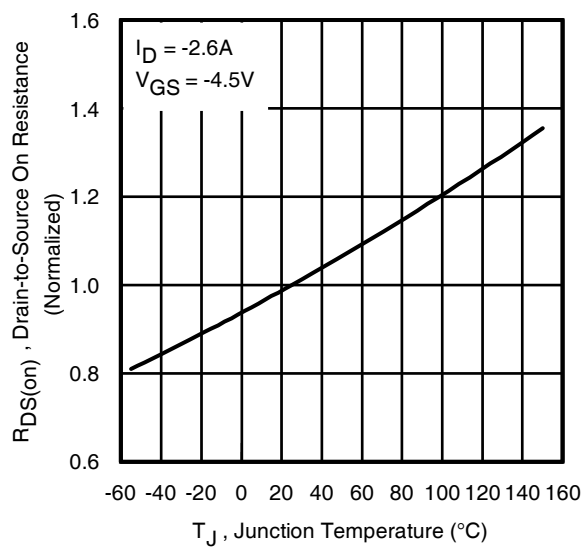
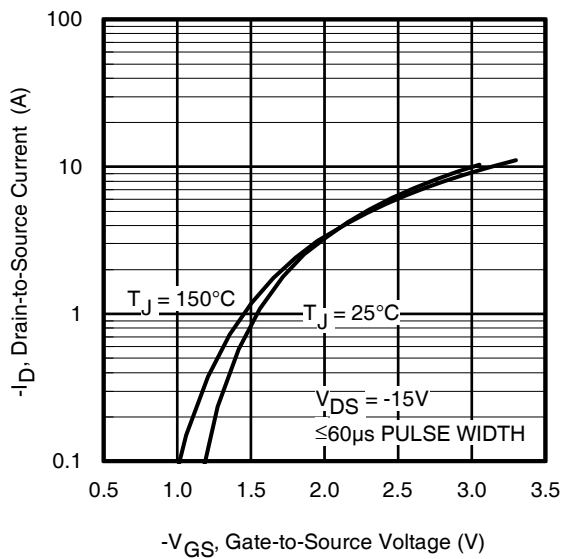
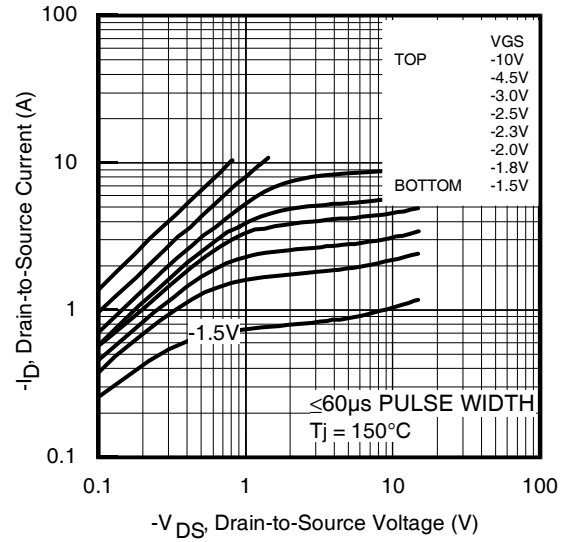
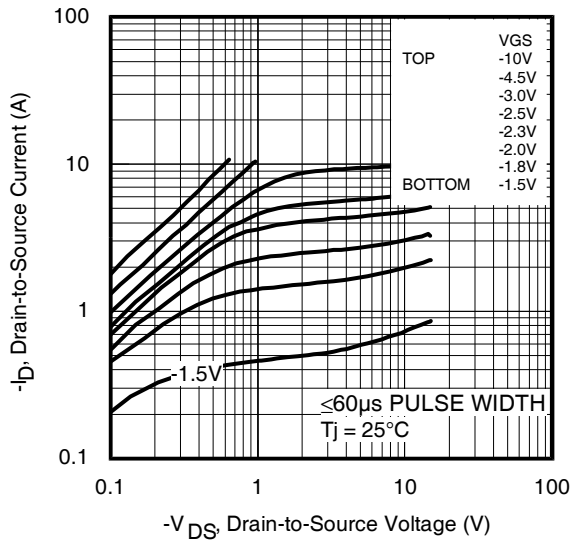
- ① Repetitive rating; pulse width limited by max. junction temperature.
- ② Pulse width  $\leq 400\mu s$ ; duty cycle  $\leq 2\%$ .
- ③ Surface mounted on 1 in square Cu board.

**Electric Characteristics @ T<sub>J</sub> = 25°C (unless otherwise specified)**

Symbol	Parameter	Min.	Typ.	Max.	Units	Conditions
V <sub>(BR)DSS</sub>	Drain-to-Source Breakdown Voltage	-20			V	V <sub>GS</sub> = 0V, I <sub>D</sub> = -250μA
ΔV <sub>(BR)DSS</sub> /ΔT <sub>J</sub>	Breakdown Voltage Temp. Coefficient		9.5		mV/°C	Reference to 25°C, I <sub>D</sub> = -1mA
R <sub>DS(on)</sub>	Static Drain-to-Source On-Resistance		90	135	mΩ	V <sub>GS</sub> = -4.5V, I <sub>D</sub> = -2.6A ②
			157	236		V <sub>GS</sub> = -2.5V, I <sub>D</sub> = -2.1A ②
V <sub>GS(th)</sub>	Gate Threshold Voltage	-0.4		-1.1	V	V <sub>DS</sub> = V <sub>GS</sub> , I <sub>D</sub> = -10μA
I <sub>DSS</sub>	Drain-to-Source Leakage Current			-1.0	μA	V <sub>DS</sub> = -16V, V <sub>GS</sub> = 0V
				-150		V <sub>DS</sub> = -16V, V <sub>GS</sub> = 0V, T <sub>J</sub> = 125°C
I <sub>GSS</sub>	Gate-to-Source Forward Leakage			100	nA	V <sub>GS</sub> = 12V
	Gate-to-Source Reverse Leakage			-100		V <sub>GS</sub> = -12V
R <sub>G</sub>	Internal Gate Resistance		16		Ω	
g <sub>fs</sub>	Forward Transconductance	3.4			S	V <sub>DS</sub> = -10V, I <sub>D</sub> = -2.6A
Q <sub>g</sub>	Total Gate Charge		2.9		nC	I <sub>D</sub> = -2.6A
Q <sub>gs</sub>	Gate-to-Source Charge		0.52			V <sub>DS</sub> = -10V
Q <sub>gd</sub>	Gate-to-Drain ("Miller") Charge		1.2			V <sub>GS</sub> = -4.5V ②
t <sub>d(on)</sub>	Turn-On Delay Time		5.3		ns	V <sub>DD</sub> = -10V ②
t <sub>r</sub>	Rise Time		7.7			I <sub>D</sub> = -1.0A
t <sub>d(off)</sub>	Turn-Off Delay Time		26			R <sub>G</sub> = 6.8Ω
t <sub>f</sub>	Fall Time		16			V <sub>GS</sub> = -4.5V
C <sub>iss</sub>	Input Capacitance		220		pF	V <sub>GS</sub> = 0V
C <sub>oss</sub>	Output Capacitance		70			V <sub>DS</sub> = -16V
C <sub>rss</sub>	Reverse Transfer Capacitance		48			f = 1.0KHz

**Source - Drain Ratings and Characteristics**

Symbol	Parameter	Min.	Typ.	Max.	Units	Conditions
I <sub>S</sub>	Continuous Source Current			-1.3	A	MOSFET symbol showing the integral reverse p-n junction diode. 
I <sub>SM</sub>	Pulsed Source Current (Body Diode) ①			-11		
V <sub>SD</sub>	Diode Forward Voltage			-1.2	V	T <sub>J</sub> = 25°C, I <sub>S</sub> = -2.6A, V <sub>GS</sub> = 0V ②
t <sub>rr</sub>	Reverse Recovery Time		17	26	ns	T <sub>J</sub> = 25°C, V <sub>R</sub> = -15V, I <sub>F</sub> = -2.6A
Q <sub>rr</sub>	Reverse Recovery Charge		6.2	9.3	nC	di/dt = 100A/μs ②



Typical Electrical Characteristics

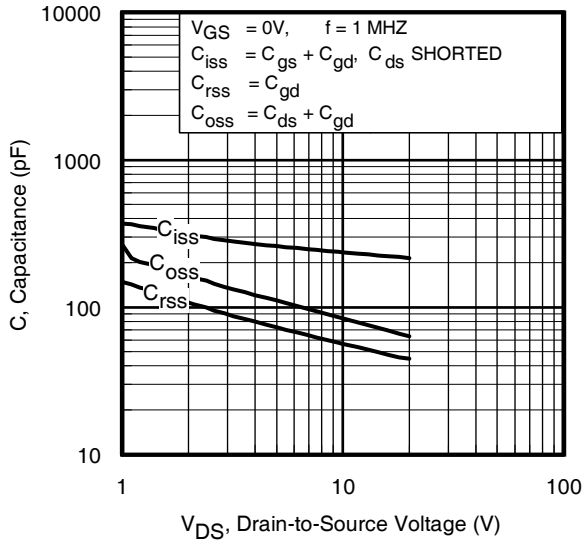


Fig 5. Typical Capacitance vs. Drain-to-Source Voltage

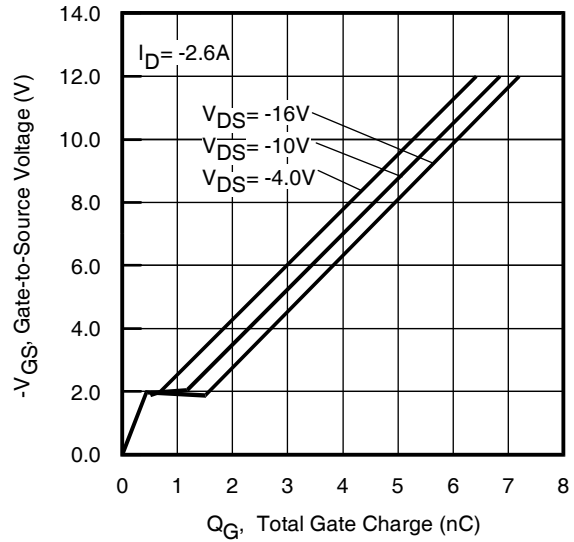


Fig 6. Typical Gate Charge vs. Gate-to-Source Voltage

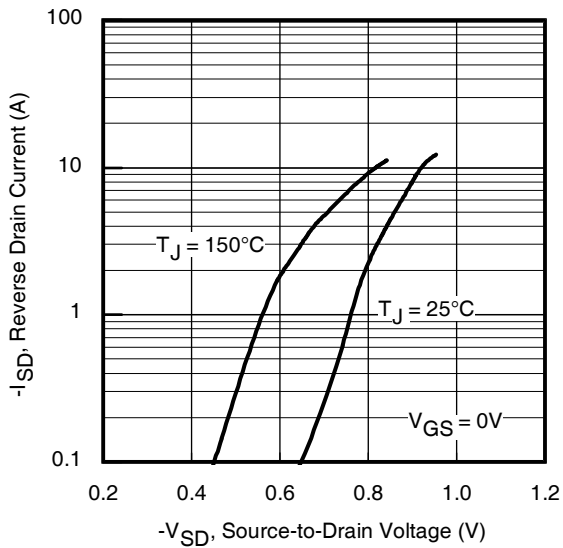


Fig 7. Typical Source-Drain Diode Forward Voltage

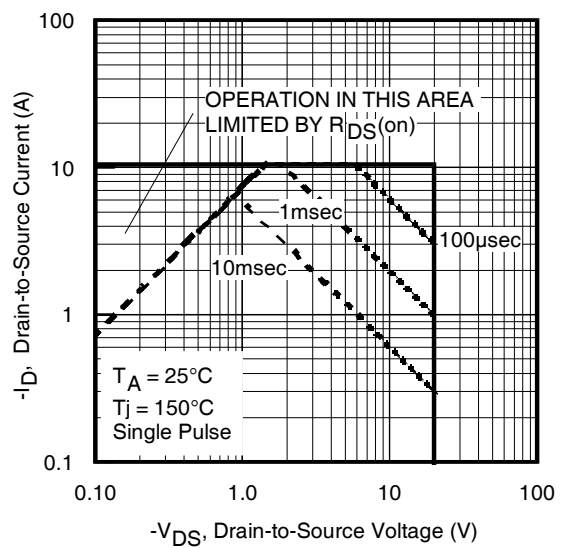
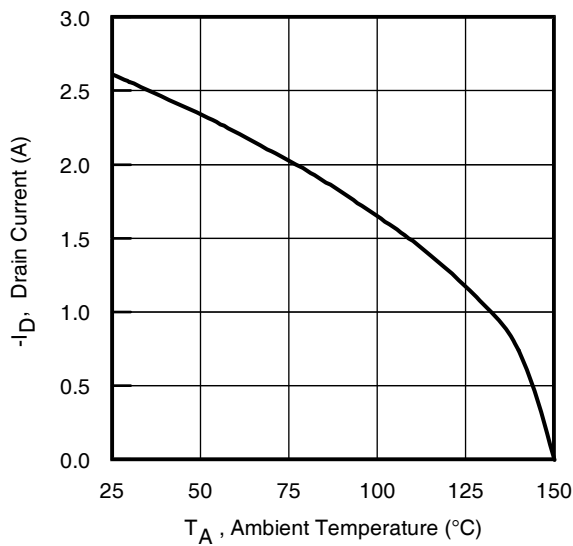
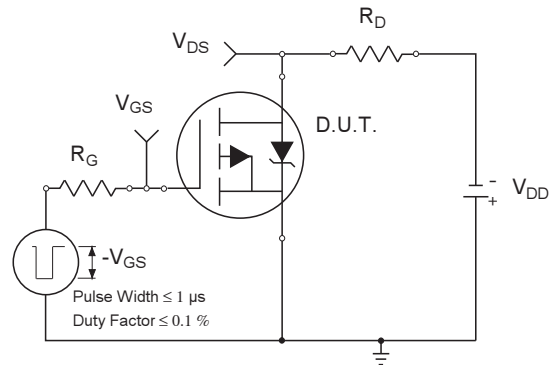


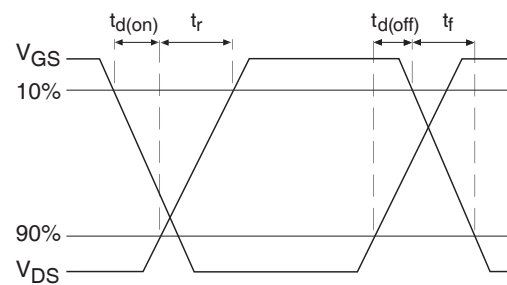
Fig 8. Maximum Safe Operating Area



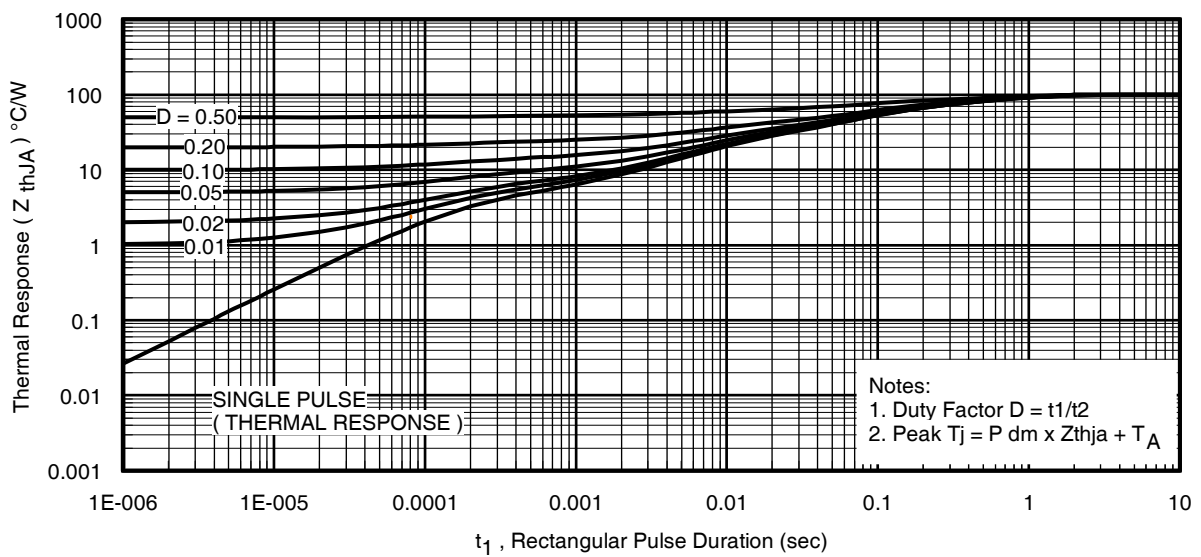
**Fig 9.** Maximum Drain Current vs. Ambient Temperature



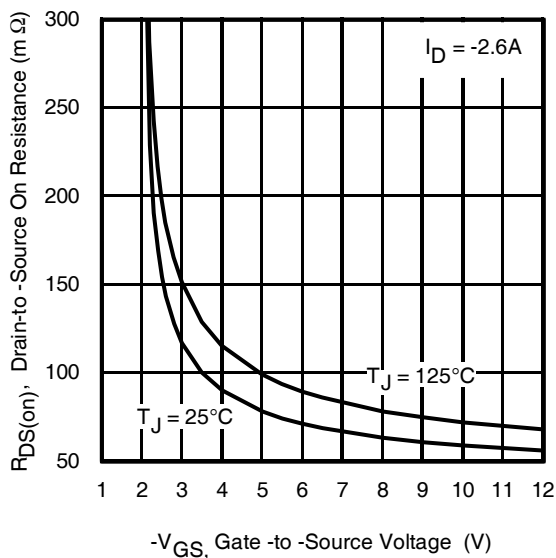
**Fig 10a.** Switching Time Test Circuit



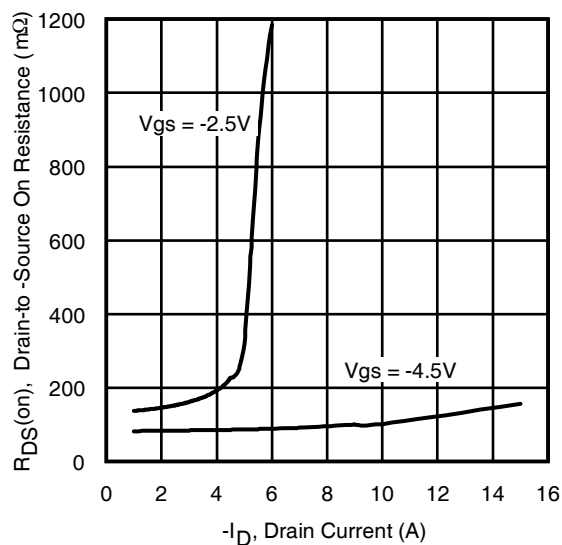
**Fig 10b.** Switching Time Waveforms



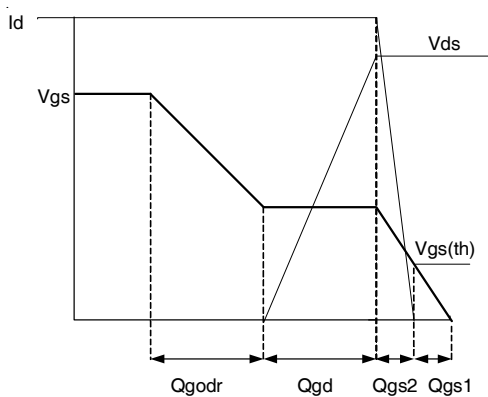
**Fig 11.** Typical Effective Transient Thermal Impedance, Junction-to-Ambient



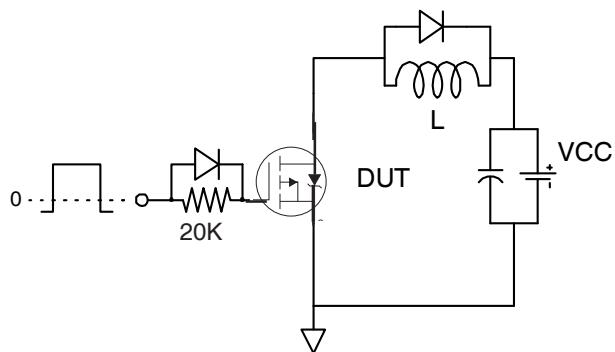
**Fig 12.** Typical On-Resistance vs. Gate Voltage



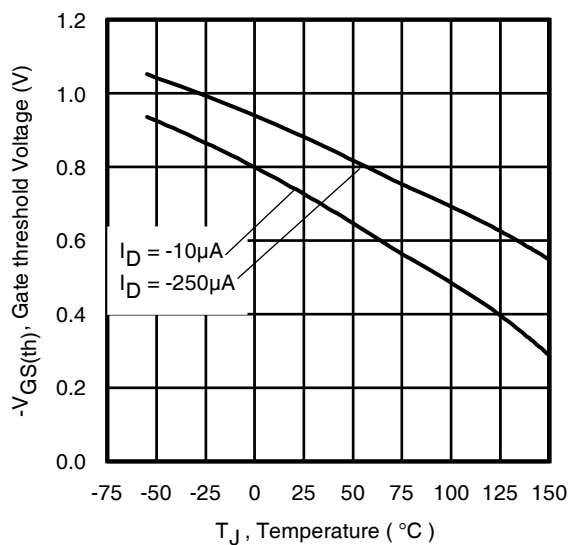
**Fig 13.** Typical On-Resistance vs. Drain Current



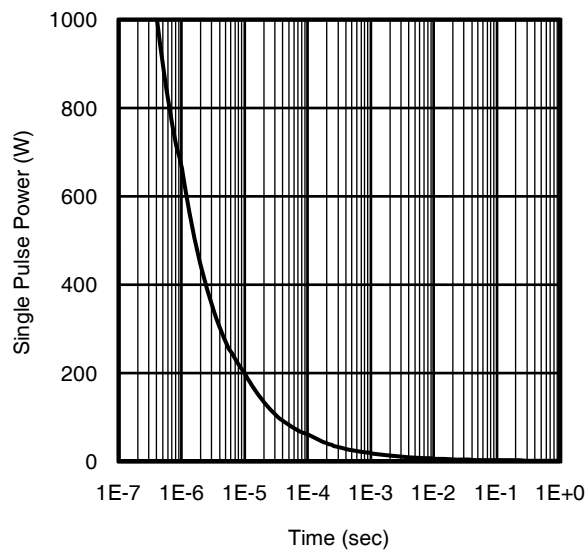
**Fig 14a.** Basic Gate Charge Waveform



**Fig 14b.** Gate Charge Test Circuit

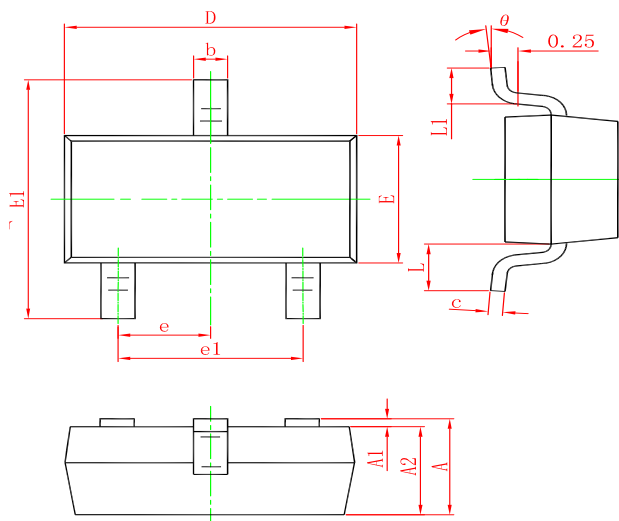


**Fig 15.** Typical Threshold Voltage vs. Junction Temperature



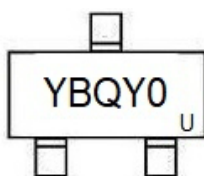
**Fig 16.** Typical Power vs. Time

**SOT-23 PACKAGE OUTLINE DIMENSIONS**



Symbol	Dimensions In Millimeters		Dimensions In Inches	
	Min.	Max.	Min.	Max.
A	0.900	1.150	0.035	0.045
A1	0.000	0.100	0.000	0.004
A2	0.900	1.050	0.035	0.041
b	0.300	0.500	0.012	0.020
c	0.080	0.150	0.003	0.006
D	2.800	3.000	0.110	0.118
E	1.200	1.400	0.047	0.055
E1	2.250	2.550	0.089	0.100
e	0.950 TYP.		0.037 TYP.	
e1	1.800	2.000	0.071	0.079
L	0.550 REF.		0.022 REF.	
L1	0.300	0.500	0.012	0.020
θ	0°	8°	0°	8°

**Marking**



**Ordering information**

Order code	Package	Baseqty	Deliverymode
UMW IRLML2246	SOT-23	3000	Tape and reel