

SMKDS 5/ 2-9,5 - PCB terminal block



1720017

<https://www.phoenixcontact.com/us/products/1720017>

Please be informed that the data shown in this PDF document is generated from our online catalog. Please find the complete data in the user documentation. Our general terms of use for downloads are valid.



PCB terminal block, nominal current: 32 A, rated voltage (III/2): 1000 V, nominal cross section: 4 mm², number of potentials: 2, number of rows: 1, number of positions per row: 2, product range: SMKDS 5, pitch: 9.52 mm, connection method: Screw connection with tension sleeve, screw head form: L Slotted, mounting: Wave soldering, conductor/PCB connection direction: 35 °, color: green, Pin layout: Linear pinning, Solder pin [P]: 5 mm, number of solder pins per potential: 1, type of packaging: packed in cardboard. The article can be aligned to create different nos. of positions!

Your advantages

- Well-known connection principle allows worldwide use
- Low temperature rise, thanks to maximum contact force
- Allows connection of two conductors
- The latching on the side enables various numbers of positions to be combined
- Angled connection enables multi-row arrangement on the PCB

Commercial data

Item number	1720017
Packing unit	50 pc
Minimum order quantity	50 pc
Sales key	AA14
Product key	AANFDN
Catalog page	Page 447 (C-1-2013)
GTIN	4017918024970
Weight per piece (including packing)	6.523 g
Weight per piece (excluding packing)	6.523 g
Customs tariff number	85369010
Country of origin	PL

SMKDS 5/ 2-9,5 - PCB terminal block



1720017

<https://www.phoenixcontact.com/us/products/1720017>

Technical data

Product properties

Product type	Printed circuit board terminal
Product family	SMKDS 5
Product line	COMBICON Terminals L
Type	PC terminal block can be aligned
Number of positions	2
Pitch	9.52 mm
Number of connections	2
Number of rows	1
Number of potentials	2
Pin layout	Linear pinning
Solder pins per potential	1

Electrical properties

Nominal current I_N	32 A
Nominal voltage U_N	1000 V
Degree of pollution	3
Rated voltage (III/3)	690 V
Rated surge voltage (III/3)	6 kV
Rated voltage (III/2)	1000 V
Rated surge voltage (III/2)	6 kV
Rated voltage (II/2)	1000 V
Rated surge voltage (II/2)	6 kV

Connection data

Connection technology

Type	PC terminal block can be aligned
Nominal cross section	4 mm ²

Conductor connection

Connection method	Screw connection with tension sleeve
Conductor cross section rigid	0.2 mm ² ... 6 mm ²
Conductor cross section flexible	0.2 mm ² ... 4 mm ²
Conductor cross section AWG	24 ... 10
Conductor cross section flexible, with ferrule without plastic sleeve	0.25 mm ² ... 4 mm ²
Conductor cross section, flexible, with ferrule, with plastic sleeve	0.25 mm ² ... 4 mm ²
2 conductors with same cross section, solid	0.2 mm ² ... 1.5 mm ²
2 conductors with same cross section, flexible	0.2 mm ² ... 1.5 mm ²
2 conductors with same cross section, flexible, with ferrule without plastic sleeve	0.25 mm ² ... 0.75 mm ²
2 conductors with the same cross section, flexible, with TWIN	0.5 mm ² ... 2.5 mm ²

SMKDS 5/ 2-9,5 - PCB terminal block



1720017

<https://www.phoenixcontact.com/us/products/1720017>

ferrule with plastic sleeve	
Stripping length	8 mm
Tightening torque	0.5 Nm ... 0.6 Nm

Mounting

Mounting type	Wave soldering
Pin layout	Linear pinning
Drive form screw head	Slotted (L)

Material specifications

Material data - contact

Note	WEEE/RoHS-compliant, free of whiskers according to IEC 60068-2-82/JEDEC JESD 201
Contact material	Cu alloy
Surface characteristics	Tin-plated
Metal surface terminal point (top layer)	Tin (5 - 7 μm Sn)
Metal surface soldering area (top layer)	Tin (5 - 7 μm Sn)

Material data - housing

Color (Housing)	green (6021)
Insulating material	PA
Insulating material group	I
CTI according to IEC 60112	600
Flammability rating according to UL 94	V2

Notes

Note on application	For safe conductor connection, always adhere to a defined tightening torque. Particularly in the case of PCB terminal blocks with two or three positions, the individual solder pin for each contact point cannot compensate for this. That is why the terminal blocks must be supported during conductor connection (held with one hand, support on the housing).
---------------------	--

Dimensions

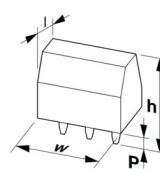
Dimensional drawing	
Pitch	9.52 mm
Width [w]	19.04 mm
Height [h]	26.5 mm
Length [l]	18.5 mm
Installed height	21.5 mm
Solder pin length [P]	5 mm

SMKDS 5/ 2-9,5 - PCB terminal block



1720017

<https://www.phoenixcontact.com/us/products/1720017>

Pin dimensions	0.9 x 0.9 mm
PCB design	
Hole diameter	1.3 mm

Electrical tests

Air clearances and creepage distances |

Specification	IEC 60664-1:2007-04
Insulating material group	I
Comparative tracking index (IEC 60112)	CTI 600
Rated insulation voltage (III/3)	690 V
Rated surge voltage (III/3)	6 kV
minimum clearance value - non-homogenous field (III/3)	5.5 mm
minimum creepage distance (III/3)	8 mm
Rated insulation voltage (III/2)	1000 V
Rated surge voltage (III/2)	6 kV
minimum clearance value - non-homogenous field (III/2)	5.5 mm
minimum creepage distance (III/2)	5.5 mm
Rated insulation voltage (II/2)	1000 V
Rated surge voltage (II/2)	6 kV
minimum clearance value - non-homogenous field (II/2)	5.5 mm

Environmental and real-life conditions

Ambient conditions

Ambient temperature (operation)	-40 °C ... 100 °C (Depending on the current carrying capacity/derating curve)
Ambient temperature (storage/transport)	-40 °C ... 70 °C
Relative humidity (storage/transport)	30 % ... 70 %
Ambient temperature (assembly)	-5 °C ... 100 °C

Packaging specifications

Type of packaging	packed in cardboard
-------------------	---------------------

SMKDS 5/ 2-9,5 - PCB terminal block

1720017

<https://www.phoenixcontact.com/us/products/1720017>

Drawings

Dimensional drawing

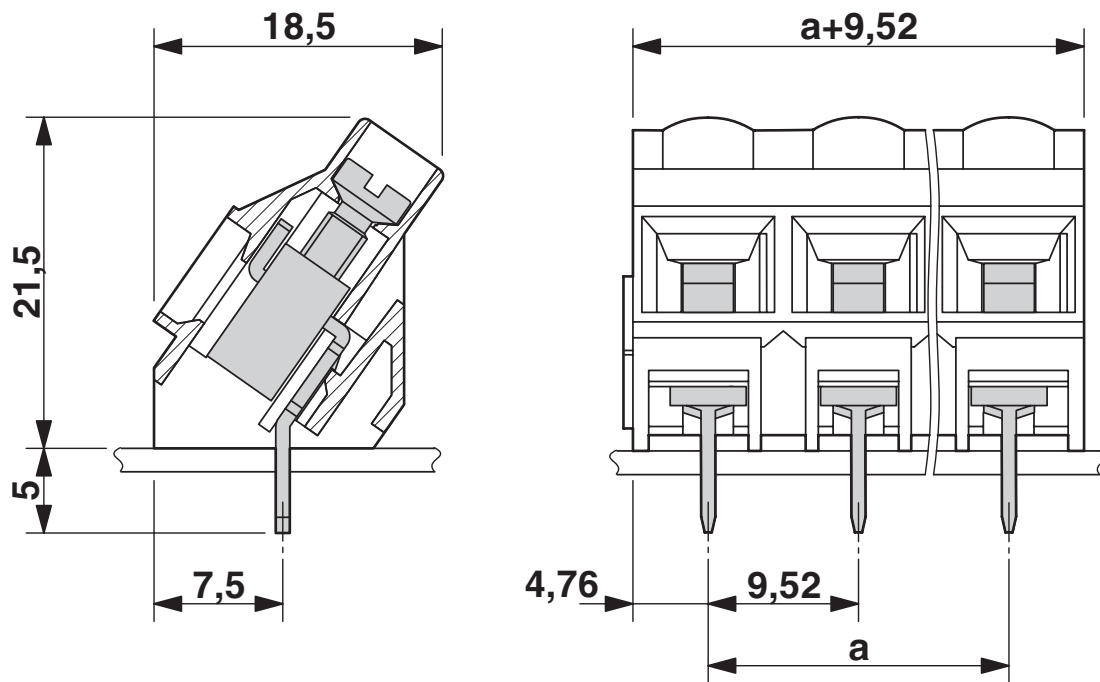

Drilling plan/solder pad geometry

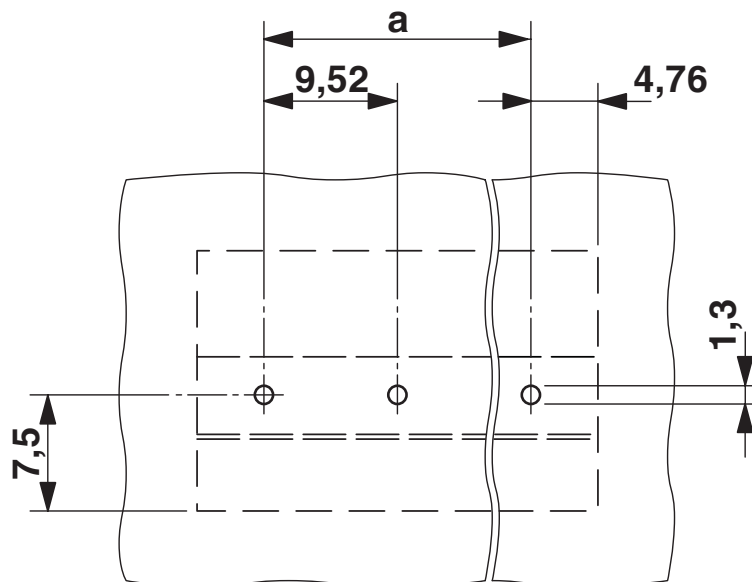

SMKDS 5/ 2-9,5 - PCB terminal block





1720017

<https://www.phoenixcontact.com/us/products/1720017>

Approvals

To download certificates, visit the product detail page: <https://www.phoenixcontact.com/us/products/1720017>

 CSA Approval ID: 13631				
	Nominal voltage U_N	Nominal current I_N	Cross section AWG	Cross section mm^2
Use group B				
	300 V	30 A	28 - 10	-
Use group C				
	300 V	30 A	28 - 10	-

 cULus Recognized Approval ID: E60425-19870331				
	Nominal voltage U_N	Nominal current I_N	Cross section AWG	Cross section mm^2
Use group B				
	250 V	30 A	30 - 10	-
Use group C				
	300 V	30 A	30 - 10	-

 VDE Zeichengenehmigung Approval ID: 40055394				
	Nominal voltage U_N	Nominal current I_N	Cross section AWG	Cross section mm^2
	1000 V	32 A	-	0.2 - 4

SMKDS 5/ 2-9,5 - PCB terminal block



1720017

<https://www.phoenixcontact.com/us/products/1720017>

Classifications

ECLASS

ECLASS-11.0	27460101
ECLASS-12.0	27460101
ECLASS-13.0	27460101

ETIM

ETIM 9.0	EC002643
----------	----------

UNSPSC

UNSPSC 21.0	39121400
-------------	----------

SMKDS 5/ 2-9,5 - PCB terminal block



1720017

<https://www.phoenixcontact.com/us/products/1720017>

Environmental product compliance

EU RoHS

Fulfills EU RoHS substance requirements	Yes, No exemptions
---	--------------------

China RoHS

Environment friendly use period (EFUP)	EFUP-E
	No hazardous substances above the limits

EU REACH SVHC

REACH candidate substance (CAS No.)	No substance above 0.1 wt%
-------------------------------------	----------------------------

SMKDS 5/ 2-9,5 - PCB terminal block



1720017

<https://www.phoenixcontact.com/us/products/1720017>

Accessories

SZS 0,6X3,5 - Screwdriver

1205053

<https://www.phoenixcontact.com/us/products/1205053>



Actuation tool, for ST terminal blocks, insulated, also suitable for use as a bladed screwdriver, size: 0.6 x 3.5 x 100 mm, 2-component grip, with non-slip grip

SK 5,0 WH:REEL - Marker strip

0805221

<https://www.phoenixcontact.com/us/products/0805221>



Marker strip, Roll, white, unlabeled, can be labeled with: THERMOMARK E.300 (D)/600 (D), THERMOMARK ROLL 2.0, THERMOMARK ROLL, THERMOMARK ROLL X1, THERMOMARK ROLLMASTER 300/600, THERMOMARK X1.2, mounting type: adhesive, lettering field size: continuous x 5 mm, Number of individual labels: 10

Phoenix Contact 2024 © - all rights reserved

<https://www.phoenixcontact.com>

Phoenix Contact USA

586 Fulling Mill Road

Middletown, PA 17057, United States

(+717) 944-1300

info@phoenixcon.com