

LED80-04 BEACON

LOW VOLTAGE AND EMC DIRECTIVES

This beacon is CE-marked to show compliance with the Low Voltage Directive 2006/95/EC and the Electromagnetic Compatibility Directive 2004/108/EC. To maintain compliance with these directives it is necessary that installation is carried out in accordance with this instructions - if in doubt a qualified electrician should be consulted.

1. This beacon is designed to comply with IP67 when correctly installed. To ensure a weatherproof installation the beacon must be fitted with the foam gasket and mounted on a flat panel or surface. The panel or surface should be drilled to accept the wires and M4 studs as shown.(various fitting accessories are available-consult factory)

Access to the power supply wires must be prevented either by fitting a suitable sleeve or by means of an insulating barrier.

2. Connect the blue and brown wires to the mains supply (110/230V 50Hz) ensuring that the brown wire is connected to the live terminal.

3. Connecting the white wire to the neutral terminal will cause the beacon to operate in constantly lit mode . Flashing mode is selected by leaving the white wire disconnected.

LED80-04 BEACON

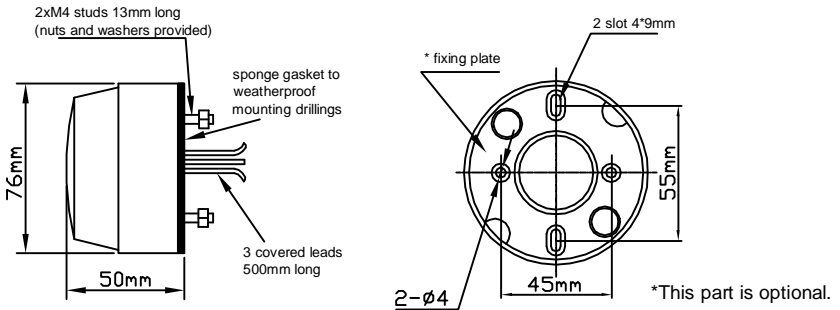

LED80-04 BEACON RANGE INSTALLATION

