

SOCKET TERMINAL  
42024-\*\*\*

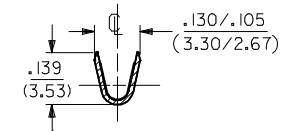

SECTION "B-B"  
WIRE CRIMP AREA

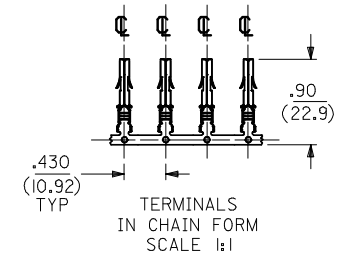
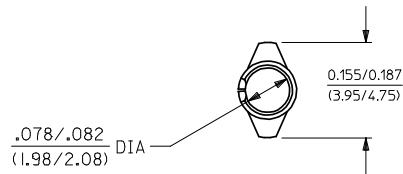
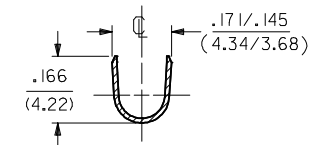

SECTION "A-A"  
INSULATION CRIMP AREA

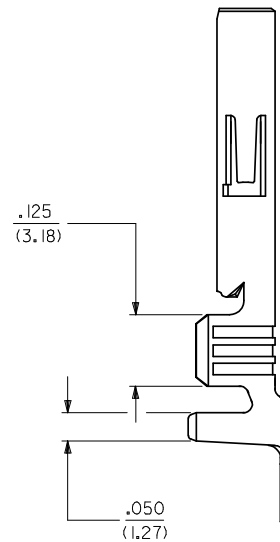
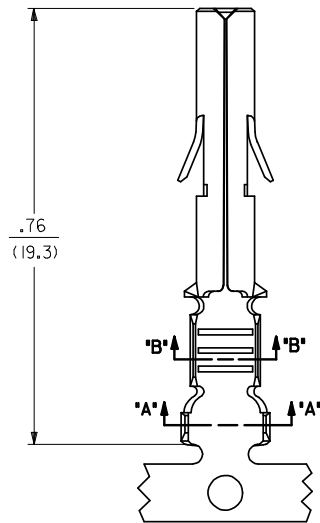

SEE SHEET 2 FOR CHART, MATERIAL, PLATING, NOTES, AND CRIMP OPTIONS

ENTER DESCRIPTION EC NO: 12008-0359 DRAWN BY: 2008/03/03 CHKD: VINU 2008/03/03 APPR: KPRASAD 2008/03/03	QUALITY SYMBOLS ▽=0 ▽=0	GENERAL TOLERANCES (UNLESS SPECIFIED)		DIMENSION STYLE	SCALE	DESIGN UNITS	THIRD ANGLE PROJECTION
		mm	INCH	IN/MM	4:1	INCH	☉ □
REV	DESCRIPTION	4 PLACES	± ---	± ---	DRAWN BY: SUDHIR	DATE: 2004/09/27	TITLE RMINAL, SOCKET 84/(2.13) DIA. SERIES
		3 PLACES	± ---	± .010	CHECKED BY: KPRASAD	DATE: 2004/09/27	
		2 PLACES	± 0.25	± .015	APPROVED BY: KPRASAD	DATE: 2004/09/27	MATERIAL NO. DOCUMENT NO. SHEET NO. SEE CHART SD-42024-**** 1 OF 2
		1 PLACE	± 0.38	± ---	ANGULAR ±1/2°		
DRAFT WHERE APPLICABLE MUST REMAIN WITHIN DIMENSIONS		SIZE A2		THIS DRAWING CONTAINS INFORMATION THAT IS PROPRIETARY TO MOLEX INCORPORATED AND SHOULD NOT BE USED WITHOUT WRITTEN PERMISSION			

ENG. NO.	EDP NO.	FINISH (REF)	CONTACT AREA (REF)	CRIMP AREA (REF)	MATERIAL (REF)	WIRE SIZE	INSULATION DIA.
42024-IA1	002-08-1001	SDES-88-P901	----	----	C26000	#14-#20 AWG	.060-.130
42024-IA1L	002-08-1002	SDES-88-P901	----	----	C26000	#14-#20 AWG	.060-.130
42024-IB1	002-08-1003	SDES-88-P901	----	----	C51000	#14-#20 AWG	.060-.130
42024-IB1L	002-08-1004	SDES-88-P901	----	----	C51000	#14-#20 AWG	.060-.130
42024-IA2	002-08-1005	SEE NOTE 5	.000030 MIN GOLD	.000100 MIN MATTE TIN	C26000	#14-#20 AWG	.060-.130
42024-IA2L	002-08-1006	SEE NOTE 5	.000030 MIN GOLD	.000100 MIN MATTE TIN	C26000	#14-#20 AWG	.060-.130
42024-IB2	002-08-1007	SEE NOTE 5	.000030 MIN GOLD	.000100 MIN MATTE TIN	C51000	#14-#20 AWG	.060-.130
42024-IB2L	002-08-1008	SEE NOTE 5	.000030 MIN GOLD	.000100 MIN MATTE TIN	C51000	#14-#20 AWG	.060-.130

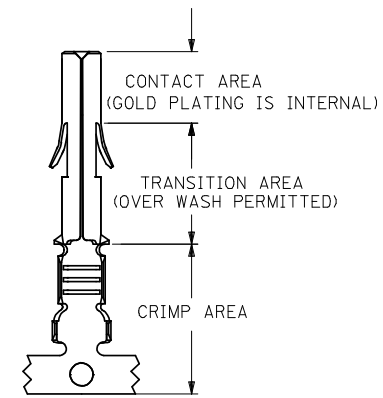

### PLATING REGIONS

APPLIES TO GOLD PLATED TERMINALS ONLY

#### NOTES:

- SOCKET TERMINALS FOR USE WITH THE .084/(2.13) SERIES HOUSINGS:  
 PLUG (42021-\*\*)  
 CAP (42022-\*\*)
- SOCKET TERMINALS MATE WITH PIN TERMINALS: .084/(2.13) DIA. SERIES (42023-\*\*\*\*).
- TERMINALS FINISHED IN CHAIN UNLESS SPECIFIED LOOSE. 'L' SUFFIX INDICATES LOOSE FORM. (SEE TABLE)
- MATERIAL: .012/(0.30) THICK STRIP:  
 A = BRASS, \*C26000, PER SMES-124-C7.  
 B = PHOSPHOR BRONZE, \*C51000, PER SMES-124-E7.
- FINISH:  
 1 = HOT TIN DIP 20 m.l./(.51 MICRONS) MINIMUM (PER SDES-88-P901).  
 2 = 30 (M.I) / 0.75 MICRONS) MIN SELECT GOLD AND 100 (M.I) (2.50 MICRON) MIN SELECT TIN (MATTE) OVER 50 (M.I) (1.25 MICRONS) MIN NICKEL OVERALL
- CRIMP RANGE: SEE CHART.
- PRODUCT SPECIFICATION PS-42022-0001 APPLIES.

#### LEGEND:

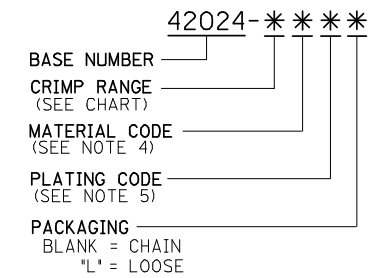

<b>ENTER DESCRIPTION</b> EC NO: 12008-0359 DRW: SUDHIR 2008/03/03 CHKD: VINU 2008/03/03 APPR: KPRASAD 2008/03/03 REV	<b>QUALITY SYMBOLS</b> ▽=0 ▽=0	<b>GENERAL TOLERANCES (UNLESS SPECIFIED)</b> <table border="1"> <tr> <th></th> <th>mm</th> <th>INCH</th> </tr> <tr> <td>4 PLACES</td> <td>±----</td> <td>±----</td> </tr> <tr> <td>3 PLACES</td> <td>±----</td> <td>±----</td> </tr> <tr> <td>2 PLACES</td> <td>±----</td> <td>±----</td> </tr> <tr> <td>1 PLACE</td> <td>±----</td> <td>±----</td> </tr> <tr> <td colspan="3">ANGULAR ±---°</td> </tr> </table>		mm	INCH	4 PLACES	±----	±----	3 PLACES	±----	±----	2 PLACES	±----	±----	1 PLACE	±----	±----	ANGULAR ±---°			<b>DIMENSION STYLE</b> IN/MM	<b>SCALE</b> ---	<b>DESIGN UNITS</b> INCH	THIRD ANGLE PROJECTION
		mm	INCH																					
	4 PLACES	±----	±----																					
	3 PLACES	±----	±----																					
2 PLACES	±----	±----																						
1 PLACE	±----	±----																						
ANGULAR ±---°																								
<b>DRAFT WHERE APPLICABLE MUST REMAIN WITHIN DIMENSIONS</b>		DRAWN BY: SUDHIR DATE: 2004/09/27	CHECKED BY: KPRASAD DATE: 2004/09/27	TITLE: RMINAL, SOCKET 84/(2.13) DIA. SERIES																				
MATERIAL NO. SEE CHART		APPROVED BY: KPRASAD DATE: 2004/09/27	MOLEX INCORPORATED																					
SIZE: A2 THIS DRAWING CONTAINS INFORMATION THAT IS PROPRIETARY TO MOLEX INCORPORATED AND SHOULD NOT BE USED WITHOUT WRITTEN PERMISSION		DOCUMENT NO. SD-42024-****		SHEET NO. 2 OF 2																				