

# FRDM-KW41Z Freedom Development Board

## User's Guide

## Contents

### 1. Introduction

This user's guide describes the hardware for the FRDM-KW41Z Freedom development board. The FRDM-KW41Z Freedom development board is a small, low-power, and cost-effective evaluation and development board for application prototyping and demonstration of the KW41Z/31Z/21Z (KW41Z) family of devices. These evaluation boards offer easy-to-use mass-storage-device mode flash programmer, a virtual serial port, and standard programming and run-control capabilities.

The KW41Z is an ultra-low-power, highly integrated single-chip device that enables Bluetooth Low Energy (BLE), Generic FSK (at 250, 500 and 1000 kbps) or IEEE Standard 802.15.4 with Thread support for portable, extremely low-power embedded systems.

The KW41Z integrates a radio transceiver operating in the 2.36 GHz to 2.48 GHz range supporting a range of FSK/GFSK and O-QPSK modulations, an ARM Cortex-M0+ CPU, up to 512 KB Flash and up to 128 KB SRAM, BLE Link Layer hardware, 802.15.4 packet processor hardware and peripherals optimized to meet the requirements of the target applications

1.	Introduction .....	1
2.	Overview and Description .....	2
2.1	Overview .....	2
2.2	Feature description .....	3
2.3	Serial and Debug Adapter.....	5
3.	Functional description .....	6
3.1	RF circuit.....	6
3.2	Clocks.....	6
3.3	Power management.....	7
3.4	Serial flash memory (SPI interface).....	10
3.5	Accelerometer and magnetometer combo sensor... 11	
3.6	Thermistor .....	12
3.7	User application LEDs.....	12
3.8	Buttons and electrodes.....	14
3.9	IR transmitter.....	14
4.	Headers and Jumpers .....	16
4.1	Arduino compatible I/O headers.....	16
4.2	Jumper Table .....	18
5.	References .....	19
6.	Revision history.....	19





## 2.2 Feature description

The FRDM-KW41Z development board is based on NXP Freedom development platform. It is the most diverse reference design containing the KW41Z device and all necessary I/O connections for use as a standalone board, or connected to an application. The FRDM-KW41Z can also be used as an Arduino compatible shield. The following figure shows the FRDM-KW41Z development board.



**Figure 2: FRDM-KW41Z Freedom development board.**

The FRDM KW41Z development board has these features:

- NXP's ultra-low-power KW41Z Wireless MCU supporting BLE, Generic FSK, and IEEE Std. 802.15.4 (Thread) platforms
- IEEE Std. 802.15.4, 2006-compliant transceiver supporting 250 kbps O-QPSK data in 5.0 MHz channels, and full spread-spectrum encoding and decoding
- Fully compliant Bluetooth v4.2 Low Energy (BLE)
- Reference design area with small-footprint, low-cost RF node:
  - Single-ended input/output port
  - Low count of external components
  - Programmable output power from -30 dBm to +3.5 dBm at the SMA connector, when using DCDC Bypass or Buck modes of operation
  - Receiver sensitivity is -100 dBm, typical (@1 % PER for 20-byte payload packet) for 802.15.4 applications, at the SMA connector
  - Receiver sensitivity is -95 dBm (for BLE applications).
- Integrated PCB inverted F-type antenna and SMA RF port (requires moving C7 to C8)
- Selectable power sources

- DC-DC converter with Buck, Boost, and Bypass operation modes
- 32 MHz reference oscillator
- 32 kHz reference oscillator
- 2.4 GHz frequency operation (ISM and MBAN)
- 4-Mbit (512 kB) external serial flash memory for Over-the-Air Programming (OTAP) support
- Integrated Open-Standard Serial and Debug Adapter (OpenSDA)
- Cortex 10-pin (0.05") SWD debug port for target MCU
- Cortex 10-pin (0.05") JTAG port for OpenSDA updates
- One RGB LED indicator
- One red LED indicator
- Two push-button switches
- Two TSI buttons (Touch Sensing Input electrodes)

The following figure shows the main board features and Input/Output headers for the FRDM-KW41Z board:



Figure 3: FRDM-KW41Z component placement.

## 2.3 Serial and Debug Adapter

The FRDM-KW41Z development board includes OpenSDA v2.2—a serial and debug adapter circuit that includes an open-source hardware design, an open-source bootloader, and debug interface software. It bridges serial and debug communications between a USB host and an embedded target processor as shown in Figure 4. The hardware circuit is based on a NXP Kinetis K20 family microcontroller (MCU) with 128 KB of embedded flash and an integrated USB controller. OpenSDAv2.2 comes preloaded with the DAPLink bootloader - an open-source mass storage device (MSD) bootloader and the Segger J-Link Interface firmware, which provides a MSD flash programming interface, a virtual serial port interface, and a J-Link debug interface. For more information on the OpenSDAv2.2 software, see [mbed.org](http://mbed.org), <https://github.com/mbedmicro/DAPLink>, and [www.nxp.com/opensda](http://www.nxp.com/opensda).

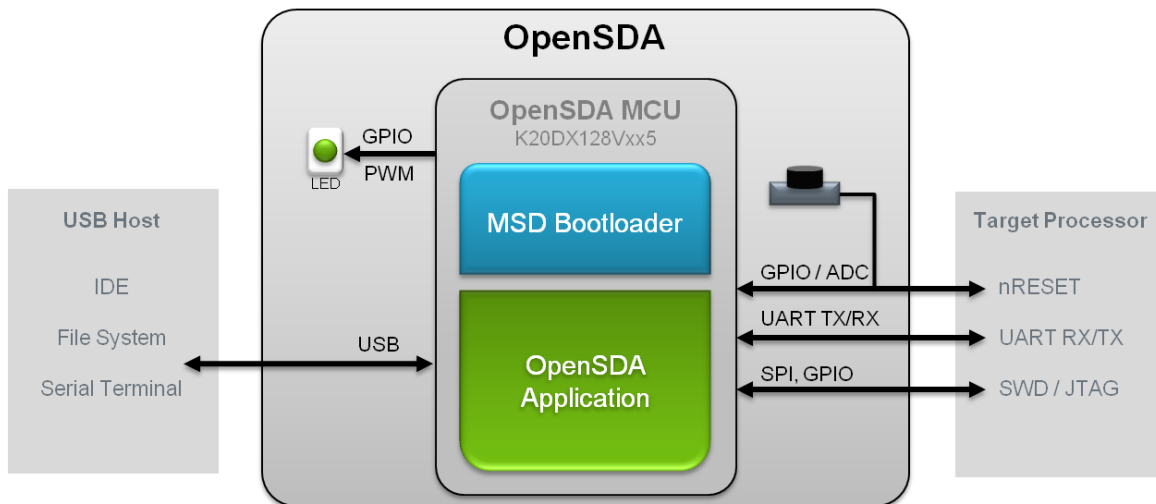

Figure 4: OpenSDAv3.0 high-level block diagram.

OpenSDAv2.2 is managed by a Kinetis K20 MCU built on the ARM Cortex-M4 core. The OpenSDAv2.2 circuit includes a status LED (D2) and a pushbutton (SW1). The pushbutton asserts the Reset signal to the KW41Z target MCU. It can also be used to place the OpenSDAv2.2 circuit into bootloader mode. UART and GPIO signals provide an interface to either the SWD debug port or the K20. The OpenSDAv2.2 circuit receives power when the USB connector, J6, is plugged into a USB host.

### 2.3.1 Virtual serial port

A serial port connection is available between the OpenSDAv2.2 MCU and pins PTC6 and PTC7 of the KW41Z.

#### NOTE

To enable the Virtual COM, Debug, and MSD features, Segger J-Link drivers must be installed. Download the drivers at <https://www.segger.com/downloads/jlink>.

### 3. Functional description

The four-layer board provides the KW41Z with its required RF circuitry, 32 MHz reference oscillator crystal, and power supply with a DC-DC converter including Bypass, Buck, and Boost modes. The layout for this base-level functionality can be used as a reference layout for your target board

#### 3.1 RF circuit

The FRDM-KW41Z RF circuit provides an RF interface for users to begin application development. A minimum matching network to the MCU antenna pin is provided through C4 and L1. An additional matching component, L7, is provided to match the printed F-antenna to 50 ohm controlled line.

An optional SMA is located at J5. This is enabled by rotating the 10 pF capacitor in C8 to the location of C7. The following figure shows the RF circuit in detail.

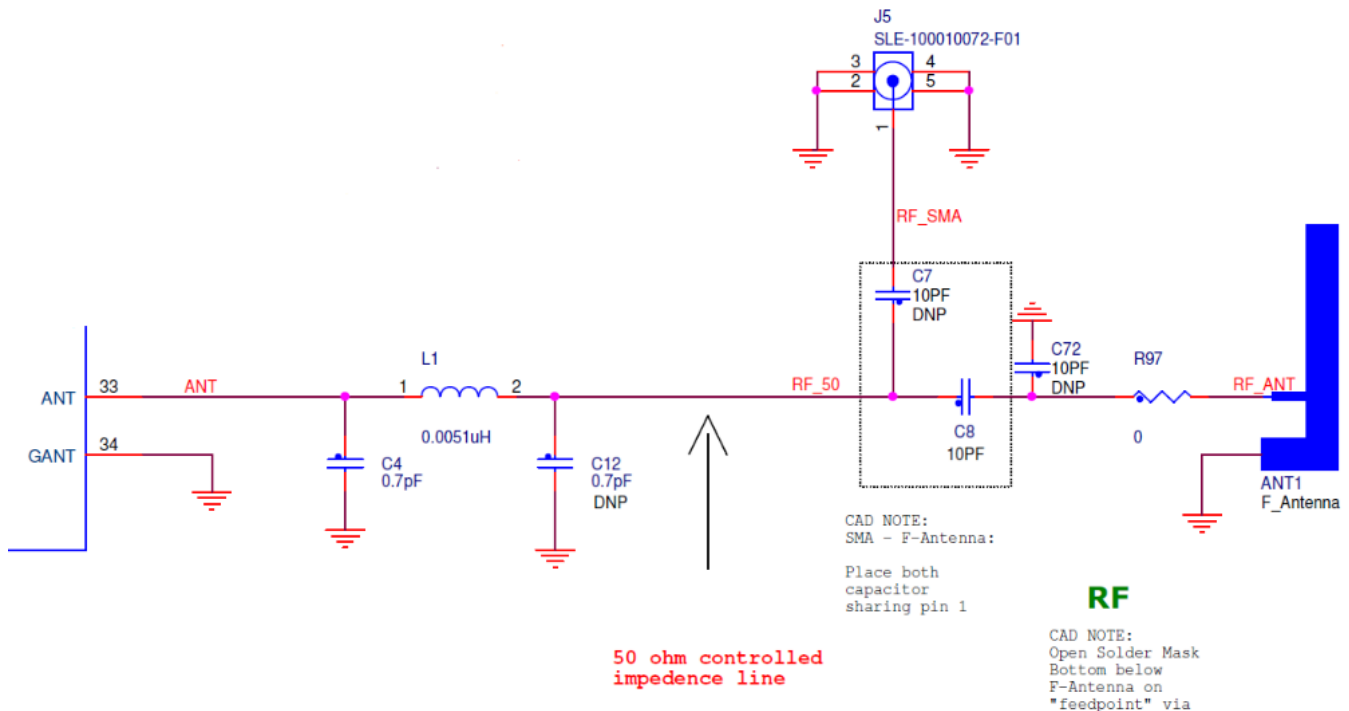

Figure 5: FRDM-KW41Z RF circuit.

#### 3.2 Clocks

The FRDM-KW41Z board provides two clocks. A 32 MHz clock for clocking MCU and Radio, and a 32.768 kHz clock to provide an accurate low power time base:

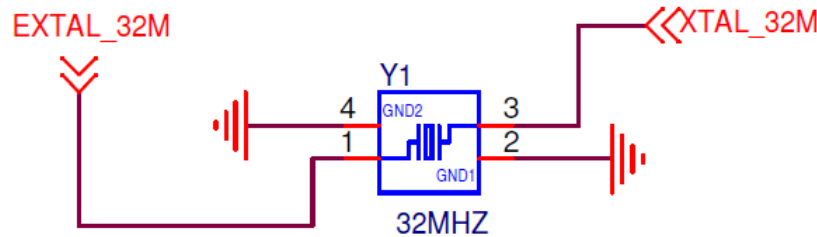

Figure 6: FRDM-KW41Z 32 MHz reference oscillator circuit.

- 32 MHz Reference Oscillator
  - Figure 6 shows the 32 MHz external crystal Y1. The IEEE Std. 802.15.4 requires the frequency to be accurate to less than  $\pm 40$  ppm
  - Internal load capacitors provide the bulk of the crystal load capacitance.
  - To measure the 32 MHz oscillator frequency, program the CLKOUT (PTB0) signal to provide buffered output clock signal

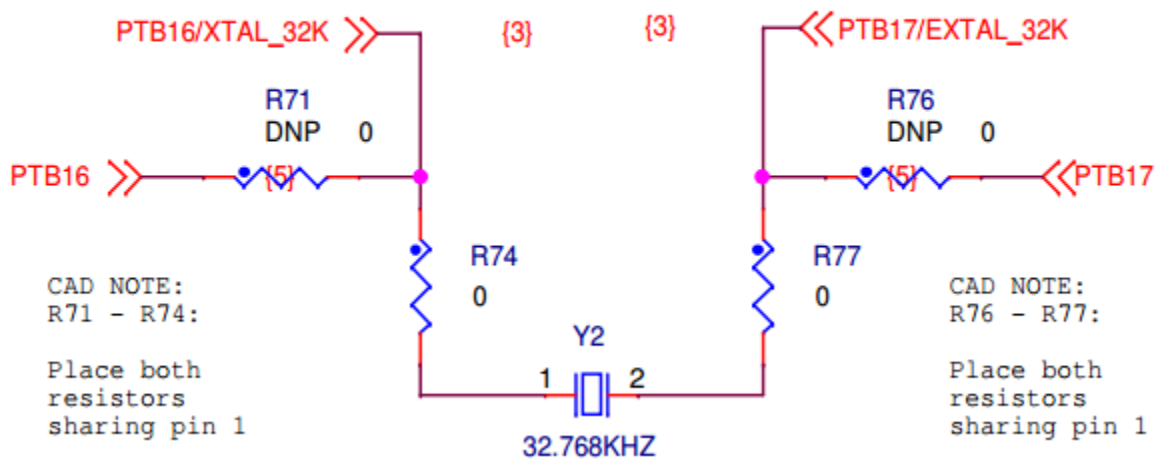

Figure 7: FRDM-KW41Z 32.786 kHz oscillator circuit.

- 32.768 kHz Crystal Oscillator (for accurate low-power time base)
  - A secondary 32.768 kHz crystal Y2 is provided (see Figure 9)
  - Internal load capacitors provide the entire crystal load capacitance
  - Zero ohm resistors are supplied to bypass the Y2 crystal
    - This provides two extra GPIO to the I/O headers; PTB16 & PTB17

### 3.3 Power management

There are several different ways to power and measure current on the FRDM-KW41Z board. The FRDM-KW41Z power-management circuit is shown in the following figure:

## Functional description

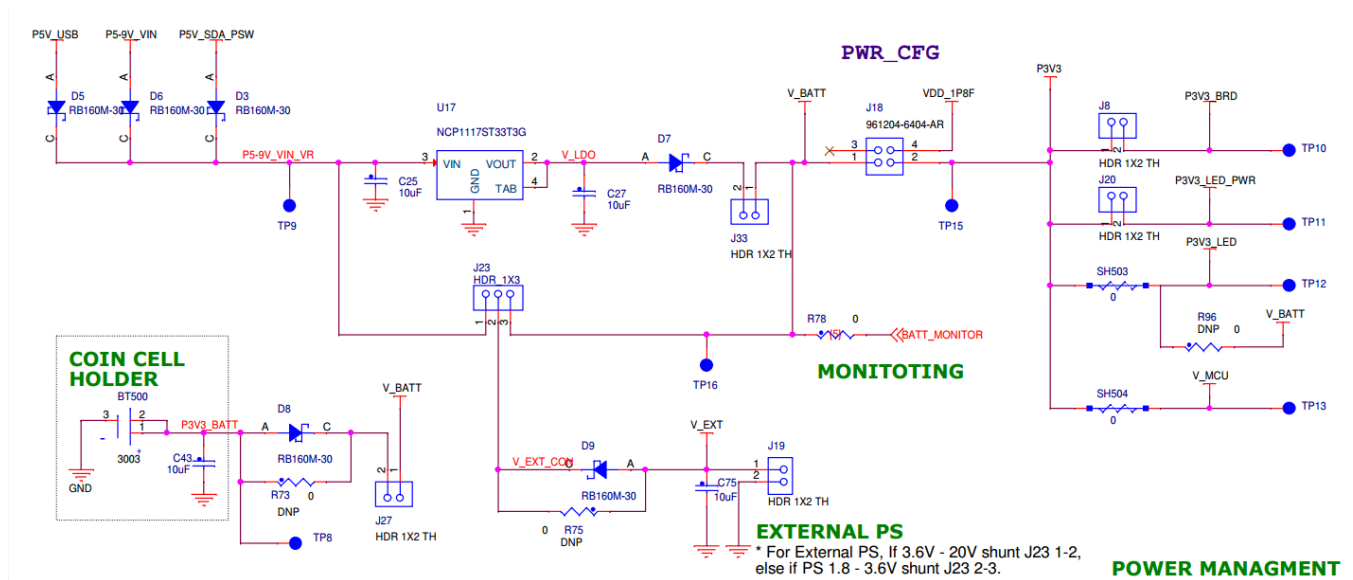

The FRDM-KW41Z can be powered by the following means:

- Through the micro USB type B connector (J6), which provides 5V to the P5V\_USB signal into the 3V3 LDO (U17)
- Through the Freedom development board headers, which provide either P3.3V or P5-9V\_VIN on header J3 pin-8 to LDO 3V3 (U17)
- From an external battery (Coin-cell – BT500)
- From an external DC supply in the following ways:
  - Connect an adapter that can supply 1.8 to 3.6 VDC to J19 pins using the selector J23 pin 2-3
  - Connect an unregulated external supply (of up to 5.5 VDC) to J19 pin 1 and the GND pin to use the on board 3.3 V LDO regulator (using the selector J23 pin 1-2)

The 2-pin 1×2 headers J8 and J20 can supply current to various board components and can be used to measure the current (if desired). Green LED marked as LED2 is available as a power indicator.

Power headers can supply either the LED, MCU, or peripheral circuits. Measure the current by inserting a current meter in place of a designated jumper. See Table 4 in section 4.2 for details on jumper descriptions.

The FRDM-KW41Z can be configured to use any of the DCDC converter operating modes. These modes are Bypass, Buck (Manual-Start), Buck (Auto-Start), and Boost. Figure 9, Figure 10, Figure 11, Figure 12, and Table 1 highlight the jumper settings for each of these modes.



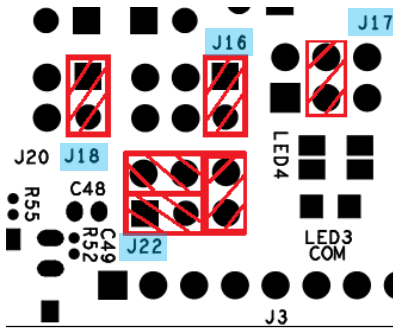

Figure 9: Jumper settings for Bypass mode.

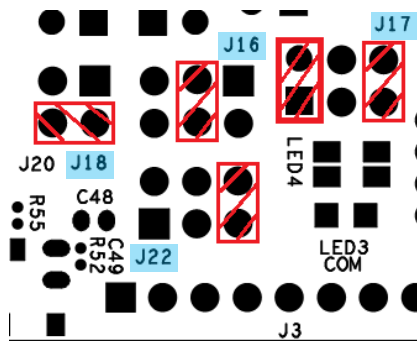

Figure 10: Jumper settings for Boost mode.

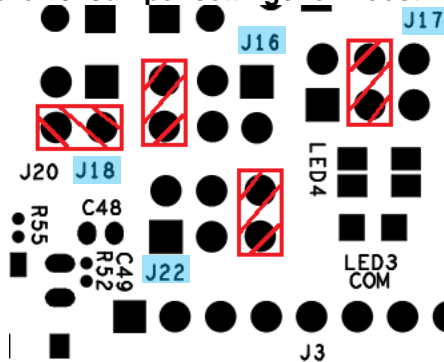

Figure 11: Jumper settings for Buck mode (Manual-start).

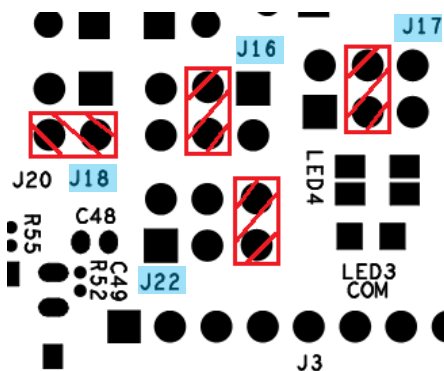

Figure 12: Jumper settings for Buck mode (Auto-start).

Table 1: DCDC configurations.

Mode	J18	J16	J17	J22
<b>Bypass Mode</b>	1-2	1-2	3-4	1-3 2-4 5-6
<b>Boost Mode</b>	2-4	3-4	1-2 5-6	5-6
<b>Buck Mode (manual start)</b>	2-4	5-6	3-4	5-6
<b>Buck Mode (auto start)</b>	2-4	3-4	3-4	5-6

### 3.4 Serial flash memory (SPI interface)

Component U4 is the AT45DB041E 4-Mbit (512 KB) serial flash memory with SPI interface. It is intended for Over-the-Air Programming (OTAP) or for storing the non-volatile system data, or parameters.

The figure below shows the memory circuit:

- Memory power supply is P3V3\_BRD
- Discrete pull-up resistors pads for SPI port
- You can share the SPI with other peripherals using the J1 I/O header
- The SPI Write Protect and Reset have a discrete pull-up resistor

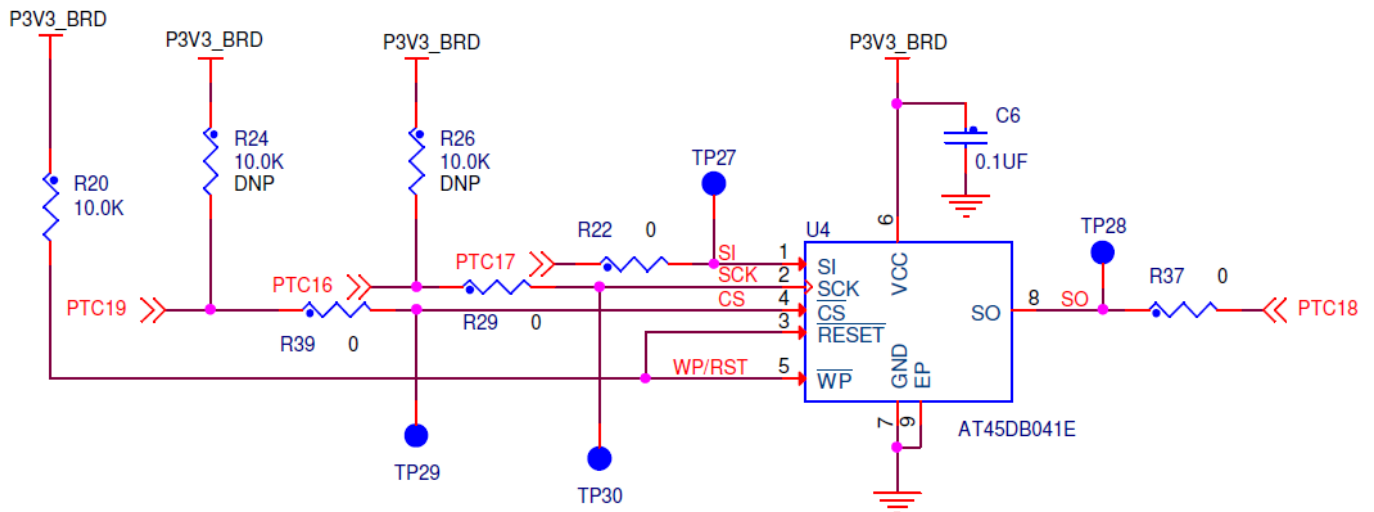

Figure 13: AT45DB041E 4-Mbit (512 KB) serial flash memory circuit.



### 3.6 Thermistor

One thermistor (RT2) is connected to two ADC inputs (ADC0\_DP0 & ADC\_DM0) of KW41Z for evaluating the ADC module.

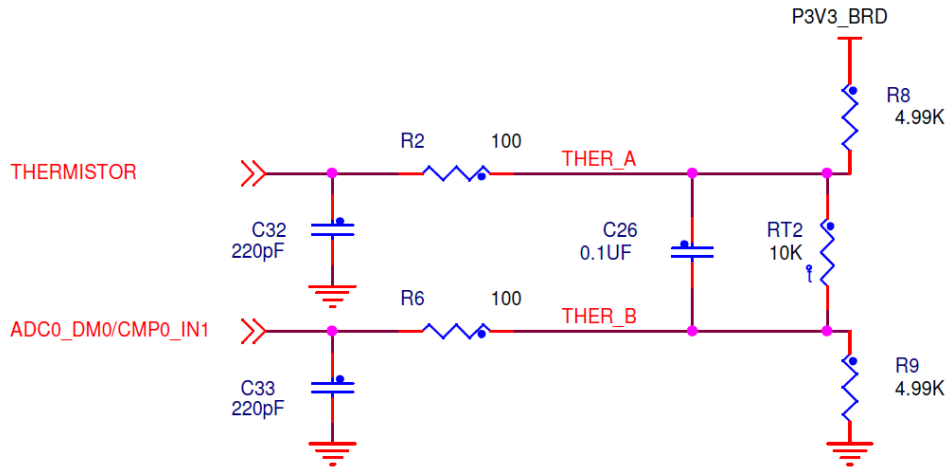

Figure 15: Thermistor circuit.

The high side of the Thermistor circuit is attached to ADC0\_DP0 through J35. See the following figure for details.



Figure 16: ADC0\_DP0 selection jumper.

### 3.7 User application LEDs

The FRDM-KW41Z provides a RGB LED and a single red LED for user applications Figure 17 and Figure 18 show the circuitry for the application controlled LEDs.

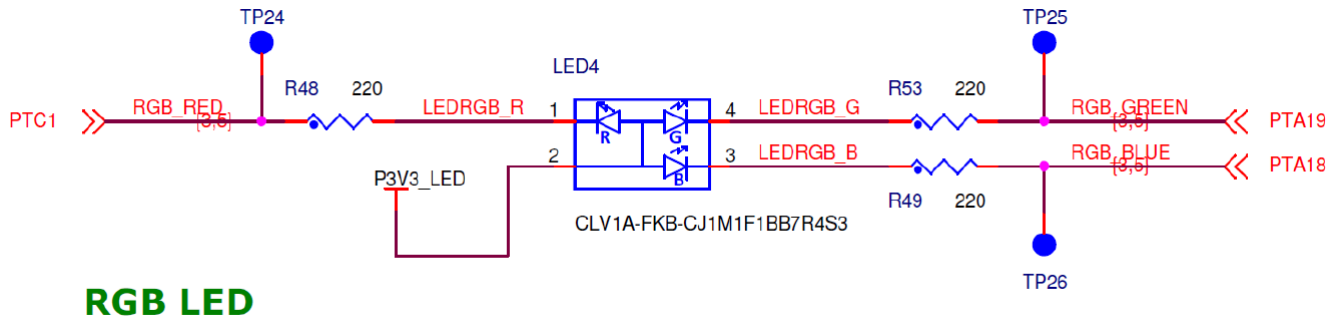

**RGB LED**

**Figure 17. FRDM-KW41Z RGB LED circuit**

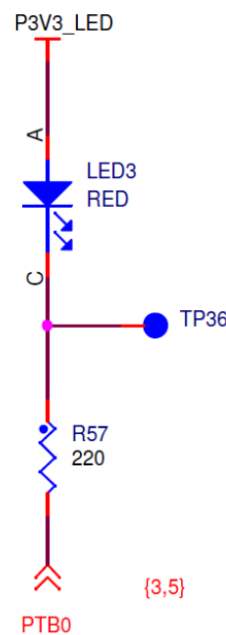

**Figure 18. FRDM-KW41Z LED3 circuit**

**NOTE**

When operating in default Buck and Boost configurations, the P3V3\_LED supply will be at 1.8V. The Blue and Green LED in the RGB LED will not illuminate at these voltages. To see these LEDs illuminate in Buck and Boost modes, the application software must increase the output voltage of the DCDC to 3V.

### 3.8 Buttons and electrodes

Two tactile buttons and two TSI electrodes are populated on the FRDM-KW41Z for Human Machine Interaction (HMI). The following figure shows the circuit for both the TSI electrodes and the tactile buttons.

ELECTRODES

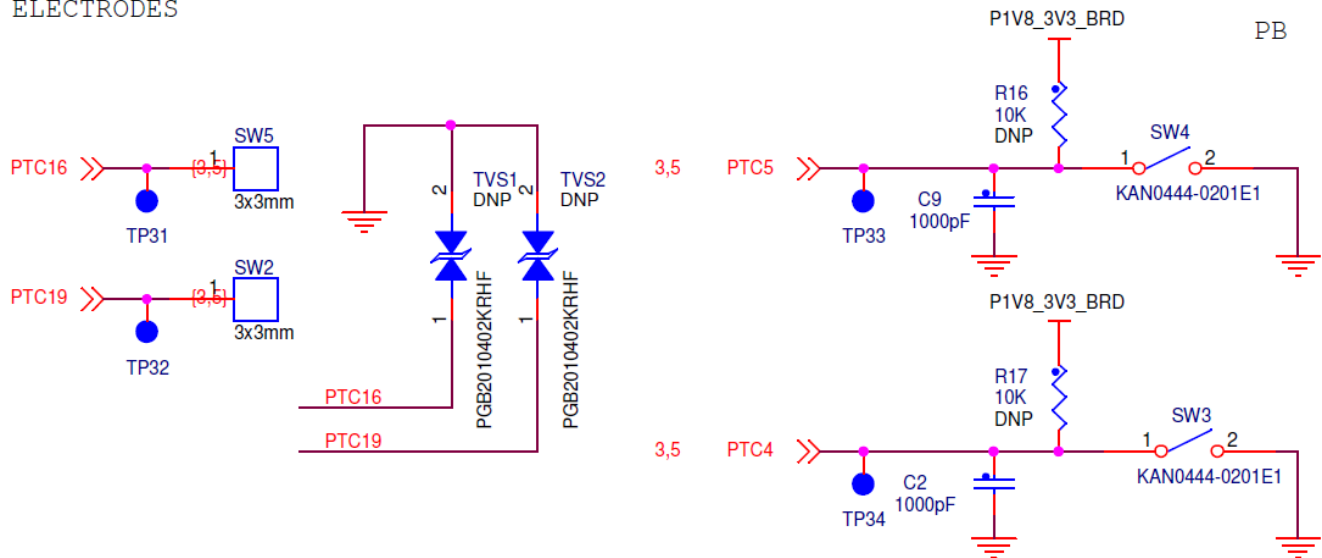

Figure 19.FRDM-KW41Z HMI circuit

### 3.9 IR transmitter

An optional infrared transmitter or blaster is provided to communicate over infra-red via the CMT module on KW41Z.

Figure 19 shows the IR circuit.

- The IR power supply is P3V3\_LED
- The IR has a range of approximately 10 meters
- The current draw is approximately 100 mA when active

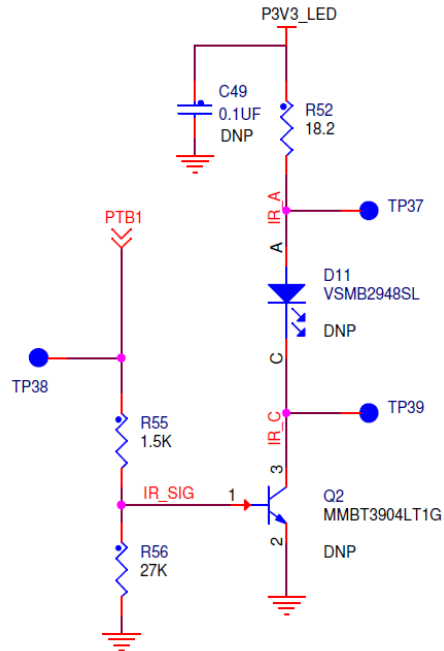

Figure 20. IR transmitter circuit.

#### NOTE

Components D11 and Q2 are not populated by default. These must be populated for the IR transmitter circuit to function.

## 4. Headers and Jumpers

### 4.1 Arduino compatible I/O headers

The following figure shows the I/O pinout.

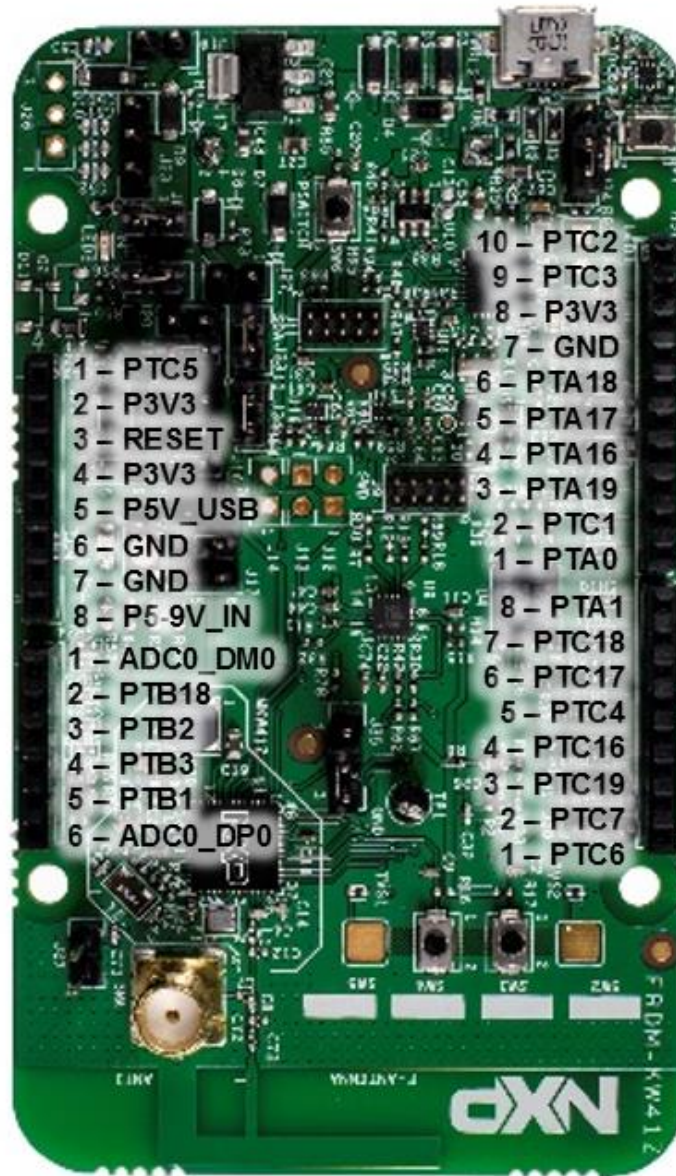

Figure 21: FRDM-KW41Z I/O header pinout



The following table shows the signals that can be multiplexed to each pin:

**Table 2: Arduino compatible header/connector pinout (J1 and J2)**

HDR Pin	1x10 Connector (J2) - Description	IC Pin
1	PTA0/TSI0_CH8/SPI0_PCS1/TPM1_CH0/DTEST12/SWD_DIO	1
2	PTC1/ANT_B/I2C0_SDA/UART0_RTS_b/TPM0_CH2/DTEST5/RF_ACTIVE	37
3	PTA19/TSI0_CH13/ADC0_SE5/LLWU_P7/SPI1_PSC0/TMP2_CH1/DTEST7/dcdc_testo5	7
4	PTA16/TSI0_CH10/LLWU_P4/SPI1_SOUT/TPM0_CH0/DTEST4/dcdc_testo2	4
5	PTA17/TSI0_CH11/LLWU_P5/RF_RESET/SPI1_SIN/TPM_CLKIN1/DTEST5/dcdc_testo3	5
6	PTA18/TSI0_CH12/LLWU_P6/SPI1_SCK/TPM_CH0/DTEST6/dcdc_testo4	6
7	GND	
8	VREFH/VREF_OUT	27
9	PTC3/TSI0_CH15/DIAG2/LLWU_P11/RX_SWITCH/I2C1_SDA/UART0_TX/TPM0_CH1/DTEST7/DTM_TX	39
10	PTC2/TSI0_CH14/DIAG1/LLWU_P10/TX_SWITCH/I2C1_SCL/UART0_RX/CMT_IRO/DTEST6/DTM_RX	38
HDR Pin	1x8 Connector (J1) - Description	IC Pin
1	PTC6/TSI0_CH2/LLWU_14/XTAL_OUT_EN/I2C1_SCL/UART0_RX/TPM2_CH0/DTEST2/BSM_FRAME	42
2	PTC7/TSI0_CH3/LLWU_P15/SPI0_PCS2/I2C1_SDA/UART0_TX/TPM2_CH1/DTEST3/BSM_DATA	43
3	PTC19/TSI0_CH7/LLWU_P3/SPI0_PCS0/I2C0_SCL/UART0_CTS_b/BSM_CLK/DTEST3/RF_ACTIVE	48
4	PTC16/TSI0_CH4/LLWU_P0/SPI0_SCK/I2C0_SDA/UART0_RTS_b/TPM0_CH3/DTEST0/dcdc_testo1	45
5	PTC4/TSI0_CH0/DIAG3/LLWU_P12/ANT_A/EXTRG_IN/UART0_CTS_b/TPM1_CH0/DTEST0/BSM_DATA	40
6A	PTC17/TSI0_CH5/LLWU_P1/SPI0_SOUT/I2C1_SCL/UART0_RX/BSM_FRAME/DTEST1/DTM_RX	46
6B	PTB16/EXTAL32K/I2C1_SCL/TPM2_CH0/DTEST10	21
7A	PTC18/TSI0_CH6/LLWU_P2/SPI0_IN/I2C1_SDA/UART0_TX/BSM_DATA/DTEST2/DTM_TX	47
7B	PTB17/XTAL32K/I2C1_SDA/TPM2_CH1/DTEST11/BSM_CLK	22
8	PTA1/TSI0_CH9/SPI1_PSC0/TPM1_CH1/DTEST13/SWD_CLK	2

**Table 3: Arduino compatible header/connector pinout (J3 and J4)**

HDR Pin	1x8 Connector (J3) - Description	IC Pin
1	PTC5/TSI0_CH1/DIAG4/LLWU_P13/RF_OFF/LPTMR0_ALT2/UART0_RTS_b/TPM1_CH1/DTEST1/BSM_CLK	41
2	IOREF(3V3)	-
3	PTA2/TPM0_CH3/RESET_b	3
4	3V3	-
5	5V	-
6	GND	-
7	GND	-
8	5-9V IN	-
HDR Pin	1x6 Connector (J4) - Description	IC Pin
1	ADC0_DM0/CMP0_IN1	25
2	DAC0_OUT/ADC0_SE4/CMP0_IN2	23
3	ADC0_SE3/CMP0_IN3	18
4	ADC0_SE2/CMP0_IN4	19
5	ADC0_SE1/CMP0_IN5	17
6A	ADC0_DP0/CMP0_IN0	24
6B	PTB0/LLWU_P8/XTAL_OUT_EN/I2C0_SCL/CMP0_OUT/TPM0_CH1/DTEST11/CLKOUT	16

## 4.2 Jumper Table

The jumper settings on the FRDM-KW41Z are described in the following table. \* denote jumper selection is shorted on board by default. Bold text indicates default selection.

**Table 4: FRDM-KW41Z jumper table**

Jumper	Option	Setting	Description
J8	P3V3_BRD	1-2	Isolate board supply to board peripherals
J12	SWD_CLK_TGTMCU	1-2*	Isolate SWD_CLK from SWD header
J13	SWD_DIO	1-2*	OpenSDA SWD_DIO isolation jumper
J14	SWD_CLK	1-2*	OpenSDA SWD_CLK isolation jumper
J16	PSW_CFG	1-2 3-4 5-6	<b>PSWITCH to ground</b> PSWITCH to VDCDC_IN PSWITCH to SW6
J17	DCDC_CFG	3-4 1-2; 5-6	<b>DCDC_CFG to VDCDC_IN</b> DCDC_CFG to ground; DCDC_LP to VDCDC__IN
J18	PWR_CFG	1-2 2-4	<b>V_BATT to P3V3</b> VDD_1P8F to P3V3
J20	P3V3_LED_PWR	1-2	<b>Isolate board power LED supply</b>
J22	REG_CFG	1-3; 2-4; 5-6 5-6	<b>V_MCU to VDD_1P8F; V_MCU to 1.5V; DCDC VDD_1P8 to VDD_1P8F</b> VDD_1P8 to VDD_1P8F
J23	V_EXT_CON	1-2 2-3	Connect external supply to VIN of U17 (regulator) Connect external supply to V_BATT
J24	RST Button Bypass	1-2 2-3	Reset button connected to OpenSDA Reset button connected to Target MCU
J25	SDA_RST_TGTMCU	1-2*	Isolate OpenSDA MCU from target MCU reset signal
J27	V_BATT	1-2	Isolate battery from V_BATT
J28/J29	SPI IN/OUT	<b>J28-1 J28-22 / J29-1 J29-2</b> J28-1 J29-2 / J28-2 J29-1	<b>SOUT to J2-4 / SIN to J2-5</b> SOUT to J2-5 / SIN to J2-4
J30/J31	UART RX/TX	<b>J30-1 J30-2 / J31-1 J31-2</b> J30-1 J31-2 / J30-2 J31-1	<b>RX to J1-1 / TX to J1-2</b> RX to J1-2 / TX to J1-1
J33	V_LDO	1-2	<b>Isolate V_BATT from 3.3V regulator (V_LDO)</b>
J34	V_BATT_VDCDC_IN	1-2	<b>Isolate VDCDC_IN from V_BATT</b>
J35	ADC SELECTOR	2-3 1-2	<b>ADC0_DP0 to THERMISTOR</b> ACD0_DP0 to BATT_MONITOR

## 5. References

The following references are available on [www.nxp.com/FRDM-KW41Z](http://www.nxp.com/FRDM-KW41Z):

- FRDM-KW41Z Design Package

## 6. Revision history

**Table 5. Revision history**

<b>Rev.</b>	<b>Date</b>	<b>Substantive change(s)</b>
0	10/2016	Initial release
1	08/2018	Updated OpenSDA chapter; Corrected Figure 5; Added operation note for FXOS8700 sensor.



**How to Reach Us:**

**Home Page:**  
[nxp.com](http://nxp.com)

**Web Support:**  
[nxp.com/support](http://nxp.com/support)

Information in this document is provided solely to enable system and software implementers to use NXP products. There are no express or implied copyright licenses granted hereunder to design or fabricate any integrated circuits based on the information in this document. NXP reserves the right to make changes without further notice to any products herein.

NXP makes no warranty, representation, or guarantee regarding the suitability of its products for any particular purpose, nor does NXP assume any liability arising out of the application or use of any product or circuit, and specifically disclaims any and all liability, including without limitation consequential or incidental damages. "Typical" parameters that may be provided in NXP data sheets and/or specifications can and do vary in different applications, and actual performance may vary over time. All operating parameters, including "typicals," must be validated for each customer application by customer's technical experts. NXP does not convey any license under its patent rights nor the rights of others. NXP sells products pursuant to standard terms and conditions of sale, which can be found at the following address:

[nxp.com/SalesTermsandConditions](http://nxp.com/SalesTermsandConditions).

While NXP has implemented advanced security features, all products may be subject to unidentified vulnerabilities. Customers are responsible for the design and operation of their applications and products to reduce the effect of these vulnerabilities on customer's applications and products, and NXP accepts no liability for any vulnerability that is discovered. Customers should implement appropriate design and operating safeguards to minimize the risks associated with their applications and products.

NXP, the NXP logo, NXP SECURE CONNECTIONS FOR A SMARTER WORLD, COOLFLUX, EMBRACE, GREENCHIP, HITAG, I2C BUS, ICODE, JCOP, LIFE VIBES, MIFARE, MIFARE CLASSIC, MIFARE DESFire, MIFARE PLUS, MIFARE FLEX, MANTIS, MIFARE ULTRALIGHT, MIFARE4MOBILE, MIGLO, NTAG, ROADLINK, SMARTLX, SMARTMX, STARPLUG, TOPFET, TRENCHMOS, UCODE, Freescale, the Freescale logo, Altivec, C 5, CodeTEST, CodeWarrior, ColdFire, ColdFire+, C Ware, the Energy Efficient Solutions logo, Kinetis, Layerscape, MagniV, mobileGT, PEG, PowerQUICC, Processor Expert, QorIQ, QorIQ Converge, Ready Play, SafeAssure, the SafeAssure logo, StarCore, Symphony, VortiQa, Vybrid, Airfast, BeeKit, BeeStack, CoreNet, Flexis, MXC, Platform in a Package, QUICC Engine, SMARTMOS, Tower, TurboLink, and UMEMS are trademarks of NXP B.V. All other product or service names are the property of their respective owners., Cortex, Jazelle, Keil, SecurCore, Thumb, TrustZone, and µVision are registered trademarks of Arm Limited (or its subsidiaries) in the EU and/or elsewhere. Arm7, Arm9, Arm11, big.LITTLE, CoreLink, CoreSight, DesignStart, Mali, Mbed, NEON, POP, Sensinode, Socrates, ULINK and Versatile are trademarks of Arm Limited (or its subsidiaries) in the EU and/or elsewhere. All rights reserved. Oracle and Java are registered trademarks of Oracle and/or its affiliates. The Power Architecture and Power.org word marks and the Power and Power.org logos and related marks are trademarks and service marks licensed by Power.org.

© 2016- 2018 NXP B.V.

Document Number: FRDMKW41ZUG  
Rev. 1  
08/2018

